



USER'S MANUAL
Part 2

DRAFT
2/25/02

2.4 GHz Corded Cordless Telephone with Caller ID/Call Waiting 1480



For Customer Service Or Product
Information, Visit Our Website At
www.telephones.att.com

Please also read
**Part 1 — Important
Product Information**

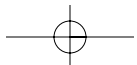
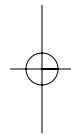
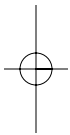

CONTENTS

BEFORE YOU BEGIN	1	CALLER ID OPERATION	17
About the Base and the Charger	1	About Call History	17
Choosing the Best Location	1	Review Call History	17
About Caller ID with Call Waiting	1	Delete Records from	
About Call History	2	Call History	18
INSTALLATION.	3	Dial a Displayed Number	18
Base Installation	3	Store a Call History Record	
Handset Charger Installation	7	in the Directory	19
Belt Clip	9	Display Screen Messages	19
Headset	9	Turn Off the Base	
TELEPHONE OPERATION		NEW CALL Indicator	19
AT THE BASE	10	ANSWERING SYSTEM OPERATION	
Make, Answer, or End a Call	10	AT THE BASE	20
Hold	10	Audible Indicators	20
Redial	10	Set the Clock	20
Flash	10	About Mailboxes	20
Speaker Volume.	10	About Announcements	20
Page/Intercom	10	Record Your Announcement	21
Base Ringer Volume Switch	10	Answering System Feature Setup	22
TELEPHONE OPERATION		Feature Summary	22
AT THE HANDSET	11	Listen to, Save & Delete Messages	23
Answer a Call	11	Play Messages.	23
Make a Call	11	Delete Messages	23
End a Call	11	Adjust Playback Volume.	23
Hold	11	Call Screening/Intercept	24
Redial	11	Record a Memo	24
Flash/Call Waiting	11	Message Window Display	24
Page/Intercom	11	ANSWERING SYSTEM OPERATION	
Change Channel	11	AT TOUCH TONE PHONE	25
Handset Volume	11	Connect with the	
Handset Ringer		Answering System	25
Style/Battery Save	12	Voice Menu.	25
Temporary Tone Dialing		Remote Access Commands	25
(Base or Handset)	12	BATTERIES	27
Headset	12	Charge the Handset Battery Pack	27
Operating Range	13	Replacing the Handset	
Display Screen Messages		Battery Pack	28
(Handset and Base)	13	IN CASE OF DIFFICULTY	29
TELEPHONE MEMORY			
AT THE BASE OR HANDSET	14		
Store a Number /Name			
in the Directory	14		
Edit a Number/Name Stored			
in the Directory	15		
Delete a Number/Name Stored			
in the Directory	16		
Dial a Number from the Directory	16		

BEFORE YOU BEGIN

About the Base and the Charger

This product provides you with a base station with corded handset, a cordless handset, and a handset charger. You'll need to connect the base to both AC power and a modular telephone jack. You'll connect the handset charger to AC power only. For more information, please see INSTALLATION in this User's Manual.

Choosing the Best Location

Choose a location for the base near an electrical outlet and a telephone jack. This phone requires a modular telephone jack and a standard electrical outlet (110v AC) not controlled by a wall switch. For optimum performance, install the base on the highest floor of your home and away from other cordless telephones.

NOTE: 2.4 GHz Digital Spread Spectrum telephones may cause interference with this telephone.

About Caller ID with Call Waiting

This product has a Caller ID with Call Waiting feature that works with service from your local phone service provider.

Caller ID with Call Waiting lets you see who's calling before you answer the phone, even when you're on another call.

You may need to change your phone service to use this feature. Contact your phone service provider if:

- You have both Caller ID and Call Waiting, but as separate services (you may need combined service)
- You have only Caller ID service, or only Call Waiting service
- You don't subscribe to any Caller ID or Call Waiting services.

You can also use this product with regular Caller ID service, and you can use this product's other features without subscribing to either Caller ID or combined Caller ID with Call Waiting service. To turn off this phone's Caller ID with Call Waiting feature, see the FEATURE SETUP section of this manual.

There are fees for Caller ID services, and they may not be available in all areas.

This phone can provide information only if both you and the caller are in areas offering Caller ID service and if both telephone companies use compatible equipment.

BEFORE YOU BEGIN

About Call History

This phone assigns each incoming call a number from 1 to 90. The most recent call will have the lowest number. When the memory is full, the oldest call information is deleted to make room for new incoming call information.

If you answer a call before information appears on the screen, it may not be in the call history.

Call history information is stored independently at the base and at each handset. If you make changes to call records in one location, other history lists are not affected.

INSTALLATION

Base Installation Table/Desk

1 Connect the corded handset to the base

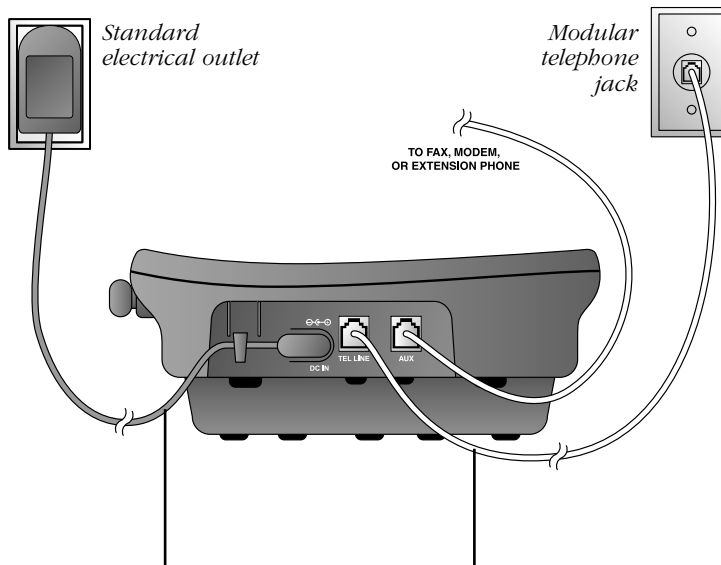

2 Connect the telephone line cord.

3 Connect the power cord.

The ANSWER ON/OFF light goes on, and **CL** flashes in the Message Window.

4 Check for dial tone.

Lift the handset; you should hear a dial tone.



Use only the power cord supplied with this product. If you need a replacement, call 1 800 222-3111.

INSTALLATION

Wall Mount

- 1 Remove the adapter from under the base as shown.

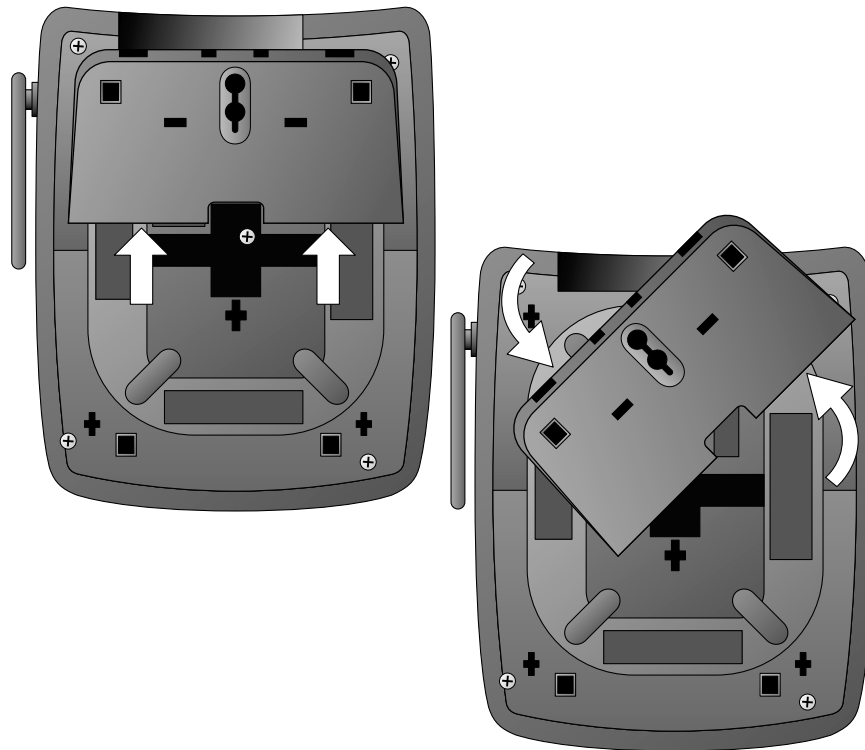

- 2 Reverse handset tab.

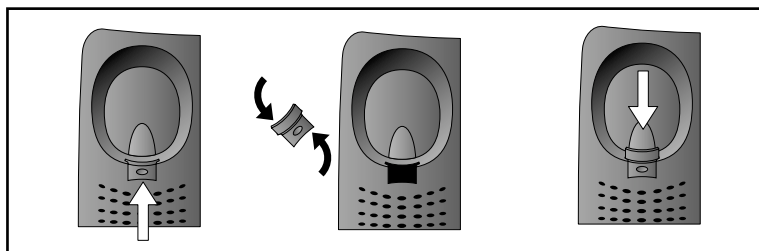

- 3 Connect the telephone line cord to the jack labeled TEL LINE on the back of the base.
- 4 Connect the power cord to the jack labeled DC IN on the back of the base.

4

INSTALLATION

- 5** Wrap the telephone line cord around the posts on the bottom of the base.

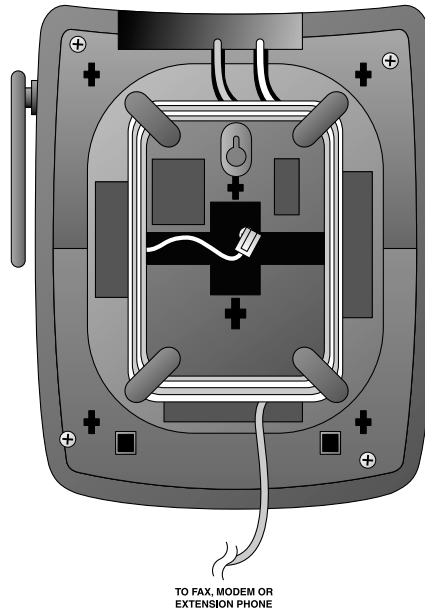

- 6** Replace the adapter on the base so the larger end is toward the bottom as shown.

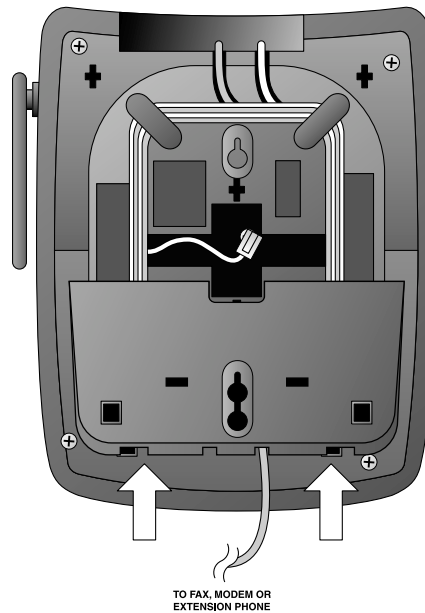

INSTALLATION

- 7 **Connect the corded handset to the base.**
- 8 **Connect the telephone line cord to the modular telephone jack.**
- 9 **Plug the power cord into the electrical outlet.**

The ANSWER ON/OFF light goes on, and **CL** flashes in the Message Window.

 Use only the power cord supplied with this product. If you need a replacement, call 1 800 222-3111.

- 10 **Mount the base on the wall.**

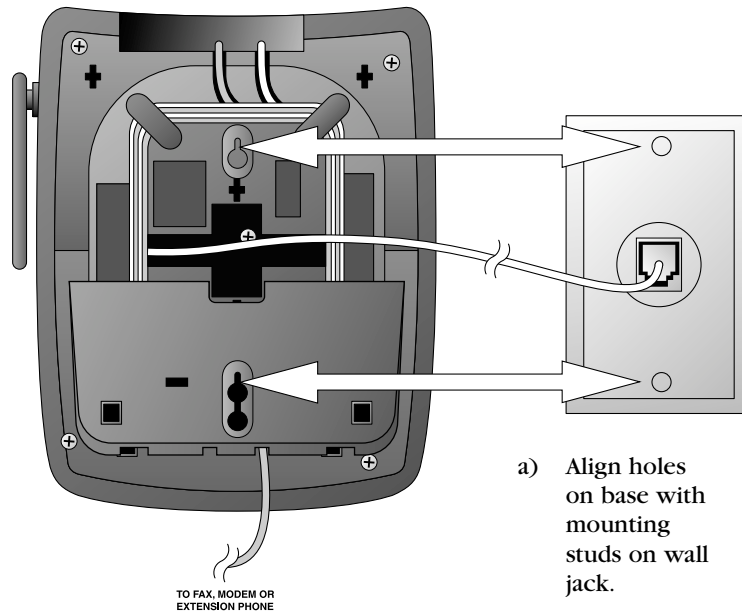

a) Align holes on base with mounting studs on wall jack.

b) Pull base down on mounting studs until it locks into place.

- 11 **Check for dial tone.**

Lift the handset; you should hear a dial tone.

INSTALLATION

Handset Charger Installation

- 1 Connect the power cord.** Feed the power cord through the strain-relief channel on the bottom of the handset charger. Then plug the cord into an electrical outlet not controlled by a wall switch.

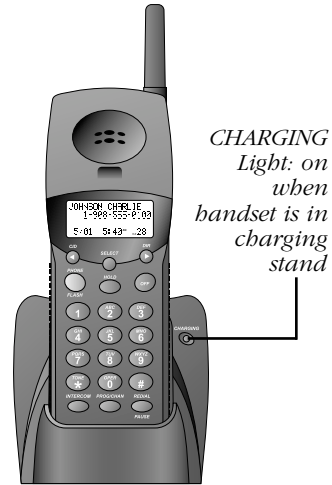

- 2 Install the handset battery.**

Use only AT&T Replacement Battery 3301, SKU# 91076.

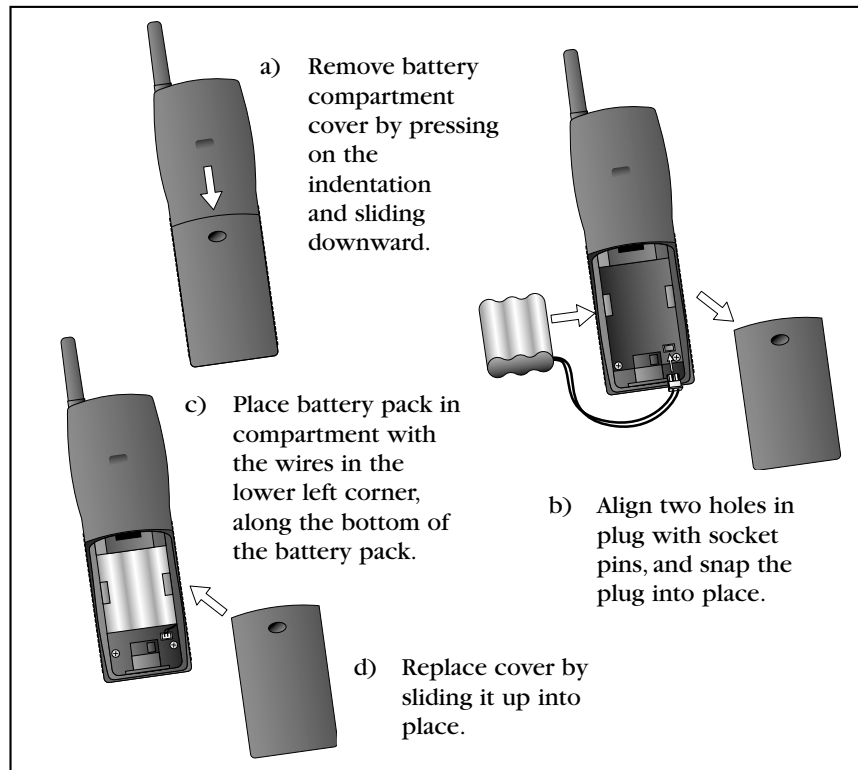

INSTALLATION

3 Charge the handset battery.

- Place the handset in the remote charging stand.
The CHARGING light goes on.
- Charge the battery at least 12 hours.

4 Check for dial tone.

- After the batteries are charged, lift the handset and press **[PHONE]**; you should hear a dial tone.

5 Set the time and date displayed on handset screen.

If you subscribe to Caller ID service, the date and time will be set automatically with the first incoming call.

If you do not have Caller ID service, you can set the date and time manually.

- Press **[PROG/CHAN]**, then press **[▶]** until DATE/TIME is displayed. Press **[SELECT]**.
- The month is flashing. Use **[◀]** and **[▶]** to select the current month. Press **[SELECT]**.
- The day is flashing. Use **[◀]** and **[▶]** to select the correct day. Press **[SELECT]**.
- The hour is flashing. Use **[◀]** and **[▶]** to select the current hour. Press **[SELECT]**.
- The minute is flashing. Use **[◀]** and **[▶]** to select the correct minute. Press **[SELECT]**.
- AM or PM is flashing. Use **[◀]** and **[▶]** to choose between AM and PM. Press **[SELECT]**.

6 Set the phone for tone or pulse dialing (base only).

- Press **[PROG]** on base.
- Press **[◀]** or **[▶]** until DIAL MODE:TONE is displayed.
- Use **[◀]** and **[▶]** to select the correct setting.
- Press **[SELECT]** to save the setting.

NOTE: Install the base unit and spare handset charger away from electronic equipment, such as personal computers, television sets or microwave ovens. Avoid excessive heat, cold, dust or moisture.

INSTALLATION

Belt Clip

Attach belt clip to the cordless handset (*optional*).

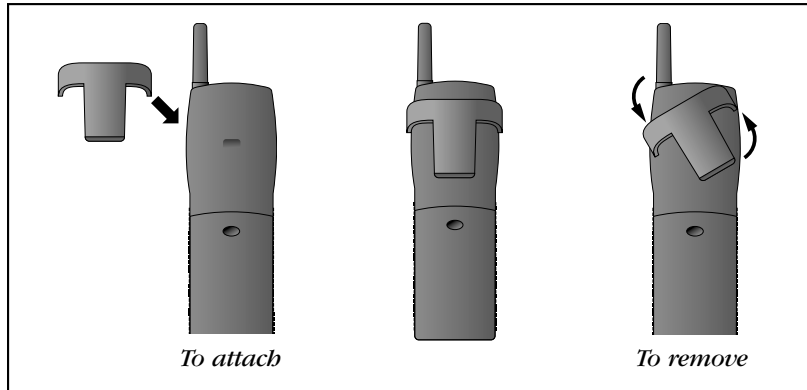

Headset

You can use this telephone with any industry standard 2.5 mm headset (purchased separately). For best results, use an AT&T 2.5 mm headset.

Plug the headset into the jack located on the left side of the handset (under the small rubber flap) or into the jack on the right side of the base. Do not force the connection, but make sure the plug fits securely.



TELEPHONE OPERATION AT THE BASE

Base Ringer Volume Switch

Use to adjust how loudly the base rings.

Display Dial

Press to dial the number currently displayed on screen.

Hold

Press **HOLD** to put a call on hold. The IN USE light flashes. To return to the call, press **SPEAKER**.

NOTE: When Hold is active, pressing **PHONE** on handset will also return you to the call.

Speaker Volume

While on a call, use to adjust the volume of what you hear.

Make, Answer, or End a Call

Press **SPEAKER**. When calling, use the base keypad to dial or enter a memory location. **SPEAKER** light is on when call is connected.

—OR—

1 Dial the number. Use **☑** to make corrections.

2 Press **DISPLAY DIAL** or **SPEAKER** to place the call.

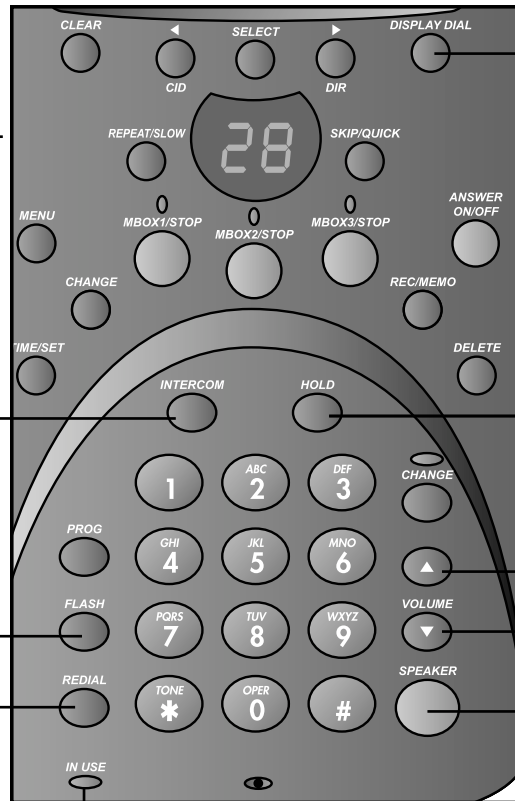

Redial

Press to call the last number dialed at the base (up to 32 digits).

*On steadily:
handset or base
speakerphone is in use*

*Flashing slowly:
a call is on hold*

Flash

Access subscriber services while on a call.

Page/Intercom

- 1** Press and release to signal someone at the handset. A paging tone sounds.
- 2** When the person at the handset presses **INTERCOM**, the handset and base can communicate without tying up the phone line.
- 3** Press again or press **OFF** on handset to disconnect.

TELEPHONE OPERATION AT THE HANDSET

Answer a Call

Press any key except **[OFF]**.

Make a Call

Press **[PHONE]**, then dial the number — **OR** — Dial the number (use **[◀]** to backspace and correct digits), then press **[PHONE]** to call.

Flash/ Call Waiting

Access special telephone company subscriber services.

Hold

Press to put a call on hold. Press again to release hold

— **OR** — Lift the handset of an extension.

Page/Intercom

- 1 Press and release to signal someone at the base. A paging tone sounds.
- 2 When the person at the base presses **[INTERCOM]**, the handset and base can communicate without tying up the phone.
- 3 Press **[OFF]** or press **[INTERCOM]** on base to disconnect.

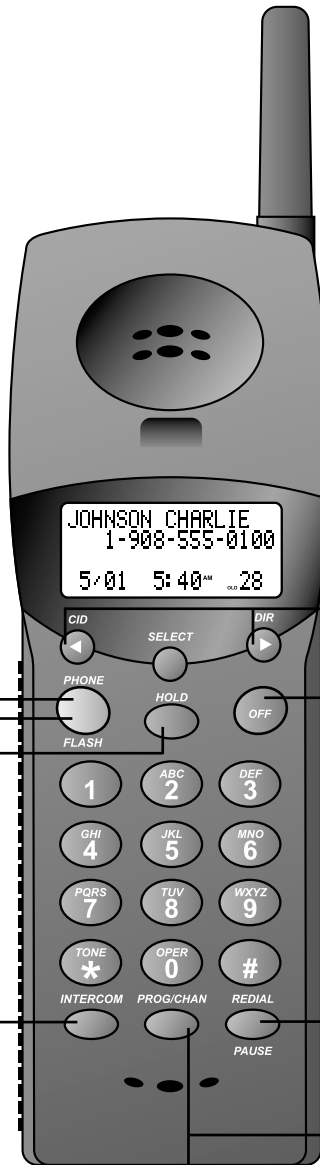

Handset Volume

While on a call, adjust volume of what you hear.

End a Call

Press **[OFF]** — **OR** — Place handset in handset charger.

Exit programming.

Cancel a page.

Redial

Press **[PHONE]**, then press **[REDIAL]** to call last number dialed (up to 32 digits).

Change Channel

Switch to a clearer channel while on a call.

Enter programming while not on a call.

TELEPHONE OPERATION AT THE HANDSET

Handset Ringer Style/Battery Save

You can select from four different handset ringer styles, or turn the ringer off and extend the battery life.

- 1 Make sure the handset is off.
- 2 Press **PROG/CHAN** to enter programming mode.
- 3 Press **▶** until the screen displays RINGER:.
- 4 Press **SELECT**. The screen displays the current setting.
- 5 Press **◀** or **▶** to select 1, 2, 3, 4, or OFF. You will hear a sample of each ring.
- 6 Press **SELECT** to choose the displayed ringer setting.

Temporary Tone Dialing (Base or Handset)

If you have dial pulse (rotary) service, you can change from dial pulse to touch tone dialing during a call by pressing **⊗**. This is useful if you need to send touch tone signals for access to telephone banking or long-distance services.

- 1 Dial the number.
- 2 Press **⊗**. Buttons pressed after this send touch tone signals.
- 3 After you hang up, the phone automatically returns to dial pulse (rotary) service.

Headset

You can use this telephone with any industry standard 2.5 mm headset (purchased separately). For best results, use an AT&T 2.5 mm headset.

Plug the headset into the jack located on the left side of the handset (under the small rubber flap) or into the jack on the right side of the base. Do not force the connection, but make sure the plug fits securely.



TELEPHONE OPERATION AT THE HANDSET

Operating Range

This cordless telephone operates within the maximum power allowed by the Federal Communications Commission (FCC). Even so, this handset and base can communicate over only a certain distance — which can vary with the locations of the base and handset, the weather, and the construction of your home or office. For best performance, keep the base antenna fully upright.

If you receive a call while you are out of range, the handset might not ring — or if it does ring, the call might not connect when you press **[PHONE]**. Move closer to the base, then press **[PHONE]** to answer the call.

If you move out of range during a phone conversation, you might hear noise or interference. To improve reception, move closer to the base.

If you move out of range without pressing **[OFF]**, your phone will be left “off the hook.” To hang up properly, walk back into range, periodically pressing **[OFF]**.

Display Screen Messages (Handset and Base)

Screen Displays:	When:
RINGING	There is a call coming in.
CONNECTING	The handset is waiting for a dial tone.
PHONE ON	The handset is in use.
PAGING	The base is paging the handset.
HOLD	There is a call on hold.
BATTERY LOW	The battery needs to be recharged.

TELEPHONE DIRECTORY

AT THE BASE OR HANDSET

The base and cordless handset can each store 50 telephone numbers with names, each up to 24 digits long. Directory information is stored independently at the base and cordless handset. Changes made to entries at one location do not affect the other directory. Entries are stored alphabetically. For consistency with Caller ID entries, you may wish to enter last names first.

Note: Press **OFF** at any time to exit directory.

Store a Number/Name in the Directory

- 1 Press **PROG** on the base or **PROG/CHAN** at the handset. The screen displays **DIRECTORY**.
- 2 Press **SELECT**. The screen displays **ENTER NAME**.
- 3 Using the chart below, enter up to 15 characters for the name you're storing with the number. Use **◀** to backspace and make corrections; use **▶** to advance and add a space.

Dial Key	Presses					
	1	2	3	4	5	6
1	1					
2	A	B	C	2		
3	D	E	F	3		
4	G	H	I	4		
5	J	K	L	5		
6	M	N	O	6		
7	P	Q	R	S	7	
8	T	U	V	8		
9	W	X	Y	Z	9	
0	0					
*	*					
#	&	'	,	-	.	#

TELEPHONE DIRECTORY

AT THE BASE OR HANDSET

- 4 When you finish entering the name, press **SELECT**.
The screen displays ENTER NUMBER.
- 5 Enter the telephone number. Use **◀** to backspace and make a correction. Press **REDIAL/PAUSE** to store a pause in the dialing sequence.
—OR—
Press **REDIAL/PAUSE** to display the last number dialed from this phone.
- 6 Press **SELECT**. If you are using the base, you are now done. If you are using the handset, the screen displays DISTINCT RING? and the current setting.
- 7 Press **◀** or **▶** to change the setting. Choose **Y** (for Yes) if you wish the phone to alert you to calls from this number by changing to a distinctive ringing pattern after the first ring. Choose **N** (for NO) for a normal ringing pattern.
- 8 Press **SELECT** to confirm your selection. If you chose **Y** in **Step 7**, a **▶** will be displayed with the directory entry.

Note: When memory is full the screen displays MEMORY FULL, an error tone sounds, and you will not be able to store a new number until you delete a stored number.

Edit a Number/Name Stored in the Directory

- 1 Press **▶** (DIR). The screen displays DIRECTORY.
- 2 Press **◀** or **▶** to scroll alphabetically through entries stored in memory
—OR—
Press the dial pad key for the first letter of the entry you want to edit.
- 3 When the screen displays the number you want to edit, press **SELECT**. Then press **◀** or **▶** until EDIT flashes.

EDIT DIAL ERASE
973-555-0123

- 4 Press **SELECT**. The screen displays the name and number. The flashing cursor appears at the end of the name. Use **◀**, **▶** and the dial pad keys to edit the name. Press **SELECT** to move on to edit the number. Press **SELECT** to move to edit the Distinctive Ring setting.
- 5 Press **SELECT** to save the edited information.

TELEPHONE DIRECTORY

AT THE BASE OR HANDSET

Delete a Number/Name Stored in the Directory

- 1 Press **▶** (DIR). The screen displays DIRECTORY.
- 2 Press **◀** or **▶** to scroll alphabetically through entries stored in memory
—OR—
Press the dial pad key for the first letter of the entry you want to delete.
- 3 When the screen displays the number you want to delete, press **SELECT**. Then press **◀** or **▶** until ERASE flashes.

```
EDIT DIAL ERASE
973-555-0123
```

- 4 Press **SELECT**. The screen displays ERASE NO YES and the number. The current choice flashes.
- 5 Press **◀** or **▶** until YES flashes.
- 6 Press **SELECT**. You'll hear a series of beeps confirming the deletion.

Dial a Number from the Directory

- 1 Press **▶** (DIR). The screen displays DIRECTORY.
- 2 Press **◀** or **▶** to scroll alphabetically through entries stored in memory
—OR—
Press the dial pad key for the first letter of the entry you want to dial.
- 3 When the screen displays the number you want to dial, press **PHONE** on the handset or **DISPLAY DIAL** on the base to dial the number
—OR—
Press **SELECT**. Then press **◀** or **▶** until DIAL flashes.

```
EDIT DIAL ERASE
973-555-0123
```

- 4 Press **SELECT**. The phone automatically dials the number.

CALLER ID OPERATION

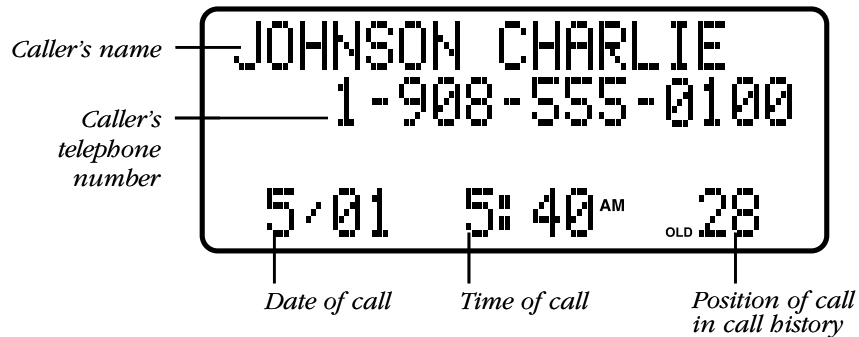

About Call History

This phone assigns each incoming call a number from 1 to 90. The most recent call will have the highest number. When the memory is full, the oldest call information is deleted to make room for new incoming call information.

For each call that comes in, the screen displays the following information between the first and second rings:

- Your caller's name (15 letters are sent by your telephone company)
- The caller's area code and telephone number
- The time and date of the call
- The position of the call in call history.

If you answer a call before the information appears on the screen, it will not be in the call history.

Note: Press **OFF** on the handset or **CLEAR** on the base at any time to exit call history.

Review Call History

The screen displays call information for about 15 seconds after it has been received.

- 1 Press **◀** (CID) to view call history. The screen displays

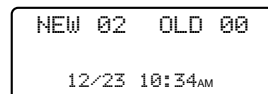

- 2 Use **◀** and **▶** to scroll through records in call history.

CALLER ID OPERATION

Delete Records from Call History

Delete a Specific Call

- 1 Locate the record you want to delete from call history.
- 2 Press **SELECT**, then press **◀** or **▶** until ERASE flashes.

```
DIAL ERASE PGM
973-555-0123
5/01 5:40PM old28
```

- 3 Press **SELECT**. The screen displays ERASE NO YES ALL and the phone number. The current choice flashes.
- 4 Press **◀** or **▶** until YES flashes.
- 5 Press **SELECT**. You'll hear a series of beeps confirming the deletion.

Delete All Calls

- 1 While viewing call history, press **SELECT**, then press **◀** or **▶** until ERASE flashes.

```
DIAL ERASE PGM
973-555-0123
5/01 5:40PM old28
```

- 2 Press **SELECT**. The screen displays ERASE NO YES ALL and the phone number. The current choice flashes.
- 3 Press **◀** or **▶** until ALL flashes, then press **SELECT**. The screen displays ERASE ALL NO YES. The current choice flashes.
- 4 Press **◀** or **▶** until YES flashes.
- 5 Press **SELECT**. You will hear a series of beeps confirming the deletion.

Dial a Displayed Number

- 1 Locate the record in call history that you want to dial.
- 2 If you wish to change how the number is dialed, press **#**. The screen displays any alternate dialing sequences available for this call (area code + number; 1 + area code + number; 1+ number; number only).
- 3 Press **PHONE** on the handset or **DISPLAY DIAL** on the base to dial the number displayed on the screen

—OR—

Press **SELECT**, then press **◀** or **▶** until DIAL flashes.

```
DIAL ERASE PGM
973-555-0123
5/01 5:40PM old28
```

- 4 Press **SELECT** when the number is correctly displayed for dialing.

CALLER ID OPERATION

Store a Call History Record in the Directory

- 1 Locate the record in call history you want to store in memory.
- 2 If you wish to change how the number is stored, press **#**.
The screen displays any alternate dialing sequences available for this call (area code + number; 1 + area code + number; 1+ number; number only).
- 3 Press **SELECT**, then press **◀** or **▶** until PGM flashes.

```
DIAL ERASE PGM
973-555-0123
5/01 5:40PM OLD28
```

- 4 Press **SELECT** three times to store the call record in memory without editing.

```
DISTINCTIVE RING?Y
973-555-0123
```

- 5 Press **◀** or **▶** to select Y or N for distinctive ring option.
- 6 Press **SELECT**. You'll hear a beep confirming that the name and number were stored.

Display Screen Messages

Screen Displays:	When:
PRIVATE	The other party is blocking name and/or number information.
OUT OF AREA	Your phone company is unable to receive information about this caller's name and/or number.

Turn Off the Base NEW CALL Indicator

After reviewing new calls, press **OFF** on the handset or **CLEAR** on the base.

ANSWERING SYSTEM OPERATION AT THE BASE

Audible Indicators

This system gives you voice prompts for feature operations and voice confirmations when you press a button or complete an operation.

Set the Clock

- 1 With answering system on, press **MENU** until the system announces, “*Change clock.*”
- 2 Press **CHANGE** until the system announces the correct day, then press **TIME/SET**.
- 3 Press **CHANGE** until the system announces the correct hour, then press **TIME/SET**.
- 4 Press **CHANGE** until the system announces the correct minutes, then press **TIME/SET**. The system announces the current clock setting.
- 5 Press an MBOX/STOP button to exit programming.

About Mailboxes

This answering system has three voice mailboxes. Callers using a touch tone phone can select the mailbox in which their messages will be recorded by pressing **ⓧ 1**, **ⓧ 2**, or **ⓧ 3** while the system plays the outgoing announcement. All other messages will be recorded in Mailbox 1.

About Announcements

- You can record up to two different announcements — one for normal answering and one for when you’ve set the system to play the announcement only.
- Use normal answering when you want the system to record callers’ messages. Use Announce Only when you want to give information to callers without accepting messages.
- If you choose not to record an announcement, the system answers with a pre-recorded announcement.
- The normal answering pre-recorded announcement says: “*Hello. Please leave a message after the tone.*” The Announce Only pre-recorded announcement says: “*We’re sorry, messages to this number cannot be accepted.*”
- By setting Announce Only to On or Off, you decide which announcement your callers will hear when the system answers a call (the system comes set for normal answering, with Announce Only turned off). See “Change Announce Only” on page 22 to change your announcement selection.

NOTE: *When the system is set to pre-recorded Announce Only, the pre-recorded announcement is played twice to the caller.*

ANSWERING SYSTEM OPERATION AT THE BASE

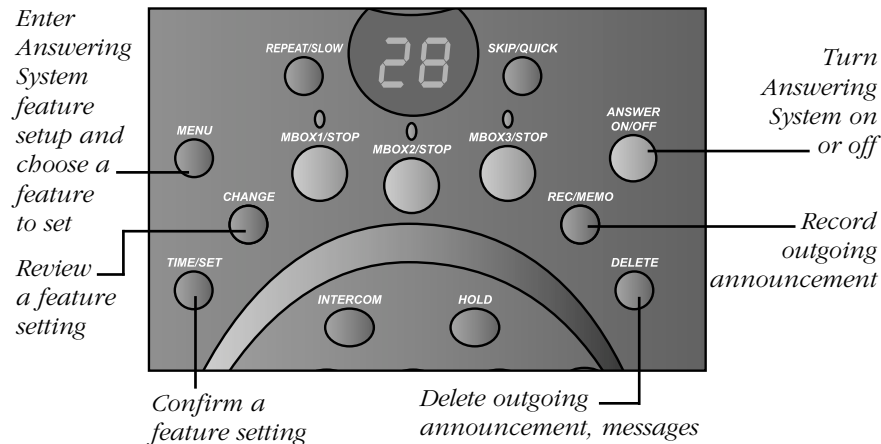

Record Your Announcement

NOTE: If you have assigned different mailboxes to different people, be sure to tell callers in your announcement to press \times 1, \times 2, or \times 3 while the announcement is playing to leave a message in the appropriate mailbox. Remember to leave a few seconds blank at the end of your recorded announcement to allow callers time to select a mailbox.

- 1 Press **MENU** until you hear "Change announcement."
- 2 Press **REC/MEMO**. After you hear "Now recording" followed by a beep, speak toward the base to record an announcement up to 90 seconds long.

NOTE: You may wish to leave several seconds of blank time at the end of your recorded announcement to allow callers enough time to select a mailbox.

- 3 Press any MBOX/STOP button to stop recording. The system plays back your recorded message.

To review your announcement at any time:

- 1 Press **MENU** until you hear "Change announcement."
- 2 Press any MBOX/STOP button.

To delete your announcement:

Press **DELETE** during announcement playback. The system will use the pre-recorded announcement until you record a new one.

ANSWERING SYSTEM OPERATION AT THE BASE

Answering System Feature Setup

You can set up one feature at a time, or you can set up a feature and then move on to set up another feature.

- 1 Make sure the answering system is on.
- 2 Press and release **MENU** until you hear the system announce the feature you want to set. Refer to the “Feature Summary” below for a description of the features and your choices.
- 3 Press **CHANGE** to hear the feature’s settings.
- 4 Press **TIME/SET** to confirm your selection.

Feature Summary

Default settings indicated by *.

System announces:	Description/directions:
“Change remote access code” 19 *	Set the remote access code you will use to access features and functions of the answering system from a touch tone phone.
“Change clock”	Set the clock: After you set the day, repeat Steps 3 and 4 in “Answering System Feature Setup” to set hours and minutes.
“Change message alert” Off * On	When Message Alert is turned on, the base beeps once every 10 seconds when new messages have been received.
“Change announce only” Off * On	When you turn Announce Only on, callers hear your announcement, but cannot leave a message.
“Change call screening” On * Off	When call screening is turned on, you can monitor both the incoming message and anyone who answers the call at another extension.
“Change number of rings” 2 4 * 6 Toll Saver	Choose how many times the phone will ring before the system answers a call. With Toll Saver active, the system answers after two rings when you have new messages and after four rings when you have no new messages.

NOTE: Exit Feature Setup at any time by pressing an MBOX/STOP button.

ANSWERING SYSTEM OPERATION AT THE BASE

Listen to, Save & Delete Messages

The system automatically saves your messages until you delete them, and can store approximately 15 minutes of messages, memos, and announcements (up to a maximum of 99 messages).

After playing a message, the system announces the day and time it was received. While the message plays, the New Message Window displays the number of the message. After playing the last message in a mailbox, the system announces “*End of messages.*” If the system has less than five minutes of recording time left, it announces remaining time.

NOTE: *Old messages you did not delete are stored in memory but do not appear in New Message Window. To review old messages you must listen to all new messages, then press the MBOX/STOP button again to hear old messages.*

Press to repeat a message; hold to slow down playback.

New Message Window

Press to skip to the next message; hold to speed up playback.



Play Messages

Press to play messages in a mailbox. Press again to stop playback.

Delete Messages

- Press to delete the message that's playing.
- Hold, then press an MBOX/STOP button to delete all messages in that mailbox.
- You cannot delete a message until it's been reviewed; deleted messages cannot be recovered.

Adjust Playback Volume

System beeps twice at highest or lowest setting.

ANSWERING SYSTEM OPERATION AT THE BASE

Call Screening/Intercept

- 1 Make sure the answering system is on, and set the message playback volume control above level 1 so you can hear the caller's message.
- 2 If you decide to take the call, press **PHONE** on the cordless handset, pick up the corded handset, or press **SPEAKER** on the base.
- 3 If you pick up an extension phone during the announcement and the announcement does not stop right away, press and release the telephone switchhook.

Record a Memo

You can record a memo up to four minutes long to store as an incoming message.

- 1 Press and release **REC/MEMO**.
- 2 Press an MBOX/STOP button to select a mailbox for the memo. After the beep, speak toward the microphone. The Message Window displays the length of your memo.
- 3 To stop recording, press the MBOX/STOP button again.

Message Window Display

Window Displays:	When:
0	No new messages in any mailbox (old messages are not counted)
1-98, flashing	Total number of messages in all mailboxes
0-99 ↔ F	Memory is full, or total number of messages is 99
Counting 1 to 99	Duration of announcement or memo recording
99, flashing	Length of recording is more than 99 seconds
1-99	Current message number during message playback
00-99	Current Remote Access Code while setting
R	Announce Only mode
ON or OFF, steady for one second	Displayed when any setting is changed from on or off
CL ↔ normal display	Clock needs to be set
--	System is answering a call or is in remote operation
--, flashing	System is in programming mode or initializing

ANSWERING SYSTEM OPERATION AT TOUCH TONE PHONE

Connect with the Answering System

You can access many features of this system remotely from a touch tone phone.

- 1 Dial your telephone number.
- 2 When the system answers, press **#**, then within two seconds enter your Remote Access Code (preset to 19). The system beeps once.
- 3 Within two seconds, enter a remote command (see "Remote Access Commands").
- 4 Press *** 0** to exit remote operation.

Voice Menu

The system has voice prompts to help you with remote operation. Press *** 5** to hear the menu while remotely connected to the answering system.

Remote Access Commands

Function:	Command:
Play messages in a mailbox	Press # , then the appropriate mailbox number (1 , 2 , or 3). The system plays new messages. If there are no new messages, the system plays old messages.
Repeat a message	Press # 4 while message is playing; each press backs up another message.
Skip a message	Press # 6 while message is playing; each press advances another message.
Stop	Press # 5 .
Save messages	Hang up.
Delete message	Press # 9 while message is playing.
Review announcement	Press # 7 ; system plays announcement, then beeps.
Record announcement	Press * 7 ; after beep, record announcement, press # 5 to stop. System plays back announcement.

ANSWERING SYSTEM OPERATION AT TOUCH TONE PHONE

Remote Access Commands (continued)

Function:	Command:
Record memo	Press * 8 ; then mailbox number where you want memo recorded; speak after beep; press # 5 to exit.
End remote access call	Press * 0 .
Turn system off	Press # 0 ; the system announces, "Machine off." Press # 0 again to turn the system back on.
Turn system on	When system is off, it answers after 10 rings and announces, "Please enter your remote access code." Press # , then enter your remote access code.

NOTE: *The remote access call will automatically end if 20 seconds go by with no key being pressed (other than when recording or playing messages or announcements).*

BATTERIES

Charge the Handset Battery Pack

- This battery should remain charged up to six days with the ringer turned on and up to 10 days with the ringer off. A fully charged battery provides an average talk time of about 10 hours.
- The battery pack needs charging when:
 - A new battery is installed in the handset.
 - The phone beeps twice every five seconds.
 - The screen displays **BATTERY LOW** and the low battery icon.
- Place the handset in the charging stand so the **CHARGING** light turns on.
The battery pack is typically fully charged in 12 hours.
- You can keep the battery fully charged by returning the handset to the charging stand after each use.
- If you repeatedly get a low battery indicator, even after charging overnight, the battery should be replaced. Use only Replacement Battery 3301 (SKU# 91076).



CAUTION: To reduce the risk of fire or injury to persons or damage to the telephone, read and follow these instructions carefully:

Charge the battery provided with or identified for use with this product only in accordance with the instructions and limitations specified in the User's Manual, Part 1.

BATTERIES

Replacing the Handset Battery Pack

- 1 **Remove the battery compartment cover** on the handset by pressing on the indentation and sliding the cover downward.
- 2 **Lift out the old battery pack and disconnect.**
- 3 **Align the two holes in the new battery pack's plug** with the socket pins, and snap the plug into place. Place the battery pack in the compartment with the wires in the lower left corner, along the bottom of the battery pack.
- 4 **Replace the cover** by sliding it up into place.
- 5 **The new battery pack must be charged before using the phone.** Place the handset in the base and allow it to charge for at least 12 hours the first charge. The telephone might operate before that, but for best performance, let the battery pack charge fully.

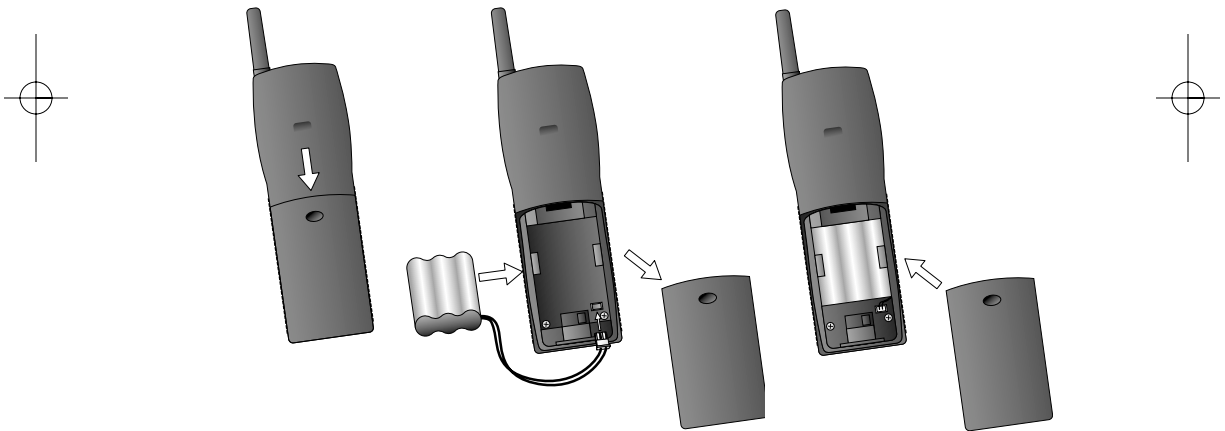

IN CASE OF DIFFICULTY

If you have difficulty operating this phone, try the suggestions below. For Customer Service, visit our website at www.telephones.att.com or call 1 800 222-3111. **Please retain your receipt as your proof of purchase.**

If the phone doesn't work at all, check these items first:

- Make sure the ringer is on at the cordless handset and base.
- Make sure the telephone line cord is plugged firmly into the base unit and the modular jack.
- Make sure the base antenna is fully upright.
- If the handset does not beep when you press **PHONE**, the battery might need charging.
- Make sure the handset battery pack is installed correctly.
- Microwave appliances may cause interference with this phone. If you experience interference, move away from the microwave

If the above suggestions don't solve the problem, try re-initializing the handset and base:

- 1 Disconnect the power to the base.
- 2 Remove the handset battery pack.
- 3 Wait a few minutes.
- 4 Connect the power to the base.
- 5 Insert the handset battery pack.

If you hear a two-beep signal when you try to use the handset:

- You might be out of range. Move closer to the base and try again.
- If moving closer to the base doesn't help, try following the directions above for re-initializing the handset and base.

If the phone does not ring when you receive a call:

- Make sure the handset ringer is on.
- Make sure the telephone line cord is connected firmly to the base and the telephone jack.
- Make sure the AC adapter is plugged firmly into an outlet not controlled by a wall switch.
- You might be too far from the base; move closer.
- You might have too many extension phones on your telephone line to allow all of them to ring. Try unplugging some of them.

IN CASE OF DIFFICULTY

If you hear noise or interference when using the cordless handset:

- Make sure the base antenna is fully upright.
- You may be out of range. Move closer to the base.
- Press and release **PROG/CHAN** to change to another of the 30 channels available. If noise is exceptionally loud, move closer to the base before changing channels.
- Household appliances plugged into the same circuit as the base can sometimes cause interference. Try moving the appliance or the base to another outlet.
- Using the handset near household appliances (microwaves, computers, television, stereos, etc.) can sometimes cause interference. Move away from appliances while using the handset.
- The layout of your home or office might be limiting the operating range. Try moving the base to another location, preferably on an upper floor.
- If the buttons don't work, try placing the handset in the charger for at least 15 seconds.

If you hear other calls while using your phone:

- Press **PROG/CHAN** to change to another channel.
- Disconnect the base from the modular jack and plug in a corded telephone. If you still hear other calls, the problem is probably in your wiring or local service. Call your local telephone service company.

If you lose a call after changing channels:

You were probably almost out of range. Move closer to the base before changing channels. Before placing another call, set the handset in the base for at least 15 seconds.

If you are unable to operate special telephone services or other equipment requiring touch tone signals:

If you have dial pulse (rotary) service, follow the directions under "Temporary Tone Dialing" in the TELEPHONE OPERATION AT THE HANDSET section of this manual.

IN CASE OF DIFFICULTY

If messages are incomplete:

- If a caller leaves a very long message, part of it may be lost when the system disconnects the call after three minutes.
- If the caller pauses for more than seven seconds, the system stops recording and disconnects the call.
- If the system's memory becomes full during a message, the system stops recording and disconnects the call. Check that all old messages have been deleted by pressing an MBOX/STOP button.

If you have difficulty hearing messages:

Check the volume setting.

If the system does not answer after the correct number of rings:

- Make sure that the answering system is on.
- If Toll Saver is on, the number of rings changes to two when you have new messages waiting.
- In some cases, the system may be affected by the ringing system used by the local telephone company.
- If the memory is full or the system is off, the system answers after 10 rings.

If CL appears in the Message Window:

You need to reset the clock.

If the system does not respond to commands from a remote touch tone phone:

- Make sure you are calling from a touch tone phone. When you dial a number, you should hear tones. If you hear clicks instead, the phone is not a touch tone telephone.
- The answering system may not detect the Remote Access Code while your announcement is playing. Try waiting until the announcement is over before entering the code.
- Make sure you enter your Remote Access Code correctly.
- There may be noise or interference on the phone line you are using. Press keys firmly.

IN CASE OF DIFFICULTY

If your outgoing announcement isn't clear:

- When you record your announcement, make sure you speak in a normal tone of voice, about nine inches from the base.
- Make sure there is no "background" noise (TV, music, etc.) while you are recording.

If callers cannot leave messages in Mailbox 2 or 3.

- Re-record your announcement, making sure to leave a few seconds blank at the end to allow callers enough time to select a mailbox. (See "Record Your Announcement" in ANSWERING SYSTEM OPERATION AT THE BASE).

© 2002 Advanced American Telephones. All rights reserved.
Printed in China. 05/02

PERF.

© 2002 Advanced American Telephones. All rights reserved.
Printed in China. 05/02

fold



DRAFT 2/20/02

**Answering System 1480
Remote Commands**

To connect with your answering system:

- 1 Dial your telephone number from a touch tone phone.
- 2 When the system answers, press **[#]**, then within two seconds, enter your Remote Access Code (preset to 19).
- 3 Within two seconds, enter a remote command from inside this card.

fold



DRAFT 2/20/02

**Answering System 1480
Remote Commands**

To connect with your answering system:

- 1 Dial your telephone number from a touch tone phone.
- 2 When the system answers, press **[#]**, then within two seconds, enter your Remote Access Code (preset to 19).
- 3 Within two seconds, enter a remote command from inside this card.

PERF.

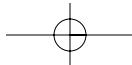
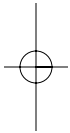

Remote Command

Voice Help menu

Play messages **Press** * 5 #, then mailbox number (1, 2, or 3)

Repeat message # 4

Skip message # 6

Stop # 5

Save messages Hang up

Delete message # 9 while message plays

Review announcement # 7

Record announcement * 7, speak after beep, press # 5 to stop

Record memo * 8, then mailbox number, speak after beep, press # 5 to stop

End remote access call * 0 # 0, system announces, "Machine off"; press # 0 again to turn system back on

Turn system off # 0, system announces, "Machine off"; press # 0 again to turn system back on

Turn system on When off, system answers after 10 rings and announces, "Please enter your remote access code"; press #, then enter your remote access code

Remote Command

Voice Help menu

Play messages **Press** * 5 #, then mailbox number (1, 2, or 3)

Repeat message # 4

Skip message # 6

Stop # 5

Save messages Hang up

Delete message # 9 while message plays

Review announcement # 7

Record announcement * 7, speak after beep, press # 5 to stop

Record memo * 8, then mailbox number, speak after beep, press # 5 to stop

End remote access call * 0 # 0, system announces, "Machine off"; press # 0 again to turn system back on

Turn system off # 0, system announces, "Machine off"; press # 0 again to turn system back on

Turn system on When off, system answers after 10 rings and announces, "Please enter your remote access code"; press #, then enter your remote access code

PERF.