

Hotpoint Service Offices

SERVICE CALL: If you have a problem with your appliance ring your local Service Office. **SPARES and ACCESSORIES:** To purchase spares and accessories send your Accessories Order Form to your Spares Centre. If the accessory or spare part you want is not on the form then contact your Spares Centre for prices and availability. Please address all correspondence to Hotpoint Spares Centre or Hotpoint Service Office as applicable.

Service Offices and Spares Centres are open between 8.30am-5.00pm Monday to Friday, 8.30am-12.30pm. Sales except on Public Holidays.

IRELAND

Northern Ireland:
256 Ormeau Road, Belfast, BT7 2TZ.
Tel: Belfast 6477111.
Fax: 35/36 Arran Quay, Dublin 7.
Tel: Dublin 7259922.
Spares and accessories may be ordered from either address.

NORTH WEST

- **KENDAL:** 28 Hoggate, LA9 4SX.
Tel: Kendal 24483.
- **PRESTON:** 24/25 Cannon Street, PR1 1JL.
Tel: Helens 40 Cowley Hill Lane, MA10 2AD. Tel: St. Helens 95152.
- **ELESBERE POINT:**
1 Church Parade, L66 2ER.
Tel: 051-356 2141.
- **STOCKPORT:** 44/46 Station Road, Heaton Mersey, SK4 3DT.
Tel: Service Office 051-442 8177.
Spares Centre 051-452 0255.

WALES

- **LLANDUDNO JUNCTION:** Conwy Road, LL31 9E2. Tel: Degeany 82828.
- **BRIDGEND:** 18 Western Avenue, Bridgend Industrial Estate, CF31 3SL.
Tel: Service Office Bridgend 641121.
Spares Centre Bridgend 641121.

WEST MIDLANDS

- **STOKE-ON-TRENT:** West Avenue, Spades and Accessories, ST7 1TN.
Tel: Kildenny 72451.
- **ALDRIDGE:** Westgate, WS9 8UX.
Tel: Service Office Aldridge 743374.
Spares Centre Aldridge 743377.

SOUTH MIDLANDS

- **DUNCOTT:** 22A Broadway, OX11 8NS.
St. Dican 817711.
Spares and accessories near authorised Hotpoint Authorised Warranty Centres.

SOUTH WEST

- **BRISTOL:** 3/5 Brington Hill, Brington, BS4 5BQ. Tel: Bristol 714471.
- **PLYMOUTH:** 69 Mulry Park, P4 6LH. Tel: Plymouth 262431.
- **TOTTON:** South Hampshire Industrial Park, Salisbury Road, SO4 3SA.
Tel: Service Office Totton 851951.
Spares Centre Totton 857333.

In accordance with its policy of progressive product design, the Company reserves the right to alter specifications.

Hotpoint Ltd, Peterborough PE2 9UB, England

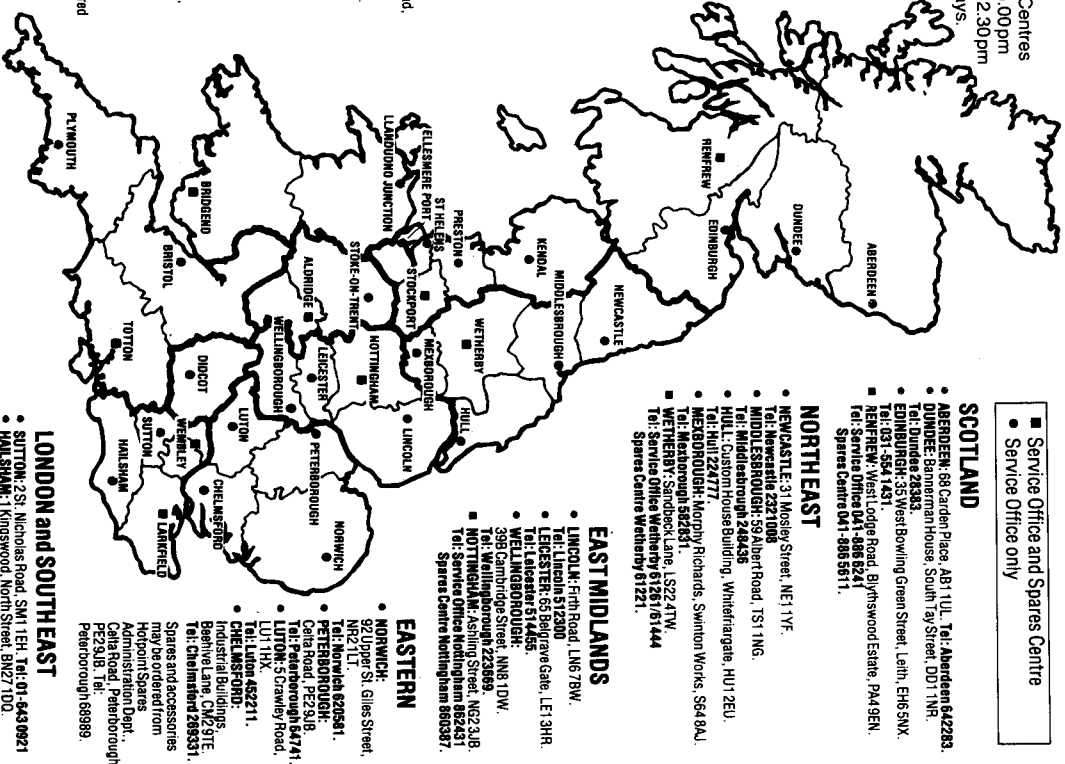

- Service Office and Spares Centre
- Service Office only

SCOTLAND

- **ABERDEEN:** 69 Carden Place, AB1 1LL. Tel: Aberdeen 642283.
- **DUNDEE:** Bannerman House, South Tay Street, DD1 1NR.
Tel: Dundee 243833.
- **EDINBURGH:** 35 West Bowling Green Street, Leith, EH6 5NX.
Tel: 131-564 1431.
- **RENFREW:** West Lodge Road, Blythswood Estate, PA4 9EN.
Tel: Service Office 01-968 5241.
Spares Centre 01-968 5811.

NORTH EAST

- **NEWCASTLE:** 31 Mosley Street, NE1 1YF.
- **MIDDLESBROUGH:** 59 Albert Road, TS1 1NG.
- **HULL:** Custom House Building, Whitehartgate, HU1 2EU.
Tel: Hull 224777.
- **MEDFORD:** Moorby Richards, Sinton Works, S64 9AU.
- **WETHERBY:** 1000 Park Road, LS22 4TW.
Tel: Service Office Wetherby 61261/61444.
Spares Centre Wetherby 61221.

EAST MIDLANDS

- **LINCOLN:** 57th Road, LN6 7BW.
Tel: Lincoln 5123200.
- **LEICESTER:** 65 Bignor Gate, LE1 3HR.
Tel: Leicester 514455.
- **WELLINGBOROUGH:**
39B Cambridge Street, NN8 1DW.
Tel: Wellingborough 230669.
- **NOTTINGHAM:** Ashing Street, NG2 2JB.
Tel: Service Office Nottingham 882451.
Spares Centre Nottingham 880387.

EASTERN

- **NORWICH:**
500-501 St. Giles Street, NR2 7ET.
Tel: Norwich 6205811.
- **PETERBOROUGH:**
Celia Road, PE2 9JB.
Tel: Peterborough 647471.
- **LUTON:** 5 Crawley Road, LU1 1HX.
Tel: Luton 4622111.
- **CHELMSFORD:**
Industrial Buildings, Denbigh Lane, CM2 9TE.
Tel: Chelmsford 659351.
Spares and accessories may be ordered from Hotpoint Spares Administration Dept., Cambridge, Peterborough, PE2 9JB. Tel: Peterborough 689899.

LONDON and SOUTH EAST

- **SUTTON:** 251 Nicholas Road, SM1 1EH. Tel: 01-543 0921
- **HAIL SHAW:** 1 Kingswood, North Street, BN27 1DQ.
Tel: Hailsham 642733
- **WIMBORNE:** 68 East Lane, HA9 7PD.
Tel: Office for S. Herts and Middlesex 01-909 1933
Spares Centre 01-904 0201.
- **LARKFIELD:** Larkfield Trading Estate, New Hyde Lane, ME20 6SW. Tel: Service Office Maidstone 718571.
Spares Centre Maidstone 718571.

HOTPOINT SLOT-IN COOKER

USER HANDBOOK AND INSTALLATION INSTRUCTIONS MODEL 6510

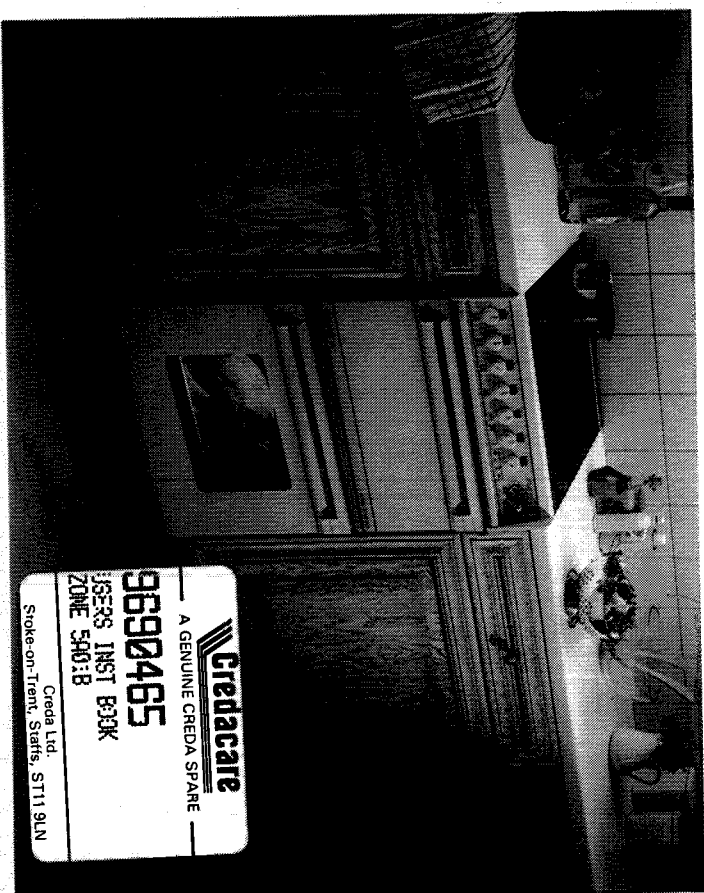

Credacare
A GENUINE CREDACARE SPARE
96980465
SERIES INST 613K
ZONE 5403B
Credac Ltd.
Stoke-on-Trent, Staffs, ST11 9LN

Hotpoint®

Before you operate your new Hotpoint Slot-In Cooker

Please read these instructions fully.

1. Ensure that the cooker is installed by a qualified electrician following the instructions below.
2. For your own safety and to get the best results from your cooker it is important to read right through this Handbook **before** using your cooker for the first time.
3. Before using the ceramic hob for the first time wipe the ceramic area with the Ceramic Hob Cleaner-Conditioner (Hotpoint Part No. 6004 – obtainable either through a local Hotpoint Service Centre or retailer).

Installation

- Any electrical wiring must be carried out in compliance with the appropriate IEE and electricity board regulations by a qualified electrician, eg. your local electricity board or a contractor who is on the roll of the National Inspection Council for Electrical Installation Contracting (NICEIC).
- **WARNINGS – INCORRECT INSTALLATION COULD AFFECT THE SAFETY OF THE APPLIANCE.**
 - ALL APPLIANCES MUST BE EARTHED.
 - BEFORE CONNECTING OR INSTALLING THE COOKER THE ELECTRICITY SUPPLY MUST BE SWITCHED OFF.
- The installer must check that the voltage shown on the rating plate corresponds with the house electricity supply.
- The cooker **must** be connected to a double pole isolating switch (cooker control unit) having a contact separation of at least 3 mm in all poles placed in a readily accessible position adjacent to the cooker.
- Access to the mains terminals is gained by removing the rear access cover.
- The mains cable must pass through the cable clamp adjacent to the terminal block. Sufficient cable should be used to allow the cooker to be pulled out for servicing.
- The main cooker control unit **must** be switched **ON** for any part of the cooker to function.
- Height adjustment. The cooker is set at its minimum height of 900 mm and this can be increased to 914 mm by plugging the levelling/height adjustment washers into the plastic foot (underneath the plinth) until the cooker is level. Before sliding the cooker into position measure the height of the units next to the cooker from the floor to the worktop at front and back. A second person should hold the cooker whilst it is lifted backwards to gain access to the foot.
Check the level of the cooker with a spirit level and make any adjustments necessary.
The maximum loading of your cooker is 11.16kW.
NOTE: Children should not be allowed to play with the appliance or tamper with the controls.

Hotpoint Service Cover

Hotpoint's Free Five Year Guarantee

From the moment your appliance is delivered, Hotpoint guarantees it for **FIVE YEARS**.

- In the Five Years all replacement parts are **FREE** provided they are fitted by our own Service Engineer. During the first Year our Engineer's time and labour is also free.
- After the first year we will charge for our Engineer's time and labour. We do, however, operate a range of Service Plans (see opposite) which for an annual payment enables you to cover any repair costs which may be necessary.
- All of our service repairs are guaranteed for twelve months in respect of our labour and any parts fitted.
- The appliance must be used in the United Kingdom and must not be tampered with or taken apart by anyone other than our own Service Engineer.
- You may, however, buy parts which can be safely fitted without specialist knowledge or equipment. The correct fitting of such parts, provided they are genuine Hotpoint spares, will not affect your Guarantee. Parts are available from our main Hotpoint Spares Centres (see back page).
- Our Guarantee does not cover the cost of any repair which is needed because of power cuts, accidents or misuse. Nor does it cover the cost of any visit to advise you on the use of the appliance. Please read the instruction book thoroughly.
- If at any time during the Guarantee period we are unable to repair your appliance, we will refund any repair costs paid to us in the previous twelve months. We will also offer you a new appliance at a reduced charge instead of a repair.
- Our Guarantee is in addition to and does not affect your legal rights.
- Should you need independent advice on your consumer rights, help is available from your Consumer Advice Centre, Law Centre, Trading Standards Department and Citizens Advice Bureau.
- All Hotpoint servicing is done by our own Service Organisation located throughout the United Kingdom and Southern Ireland. They will be happy to deal with any problems.

Hotpoint's Service Care

Whether you have just one or a number of Hotpoint appliances in your kitchen Hotpoint has a range of Service Schemes to give you complete peace of mind.

Service Cover

One annual payment covers you for all repairs for **individual appliances**.

If two or more appliances are covered a 20% reduction is made on each fee. There is also the option of **Service Cover with Maintenance** at an additional cost and both Cover Plans are renewable each year by mutual agreement.

To make sure that you have the opportunity to participate in this Plan, please complete and post the enclosed Application for Hotpoint Service Cover Plan with your remittance to your nearest Hotpoint Service Office.

Cooker Cover

One annual payment covers you for all repairs for **any number of Hotpoint Ovens, Microwaves, Hobs and Cooker Hoods** purchased. There is also the option of **Cooker Cover with Maintenance** at additional cost and both Cover Plans are renewable each year by mutual agreement.

Kitchen Cover

One annual payment covers you for all Repairs and a Maintenance Check for **all Hotpoint appliances owned** which are less than ten

years old. Kitchen Cover also covers loss of food up to the value of £250 in our refrigerator and freezer products. Any additional Hotpoint appliances purchased after you have joined **Hotpoint Kitchen Cover** will automatically be included during the current annual period of cover without any further charge.

Full details and costs of these Service Plans can be obtained from your local Service Office (see back page).

Annual Safety/Maintenance Checks

Hotpoint strongly recommends that all its appliances are regularly checked for electrical and mechanical safety whether or not they are covered by a Service Plan.

Proof of Purchase

For future reference please attach your purchase receipt to this booklet and keep it in a safe place.

Spares and Accessories

Spares and accessories can be ordered from your local Hotpoint Spares Centre (listed on the back page), using the order form enclosed.

Contents

	page
Before you operate your new Hotpoint Slot-In Cooker	2
The main parts of your Cooker	4
Changing the Main Oven door hinging	5
The cooking systems in your Cooker	6
The Controls	7-8
The Timer	9-10
Using and Cleaning the Ceramic Hob	11-13
Top Oven – Grilling	14
Top Oven – Conventional Cooking	15
Main Oven – Fan Cooking	16
Main Oven – Fan Grilling	17
Care and Cleaning of the Cooker	18-20
If something goes wrong	21
If it still won't work	21
Hotpoint Service Cover	22
Hotpoint Service Offices and Spares Centres	back page

Retention of the Instruction Book

This Instruction Book must be kept handy for reference as it contains important details on the safe and proper use of the appliance.

If you sell or pass the appliance to someone else, or move house and leave it behind, make sure this Book is also provided so the new owner can become familiar with the appliance and safety warnings.

If the Book is lost or damaged a copy must be obtained from Hotpoint Ltd, Celta Road, Peterborough, PE2 9UB.

The Main Parts of your Cooker

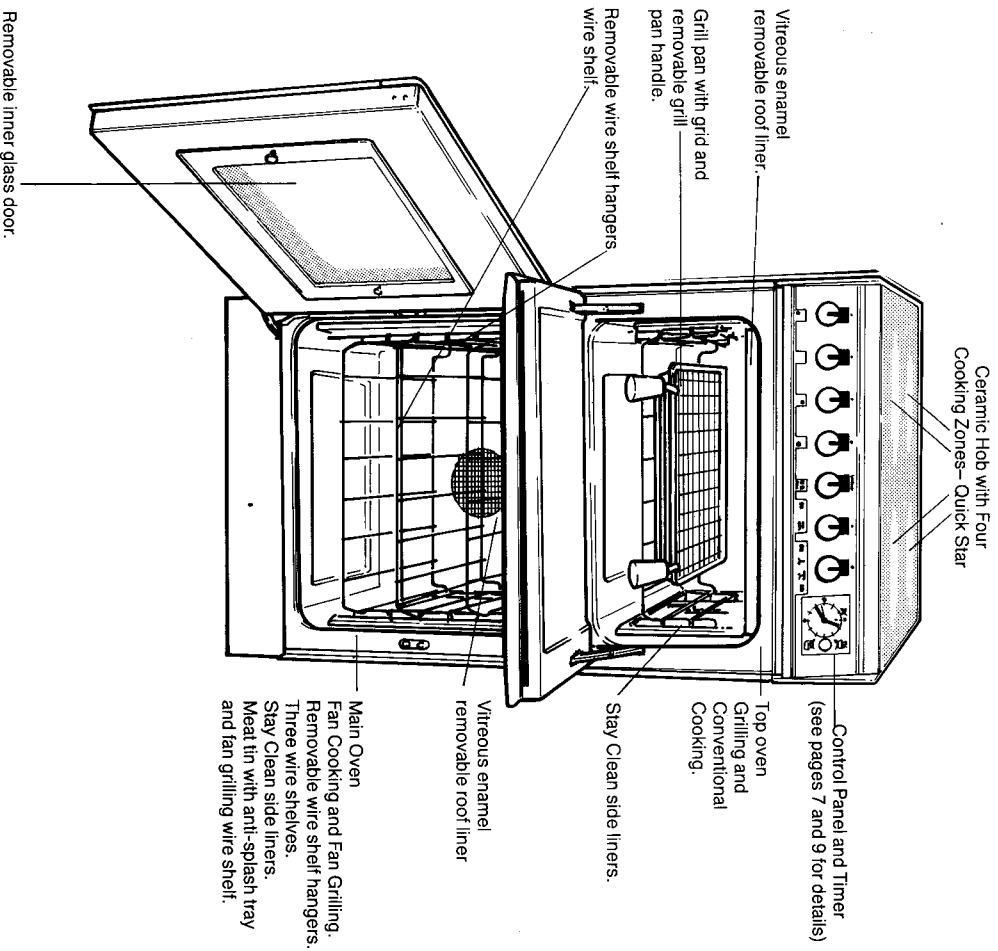

If something goes wrong . . .

First, don't panic! There may be nothing wrong. Check the points below before calling your Hotpoint Service Office.

1. Check that the mains supply is switched on.
2. Check that the Automatic Cooking Programme has not been selected: if it has switch the oven back to Manual control (see page 10).
3. If using the Grill in the Top Oven make sure that the Top Oven Control is set to 'O' Off (see page 7).

If it still won't

WORK . . .

Contact the Service Office

If there is still a problem with your Cooker after checking the points above:

1. Switch off the Cooker at the cooker control panel.
2. Call your nearest Hotpoint Service Office or local importer (outside the UK). The telephone number is shown on the back page. Note the number down in the space below:

.....

When you contact us we will want to know the following:

1. Your name, address and post code.
2. Your telephone number.
3. Clear and concise details of the fault.
4. The model number (6510) and the colour.
5. The date of purchase. Enter the date here:

6. If you have taken out one of the Hotpoint Service Schemes.

Please make sure you have all these details ready when you call.

Reversible Main Oven Door (see opposite).

removed with a fine steel wool soap pad.

Top Oven/Grill Cleaning

Clean grill pan and grid as soon after use as possible to prevent stains being burnt on when the grill pan is used again.

Wipe up any spillages as soon as possible to prevent them from being burnt on.

Cleaning the Exterior of the Cooker

The outside of the cooker should be cleaned regularly to keep it looking like new.

Wipe over with a soft cloth wrung out in hot water and dry with a soft clean cloth. Wear protective gloves.

You can use mild non abrasive cleaners but always read the manufacturer's instructions first. Always test their suitability on a small area of the cooker not noticeable in normal use.

NOTE: DO NOT use scouring pads or abrasive powder which will scratch the glass.

Changing the Main Oven door hinging

WARNING: Switch off the electricity supply to the cooker at the cooker control unit before changing the door hinging.

A pack of fittings is supplied with the information pack in the cooker. This contains:

- 50 mm double sided tape
- Door pull sticker
- Right hand door stay

You will need a No.2 Posidriv screwdriver.

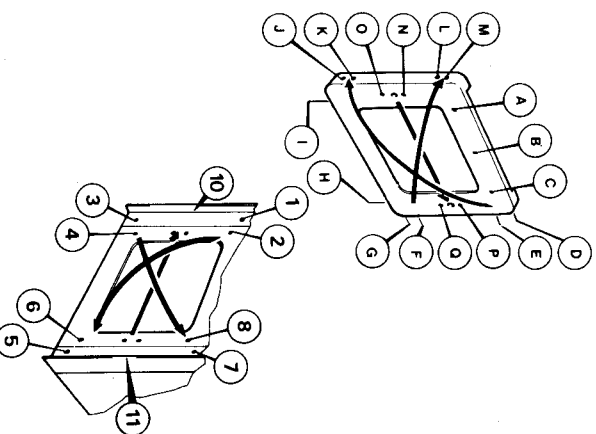

1. Open the door fully. Place padding under the door to support the door during the removal of the hinges.
2. Remove the door stay, which is the small metal bracket adjacent to the hinge, which prevents the oven door opening more than 110°. In order to gain access to the screws the appliance will require tilting backwards and be carefully supported.
3. Unscrew screws and remove hinge and hinge shim at positions 1 and 2. Replace hinge at 5 and 6, replace hinge shim at 7 and 8. **Note:** The screws in the hinges should be removed and replaced one at a time. Only loosely fit screws No. 5 and No. 6 at this stage, to allow you to slot the door into position.
4. Unscrew and remove hinge and hinge shim at positions 3 and 4. Replace hinge at 7 and 8, replace hinge shim at 5 and 6. **Note:** Replace steel washer on the lower hinge. Only loosely fit screw No. 7 at the top to

allow you to slot the door into position. Retain screw No. 8 on one side for use later.

5. Place the door on a flat surface.
6. Remove screws A, B and C and H and I to remove the inner panel from the outer glass and handle.
7. Remove door catch N and O and blanking plate P and Q and replace on opposite sides of the door. A 7 mm spanner may be required.
8. Remove screws M and L, K and J. Also remove screws D, E, F and G holding door side hinges and replace at J, K, L and M as shown in illustration. Screws D, E, F and G should then be placed in positions M, L, K and J. **Note:** Hinges replaced diagonally, do this one at a time to avoid confusion.
9. Replace the glass and inner panel and replace screws H and I. Place the handle into position and replace screws A, B and C. **Note:** If round door spacers at the handle have become dislodged, replace using the double sided tape provided. Replace all fibre washers.
10. Transfer the door striker from the right '11' side to the left '10' side by interchanging the door striker and upper blanking screw only. Do not remove the adjacent lower screw fixings.
11. Place door on bottom hinge and place top hinge in position, tighten screws No. 5 and No. 6. Replace screw No. 8 and tighten screw No. 7.
11. Some adjustment of the door striker may be necessary at this stage. With the door moved to a position where the door catch meets the striker, the striker must be located in the centre of the door catch aperture. If the striker does not locate centrally in the door catch, vertical adjustment may be obtained by slackening the door striker locknut and the posi-screw, then the striker can be moved up or down as required. With the door closed the head of the striker must be fully engaged by the door catch. It is important after changing the door over, to check the door seal by closing the door over, to check the door seal by closing the door onto a 2 in wide strip of paper (news/paper thickness), there should be resistance to the withdrawal of paper at all points around the seal, if the door seal does not grip the paper, or if it is too tight, adjustment can be obtained by slackening the locking nut on the striker and screwing it in or out as necessary then relocking the nut.
12. Fit right hand door stay using screw and spacer removed from left hand door stay.
13. Remove the 'door pull' sticker from its original position and reposition new sticker at the end of the handle away from the hinges.

The cooking systems in your Cooker

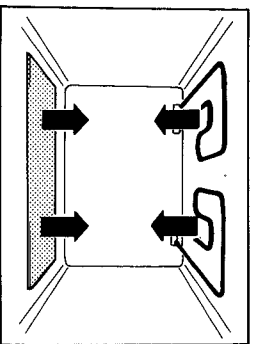

Your new cooker is equipped with four different cooking systems:

1. **Conventional Heating** [Top Oven] – with upper and lower heat. This system is particularly suitable for roasting and baking on one shelf only.

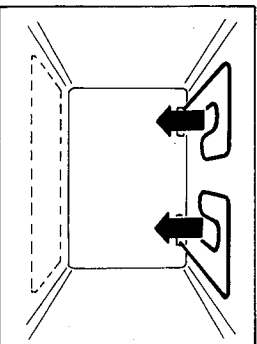

2. **Variable Grilling** [Top Oven] – the oven can also be used for conventional grilling with a full or half width fully controllable grill. **Note: The Top Oven Door should be open when grilling.**

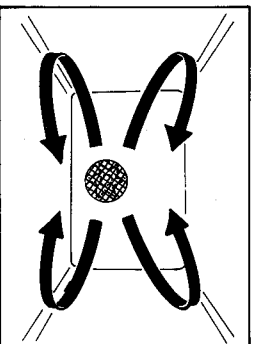

3. **Fan Cooking** [Main Oven] – the fan operates by constantly blowing heated air, from an element wrapped around the fan, into the oven. This gives improved efficiency and, in general, enables the use of lower temperatures for cooking. It also means that there is less need to be particular about shelf positions and that you can bake at more than one level simultaneously (Batch Baking).

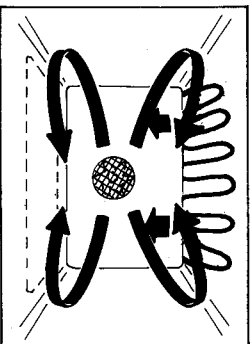

4. **Fan Grilling** [Main Oven] – this is a combination of heat from the grill element and hot air circulated by the fan. Joints of meat and poultry will be browned as if they were cooked on a rotisserie or spit but more economically as the door is left closed.

PLEASE NOTE that when the cooker is used for the first time a slight odour may be emitted due to the 'burning off' of any temporary finish on oven fittings and elements and the removal of moisture absorbed by the lagging. The odour will cease after a short period of use.

These four systems of cooking are described more fully in the separate Recipe Book and we would suggest you read right through the Introductory Section of that book **before** using the oven.

After cleaning, rinse and dry with a soft cloth and refit the door:

- Make sure that the face marked 'IMPORTANT. This Face Towards Oven' is facing inwards.
- Refit the two screws with the two washers. Do not overtighten the screws.

WARNING: DO NOT RUN THE OVEN WITHOUT THE INNER DOOR GLASS FITTED.

Oven Door Cleaning – Top Oven/ Grill

The Top Oven door is removable to facilitate the occasional cleaning of heavy soiling from the oven floor and from the door itself.

To remove, open the top and main oven door fully and, using a coin or screwdriver, turn the two discs clockwise to the position shown below (Fig. a). Part close the door to approx. 45°, unhook the lower hinge fingers, then pull the door away from the body of the cooker.

To replace, insert the lower fingers and hooked ends of the door stays, ensuring that the slots in the lower fingers engage with the front frame (Fig. b). Fully open the door and turn the discs anticlockwise to their normal working positions (Fig. c). **NOTE:** Take care not to trap your

fingers. Ensure that assistance is at hand should it be required. Wipe over with a soft cloth wrung out in hot soapy water and dry with a soft clean cloth. Wear protective gloves. **DO NOT** use scouring pads or abrasive cleaners as they may scratch the surface.

Oven Interiors

To clean the oven interiors remove all the oven fittings and if necessary the 'Stay Clean' liners.

All types of oven cleaners can be used, but **do not** allow abrasive cleaners or oven spray to come into contact with the 'Stay Clean' liners. Use a fine steel wool soap pad to remove stubborn stains.

Oven Door Cleaning – Main Oven

The inner door glass on the Main Oven can be removed for easy cleaning as follows:

- Open the door fully.
- Unscrew the two retaining screws taking care not to lose the two washers fitted underneath the screw head. Also take care not to drop the glass as you are taking it off.

The glass can now be cleaned at the sink. Stubborn stains can be

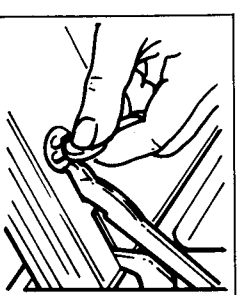

Fig. a

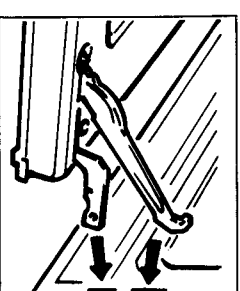

Fig. b

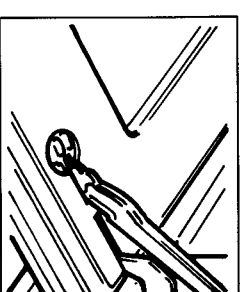

Fig. c

Care and Cleaning of the Oven

WARNING: BEFORE CLEANING SWITCH THE COOKER OFF AT THE COOKER CONTROL PANEL AND ALLOW IT TO COOL.

'Stay Clean' Liners

'Stay Clean' liners are fitted to the sides of the Top Oven, and to the roof, sides and back of the Main Oven. All the liners except the back panel of the Main Oven can be removed to be cleaned and to allow cleaning of the oven.

'Stay Clean' liners are covered with a special enamel which absorbs cooking soils. At higher temperatures the soiling is slowly destroyed. In most cases normal cooking at higher temperatures will permit this cleaning to take place automatically.

However, if higher cooking temperatures are not used regularly then it may be necessary, in order to prevent heavy soiling, to run the oven at maximum temperature for at least two hours, from time to time.

Should it be necessary, the 'Stay Clean' side and roof panels can be removed.

The roof liners simply slide out.

To remove the Stay Clean liners in both the top and main ovens – push the shelf runners upwards releasing them from their retaining position. Remove the shelf runners and the 'Stay Clean' liners totally.

The 'Stay Clean' liners can then be washed in warm soapy water followed by rinsing in clear water. Dry well with a soft cloth.

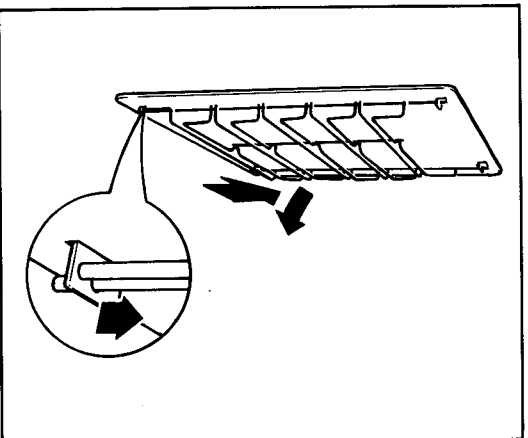

NOTE: Do not use enzyme washing powder, harsh abrasives or chemical oven cleaners of any kind.

Do not wash them in a dishwasher.

Oven Fittings

The shelf runners can be removed as described on the previous page. They and the wire shelves can be cleaned either in a dishwasher or by using a fine steel wool soap pad.

The grill and meat pans can be cleaned in warm soapy water using a fine steel wool soap pad to remove stubborn stains.

NOTE: DO NOT use scouring pads or abrasive powder which will scratch the glass.

Take particular care when cleaning the inner surface which is coated with a heat reflecting surface.

The Controls

Switch on the electricity supply to the cooker at the Cooker Control Unit.

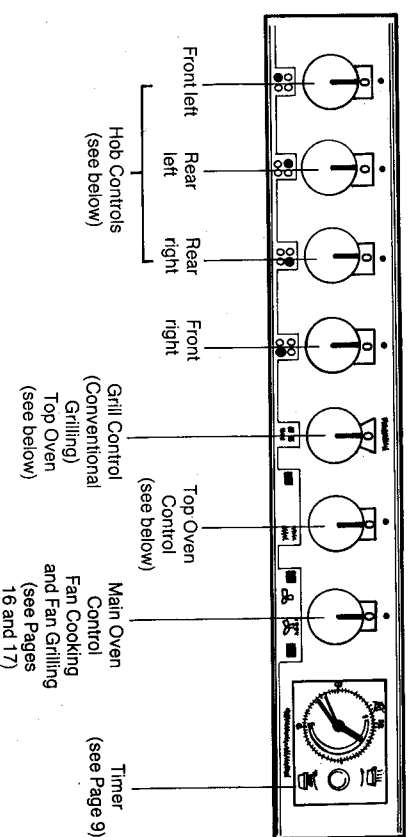

Hob Controls

As each control knob is turned clockwise or anti-clockwise figures from 1-5 then Hi appear in the window above the control knob.

Setting Hi is the highest/hottest and gives 100% power. Setting 1 is the lowest/coolest and gives about 7% power (see page 11 for ratings).

Variable power is obtainable on each of the heating areas by selecting any number between 1-5 then Hi. The 'off' position is identified by a red 'O'.

The control knobs for the hob heating areas can be rotated in either direction to provide fully variable heat control.

Grill Control – Top Oven

The grill will not operate unless the top oven control is in the 'off' position. The grill control provides fully

variable heat control for either the twin grill or single (left hand side) grill by selecting any number between 1 to 4 and Hi.

When turned clockwise the twin grill will be switched on and any power setting from 1 to 4 and Hi can be selected. The power level numbers are indicated in red. When turned anti-clockwise the single grill will be switched on and any power level from 1 to 4 and Hi can be selected. The power level numbers are indicated in green. The 'off' position is identified by a red 'O'.

Top Oven Control

This control switches on the top and bottom heating elements in the top oven.

The temperature in the top oven can be set anywhere between 100°C and 220°C.

Main Oven – Fan Grilling

The heat for Fan Grilling is provided by the grill element at the top of the oven and this heat is circulated around the food by the fan.

Fan Grilling is designed to give an effect similar to Spit Roasting without the need to provide and clean additional fittings in the oven. Joints of meat and poultry will be browned as though they were cooked on a rotisserie or spit. You can grill by this method any meat from a thick chop to a large turkey.

The operation of the controls is covered on pages 7 and 8.

Detailed charts covering suggested temperatures and shelf positions are given in the recipe book supplied.

To use the oven proceed as follows:

- Place the oven shelf in position. Place the meat tin with anti splash tray and shelf onto the oven shelf.
- After turning the Main Oven control clockwise to the  position turn control back to set the correct temperature required.
- Place the food to be cooked in the centre of the shelf directly over the meat pan.
- Turn the food over half way through the cooking time. Take care as oven will be hot – always wear oven gloves.

WARNING: Take care as oven/grill will be hot. Always wear oven gloves. Hold the meat tin with both hands when removing from the oven on completion of cooking.

The red thermostat light will glow initially and remain on until the oven reaches the required temperature. It will then cycle off and on as the oven thermostat maintains the correct temperature.

The 'off' position is identified by a red 'O'.

The top oven control can only be turned clockwise.

Main Oven Control

This control switches on the Main oven and is also used to select either the Fan Cooking or the Fan Grilling options.

1. To select Fan Cooking:

Turn the control clockwise and select any temperature between 70°C and 230°C.

As the control is turned the fan will start, the oven interior light and the orange Main Oven thermostat light will come on and the element around the fan will start heating.

The fan and oven interior light will remain on throughout cooking. The red thermostat light will come on and remain on until the oven reaches the required temperature. It will then cycle off and on as the oven thermostat maintains the correct temperature.

2. To select Fan Grilling:

Turn the control past the 230°C mark to the  setting then turn the control back to set the correct temperature required. The element around the fan will be switched off and the grilling element switched on.

Apart from a different element being used to provide the heat, the oven will operate in the same

way as for Fan Cooking.

When the control is returned to the 'O' off position, it will be reset automatically to select Fan Cooking or Fan Grilling when the Main Oven is next switched on.

Notes

1. **Never** operate **both** the top oven grill control and top oven control together. The grill will not operate unless the top oven control is in the 'O' off position.
2. When the main oven door is opened a switch automatically disconnects the fan and heating element. These are reconnected when the door is closed.
3. If either oven does not switch on when the control is turned check that the timer is in Manual operation (see page 10).
4. The oven shelf in the top oven can be removed and used in the main oven if required.
5. To remove the oven shelves – pull the shelf towards the user until the 'stop' position is reached. Lift the shelf slightly and withdraw. To replace – lift the shelf and ensure that the shelves are firmly in position between the shelf runners. Lower the shelf and push into position.

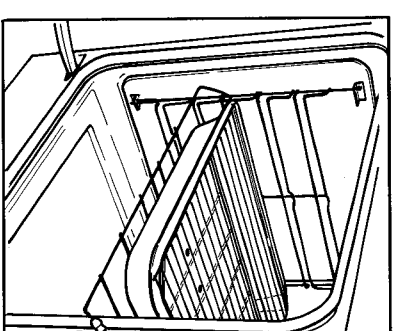

Main Oven – Fan Cooking

The heat for Fan Cooking in the Main Oven is provided by an element situated at the back of the oven and around the fan.

Fan cooking is ideal for large poultry or joints of meat, reducing cooking times and often eliminating the need for preheating the oven. It is also ideal for batch cooking where food is cooked on more than one level, because the forced circulation of hot air gives a very even temperature from the top to the bottom of the oven.

The operation of the controls is covered on pages 7 and 8. Detailed charts covering suggested temperatures and shelf positions for Fan Cooking are given in the recipe book supplied.

To use the oven proceed as follows:

- Set the Main Oven control to the required temperature. Pre-heating is not normally necessary, but some foods such as bread, scones and Yorkshire pudding do benefit from being placed in a hot oven (see recipe book supplied).
- Place the food to be cooked in the centre of each shelf to allow for even air circulation around the food.
- When roasting use the anti splash tray beneath the meat to avoid excessive splashing of the oven.

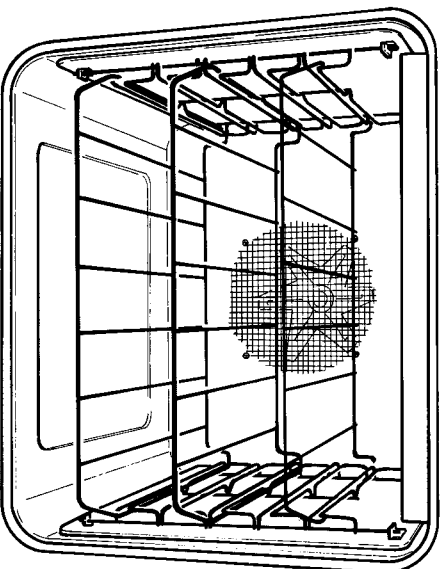

The Timer and its operation

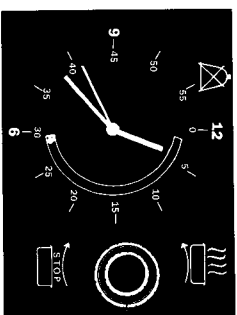

Outer knob – clockwise
Cooking completion time
Outer knob anti-clockwise
cooking duration

The Timer can be used to automatically switch on either oven independently or both ovens simultaneously. It can also be used as a minute minder and clock.

Hints on Automatic Cooking

1. Select foods which will take about the same time to cook, and require approximately the same oven temperature.
2. Foods which discolour should be protected by coating in cooking oil, or tossing in water to which lemon juice has been added.
3. Foods should be well sealed in dishes, to prevent the loss of liquid during cooking. Aluminium foil makes a good seal.

Switching On – manual operation

1. Make sure the cooker is switched **On** at the main cooker control unit.
2. Check that the timer is showing the correct time of day.

1. **Setting Time of Day**
Push in the small inner knob and turn clockwise or anti-clockwise as required.

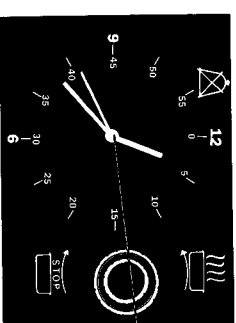

Setting time of day

2. **Setting on Automatic Cooking Programme**
Setting cooking completion time

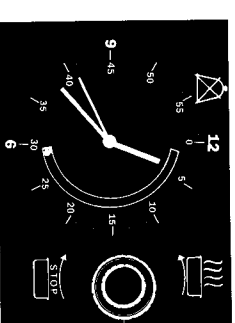

Start/Stop
Auto timer

Turn the larger outer knob clockwise until the smaller circular stud is opposite the required end time. A maximum end time of up to 11 hours ahead and a minimum end time of 30 mins ahead can be set.

Top Oven – Conventional Cooking

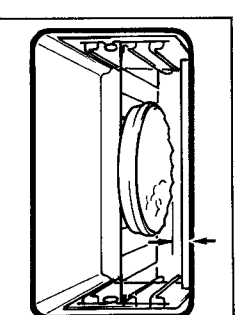

Platewarming in the Top Oven

Plates and dishes placed on the floor of the Top Oven will be heated when the Main Oven is in use. When the Main Oven is not in use (for instance when a meal is being cooked on the hob) place the plates and serving dishes on the shelf using the bottom runner, and turn the Top Oven control to approximately 100°C. A maximum time of 10-12 minutes is all that is required to heat the plates and dishes.

Do not operate the grill control when using the Top Oven for cooking or for warming plates and dishes.

WARNING: DO NOT PUT DELICATE CHINA OR ITEMS WHICH COULD BE AFFECTED BY HEAT INTO THE OVEN.

cannot heat up. Before seeking assistance, make sure you have done this.

3. Minute Minder

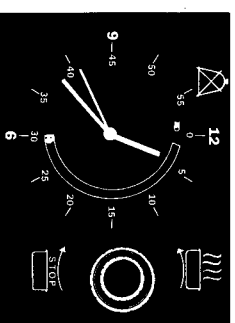

The minute minder operates independently from the automatic cooking programme. Turn the small inner knob (without pushing in) clockwise or anti-clockwise and set the time required up to 55 minutes. When the time set has elapsed there is an audible signal, which can be stopped by turning the knob to the symbol 'bell off', the audible signal also ceases automatically after 2 minutes. Before setting commences, the green pointer should always be in the 'bell off' position. Point to note: When one oven is set to operate on the automatic cooking programme the other oven cannot be used manually.

Setting cooking duration

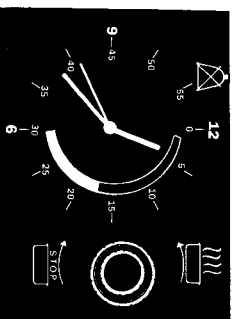

Turn the larger outer knob anti-clockwise. The red arc will appear on the clockface. Turn the knob until the required duration has been set. The start of the red arc denotes the cooking start time. Whilst the cooking programme is running, the red arc turns back with the hour hand, slowly disappearing. At the end of the cooking programme, the symbol 'O' appears in the window.

To reset the timer to Manual

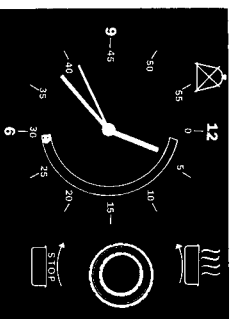

To reset the timer to manual operation, turn the larger outer knob until the hand symbol appears in the window.

Note: The maximum cooking duration which can be set is 3 hours.

IMPORTANT: Before using your oven for non-automatic timed cooking, ALWAYS make sure that the timer has been set to MANUAL operation (see paragraph above). Unless this is done the oven

The heat for conventional cooking in the Top Oven is provided by the grill element and the element under the floor of the oven. It is ideal for the slow cooking of cheaper cuts of meat in casseroles etc but can also be used for small joints of meat up to 1.5kg (3lb).

The operation of the controls is covered on pages 7 and 8.

Detailed charts covering suggested temperatures and shelf positions for cooking are given in the recipe book supplied.

The Top Oven can be used either independently to cook small quantities of food or in conjunction with the Main Oven to provide additional cooking space.

To use the oven proceed as follows:

- The shelf should be positioned on the first or second runner from the bottom.
- Set the Top Oven control to the required temperature and wait for the thermostat light to go off indicating that the oven has reached the right temperature.
- The food to be cooked should be placed in the centre of the shelf with a gap of at least 25mm (1 in) between it and the grill element. This should avoid burning and ensure even cooking.
- **Do not place food or dishes on the floor of the oven.**

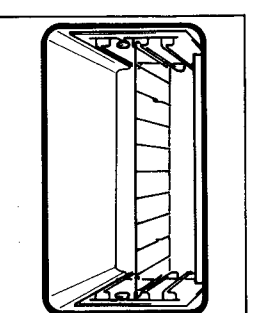

Top Oven – Grilling

Grilling must be done with the top oven door open.

CAUTION: ACCESSIBLE PARTS MAY BECOME HOT WHEN THE GRILL IS IN USE – CHILDREN SHOULD BE KEPT AWAY.

The operation of the controls is covered on pages 7 and 8.

Remember that the grill will not operate until the Top Oven control is in the 'O' off position.

To operate the grill proceed as follows:

- Open the Grill/Top Oven door.
- When toasting or grilling, the rod shelf should be placed in the second or third runner from the bottom.
- Preheat the grill on setting HI for approximately 5 minutes, using either the half or full width setting depending upon the amount of food to be cooked (see page 7).
- Fix the grill pan handle securely in position. With the grill pan handle in the vertical position place the chrome section centrally over the grill pan lip. Drop handle away from the grill pan and ensure handle is secure before use (see illustration). The food to be cooked should be placed on the grill pan/ grill pan grid. Place the grill pan on the shelf and push back until the grill pan touches the rear of the oven cavity.
- Food which only requires browning should be placed directly on the shelf on the first or second runner from the bottom.

• Leave the control on setting HI for toast and for the sealing and fast cooking of foods. For thicker foods requiring longer cooking turn the control to a lower setting after the initial sealing on both sides on setting HI. The thicker the food the lower the control should be set.

Warning: Take care as oven/ grill will be hot – always wear oven gloves. Always ensure that the grill pan is clean BEFORE use.

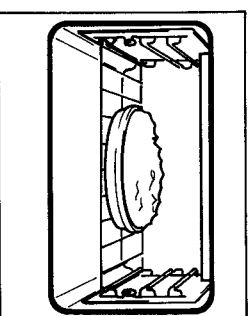
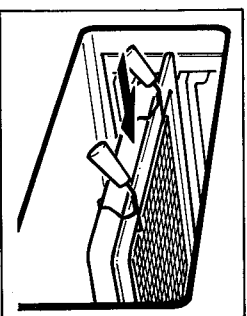
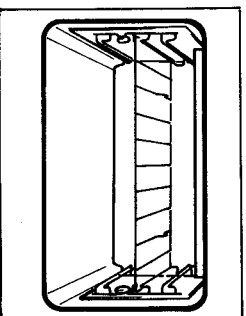

Using the Ceramic Hob

WARNING: DO NOT USE THE HOB IF IT IS CRACKED. SWITCH OFF AT THE COOKER CONTROL PANEL IMMEDIATELY AND CONTACT YOUR NEAREST HOTPOINT SERVICE OFFICE (SEE BACK PAGE).

Ratings of Cooking Zones

Front Left	Quick Star 1700W	180 mm diameter
Front Right	Quick Star 1200W	145 mm diameter
Back Left	Quick Star 1400W	160 mm diameter
Back Right	Quick Star 1700W	180 mm diameter

The Working of the Heating Zones

Heating only occurs within the marked circular cooking zones. Each heating zone is equipped with a thermal limiter which is a safety cut-out which prevents the ceramic glass from overheating. After several minutes at full power the thermal limiter will switch the heating elements off and on automatically to avoid any damage to the ceramic glass.

Choice of Saucepans

It is essential that the saucepans you use on the ceramic hob are suitable.

DO USE:

- Good quality pans with smooth, flat, heavy bases.
- Saucepans manufactured from aluminium (enamelled or machined) or stainless steel.
- Correct size saucepans. The base of the pan must cover the heating zone completely.
- Saucepans with lids which are well fitting to reduce cooking time and energy use.

DO NOT USE:

- Pans with thin, distorted or uneven bases as these will extend cooking times, waste electricity and cause damaging, local hotspots on the glass surface.
- Pans with ridged or recessed bases.
- Pans with damaged or rough bases which could scratch the glass surface.

Care of the Ceramic Hob

In order to keep your Ceramic Hob in good condition follow these simple guidelines:

- **Do not** use the surface for chopping and cutting as this will damage the smooth surface.
 - **Do not** cook directly on the surface of the glass.
 - Lift pans when moving them on the hob, **do not** slide them as this could cause scratches.
 - Make sure that the bottom of the pan is both clean and dry. Dirt or moisture between the pan and the hob can cause pitting of the surface of the glass.
 - Cover the heating zone completely with the saucepan.
 - **Do not** leave heating zones uncovered when they are on.
 - Clean spills immediately. (See below for advice.) If the hob is reused before cleaning, spillage will be baked on and be very difficult to remove.
 - **Do not** allow aluminium foil or plastic items to come into contact with the hot surface.
 - Take extra care when cooking foods with a high sugar content eg. jam as spillage will cause damage to the surface of the glass.
 - **Do not** place anything between the saucepan base and ceramic glass surface (eg. cooking mats, etc).
- Cleaning the Ceramic Hob**
Before cleaning switch the cooker **OFF** at the cooker control panel.
- Avoid spills wherever possible.

- Use a Ceramic Hob Cleaner-Conditioner before using for the first time and subsequently whenever cleaning is done. The Cleaner-Conditioner forms a protective film on the hob and contains a mild detergent which makes cleaning easier. Hotpoint has a Cleaner-Conditioner which can be obtained either through a local Hotpoint Service Centre or retailer, part No. 6004.

To clean off stubborn stains the following can be used when the surface has cooled:

1. Jif, non-scratch cream cleaner.
2. Heavy soil can be shaved off the surface by **carefully** using a glass scraper.
3. Hard water stains, grease spots and any discolouration having a metallic sheen can be removed with Solvol Autosol Super or any **non abrasive** stainless steel cleaner.

After cleaning, using these methods, always use the Cleaner-Conditioner and finish it off by polishing with a clean, dry paper towel.

Never use abrasive or chemical oven cleaners as they can damage the surface of the Hob.
The visual effect of any scratches which may occur in use can be minimised by the use of Cleaner-Conditioner. Such scratches cannot be removed but do not affect the function of the hob in any way.

Safety Recommendations for Deep Fat Frying

The following recommendations should be followed:

- a) **Never** leave the pan unattended on the heat, eg. to answer the telephone.
- b) Always use a deep pan large enough to cover the cooking zone.
- c) **Never** fill the pan more than one third full with oil or fat. On no account mix oil and fat.
- d) **Do not** overload the pan by trying to fry too much. The pan containing oil and food should **not** be more than two thirds full.
- e) Always dry food thoroughly before frying and lower it slowly into the oil.
- f) **Do not** use a lid on the pan.
- g) Always keep the outside of the pan clean and free from fat and oil.
- h) **Do not** allow excessive splashing of oil onto the hob.

In the event of fire follow these steps:

1. If a saucepan or chip pan catches fire **TURN OFF THE HEAT IF SAFE TO DO SO**, using the control on the front of the cooker.
2. **DO NOT** attempt to move the pan, this may cause the fire to spread to other areas.
3. **DO NOT** use **WATER** to put out the fire. If available use only an **APPROVED FIRE EXTINGUISHER** for the purpose, ie. **DRY POWDER, CO₂**, or **HALON**.

4. If a **FIRE EXTINGUISHER** is **NOT** available, smother the flames with a **DAMP CLOTH; SAUCEPAN LID or FIRE BLANKET**.

When smothering the flames **DO ENSURE** that your **FACE AND ARMS** are **WELL PROTECTED** from the flames to save you from becoming hurt.

5. After the fire has been extinguished **DO NOT MOVE OR TOUCH** the pan for at least 30 minutes.
6. If you **FAIL** to put the fire out call the fire brigade immediately.