

EN

User manual

Cooker

# USER MANUAL

ZCG661

GB IE

*la vita è bella*  
**ZANUSSI**  
ITALIAN SINCE 1916

# Contents

Safety information _____	2	Oven - Care and Cleaning _____	15
Product description _____	5	What to do if... _____	16
Before first use _____	6	Installation _____	18
Hob - Daily Use _____	6	Environment concerns _____	21
Hob - Helpful hints and tips _____	7	GREAT BRITAIN & IRELAND - Guarantee/Customer	
Hob - Care and Cleaning _____	7	Service _____	21
Oven - Daily Use _____	8	www.electrolux.com _____	22
Oven - Helpful hints and tips _____	9		

Subject to change without notice



## Safety information

Before the installation and use, read this manual carefully:

- For your own safety and the safety of your property
- For the protection of the environment
- For the correct operation of the appliance.

Always keep these instructions with the appliance also if you move or sell it.

The manufacturer is not responsible if incorrect installation or use results in damage.

### Children and vulnerable people safety

- Do not let persons, children included, with reduced physical sensory, reduced mental functions or lack of experience and knowledge to use the appliance. They must have supervision or instruction for the operation of the appliance by a person who is responsible for their safety.
- Keep all packaging away from children. There is the risk of suffocation or physical injury.
- Keep children and animals away from the appliance when the door is open or the appliance is in operation. There is the risk of injury or other permanent disability.
- If the appliance has Child lock or Key lock function, use it. It prevents children and animals from accidental operation of the appliance.

### General safety

- Do not change the specifications of this appliance. There is the risk of injury and damage to the appliance.
- Do not let the appliance stay unattended during operation.
- Switch off the appliance after each use.

### Installation

- Only an approved technician can install and connect the appliance. Contact an approved service centre. This is to prevent the risks of structural damage or physical injury.
- Make sure that the appliance is not damaged because of transport. Do not connect a damaged appliance. If necessary, contact the supplier.
- Remove all packaging, stickers and layers from the appliance before first use. Do not remove the rating plate. It can invalidate the guarantee.
- Fully obey the laws, ordinances, directives and standards in force in the country where you use the appliance (safety regulations, recycling regulations, electrical or gas safety rules etc.).
- Be careful when you move the appliance. The appliance is heavy. Always use safety gloves. Do not pull the appliance by the handle.
- Make sure that the appliance is disconnected from the power supply during the installation (if applicable).
- Keep the minimum distances to the other appliances and units.
- Do not put the appliance on a base.

### Electrical connection

- The appliance must be earthed.
- Make sure that the electrical data on the rating plate agree with your domestic power supply.
- Information on the voltage is on the rating plate.
- You must have the correct isolation devices: line protecting cut-outs, fuses (screw type fuses removed from the holder), earth leakage trips and contactors.

- The electrical installation must have an isolation device which lets you disconnect the appliance from the mains at all poles. The isolation device must have a contact opening width of minimum 3 mm.
- The shock protection parts must be fixed in such a way that they cannot be undone without tools.
- Always use a correctly installed shockproof socket.
- When you connect electrical appliances to mains sockets, do not let cables touch or come near the hot appliance door.
- Do not use multi-way plugs, connectors and extension cables. There is a risk of fire.
- Make sure not to squash or cause damage to the mains plug (if applicable) and cable behind the appliance.
- Make sure that the mains connection is accessible after the installation.
- Do not pull the mains cable to disconnect the appliance. Always pull the mains plug (if applicable).
- Do not replace or change the mains cable. Contact the service centre.

### Gas connection

- Make sure that airflow around the appliance is good. A defective air supply can cause lack of oxygen.
- Information about the gas supply is on the rating plate.
- This appliance is not connected to a combustion products evacuation device. It must be installed and connected in accordance with current installation regulations. Particular attention must be given to the relevant requirements regarding ventilation.
- The use of a gas cooking appliance cause heat and moisture in the room in which it is installed. Make sure that ventilation in the kitchen is good: keep natural ventilation holes open or install a mechanical ventilation device (mechanical extractor hood).
- More ventilation (for example opening of a window or increasing the level of mechanical ventilation where present) is necessary when you operate the appliance intensively for a long time .

### Use

- Only use the appliance for domestic cooking tasks. Do not use the appliance for commercial and industrial use. This is to prevent physical injury to persons or prevent damage to property.
- Always monitor the appliance during operation.

- Always stay away from the appliance when you open the door while the appliance is in operation. Hot steam can release. There is a risk of burns.
- Do not use this appliance if it is in contact with water. Do not operate the appliance with wet hands.
- Do not use the appliance as a work surface or storage surface.
- The cooking surface of the appliance becomes hot during use. There is a risk of burns. Do not put metallic objects, for example cutlery or saucepans lids, on the surface, as they can become hot.
- The interior of the appliance becomes hot during use. There is a risk of burns. Use gloves when you insert or remove the accessories or pots.
- Open the door carefully. The use of ingredients with alcohol can cause a mixture of alcohol and air. There is the risk of fire.
- Do not let sparks or open flames come near the appliance when you open the door.
- Do not put flammable products or items that are wet with flammable products, and/or fusible objects (made of plastic or aluminium) in, near or on the appliance. There is a risk of explosion or fire.
- Set the cooking zones to "off" after each use.
- Do not use the cooking zones with empty cookware or without cookware
- Do not let cookware boil dry. This can cause damage to the cookware and hob surface.
- If an object or cookware falls on the hob surface, the surface can be damaged.
- Do not put hot cookware near to the control panel because the heat can cause a damage to the appliance.
- Be careful when you remove or install the accessories to prevent damage to the appliance enamel.
- Cookware made of cast iron, cast aluminium or with damaged bottoms can scratch the hob surface if you move them on the surface.
- Discoloration of the enamel has no effect on the performance of the appliance.
- To prevent damage or discoloration to the enamel:
  - do not put any objects directly on the appliance floor and do not cover it with aluminium foil;
  - do not put hot water directly into the appliance;
  - do not keep moist dishes and food in the appliance after you finish the cooking.

- Do not apply pressure on the open door.
- Do not put flammable materials in the compartment below the oven. Keep there only heat-resistant accessories (if applicable).
- Do not cover oven steam outlets. They are at the rear side of the top surface (if applicable).
- This appliance is for cooking purposes only. It must not be used for other purposes, for example room heating.
- Use only stable cookware with the correct shape and diameter to prevent accidental tilting or spilling. There is a risk of burns.
- Do not use the appliance during a power cut.

## Lid

- The lid protects the appliance from dust when closed and collects splashes of grease when opened. Do not use it for other functions.
- Keep the lid clean all the time.
- Make sure that the appliance is cold before you close the lid.
- Glass lids can shatter when hot.

## Care and cleaning

- Before maintenance, make sure that the appliance is cold. There is a risk of burns. There is a risk that the glass panels can break.
- Keep the appliance clean at all times. A build-up of fats or other foodstuff can result in a fire.
- Regular cleaning prevents the surface material from deteriorating.
- For your personal safety and the safety of your property, only clean the appliance with water and soap. Do not use flammable products or products that can cause corrosion.
- Do not clean the appliance with steam cleaners, high-pressure cleaners, sharp objects, abrasive cleaning agents, abrasive sponges and stain removers.

- If you use an oven spray, follow the instructions from the manufacturer. Do not spray anything on the heating elements and the thermostat sensor.
- Do not clean the glass door with abrasive cleaning agents or metal scraper. Heat resistant surface of the inner glass can break and shatter.
- When the door glass panels are damaged they become weak and can break. You must replace them. Contact the service centre.
- Be careful when you remove the door from the appliance. The door is heavy.
- Bulb lamps used in this appliance are special lamps selected for household appliances use only. They cannot be used for the full or partial illumination of a household room.
- If it becomes necessary to replace the lamp use one of the same power and specifically designed for household appliances only.
- Disconnect the appliance from the power supply before the replacement of the oven lamp. There is the risk of electrical shock. Cool down the appliance. There is a risk of burns.
- Do not clean catalytic enamel.

## Service centre

- Only an approved engineer can repair or work on the appliance. Contact an approved service centre.
- Use only original spare parts.

## Disposal of the appliance

- To prevent the risk of physical injury or damage:
  - Disconnect the appliance from the power supply.
  - Cut off the mains cable and discard it.
  - Discard the door catch. This prevents children or small animals from being closed inside of the appliance. There is a risk of suffocation.

# Product description

---

## General overview

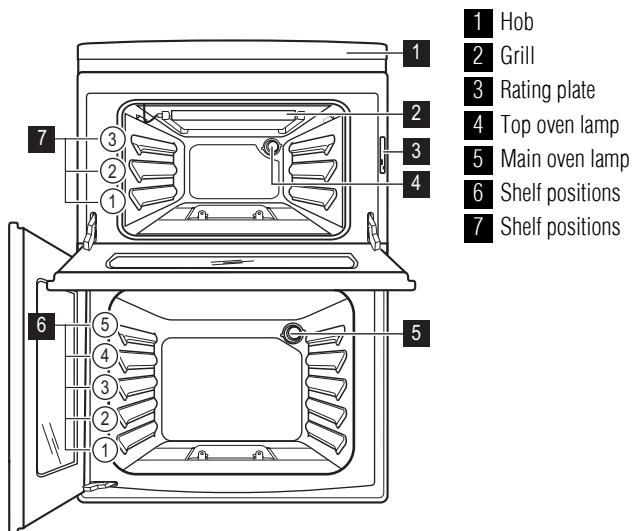

## Cooking surface layout

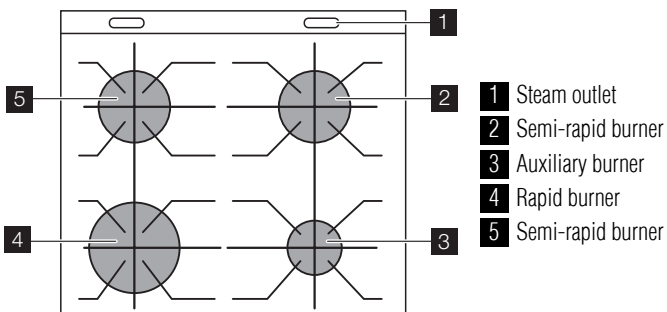

## Control panel

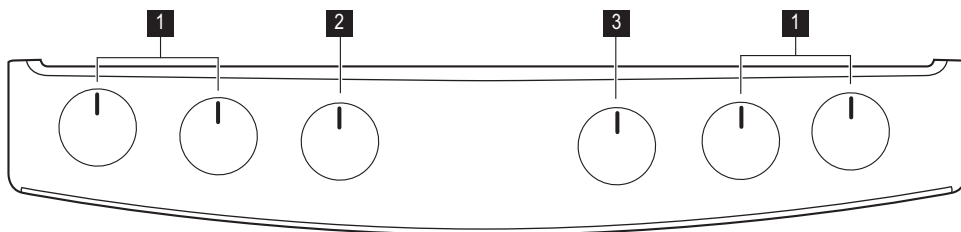

- 1** Hob control knobs
- 2** Main oven temperature control
- 3** Top oven / Grill control

### Accessories

- Oven shelf

## Before first use

**Warning!** Refer to "Safety information" chapter.

**i** Remove all packaging, both inside and outside the oven, before using the appliance. Do not remove the rating plate.

### Initial Cleaning

- Remove all parts from the appliance.
- Clean the appliance before first use.

**Warning!** Do not use abrasive cleaning agents! This can damage the surface. Refer to chapter "Care and Cleaning".

## Hob - Daily Use

**Warning!** Refer to "Safety information" chapter.

### Ignition of the burner

**Warning!** Be very careful when you use open fire in kitchen environment. Manufacturer decline any responsibility in case misuse of the flame

**i** Always light the burner before you put cookware.

To light the burner:

1. Turn the control knob counterclockwise to the maximum position ( ☆⬆ ) and push it down.

For cookware, cake tins, roasts.

- **Deep roasting pan**  
To bake and roast or as pan to collect fat.
- **The roasting pan grid**  
To put in the deep roasting pan.

### Preheating

Set an oven to maximum temperature and run an empty oven for 1 hour, to burn off any residue from the cavity surface. Accessories can become hotter than in normal use. During this period an odour can be emitted. This is normal. Make sure the room is well ventilated.

2. Keep the control knob pushed for approximately 5 seconds; this will let thermocouple to warm up. If not, the gas supply will be interrupted.
3. Adjust the flame after it is regular.

**i** If after some tries the burner does not light, check if the crown and its cap are in correct positions.

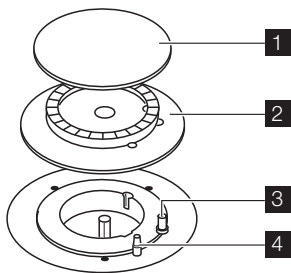

- 1** Burner cap
- 2** Burner crown
- 3** Thermocouple
- 4** Ignition candle

**Warning!** Do not keep control knob pressed for more than 15 seconds.

If the burner does not light after 15 seconds, release the control knob, turn it into off position and wait for at least 1 minute before trying to light the burner again.

### Turning the burner off

To put the flame out, turn the knob to the symbol **O**.

**Warning!** Always turn the flame down or switch it off before you remove the pans of the burner.

### Lid Safety Device

Lid has safety device, which cut off gas supply for hob. It works only when lid is closed.

**Warning!** Always use the control knob to switch off a burner. Do not use the lid as a cut-off device.

## Hob - Helpful hints and tips

### Energy savings

- If possible, always put the lids on the pans.
- When the liquid starts to boil, turn down the flame to barely simmer the liquid.

 Use pots and pans with bottom applicable to the dimension of burner.

Burner	Diameters of cookware
Rapid	180 mm - 260 mm

Burner	Diameters of cookware
Semi-rapid	120 mm - 220 mm
Auxiliary	80 mm - 160 mm

Use cookware with the bottom as thick and flat as possible.

## Hob - Care and Cleaning

**Warning!** Refer to "Safety information" chapter.

**Warning!** Switch the appliance off and let it cool down before you clean it.

**Warning!** For safety reasons, do not clean the appliance with steam cleaners or high-pressure cleaners.

**Warning!** Do not use abrasive cleaners, steel wool pads or acids, they can cause damage to the appliance.

- To clean the enamelled parts, cap and crown, wash it with warm soapy water.

- Stainless steel parts wash with water, and then dry with a soft cloth.
- The pan supports **are not** dishwasher proof; they must be washed **by hand**.
- Make sure you position the pan supports correctly after cleaning.
- To make burners work correctly, make sure that the arms of the pan supports are in the centre of the burner.
- **Be very careful when you replace the pan supports to prevent the hob top from damage.**

After cleaning, dry the appliance with a soft cloth.

# Oven - Daily Use

 **Warning!** Refer to "Safety information" chapter.

## Cooling fan



When the appliance operates, the cooling fan switches on automatically to keep the surfaces of the appliance cool. If you switch off the appliance, the cooling fan continues to operate until the appliance cools down.

## Switching the top oven, top oven grill or the main oven on and off

### Ignition of top oven gas burner:

Push the gas oven control knob and turn it to . Keep it pushed for some seconds, but no more than 15 seconds. Do not release it until the flame comes on.

### Ignition of top oven grill burner:

Push the gas oven control knob and turn it to  . Keep it pushed for some seconds, but no more than 15 seconds. Do not release it until the flame comes on.

 If the top oven gas burner or grill burner does not come on or if it accidentally goes out:

1. Release the gas oven control knob and turn it to the "Off" position.
2. Open the oven door.
3. After one minute, try to light the oven gas burner again.

 You cannot operate the top oven, when the grill is in use.

### Ignition of main oven gas burner:

Turn the gas oven control knob to .

 If the oven gas burner does not come on or if it accidentally goes out:

1. Turn the gas oven control knob to the "Off" position.
2. Open the oven door.
3. After one minute, try to light the oven gas burner again.

### After ignition:

1. Release the gas oven control knob.
2. Close the oven door.
3. Turn the gas oven control knob to the necessary temperature setting.

### Ovens safety device:

The top oven has a thermocouple. It stops the gas flow, if the flame goes out.



The main oven has a FSD system.

### Automatic ignition

Sometimes when oven is in operation you can hear noises, these are normal and do not refer to any defects. The main oven has an automatic ignition system which ignites again the burner if the flame accidentally goes out.

### Top Oven Functions

The oven has these functions:

Oven function		Application
	Off position	The appliance is off.
Gas mark 1 - 8	Range of temperature adjustment	Range of temperature adjustment for conventional cooking. To set temperature turn the knob counterclockwise.
	Grill	To grill flat food in the middle of the grill and to toast. To set grill turn the knob clockwise.

## Main Oven Functions

The oven has these functions:

Oven function		Application
	Off position	The appliance is off.



Oven function		Application
Gas mark 1 - 9	Range of temperature adjustment	Range of temperature adjustment for conventional cooking.
↓°C	Slow Cook	To prepare very lean, tender roasted food.

## Installing the oven accessories

Put the slide-in accessories between the guide bars of one of the oven levels.

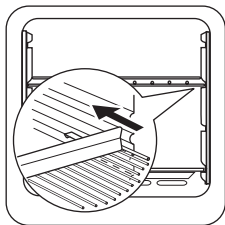

**Important!** The flame protection on the shelf must point up.

**i** Use the shelf with flame protection only on the first and second level in the top oven, and on all the levels in the main oven.

## Grilling set

The grilling set includes the roasting pan grid and the deep roasting pan. You can use the roasting pan grid on the two sides.

**Warning!** Risk of burns when removing the accessories from a hot oven.

You can use the grilling set to roast larger pieces of meat or poultry on one level:

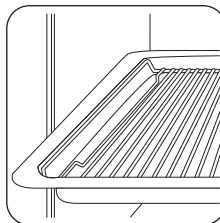

Put the roasting pan grid inside the deep roasting pan so that the supports of the oven shelf point upwards.

You can use the grilling set to grill flat dishes in large quantities and to toast:

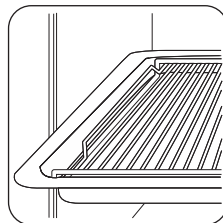

Put the roasting pan grid inside the deep roasting pan so that the supports of the oven shelf point downwards.

Put the deep roasting pan in the oven at the necessary level.

**i** Only put the grilling set on the second or third shelf level of top oven.

## Oven - Helpful hints and tips

**i** The temperature and baking times in the tables are guidelines only. They depend on the recipes, quality and quantity of the ingredients used.

## Information on acrylamides

**Important!** According to the newest scientific knowledge, if you brown food (specially the one which contains starch), acrylamides can pose a health risk. Thus, we recommend that you cook at the lowest temperatures and do not brown food too much.

## Top oven

The top oven is the smaller of the two ovens. It has 3 shelf levels. Use it to cook smaller quantities of food. It gives especially good results when used to cook fruitcakes, sweets and savoury flants or quiche.

## Main oven

The main oven is particularly suitable for cooking larger quantities of food.

## Baking

### General instructions

- Your new oven may bake or roast differently to the appliance you had before. Adapt your usual settings (temperature, cooking times) and shelf levels to the values in the tables.
- With longer baking times, the oven can be switched off about 10 minutes before the end of baking time, to use the residual heat.
- Use deep roasting pan in middle or top shelf level of top oven.
- To brown pastry dishes on the bottom, cook on metal plate or put on a baking tray.

**When you use frozen food, the trays in the oven can twist during baking. When the trays get cold again, the distortion will be gone.**

### How to use the Baking Tables

- We recommend to use the lower temperature the first time.
- If you cannot find the settings for a special recipe, look for the one that is almost the same.
- Baking time can be extended by 10-15 minutes, if you bake cakes on more than one level.
- Cakes and pastries at different heights do not always brown equally at first. If this occurs, do not change the temperature setting. The differences equalize during the baking procedure.

### Tips on baking

Baking results	Possible cause	Remedy
The cake is not browned sufficiently below	Incorrect oven level	Put the cake on a lower oven level
The cake sinks (becomes soggy, lumpy, streaky)	Oven temperature too high	Use a lower setting
The cake sinks (becomes soggy, lumpy, streaky)	Baking time is too short	Set a longer baking time <b>Do not set higher temperatures to decrease baking times</b>
The cake sinks (becomes soggy, lumpy, streaky)	Too much liquid in the mixture	Use less liquid. Look at the mixing times, specially when you use mixing machines
Cake is too dry	Oven temperature too low	Set a higher oven temperature
Cake is too dry	Baking time too long	Set a shorter baking time
Cake does not brown equally	Oven temperature too high and baking time too short	Set a lower oven temperature and a longer baking time
Cake does not brown equally	No equal mixture	Put the mixture equally on the baking tray
Cake does not cook in the baking time set	Temperature too low	Use a slightly higher oven temperature setting

### Top oven cooking chart

Food	Shelf position	Gas mark	Cooking Time (Total Hours)
Biscuits	1-2	4	0:10 - 0:20

Food	Shelf position	Gas mark	Cooking Time (Total Hours)
Small / Queen Cake	1-2	5	0:18 - 0:25
Sponge	1-2	4	0:18 - 0:20
Victoria Sandwich	1-2	4	0:18 - 0:25
Gingerbread	1-2	2	1:15 - 1:30
Meringues	1-2	1	2:30 - 3:00
Flapjack	1-2	5	0:25 - 0:30
Shortbread	1-2	3	0:45 - 1:05
Fruit Pies, Crumbles	1-2	6	0:40 - 0:50
Milk Puddings	1-2	3	1:30 - 2:00
Scones	1-2	7	0:08 - 0:12
Choux Pastry	1-2	6	0:30 - 0:35
Éclairs / Profiteroles	1-2	5	0:20 - 0:30
Flaky Pastry	1-2	6	0:25 - 0:40
Mince Pies	1-2	5	0:15 - 0:20
Pasta Lasagne etc.	1-2	5	0:40 - 0:45
Meat Pies	1-2	7	0:25 - 0:35
Quiche, Tarts, Flans	1-2	5	0:25 - 0:45
Shepherd's Pie	1-2	7	0:30 - 0:40
Soufflés	1-2	5	0:20 - 0:30
Fish	1-2	4	0:20 - 0:30
Fish Pie	1-2	6	0:20 - 0:25
Beef Casserole	1-2	3	2:30 - 3:00
Lamb Casserole	1-2	4	2:30 - 3:00
Convenience Foods	Follow manufacturer's instructions		
Baked Potatoes	1-2	5	1:00 - 1:30
Roast Potatoes	1-2	6	1:00 - 1:30
Large Yorkshire Puddings	1-2	7	0:25 - 0:40
Individual Yorkshire Puddings	1-2	7	0:15 - 0:25

### Main oven cooking chart

Food	Shelf position	Gas mark	Cooking Time (Total Hours)
Biscuits	1+4	4	0:10 - 0:20

Food	Shelf position	Gas mark	Cooking Time (Total Hours)
Bread	2-3	g <sup>1</sup> )	0:25 - 0:30
Bread rolls/buns	3-4	g <sup>1</sup> )	0:15 - 0:20
Small / Queen Cake	1+4	5	0:18 - 0:25
Sponge	1+4	4	0:20 - 0:30
Victoria Sandwich	1+4	4	0:18 - 0:25
Madeira Cake	2-3	4	1:15 - 1:30
Rich Fruit Cake	2-3	2	2:15 - 2:30
Christmas Cake	2-3	2	3:00 - 4:30
Gingerbread	2-3	2	1:15 - 1:30
Meringues	3-4	1	2:30 - 3:00
Flapjack	3	5	0:25 - 0:30
Shortbread	3	3	0:45 - 1:05
Fruit Pies, Crumbles	3	6	0:40 - 0:60
Milk Puddings	3	3	1:30 - 2:00
Scones	1+4	7	0:08 - 0:12
Choux Pastry	3	6	0:30 - 0:35
Éclairs / Profiteroles	3	5	0:20 - 0:30
Flaky Pastry	3	6	0:25 - 0:40
Mince Pies	1+4	5	0:15 - 0:20
Pasta Lasagne etc.	3	5	0:40 - 0:45
Meat Pies	3	2	0:25 - 0:35
Quiche, Tarts, Flans	3	2	0:25 - 0:45
Shepherd's Pie	3	7	0:30 - 0:40
Soufflés	3	5	0:20 - 0:30
Fish	3	4	0:20 - 0:30
Fish Pie	3	6	0:20 - 0:25
Beef Casserole	2	3	2:30 - 3:00
Lamb Casserole	2	4	2:30 - 3:00
Convenience Foods	Follow manufacturer's instructions		
Baked Potatoes	3-4	5	1:00 - 1:30
Roast Potatoes	3-4	6	1:00 - 1:30
Large Yorkshire Puddings	3-4	7	0:25 - 0:40

Food	Shelf position	Gas mark	Cooking Time (Total Hours)
Individual Yorkshire Puddings	3-4	7	0:15 - 0:25

1) When baking bread cook for 10 minutes at gas mark 8 then reduce to mark 6 for the remaining cook time.

## Roasting

### Roasting dishes

- Use heat-resistant ovenware to roast (please read the instructions of the manufacturer).
- Large roasting joints can be roasted directly in the deep roasting pan or on the oven shelf above the deep roasting pan. (If present)
- Roast lean meats in a roasting tin with a lid. This will keep the meat more succulent.

- All types of meat, that can be browned or have crackling, can be roasted in the roasting tin without the lid.
- Use deep roasting pan in middle or top shelf level of top oven and in two or higher level of main oven.
- **Make sure that the grilling set or roasting pan is set in middle of shelf between front and rear of the oven cavity**

### Roasting chart

Meat	Shelf Level	Gas Mark	Cooking time
Beef/ Beef boned	2	5	20-35 minutes per 500g (1lb) and 20-35 minutes over
Mutton/Lamb	2	5	25-35 minutes per 500g (1lb) and 25-35 minutes over
Pork/Veal/Ham	2	5	30-40 minutes per 500g (1lb)
Chicken	2	5	15-20 minutes per 500g (1lb) and 20 minutes over
Turkey/Goose	2	5	15-20 minutes per 500g (1lb) up to 3500g (7lb) then 10 minutes per 500g (1lb) over 3500g (7lb)
Duck	2	5	25-35 minutes per 500g (1lb) and 25-30 minutes over
Pheasant	2	5	35-40 minutes per 500g (1lb) and 35-40 minutes over
Rabbit	2	5	20 minutes per 500g (1lb) and 20 minutes over

## Grilling

**Always use the grilling function with maximum temperature setting**

### Warning!

- When grill operates, closing the door automatically cut-off the flames.
- Do not use the door as a cut-off device.

- Always grill with the oven door opened.
- Keep minimum 5 cm distance from front and rear edges of grilling area.
- Do not put a meal on edge of shelf.
- The grilling area is set in centre of the shelf.

- **Make sure that the grilling set or roasting pan is set in middle of shelf between front and rear of the oven cavity**



**Caution!** Accessible parts may be hot when grill is in use. Young children should be kept away.



Always pre-heat the empty oven with the grill functions for 5 minutes.

- Set the shelf in the shelf level as recommended in the grilling table.
- When use grilling set in top oven, always remove the oven shelf.
- Grill only flat pieces of meat or fish.

## Grilling chart

Food	Shelf position	Grilling Time (Total Hours)
Bacon Rashers	2-3	0:05 - 0:06
Beef Burgers (home-made)	2-3	0:20 - 0:30
Chicken Joints	2-3	0:30 - 0:40
Lamb Chops	2-3	0:15 - 0:20
Pork Chops	2-3	0:20 - 0:30
Whole Trout/Mackerel	2-3	0:15 - 0:25
Plaice/Cod Fillets	2-3	0:10 - 0:15
Kebabs	2-3	0:20 - 0:30
Kidneys – Lamb/Pig	2-3	0:08 - 0:12
Liver – Lamb/Pig	2-3	0:10 - 0:20
Sausages	2-3	0:20 - 0:30
Steak – Rare	2-3	0:06 - 0:12
Steak – Medium	2-3	0:12 - 0:16
Steak – Well Done	2-3	0:14 - 0:20
Toasted Sandwiches	2-3	0:01 - 0:03

## Slow Cook

Use the function to prepare soups stews, casseroles or lean, tender pieces of meat and fish.

You have to cook food at gas mark 6 for 30 minutes before you turn the oven down to the slow cook setting. This is to make sure that the temperature of the food gets hot sufficient to start the food cooking process.

1. Fully open the door before you light the main oven.
2. Push in the control knob and turn it to gas mark 9.
3. When the flames come on, release the control knob. Only small flames come on at first.
4. Turn the main oven control knob to gas mark 6.
5. When the large flames come on, put your food in the appliance and close the door.



**Caution!** Do not close the door until the large flames come on.

6. After 20 minutes turn the main oven control knob to the slow cook setting.
7. To turn the slow cook off, turn the control knob to the off position **O**.



Cook all food with a lid when you use the Slow Cook function. You can remove the lid in the last 30 minutes if it has usually golden brown effect.



You cannot use Slow Cook together with the clock functions: Duration and End.

## Slow Cook - use

**General points :**

## Frozen Foods

- Fully thaw the food before cooking.

## Thickening

- Cover the meat with the flour for casseroles or mix the cornflour with the water and add it at the end of cooking

## Flavouring

- Flavours are held in the food because there is small evaporation. Adjust flavouring at the end of the cooking time.

## Liquid

- Use less liquid as there is small evaporation during cooking. Always add milk and milk products, for example cream to the end of cooking to prevent them from curdling.

## Reheating

-  Do not reheat food with the slow cook setting.

### Joints of meat and poultry

- Do not cook meat joints which are more than 2,7kg (6lb).
- Do not cook poultry which is more than 2 kg (4lb eight oz).
- Cook on or above the middle shelf of the oven.

## Oven - Care and Cleaning

 **Warning!** Refer to "Safety information" chapter.

 **Warning!** Before you clean the appliance, switch it off. Make sure that the appliance is cold.

 **Warning!** Do not clean the appliance with steam cleaners or high-pressure cleaners.

 **Caution!** Do not use corrosive or scouring cleaning agents, sharp objects, stain removers or abrasive sponges.

 **Warning!** Do not clean the glass door with abrasive cleaning agents or metal scraper. Heat resistant surface of the inner glass can damage.

 **Caution!** If you use an oven spray, follow the instructions from the manufacturer.

- Clean the front of the appliance with a soft cloth with warm water and cleaning agent.
- To clean metal surfaces use a usual cleaning agent

- Cook the stuffing separately.
- Cook for minimum six hours.
- Only cook joints of pork if the temperature inside the joint is minimum 88°C. Use a meat thermometer to examine the temperature.
- For good air circulation always put the joints on a rack in a roasting tin or casserole.
- Thaw all frozen meat and poultry before you cook it.
- Remove unwanted fat and skin unless it is browned first.

## Soups, casseroles and stews

- Do not cook casseroles which are more than 2,7 (6lb).
- Let the dish boil on the hob and then cook it on the slow cook setting.
- Cook on or above the middle shelf of the oven.
- Use a lid or tin foil when you use slow cook setting.
- 

## Vegetables

- Cut the vegetables in small pieces.
- Before you add dried beans to a dish, soak the beans first and boil in an open pan for 15 minutes. .
- Put the vegetables below the meat in casseroles.
- Use a lid or tin foil when you use slow cook setting.

- Clean the oven interior after each use. Thus you can remove dirt more easily and it does not burn on.
- Clean stubborn dirt with a special oven cleaner.
- Clean all oven accessories (with a soft cloth with warm water and cleaning agent) after each use and let them dry.
- If you have nonstick accessories, do not clean them using an aggressive agents, sharp edged objects or dishwasher. It can destroy nonstick coating!

### **Stainless steel or aluminium appliances:**

Clean the oven door with a wet sponge only. Dry it with a soft cloth.

Do not use steel wool, acids or abrasive materials as they can damage the oven surface. Clean the oven control panel with the same precautions

## Cleaning the top oven glass panels

**i** The door glass on your product can be different in type and shape from what you see in diagrams. The number of glasses can be different.

### Removing the glass:

1. Open the door.
2. Push the door trim at both sides to release the clips. Refer to the picture.
3. Remove the glass panels.

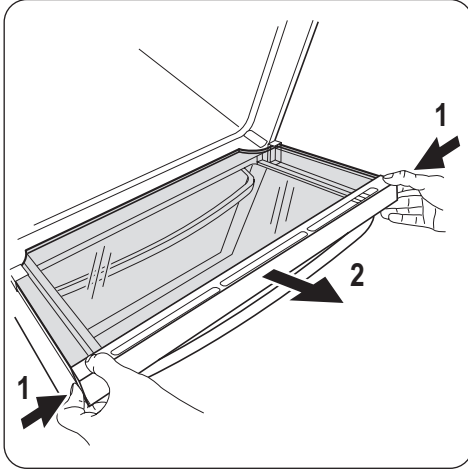

**i** To replace the glass obey the procedure in opposite sequence.

## Cleaning the oven door

**i** The door glass on your product can be different in type and shape from what you see in diagrams. The number of glasses can be different.

### Removing the glass:

1. Push the door trim at one side to remove it. Refer to the picture.
2. Pull up the trim.

## What to do if...

3. Remove the glass panels.

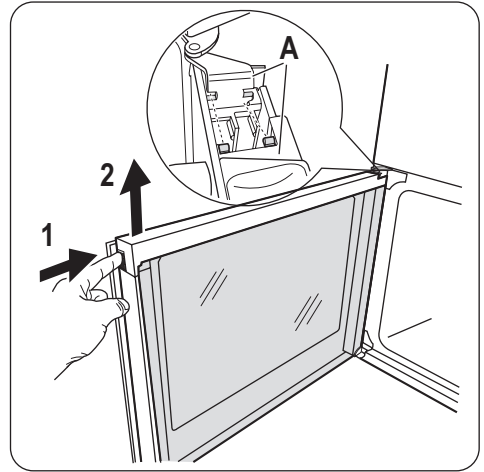

**i** To replace the glass panels obey the procedure in opposite sequence. Before you lower the trim attach the A trim part to the door. Refer to picture.

## Oven lamp

**!** **Warning!** There is a danger of electrical shock!

### Before you change the oven lamp:

- Switch off the oven.
- Remove the fuses in the fuse box or switch off the circuit breaker.

**i** Put a cloth on the bottom of the oven for protection of the oven light and glass cover.

Replacing the oven light bulb/cleaning the glass cover

1. Turn the glass cover anti-clockwise to remove it.
2. Clean the glass cover.
3. Replace the oven light bulb with applicable 300°C heat-resistant oven light bulb.
4. Install the glass cover.

Problem	Possible cause	Remedy
The appliance does not operate.	The fuse in the fuse box is released.	Control the fuse. If the fuse is released more than one time, refer to a qualified electrician.



Problem	Possible cause	Remedy
The appliance does not operate.	The appliance is too hot.	Cool down the appliance for some hours.
The grill, burners, ovens do not work.	There is no electrical supply.	Make sure that the unit is connected and the electrical supply is switched on.
The grill, burners, ovens do not work.	There is no electrical supply.	Examine the house electrical installation fuse.
The grill, burners, ovens do not work.	There is no gas supply.	Examine the house gas supply, use other gas appliance (Central heating or gas fires).
There is no spark when lighting the gas.	Burner cap and crown are placed uneven.	Make sure that the burner cap and crown are in correct positions.
The flame is blow out immediately after ignition.	Thermocouple is not heated sufficient.	After lightning the flame, keep the knob pushed for approximately 5 seconds.
The gas ring burns unevenly.	The burner crown is blocked with food residue.	Make sure that the injector is not blocked and the burner crown is clear of food particles or cleaning fluids. Dry them with a cloth and clean stubborn marks away with a dry nylon brush (for example an old toothbrush).
The oven does not heat up.	The oven is not switched on.	Switch on the oven.
The oven does not heat up.	The necessary settings are not set.	Control the settings.
The oven does not cook evenly.		Check that the appliance is correctly installed and levelled, and that you use the recommended temperatures and shelf positions.
The oven lamp does not operate.	The oven lamp is defective.	Replace the oven lamp.
Steam and condensation settle on the food and in the oven cavity.	You left the dish in the oven for too long.	Do not leave the dishes in the oven for longer than 15-20 minutes after the cooking process ends.
The appliance makes noises or popping sounds.		When the gas is drawn through the burner, it can compress as they heat up. Some metal parts of the appliance expand and contract when they heat up or cool down. The noises are normal.

Problem	Possible cause	Remedy
The flame colour is orange or yellow.		The flame can look orange or yellow (flame disturbance) in some areas of the burner because of how the burner is made. This is normal.

If you cannot find a solution to the problem yourself, contact your dealer or the service centre.

The necessary data for the service centre is on the rating plate. The rating plate is on the front frame of the oven cavity.

We recommend that you write the data here:

Model (MOD.)

.....

Product number (PNC)

.....

Serial number (S.N.)

.....

## Installation

**Warning!** Refer to "Safety information" chapter.

### Technical Data

Dimensions	
Height	900 mm
Width	595 mm
Depth	600 mm
Top oven capacity	33 l
Main oven capacity	77 l

### Location of the appliance

You can fit your freestanding appliance with cabinets on one or both sides and in the corner.

Do not install the appliance in a bed-sitting room of volume less than 20 m<sup>3</sup> or in a bathroom, shower room or garage.

**Warning!** Do not install the appliance below ground level, for example in a basement, or aboard a boat, yacht or other vessel.

For the minimal distances of fitting check the table.

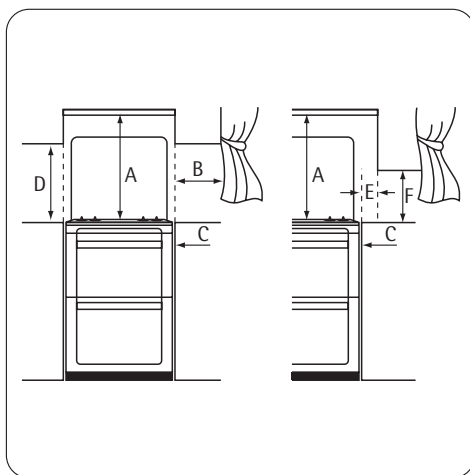

### Minimal distances

Dimension	mm
A	650
B	150
C	2
D	400
E	450

Dimension	mm
F	less than 400

**Warning!** Do not set the appliance on a base

### Levelling

Use small feet on the bottom of appliance to set same level of cooker top surface with other surfaces

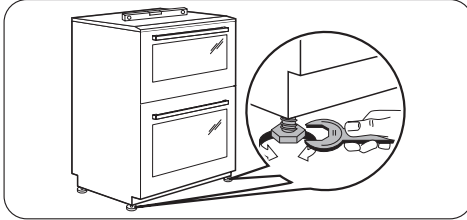

### The stability chain

**Caution!** You must install the stability chain. If you do not install it the appliance can tilt.

Before you install stability chain, adjust the appliance to the correct height.

Measure down 180 mm from the appliance top surface, then measure right 30 mm (See picture). Mark the position of the wall and this gives anchor point for the stability chain.

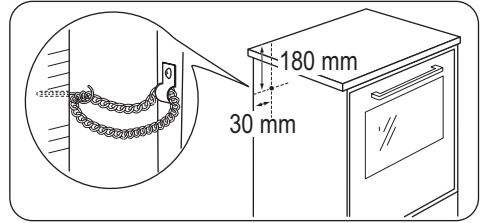

**Warning!** These instructions are only valid in the countries whose symbols appear on this booklet's cover.

Gas Category	I2H
Gas Supply	G20 - 20 mbar

## Gas burners

BURNER	NORMAL POWER kW	NATURAL GAS	
		inj. 100/mm	Btu/h
Auxiliary burner	1,0	70	3412
Semi-rapid burner	1,9	96	6483
Rapid burner	3,0	119	10236
Grill	2,7	120	9212
Top Oven	1,9	99	6483
Main Oven	1,9	99	6483

### Gas Connection

Use a flexible pipe in compliance with the regulation in force. Be careful they do not come in touch with mobile parts or they are not squeezed.

**Warning!** Only a qualified and competent person must do the gas installation.

**Warning!** Before gas connection disconnect the mains plug from the mains socket or switch off the fuse in the fuse box. Close the primary valve of the gas supply.

**i** Supply piping should not be less than R3/8. Connection is made to the Rc 1/2 (1/2 " B.S.P.) female threaded. Entry pipe located just below the hob level on the rear left hand side of the appliance. The gas supply ramp is on the rear side of the appliance.

**Warning!** Only liquid sealants to be used when inlet gas pipe is fitted i.e.: do not use P.T.F.E. sealant tape.

When installation is complete. Carry out a gas tightness test and make sure that the seal of each pipe fitting is correct.

**Important!** Use flexible tubing, which comply with BS.669 current edition.

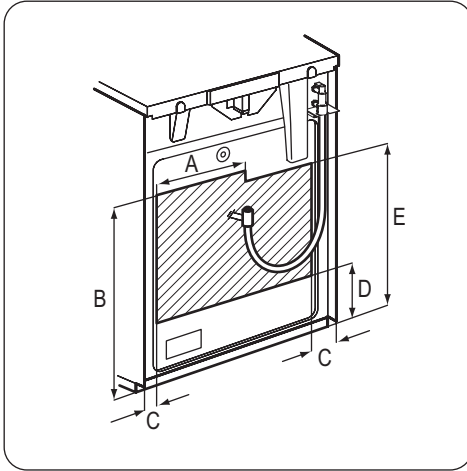

**Warning!** The gas bayonet must be in mark area.

Dimension	mm
A	250
B	680
C	50
D	250
E	580

### Pressure test

The Rapid injector is used as a pressure test point.

1. Connect the pressure gauge to the Rapid injector.
2. Examine the supply pressure by turning the Rapid burner and one other burner fully on, and lighting them. The pressure must be:
  - a) 20 mbar for Natural Gas
  - b) 29 mbar for LPG, butane only
  - c) 37 mbar for LPG, propane only.
3. Turn the taps off and disconnect the pressure gauge.

4. Make sure that all burners work correctly.

### Checking the grill

1. Put in the grill pan containing the grid.
2. Light the grill burner by turning the grill control knob to the symbol .
3. Release the knob when the burner comes on.



### Checking the hob burners

1. Lift the lid.
2. Put in the burner crowns and caps. Make sure that they are correctly seated.
3. Put in the pan supports.
4. Check each of the burners in turn by turning the burner control knob to the symbol .
5. Release the knob when the burners come on.

### Checking the lid shut-off device

1. Lift the lid.
2. Light one of the hob burners.
3. Close the lid. There should be no gas supply to the hob burners. The burner goes out.
4. Turn the burner off and lift the lid. The gas supply should be restored to the hob burners, when you turn the knob on.

### Checking the main oven

1. Turn the gas oven control knob to the symbol .
2. When the oven burner comes on, the gas at first flows to the oven burner slowly, at the FSD by-pass rate.
3. When the FSD heat sensor is heated sufficiently, it opens the FSD valve. The main gas stream flows to the burner.
4. After 1 minute make sure that the flame covers the full width of the burner and is stable.
5. Set the oven control knob to  and close the oven door. After about 10 minutes the flame size should decrease.
6. Turn the control knob off and check that the oven flames go out.

### Electrical installation

**Warning!** Only a qualified and competent person must do the electrical installation.

**i** The manufacturer is not responsible if you do not follow safety precautions from chapter "Safety information".

This appliance is supplied with a main plug and a main cable.

-  Connect the phases correctly, if you do not connect, spark generator will work all the time.

## Environment concerns

The symbol  on the product or on its packaging indicates that this product may not be treated as household waste. Instead it should be taken to the appropriate collection point for the recycling of electrical and electronic equipment. By ensuring this product is disposed of correctly, you will help prevent potential negative consequences for the environment and human health, which could otherwise be caused by inappropriate waste handling of this product. For more detailed information about recycling of this product, please contact your local council, your household waste disposal service or the shop where you purchased the product.

**MANUFACTURER:**  
ELECTROLUX POLAND Sp.z o.o..  
ul.Kazimierza Odnowiciela 28  
58-100 Świdnica - POLAND

 Packaging material  
The packaging material is environmentally-friendly and recyclable. Plastic parts are marked with international abbreviations such as PE, PS, etc. Dispose of the packaging material in the containers provided for this purpose at your local waste management facility.

 **Warning!** Your appliance should be made inoperable before it is disposed of, so that it does not constitute a danger.  
To do this, take the mains plug from the socket and remove the mains cable from the appliance.

## GREAT BRITAIN & IRELAND - Guarantee/Customer Service

### Standard guarantee conditions

We, Electrolux, undertake that if within 12 months of the date of the purchase this Electrolux appliance or any part thereof is proved to be defective by reason only of faulty workmanship or materials, we will, at our option repair or replace the same FREE OF CHARGE for labour, materials or carriage on condition that:

- Appliance has been correctly installed and used only on the electricity supply stated on the rating plate.
- Appliance has been used for normal domestic purposes only, in accordance with manufacturer's instructions.
- Appliance hasn't been serviced, maintained, repaired, taken apart or tampered with by person not authorised by us.
- Electrolux Service Force Centre must undertake all service work under this guarantee
- Any appliance or defective part replaced shall become the Company's property.
- This guarantee is in addition to your statutory and other legal rights.

### Exclusions

- Damage, calls resulting from transport, improper use, neglect, light bulbs, removable parts of glass, plastic.
- Costs for calls to put right appliance which is improperly installed, calls to appliances outside United Kingdom.
- Appliances found to be in use within a commercial environment, plus those which are subject to rental agreements.
- Products of Electrolux manufacturer that are not marketed by Electrolux

**Service and Spare Parts.** Please contact your local Service Force Centre: **08445 616 616** (Call will be routed to Service Force Centre covering your postcode area). For address of local Service Force Centre and further information, please visit: **[www.serviceforce.co.uk](http://www.serviceforce.co.uk)** Before calling out an engineer, please ensure you have read the details under the heading "What to do if...". When you contact the Service Force Centre you will need to give the following details: Your name, address and postcode, your telephone number, clear concise details of the fault, model and serial number of the appliance (found on the rating plate), the purchase date. Please note a valid purchase receipt or

guarantee documentation is required for in guarantee service calls.

**Customer Care.** Please contact our Customer Care Department: Electrolux Major Appliances, Addington Way, Luton, Bedfordshire, LU4 9QQ or visit our website at [www.electrolux.co.uk](http://www.electrolux.co.uk)

Customer Care Department,	Tel: (Calls may be recorded for training purposes)
Electrolux	08445 613 613
AEG-Electrolux	08445 611 611

**European Guarantee:** This appliance is guaranteed by Electrolux in each of the countries listed at the back of this user manual, for the period specified in the appliance guarantee or otherwise by law. If you move from one of these countries to another of the countries listed, the appliance guarantee will move with you subject to the following qualifications:-

- The appliance guarantee starts from the date you first purchased the appliance which will be evidenced by production of a valid purchase document issued by the seller of the appliance.
- The appliance guarantee is for the same period and to the same extent for labour and parts as exists in your new country of residence for this particular model or range of appliances.

Customer Care Department,	Tel: (Calls may be recorded for training purposes)
Zanussi-Electrolux	08445 612 612



**For Customer Service in The Republic of Ireland please contact us at the address below:**

Electrolux Group (Irl) Ltd, Long Mile Road, Dublin 12, Republic of Ireland  
Tel: +353 (0)1 4090751, Email: [service.eid@electrolux.ie](mailto:service.eid@electrolux.ie)

- The appliance guarantee is personal to the original purchaser of the appliance and cannot be transferred to another user.
- The appliance is installed and used in accordance with instructions issued by Electrolux and is only used within the home, i.e. is not used for commercial purposes.
- The appliance is installed in accordance with all relevant regulations in force within your new country of residence.

The provisions of this European Guarantee do not affect any of the rights granted to you by law.

[www.electrolux.com](http://www.electrolux.com)

		
Albania	+35 5 4 261 450	Rr. Pjeter Bogdani Nr. 7 Tirane
Belgique/België/Belgien	+32 2 363 04 44	Bergensesteenweg 719, 1502 Lembeek
Česká republika	+420 261302111	Budějovická 3, Praha 4, 140 21
Danmark	+45 70 11 74 00	Sjællandsgade 2, 7000 Fredericia
Deutschland	+49 180 32 26 622	Fürther Str. 246, 90429 Nürnberg
Eesti	+37 2 66 50 030	Pärnu mnt. 153, 11624 Tallinn
España	+34 902 11 63 88	Carretera M-300, Km. 29,900 Alcalá de Henares Madrid
France	08 44 62 26 53	<a href="http://www.electrolux.fr">www.electrolux.fr</a>

		
Great Britain	+44 8445 616 616	Addington Way, Luton, Bedfordshire LU4 9QQ
Hellas	+30 23 10 56 19 70	4, Limnou Str., 54627 Thessaloniki
<b>Hrvatska</b>	<b>+385 1 63 23 338</b>	<b>Slavonska avenija 3, 10000 Zagreb</b>
Ireland	+353 1 40 90 753	Long Mile Road Dublin 12
Italia	+39 (0) 434 558500	C.so Lino Zanussi, 26 - 33080 Porcia (PN)
<b>Latvija</b>	<b>+371 67313626</b>	<b>Kr. Barona iela 130/2, LV-1012, Riga</b>
<b>Lietuva</b>	<b>+370 5 278 06 03</b>	<b>Ozo 10a, LT-08200 Vilnius</b>
Luxembourg	+352 42 431 301	Rue de Bitbourg, 7, L-1273 Hamm
<b>Magyarország</b>	<b>+36 1 252 1773</b>	<b>H-1142 Budapest XIV, Erzsébet királyné útja 87</b>
Nederland	+31 17 24 68 300	Vennootsweg 1, 2404 CG - Alphen aan den Rijn
Norge	+47 81 5 30 222	Risløkkvn. 2 , 0508 Oslo
Österreich	+43 18 66 400	Herziggasse 9, 1230 Wien
<b>Polska</b>	<b>+48 22 43 47 300</b>	<b>ul. Kolejowa 5/7, Warszawa</b>
Portugal	+35 12 14 40 39 39	Quinta da Fonte - Edificio Gonçalves Zarco - Q 35 -2774-518 Paço de Arcos
<b>Romania</b>	<b>+40 21 451 20 30</b>	<b>Str. Garii Progresului 2, S4, 040671 RO</b>
Schweiz - Suisse - Svizzera	+41 62 88 99 111	Industriestrasse 10, CH-5506 Mägenwil
Slovenija	+38 61 24 25 731	Gerbičeva ulica 98, 1000 Ljubljana
Slovensko	+421 (02) 32141334	Electrolux Slovakia s.r.o., Electrolux Domáce spotrebiče SK, Seberínho 1, 821 03 Bratislava
Suomi	<a href="http://www.electrolux.fi">www.electrolux.fi</a>	
Sverige	+46 (0)771 76 76 76	Electrolux Service, S:t Göransgatan 143, S-105 45 Stockholm
Türkiye	+90 21 22 93 10 25	Tarlabaşı caddesi no : 35 Taksim İstanbul
Россия	+7 495 937 7837	129090 Москва, Олимпийский проспект, 16, БЦ "Олимпик"
Україна	+380 44 586 20 60	04074 Київ, вул.Автозаводська, 2а, БЦ "Алкон"



[www.zanussi.com/shop](http://www.zanussi.com/shop)

