

ZANUSSI

**Instructions
for the use and care
of GC 21 M cooker**

It is most important that this instruction book should be retained with the appliance for future reference. Should the appliance be sold or transferred to another owner, or should you move house and leave the appliance, always ensure that the book is supplied with the appliance in order that the new owner can be acquainted with the functioning of the appliance and the relevant warnings.

Warnings – Gas cookers

THESE WARNINGS ARE PROVIDED IN THE INTEREST OF SAFETY. YOU MUST READ THEM CAREFULLY BEFORE INSTALLING OR USING THE APPLIANCE.

- This appliance is designed to be operated by adults. Children should not be allowed to tamper with the controls or play with the product.
- Any installation work must be undertaken by a competent, qualified installer in accordance with the Gas Safety (Installation and Use) Regulations 1984 and the relevant codes of practice. In the U.K. C.O.R.G.I. registered installers (including regions of British Gas) undertake the work to safe and satisfactory standards.
- Any electrical work required to install this appliance should be carried out by a qualified electrician.
- It is dangerous to alter the specifications or modify the product in any way.
- Under no circumstances should any maintenance work be carried out by any other than a qualified person.
- This product should be serviced by an authorised Zanussi Network Service Centre, and only genuine Zanussi spare parts should be used.
- Unstable or misshapen pans should not be used on the burner as unstable pans can cause an accident by tipping or spillage.
- Cookers and hobs become very hot with use, and retain their heat for a long period of time after use. Children should be supervised at all times and should not be allowed to touch the hot surfaces or be in the vicinity when in use or until the appliance has cooled after use.
- If the appliance is fitted with a lid, this is designed as a dust cover when closed, and as a splash-back when open. Do not use for any other purposes.
- It is always necessary to remove any spillage from the surface of the cover before removal or opening (if applicable), and the appliance should be allowed to cool before replacing or closing the cover.
- This product should only be used with natural gas.
- Always ensure that the control knobs are in the «off» position when not in use.
- All gas appliances require adequate ventilation. Failure to provide this could result in a lack of oxygen. Your installer will advise if in doubt.
- For hygiene and safety reasons, this appliance should be kept clean at all times. A build-up of fats or other foodstuffs could result in a fire.
- This product has been designed for cooking edible foodstuffs only, and must not be used for any other purposes.
- Always ensure that the oven vent which is located at the centre back of the hob is left unobstructed to ensure ventilation of the oven cavity.
- A gas oven relies on the movement of air for heating. Under no circumstances should the vents in the base of the oven be obstructed. Never line any part of the oven with aluminium foil.
- Do not allow the oven cavity to fill with un-lighted gas.
- This appliance is heavy and care must be taken when moving it.
- Before any maintenance or cleaning always unplug the appliance from the electrical supply, and allow to cool.
- Before igniting the oven or grill, open the oven door.
- Ensure that oven anti-tip shelves are put in place in the correct way. (See instructions).
- Under no circumstances should gas cookers and hobs be left unattended when in use.
- Easy clean liners should never be cleaned with anything other than soapy water. (See instructions regarding cleaning).
- When operating a burner, the grill or oven, make sure that the gas is fully ignited.
- Only oven-proof dishes are to be stored in the drawer beneath the oven. Do not store combustible materials.
- Under no circumstances should you attempt to repair the appliance yourself. Repairs carried out by unauthorised or inexperienced persons may cause injury or more serious malfunctioning. Refer to your local Zanussi Network Service Centre. Always insist on genuine Zanussi spare parts.

Contents

Instructions for the owner

Installation	Page 3
Technical data	Page 3
Use	Page 4
Gas oven	Page 6
Analogue clock	Page 7
Using the rotisserie	Page 8
Oven cooking chart	Page 9
Maintenance & cleaning	Page 13

Instructions for the installer

Installation	Page 15
Electrical connection	Page 17
Gas connection	Page 18
Maintenance	Page 19

Caution:

Before you start operating the appliance, be sure to remove the plastic films protecting the stainless steel or anodized aluminium parts.

Important: During normal cooking operations the appliance will get very hot. Therefore, do not let children play near the appliance.

Instructions for the owner

Installation

It is mandatory that all operations required for the installation, the adjustments, the conversion to the type of gas available etc. be carried out by **QUALIFIED PERSONNEL** in accordance with existing rules and regulations.

The relevant instructions are to be found in the special chapter for the installer.

This appliance meets the requirements laid down in EEC Directive No. 82/499 dated 7/6/1982 relating to the suppression of radio and TV interference.

Technical data

Model	GC 21 M
Dimensions: height	900 mm
depth	598 mm
width	597 mm
Oven volume	53 dm ³
Automatic lighting: worktop	YES
oven and grill	YES
Safety (Thermocouple): oven and grill	YES
Roasting jack: multiple rotisserie	YES
Oven lamp	YES
Analogue clock	YES
Supply voltage (240V - 50Hz)	YES

Use and care

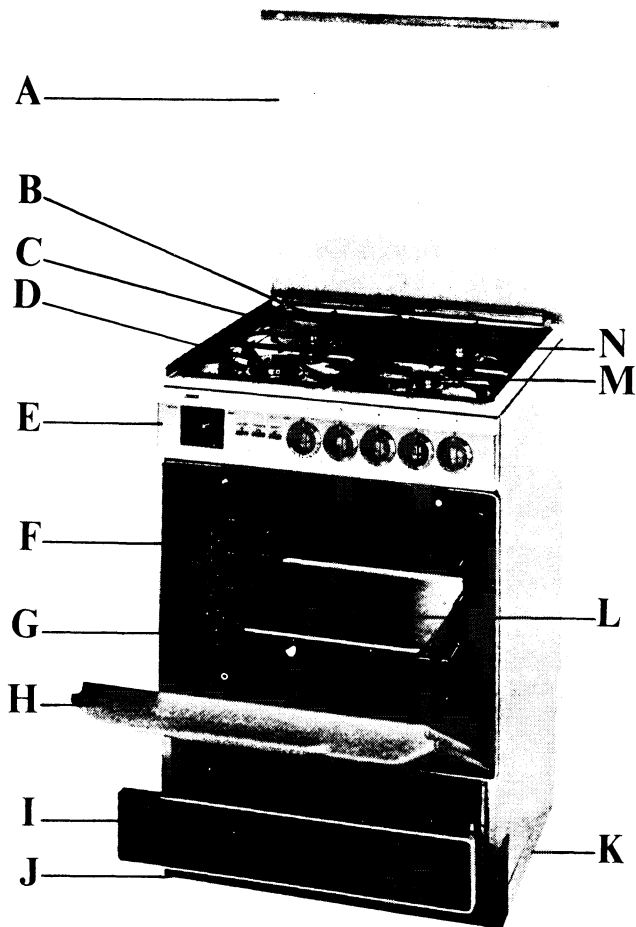

Cooker

A - Cover
B - Safety cut off
C - Semi-rapid burner
D - Rapid burner
E - Control panel
F - Side grilles
G - Grilles

H - Oven door
I - Removable drawer
J - Front panel
K - Removable base
L - Baking tray
M - Auxiliary burner
N - Semi-rapid burner

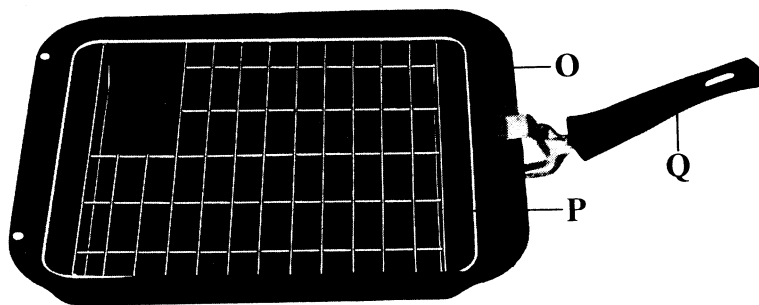

- O - Dripping pan, small
- P - Reversible grill pan insert
- Q - Removable handle

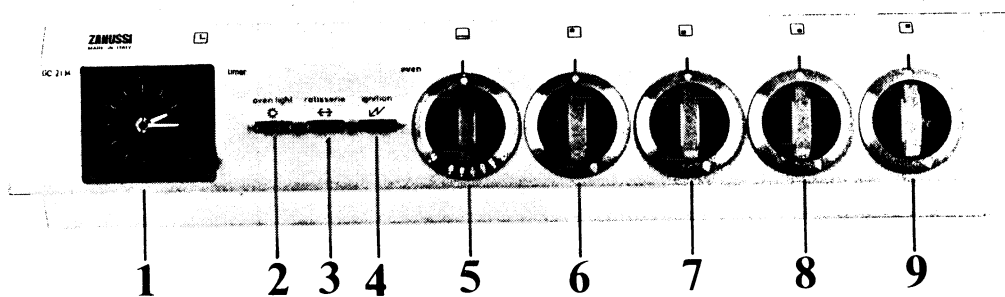

1. Analogue clock
2. Oven light switch
3. Rotisserie switch
4. Lighting button
5. Oven knob
6. Semi-rapid burner knob
7. Rapid burner knob
8. Auxiliary burner knob
9. Semi-rapid burner knob

Operation

Safety cut off

The cooker is equipped with a safety cut off device which totally interrupts the gas supply of the worktop, oven and grill burners.

By lowering the worktop cover, the gas supply is interrupted.

To restore gas supply, lift up the cover and depress the black button placed on the back left of the worktop.

Worktop burners

To light a worktop burner, turn the relevant knob anticlockwise to maximum (Fig. 1).

After opening the tap to maximum, push button marked by a small electric spark. As soon as the burner is lit, adjust the flame as required.

To ensure maximum burner efficiency, it is strongly recommended that you use only pots and pans with a bottom fitting the size of the burner used, so that the flame will not spread beyond the bottom of the vessel.

It is also advisable, as soon as a liquid starts boiling, to turn down the flame so that it will barely keep the liquid simmering.

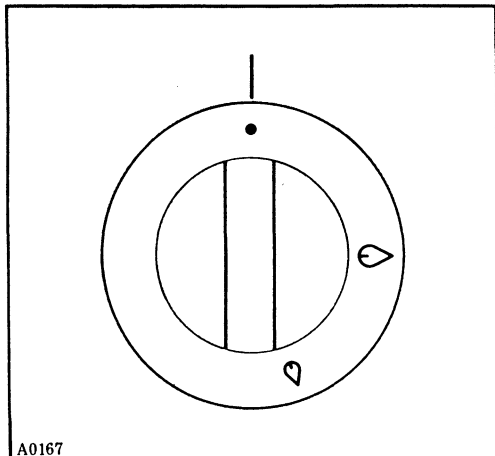

Fig. 1

Important

Be very careful when frying food in hot oil or fat as the overheated splashes could easily flare up.

Gas oven

The oven features a small dripping-pan to collect the gravy when grilling (never use it for baking), a baking tray, a roasting pan to roast and grill food, and two shelves.

Furthermore this oven fits a device which makes the ignition of the burner easier. The instructions are the following:

1. Open the oven door.
 2. Firmly depress the oven control knob (Fig. 2) and turn it anticlockwise to the maximum setting and at the same time operate on the relevant pushbutton marked by a small electric spark. Keep the oven control knob depressed for 10-15 secs.
 3. Release the control knob and then gently close the oven door.
- To adjust the temperature, after a few minutes turn the knob to the required temperature setting.

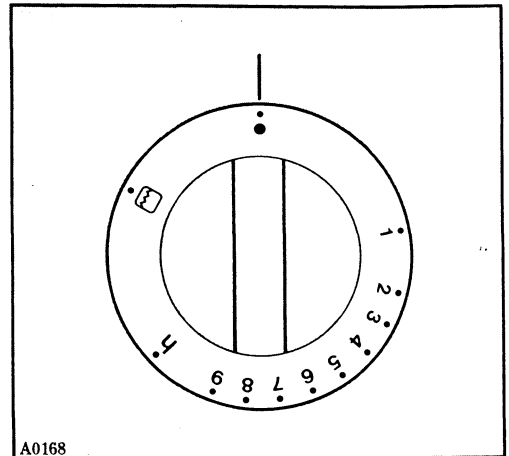



Fig. 2

Gas grill

To light the grill, firmly depress the oven control knob and turn it clockwise to the symbol , then operate on the pushbutton marked by a small spark. Keep the control knob depressed for 10-15 secs; then release the grill control knob.

Oven safety device

The cooker features a thermocouple; if for any reason the flame should extinguish the device will interrupt the gas flow.

Important: Oven and grill burner lighting is possible only if the oven door is opened.

Oven light switch

This switch will turn on the oven light.

Using the grill

Foods to be grilled are to be placed on the wire grid in the grill pan which can be adjusted on the side grids either upwards or downwards to give the required distance from the burner. The pan is then placed in the required runner position.

Important: Because the grill is in the top of the oven, the door must be closed when grilling.

Oven temperature chart

Position	Temperatures	
	°F	°C
1	275	135
2	300	149
3	325	163
4	350	177
5	375	191
6	400	204
7	425	218
8	450	232
9	475	246
h	527-536	275-280

Analogue clock

By turning the knob A (Fig. 3) clockwise or anticlockwise, the analogue clock will show on dial B the required cooking time (max. 180 mins).

When setting a cooking time a sound signal will indicate that the cooking is over.

To stop it turn knob A clockwise until symbol «0» coincides with the index of dial B.

By pulling and turning the knob A either clockwise or anticlockwise you can reset the clock to correct time (f.i. upon installation, following a power failure or when the clock is fast or slow, etc.).

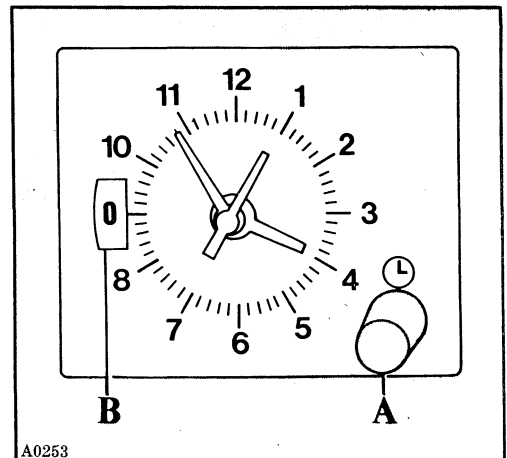

A0253

Fig. 3

Using the rotisserie

The rotisserie can be used for either spit roasting meat or for kebabs and smaller pieces of meat. The accessories for either are provided.

If you want to spit roast a large piece of meat or poultry proceed as follows:

Firstly place one of the two prong forks onto the spit and lock it into position with the thumb nut. Then skewer the meat or poultry onto the spit and secure onto the fork.

Place the second fork onto the spit and skewer it into the meat then lock it in position with the thumb nut.

Place the spit onto the support frame and ensure it turns freely and evenly. If it does not, reposition the meat until it does otherwise excessive wear to the motor will result.

Place the frame and spit into the oven so the spit engages fully into the motor in the back of the oven and depress the rotisserie switch.

Should you wish to use the kebab attachments then proceed as follows:

Firstly place one of the support discs with 4 elongated slots in it onto the spit and secure it by locking the thumb nut about 1½ inches from the handle of the spit.

Next place the disc with the 8 holes onto the spit and secure it in position with the thumb nut. The position of this disc can be decided by judging the distance required against the length of the individual kebab skewers.

Next place the third disc on the skewer positioning it at an equal distance from the centre disc as the first one.

Lock it in position with the thumb nut. Prepare the 8 individual kebab skewers and putting the pointed end through one of the holes on the centre disc.

Lock it in position by placing the other end in an elongated slot in one of the outer discs and turning it.

Repeat this operation for each of the 8 skewers.

Place the spit onto the frame and check that it turns freely and evenly.

If it does not, reposition the weight of the food until it does.

If this is not done excessive wear to the motor will result.

Place the frame and spit into the oven so that the spit engages fully into the motor in the back of the oven.

Place a drip pan on a lower support.

Secure the heat deflector into its position, close the oven door to the ajar position and depress the rotisserie switch.

Oven cooking chart

These times and temperatures are only approximate and for use as a guide. You can use Gas Mark settings higher or lower to cook your food exactly as you like it.

The shelf positions in this oven are numbered from the base up (Fig. 4), and the variations of heat between the top and bottom shelves is approximately one gas mark. It is advisable to follow the recommended shelf positions until you become familiar with your oven.

After turning on the oven and prior to introduce the food it is advisable to wait for about 10-15 minutes to allow the oven to reach the required temperature.

Please remember that the heat comes directly up from the base of this oven. Care must be taken not to place food or dishes directly on to it, neither can it be used to keep dishes warm. To minimise cleaning it is advisable to avoid spilling such things as fruit juice or sugar on to the base of the oven whilst it is hot.

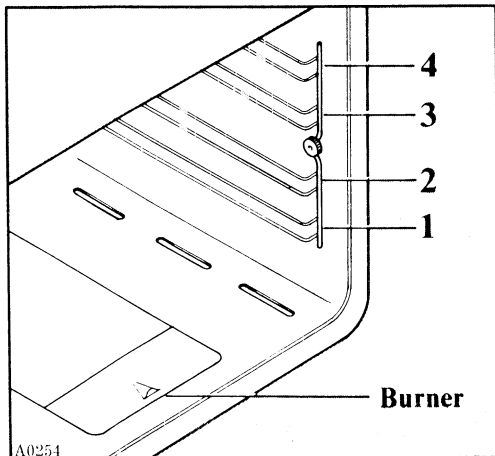

Fig. 4

Therefore, items such as fruit pies or crumbles are best cooked on a baking tray.

For this purpose or for baking never use a full width baking-tray that will obstruct the circulation of heat.

If you wish to bake two identical items simultaneously, keep one free shelf position between them to allow maximum heat circulation. As the food on the lower shelf begins to brown on the base, change the position of the trays around to ensure that the food browns evenly.

If you are in any doubt about baking one of your own recipes, try to find something similar in our own baking guide and follow its recommendations.

Important

The anti-tip oven grid must be positioned as shown in figure 5.

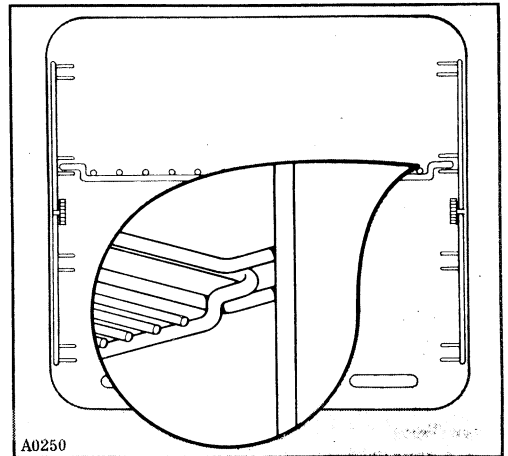

Fig. 5

Oven cooking charts

FOOD	GAS MARK	SHELF POSITIONS	COOKING TIME
MEAT & POULTRY			
Beef with bone	4	1 or 2	20 minutes per lb + 20 minutes
Beef without bone	6	1 or 2	25 minutes per lb + 25 minutes
Lamb	4	1 or 2	20-25 minutes per lb + 20-25 minutes
Pork	5	2	25 minutes per lb + 25 minutes
Chicken	6	2	25 minutes per lb + 25 minutes
Duckling	4	2	30 minutes per lb + 30 minutes
Turkey	3	2 or 3	30 minutes per lb + 30 minutes
Casseroles	2	1 or 2	2½-3 hours
YORKSHIRE PUDDING			
Small	7	3 or 4	25 minutes
Large	7	2 or 3	35 minutes
BAKED VEGETABLES			
	4	2	varies according to the vegetable
PASTRY			
Fruit Tart	6	1	45 minutes
Fruit Pie	6	1 or 2	45 minutes
Sausage Rolls	7	1 and 3	30 minutes
Choux Pastry	Reg 6 for 15 minutes Reg 6 for 10 minutes	2 and 4	25-30 minutes
Vol au Vents	8	2 and 4	15 minutes
Jam Tarts	5	3 and 4	10-15 minutes

FOOD	GAS MARK	SHELF POSITIONS	COOKING TIME
PUDDINGS			
Egg Custard in a Bain Marie	1	1	1-1¼ hours
Pavlova	1	2 or 3	1½ hours
Meringues	1	2 and 4	1½ hours
CAKES			
Rich Fruit Cake 8"	Reg 1 for 2 hours Reg 2 for remainder	2 or 3	3½-4 hours
Plain Fruit Cake	3	2 or 3	2½ hours
Victoria Sandwich	5	3 and 4	25 minutes
Madeira Cake	3	2 or 3	1¾-2 hours
Fairy Cakes	4	3 and 4	30 minutes
Ginger Bread	4	3	45 minutes
Flapjack	4	3	25-30 minutes
YEAST MIXTURES			
Bread 1lb Loaves	7	3	30-35 minutes
Bread 2lb Loaves	7	3	40-45 minutes
Rolls and Buns	7	2 or 3	15-20 minutes
Tea Rings	6	2 or 3	24-35 minutes
Scones	6	3 and 4	15-20 minutes
Shortbread	4	2 or 4 Change trays over halfway through the cooking time	25-30 minutes

Suggestions for meal arrangements

It is sometimes difficult to think of foods which will cook together without requiring constant attention. To assist you in your choice we give you some ideas which will give you some experience on which to base your own ideas.

Meal Arrangement 1 Gas Mark 2

Casserole of Beef Shelf 3
Egg Custard Shelf 1

To enable the egg custard to cook very gently, place it in a Bain Marie and cook it for approximately 1 hour. As the casserole of beef will take approximately three hours to cook this gives you spare space in which to cook vegetables if you choose to.

Meal Arrangement 2 Gas Mark 6

Toad in the Hole Shelf 3
Apple Pie Shelf 1

Pre-heating the sausages with the lard and turning them over before the batter is poured on to them will enable both of these dishes to cook in approximately 45 minutes.

Meal Arrangement 3 Gas Mark 5 & 6

Roast meat
with Roast Potatoes Shelf 1 or 2
Yorkshire Pudding Shelf 3 & 4

When cooking a roast joint always use the roasting pan that is supplied with the cooker and not a full width one that will obstruct the circulation of heat. One hour before the meat is due to be ready, place the par-boiled potatoes around the joint (turning them over once or twice during the cooking time). Turn the regulo up to 6 and get the fat in which you are going to cook the yorkshire pudding very hot before pouring in the mixture. The shelf position that you choose for the yorkshire pudding depends on the thickness of the joint below it.

Meal Arrangement 4 Gas Mark 4

Moussaka Shelf 2
Leicestershire Apple Cake Shelf 4

Bake for 40-45 minutes, changing the dishes after 30 minutes cooking time. You may wish to grill the top of the Moussaka to brown it more.

Maintenance

For a long service life of the appliance we strongly recommend that you frequently carry out a thorough cleaning operation.

Cleaning the oven

Always wait until the oven is cool before cleaning.

It is advisable to release the oven side rails.

All enamelled parts should be washed with lukewarm water and detergent without using abrasive products which might damage them.

The oven should be cleaned inside with the greatest care, after each use, with hot water and detergent (or one of the special products available on the market).

When cleaning the oven, be careful to protect the aluminium parts of the control panel from chemical compounds contained in the products used to clean the enamelled parts.

Removing the panels

Unscrew the ring nuts securing the side grilles (Fig. 6), remove the grilles and then remove the side panels (Fig. 7).

Cleaning the worktop

Burner caps should be frequently washed in hot water and detergent, being careful to remove all incrustations.

Thoroughly clean the terminal part of the automatic lighting device to prevent a difficult lighting and, furthermore, make sure that the flame spreader gas openings are unobstructed.

Stainless steel parts should be carefully rinsed with water, after each use, and then dried with a clean soft cloth or with a buckskin.

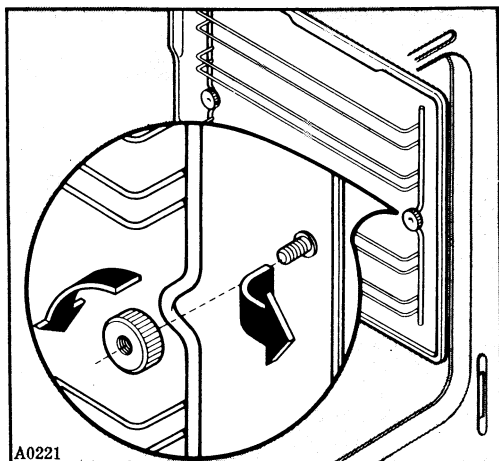

A0221

Fig. 6

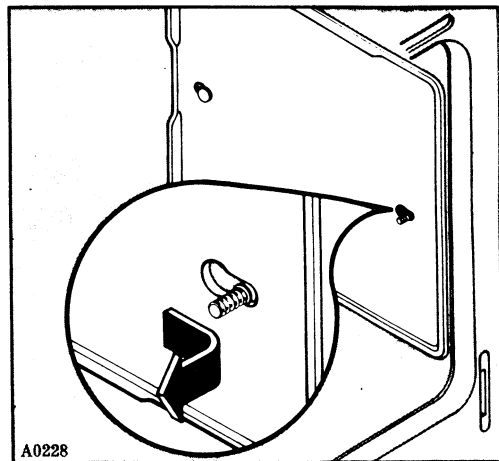

A0228

Fig. 7

In the case of persistent spots you may use normal non-abrasive detergents, currently available on the market, or some hot vinegar.

Never use steel-wool pads, chlorine or similar products which might scratch, grind or etch the metal.

To clean the cover use liquid or creamy detergents, thus avoiding the use of powder abrasives, rough sponges or steel wool.

Also, never close the cover while the burners are still warm.

Replacing the oven lightbulb

Disconnect the appliance from the electric supply.

Unscrew the lightbulb glass protection from the oven. Unscrew the lightbulb and replace it with a new bulb suitable for high temperature (300°C) and having the following technical features:

Operating voltage: 240V - 50Hz

Power absorbed: 15 W

Removing the oven door (Fig. 8)

To thoroughly clean the oven you should remove the door by proceeding as follows:

Open the door as far as it will go.

With the aid of a coin, turn the oven door stops (catches) 45° to the right.

Slide off the door.

After having cleaned the door, lift up hooks provided under the hinges and reassemble the door carrying out above operations in the reverse order.

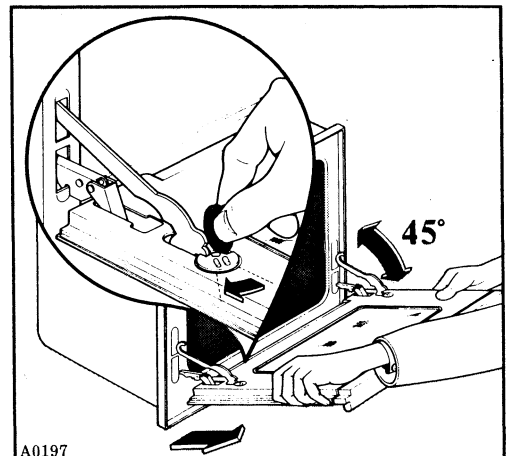

Fig. 8

Instructions for the installer

Installation

The following instructions are meant for a qualified installer and should assist him in carrying out all installation, adjustment and maintenance operations in the most correct way and in accordance with existing laws and regulations.

Important

Before servicing the appliance or undertaking any maintenance work on it, be sure to disconnect it from the electric supply. Should it be absolutely necessary to keep the appliance «live» take all possible precautions to prevent accidents.

Positioning

To ensure a troublefree operation of the appliance, it is a must that it be set up in a well ventilated kitchen (in this connection, the installer needs only comply with existing rules and regulations).

The cooker may be positioned in such a way as to come into touch with the sides of the kitchen furniture. However, the latter must be able to withstand a temperature increase of 60°C.

The appliance incorporates a removable base (A - Fig. 9-10) which permits the alignment with kitchen furniture having a height of 85 cms, plus levelling feet (B - Fig. 9-10).

To remove the metal base rest the appliance on a side, slide out the front plastic panel (C - Fig. 9) which is push-fitted and then unscrew the six screws (D - Fig. 9) that secure the base to the cabinet.

Remove the levelling feet from the base (B - Fig. 9-10), screw them onto the cabinet and then fit the new front panel (optional) (E - Fig. 10).

Position the appliance.

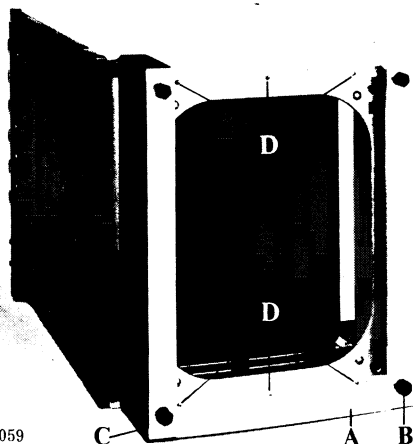

A0059
Fig. 9

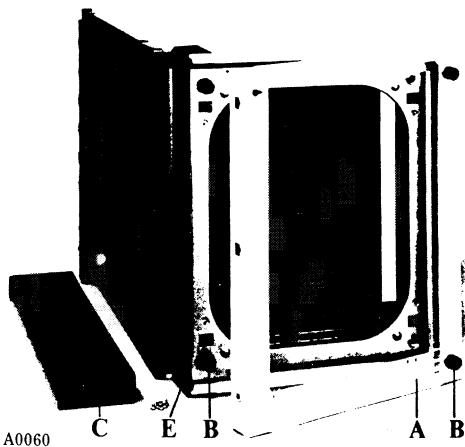

A0060
Fig. 10

The appliance incorporates a set of adjustable feet.

By properly adjusting the feet, the appliance can be set up at the required height and correctly aligned with the kitchen furniture or any other surface, thus ensuring an even spreading out of liquids in pans and pots.

These adjustable feet are easily accessible after removing the dish-warming drawer. To remove this drawer, proceed as follows:

pull out the drawer to the limit stop in order to slide out completely the side runners;

shift the front rollers up to the «buttonholes» of the side runners;

lift up the drawer and slide out the front rollers;

pull out the drawer and shift the rear rollers up to the «buttonholes» of the side runners;

lift up the drawer and slide out the rear rollers;

to replace the drawer, reverse the above procedure.

Electrical connection

This appliance features a three-pole electric supply cable, having a plug with fuse, and is designed to operate on alternating current, with a single phase voltage of 240 V - 50 Hz.

The ground wire is green & yellow coloured.

The oven features an easily accessible terminal board with the following markings:

L = Live N = Neutral ⊕ = Earth

Connecting the supply cable to the mains

Insert the plug into a standard wall socket suitable for the load shown on the rating plate.

If you require a direct connection to the electric network (mains), it will be necessary to fit between the cooker and the mains an omnipole switch, with a minimum aperture between contacts of 3 mm, suitable to carry the required load and conforming to the ruling specifications.

The green & yellow ground wire must not be interrupted by the switch.

The supply cable must at any rate be placed in such a way as to ensure that it does not reach at any given point a temperature 50°C higher than the ambient temperature.

Prior to connecting the cooker to the electricity supply make sure that:

the protection fuse and the domestic wiring are suitable to carry the total electric load of the cooker (see rating plate);

the electricity supply network (mains) has an efficient earth connection according to the established rules and existing regulations;

with the cooker definitely installed, the wall socket or the omnipole switch can easily be reached.

The Manufacturer disclaims any liability in case these accident-preventing rules are not observed.

Important

The heat insulation of the oven and grease residues from the manufacturing process produce smoke and an unpleasant smell during the first minutes of operation.

It is therefore advisable, the first time the appliance is used, to pre-heat the oven for about 30 mins. at peak temperature without putting any food into it.

Gas connection

Connect the cooker to the gas mains, in accordance with existing rules and regulations.

Important

To ensure a safe operation, a lower consumption and a longer service life of the appliance, make sure that the feed pressure is in accordance with the specifications given in the «burner and nozzle features» chart.

Stiff connection

In case of connection to the gas mains by means of a metal pipe & fittings, make sure that this does not put any strain on the appliance.
The cooker has a 1/2" threaded gas inlet.

Attention

The cooker is adjusted for NATURAL GAS (METHANE).

Burner and Nozzle Features Chart

Burner	Nominal Power		Natural gas (Methane)	
	kC	kW	Nozzle	l/h 15°C
Small (dia. 40 mm)	860	1,0	79	95
Medium (dia. 60 mm)	1700	2,0	110	190
Big (dia. 90 mm)	2800	3,2	140	304
Oven	2600	3,0	120	288
Grill	2300	2,7	115	255
Feed Pressure	nom. (mbar)*		20	
	min. (mbar)*		18	
	max. (mbar)*		25	

* 1 mbar = 10 mm water column

Taps

Burner	Dia. Tap By-Pass	Tap colour
Small	42	Red
Medium	45	Yellow
Big	55	Black

Oven Thermostat

By-pass Pin Dia. for natural gas «0.70».

Maintenance

Check at regular intervals the condition and serviceability of the gas connection hose and pressure regulator, if any; in case of malfunction, do not repair but replace the whole faulty part.

To ensure a smooth and safe operation, it is necessary to periodically grease the gas taps.

Servicing should be carried out by qualified personnel as follows:
remove the knobs and slide out the front panel after removing the securing screws.

Unscrew the two screws to be found next to the gas tap shaft.

Slide out the cone and clean it thoroughly; finally, apply a thin layer of grease of a type non-soluble to hydrocarbons and suitable for gas taps.

Make sure that no excess grease obstructs the gas tap holes.

Refit everything very carefully reversing the above procedure.



ZANUSSI STANDARD GUARANTEE CONDITIONS

This guarantee is in addition to your statutory and other legal rights which will not be excluded or in any way diminished by the return of the guarantee card.

We, Zanussi Limited, undertake that if, within twelve months (24 months for TV sets) of the date of the purchase, this ZANUSSI appliance or any part thereof is proved to be defective by reason only of faulty workmanship or materials, we will, at our option, repair or replace the same **FREE OF ANY CHARGE** for labour, materials or carriage on condition that:

—The appliance has been correctly installed and used only on the electricity supply stated on the rating plate.

—The appliance has been used for normal domestic purposes only, and in accordance with the manufacturer's operating and maintenance instructions.

—The appliance has not been serviced, maintained, repaired, taken apart or tampered with by any person not authorised by us.

—The appliance is still in the possession of the original purchaser.

All service work under this guarantee must be undertaken by a Zanussi Network Service Centre (or the Zanussi Authorised TV Service Dealer).

Any appliance or defective part replaced shall become our property.

Exclusions

This guarantee does not cover:

—Damage or calls resulting from transportation, improper use or neglect, the replacement of any light bulbs or removable parts of glass or plastic.

—Costs incurred for calls to put right machines improperly installed or calls to machines outside the UK and the Republic of Ireland.

—Appliances found to be in use within a commercial environment, plus those which are the subject or rental agreements.

—Television receivers - routine adjustment, or poor reception resulting from a source outside of the receiver.



ZANUSSI 5 YEAR COVER CONDITIONS

For a once-only payment you can extend your Standard Guarantee to 5 years. All the conditions and exclusions of the Standard Guarantee apply.

Notes

1. Products supplied as "seconds", refurbished, damaged or shop-soiled are not eligible for Zanussi 5 year cover.
2. The issue of a cover does NOT by virtue of our having done so, nullify the exclusions.
3. The Engineer will need to check the details of your Cover card and may make a charge for his services if it is not presented to him at the time of his call.
4. The date of purchase, or the date of initial payment (deposit) of the appliance will be deemed the date of commencement of cover.
5. Covers issued are not refundable or transferable.

ZANUSSI
The appliance of science