

Users Guide

Installation & Servicing



Model ACG 902 IX

NOTE TO INSTALLER: LEAVE THE OWNER'S GUIDE MANUAL WITH THE APPLIANCE.
(Keep For Future Reference)

RECORD HERE FOR EASY REFERENCE

Model..... Colour.....
Serial Number..... Installation Date.....
Dealer's Name and Address.....

GENERAL INFORMATION

ENVIRONMENTAL WARNING

Waste packaging

Do not throw the packaging of your appliance into the dustbin, but pick out the different materials (for instance foil, paperboard, polystyrene) according to the local rules for rubbish elimination.

This appliance must only be used for the purpose of domestic cooking.

Getting to know your new cooker

Thank you for choosing one of our products. Our cookers are of simple, rational design. They are constructed to the best standards to ensure good service and outstanding safety.

Please read this manual carefully; it will provide all the advice needed to allow you to obtain the best results from the very first day.

ATTENTION:

- Before using the appliance, do not forget to remove the plastic protective film from parts of the appliance.

• **WARNING** - Accessible parts will become hot when in use. To avoid burns and scalds children should be kept away.

- WARNING -

In order to prevent accidental tipping of the appliance, for example by a child climbing onto the open oven door, the stabilizing means must be installed.

- WARNING

This appliance is not intended for use by persons (including children) with reduced physical, sensory or mental capabilities, or lack of experience and knowledge, unless they have been given supervision or instruction concerning use of the appliance by a person responsible for their safety.

Children should be supervised to ensure that they do not play with the appliance.

Young children and infirm persons should not be left unsupervised in the vicinity.

- WARNING

Before you use the appliance for the first time, check that the plastic films protecting some parts (fascia panel, parts in stainless steel, etc.) have been removed.

- WARNING:

A steam cleaner is not to be used cleaning this appliances.

- WARNING

DO NOT place inflammable materials or plastic utensils in the warming drawer.

DO NOT SPRAY AEROSOLS IN THE VICINITY OF THIS APPLIANCE WHILE IT IS IN OPERATION.

Not for use in marine craft, caravans or mobile homes unless each burner is fitted with a flame safeguard.

WHERE THIS APPLIANCE IS INSTALLED IN MARINE CRAFT OR IN CARAVANS, IT SHALL NOT BE USED AS A SPACE HEATER

DO NOT MODIFY THIS APPLIANCE.

WHEN YOU CALL FOR SERVICE

Customer Service: 1300 363 344
Service call booking: 1300 361 166

Whirlpool Europa S.r.l.
Viale G. Borghi, 27
21025 Comerio (VA) Italy

When you call for service or order parts for your unit, be sure to give:

1. MODEL
2. SERIAL NUMBER
3. COLOUR
4. PART NAME and/or description of problem
5. YOUR FULL NAME, ADDRESS, and HOME TELEPHONE NUMBER and BUSINESS TELEPHONE NUMBER IF APPROPRIATE.

SECTION FOR THE QUALIFIED TECHNICIAN

OVERALL DIMENSIONS

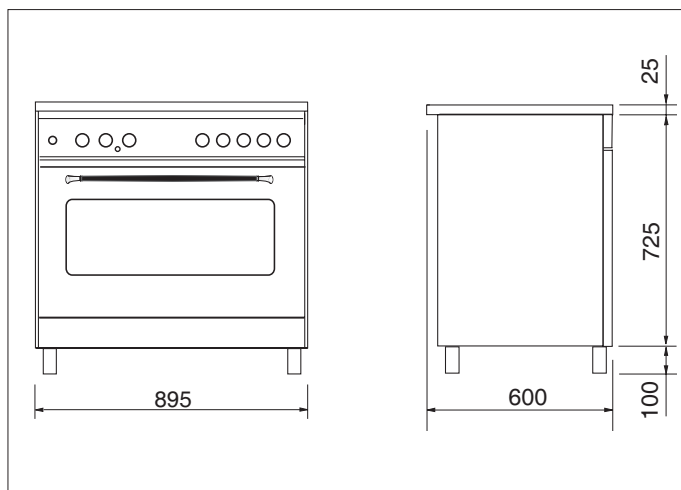

POSITIONING

If the range is placed on a base, ensure measures are taken to prevent the product slipping off the base

Make sure that the wall surface behind the Cooker is non-combustible (will not catch fire). A plastered or tiled wall is ideal. Where a painted surface is adjacent, a fire retardant paint surface is recommended. Wallpaper, wood, or fabric should not be used behind or next to the cooker.

Any adjoining wall surface situated within 200mm from the edge of any hob burner must be suitable non-combustible material for a height of 150mm for the entire length of the hob. Any combustible construction above the hotplate must be at least 650mm above the maintop.

INSTALLATION

PROVISION FOR VENTILATION

The room where the Cooker is installed should have permanent ventilation as follows:

"Ventilation must be in accordance with AS5601-2004 - Gas Installations. In general, the appliance should have adequate ventilation for complete combustion of gas, proper flueing and to maintain temperature of immediate surroundings within safe limits."

- Do not install in a bed-sitting room, a bathroom or shower room.
- If there is another fuel burning appliance in the same room, a higher level of ventilation will be required, you should consult "the safety requirements".

In addition to the above, during prolonged use, opening a window in the same room is recommended. This will avoid the build up of excessive moisture and condensation.

POSITIONING

Important: Fix the chain located next to the gas connection on both sides of the cooker to the wall to prevent the cooker from tilting. Both chains must be securely fixed.

Make sure that the wall surface behind the Cooker is non-combustible (will not catch fire).

Where a painted surface is adjacent, a fire retardant paint surface is recommended. Wallpaper, wood, or fabric should not be used behind or next to the cooker.

Clearances to combustible materials

"Any adjoining wall surface (side or rear) situated within 200mm of any hob burner must be a suitable non-combustible material from the edge for a height of 150mm for the entire length of the cooker.

Any combustible construction above the cooker must be at least 650mm above the maintop." Ensure that a power and gas supply are nearby. The Cooker should be located carefully so that the heat produced by it has plenty of space to escape. The diagram below shows an ideal configuration.

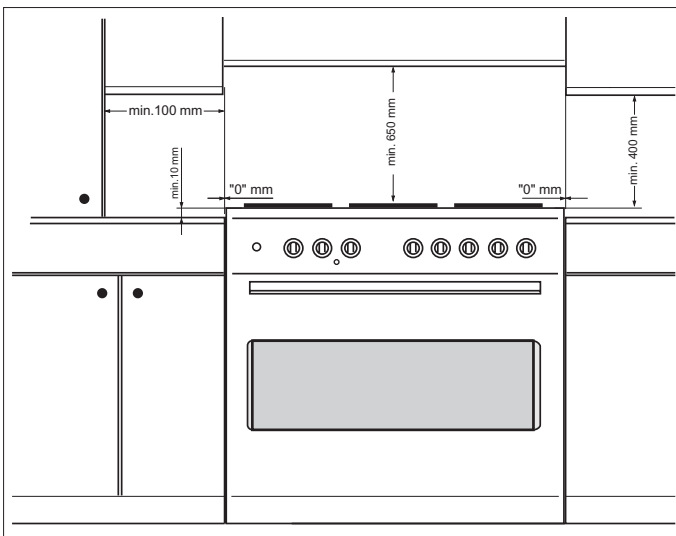

No part of any adjoining wall surface can be made of combustible materials. The protection of combustible materials required by Clause 5.12.1.1 of AS5601-2004 is the fixing of 5 mm thick ceramic tiles to the surface or attaching fire resistant material to the surface and covering with sheet metal with a minimum thickness of 0.4 mm.

Clearances to non-combustible materials

"If the cooker is being fitted next to cupboards or adjoining wall surfaces, which are within 200mm from the edge of the hob burner and of a suitable non-combustible material as specified in AS5601, then ensure that a distance of at least 6cm is left between the edge of the cooker and the non-combustible material. This gap is to allow plenty of space for the heat produced by the cooker to escape on each side of the cooker.

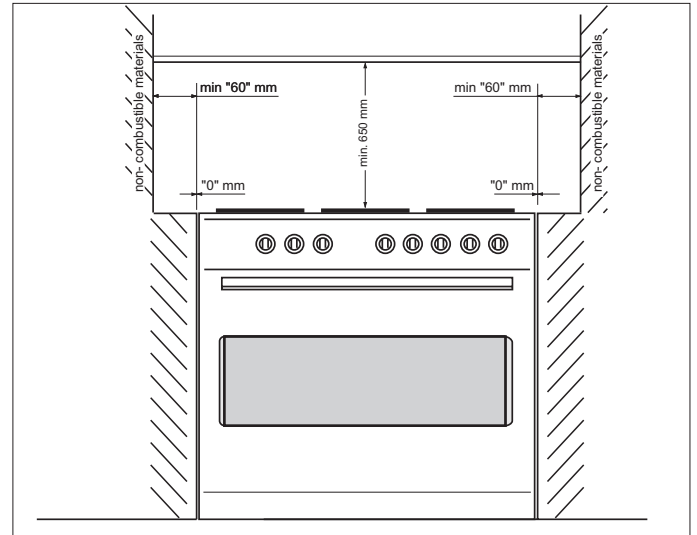

Note:

The cooker is fitted with 4 legs which must be assembled as shown in figure 1B.

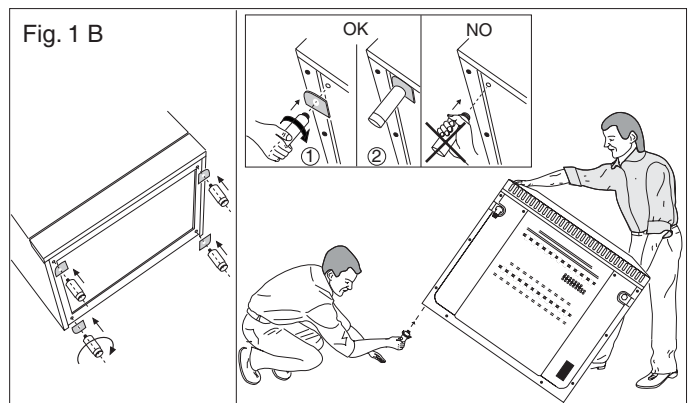

TO FIX THE COOKER TO THE REAR WALL

WARNING - For safety reasons and to prevent tipping of the appliance, these stabilizing means must be installed.

The cooker is equipped with 2 chains fixed on each side at the rear of the cooker near the top (see Fig. A). The chains are fitted with "spring clips" which must be clipped to the "screw eyes" provided with the cooker. Install the "screw eyes" as follows :

1. Drill four 6mm holes (position 1 - 2 - 3 - 4) in the wall as in Fig. A.
2. Insert part "R" into the holes then screw in the "screw eyes" part "G" see Fig. B.
Note: If the part provided is not suitable for the wall material please use an appropriate device to ensure secure holding of the "screw eyes" to the wall.
3. Bring the cooker near the wall and clip the chains on the "screw eyes" as in Fig. C.

IMPORTANT: If the cooker is moved for any reason (e.g. maintenance) resulting in the cooker being unclipped from the wall, the cooker must be re-clipped to the wall at the completion of the task.

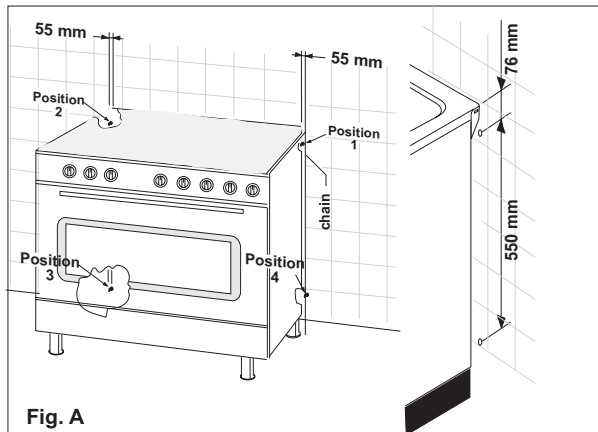

Fig. A

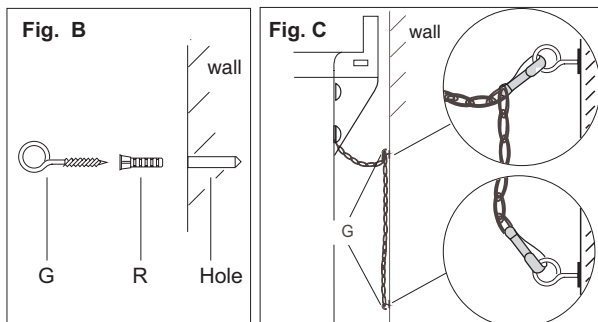

Fig. B

Fig. C

GAS CONNECTION

Gas Installation must be made in accordance with AS5601; also refer to rangehood manufacturers recommendations.

Check gas pressure, note the correct setting from the data plate sealed inside the front appliance drawer * .

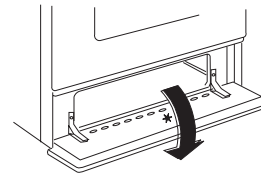

Installing the Gas Cooker:

(Flexible connections are NOT permitted with this appliance)

- An inlet manifold extension pipe must be fitted to the appliance. Part supplied in the drawer of the appliance.
- Ensure that the pipe is connected using the washer provided and that the bracket is screwed to the appliance as shown in the diagram below.
- Fit the supplied pressure regulator. Ensure the arrow is pointing towards the appliance and that the pressure test point is accessible from under the appliance when the product is pushed back into the final position.
- Push the cooker back and install the stabilizing chains.
- Connect the appliance inlet manifold to the fixed consumer piping outlet using only fixed piping. This final connection is made when the product is pushed back into position by access under the cooker.

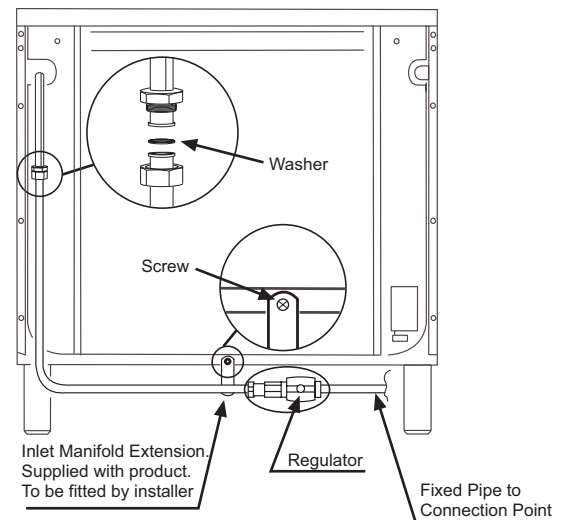

IT IS RECOMMENDED THAT A SERVICE TAP AND UNION BE FITTED ADJACENT TO THE APPLIANCE INLET TO FACILITATE FUTURE SERVICING.

5 burner models: set the burner pressure to 1kPa for Natural Gas and 2.75kPa for U-LPG with the wok burner operating a full rate. For commissioning of the appliance with the Bromic regulator for Natural Gas , the test point pressure should be 1.00kPa with all burners operating on HIGH.

Apply a manometer to the test nipple and reset the regulator if necessary. Do not forget to replace the test nipple screw and to leave the instruction book with the user.

This appliance from the factory suitable for NATURAL gas but, if necessary, can be adjusted for U-LPG by authorised person. For the adjustments to U-LPG please operate as specified in the paragraph GAS CONVERSION AND ADJUSTMENT (pag 4).

The Gas Connection is male 1/2" BSP and is situated at the right or left, hand rear of the appliance, approximately 40mm from the side. The appliance shall be installed by an authorized person in accordance with the manufacturer's installation instructions, relevant local fitting regulations, municipal building regulations, the AS5601 code for gas burning appliances and equipment and

other relevant statutory code band regulations. If you have some doubts, please contact the authorities for confirmation concerning the characteristics of the gas and electricity output.

The appliance is generally preset for natural gas (so no other adjustment is necessary) ensure regulator is fitted for N.G.

Ensure that all foreign matter has been cleared from the gas supply line and also purge all air from the gas system. Connect to regulator, tighten and check the installation to ensure no gas leaks occur.

VERY IMPORTANT FOR THE INSTALLER

Do not attempt to turn or stress threaded elbow of the manifold: you risk damage to this part of the gas appliance which may void the manufacturers warranty.

Before Leaving – Check all connections for gas leaks. DO NOT use a naked flame for detecting leaks. Ignite all burners to ensure correct operation of gas valves, burners and ignition. Turn gas taps to low flame position and observe stability of the flame.

When satisfied with the cooker, please instruct the user on the correct method of operation.

In case the appliance fails to operate correctly after all checks have been carried out, refer to the authorised service provider in your area.

- change the injector (see Fig. 1A) and replace it with another one suitable for the new type of gas (see tab. 1)

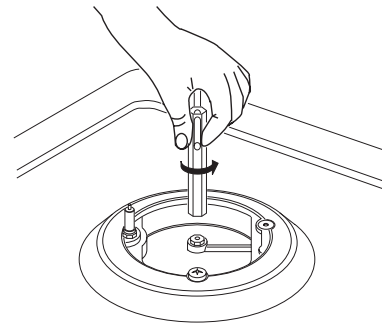

Fig. 1A

MINIMUM FLOW ADJUSTMENT FOR HOB-TOP TAPS

In order to adjust the minimum flame setting proceed as follows: switch the burner on, and set the knob at the minimum position. Remove the knob from the tap, place a small bladed screwdriver down the centre of the tap shaft (fig. 2A).

Attention: on taps with a security valve, the minimum adjusting screw «Z» is on the body of the gas tap (fig. 2B).

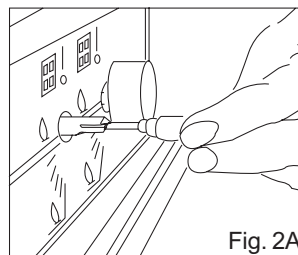

Fig. 2A

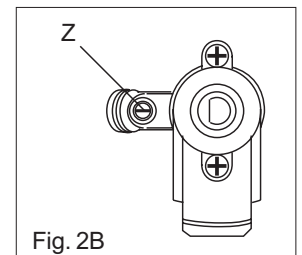

Fig. 2B

Unscrew the adjusting screw in order to increase the flow or screw it to decrease the flow.

The correct adjustment is obtained when the flame has a length of about 3 or 4 mm.

For butane/propane gas, the adjusting screw must be screwed in tight.

Make sure that the flame does not go out turning quickly from the max. flow 🔥 to the minimum flow 🔥.

Refit the knob again.

GAS CONVERSION AND ADJUSTMENT

When used with natural gas all burners have been preset at our factory and further adjustment should not be necessary. Conversion kits to other gases are available from the place of purchase. Do not attempt to fit the conversion kit yourself. Conversion to U-LPG gas should only be carried out by an authorized technician.

GAS ADJUSTMENTS

- change the injectors
- adjust the minimum flow

‘When converting from Natural Gas to U-LPG ensure that the NG regulator is removed and replaced with the Test Point Assembly. A gas regulator suitable for a supply pressure of 2.75kPa should be part of the gas tank supply and should be adjusted with the wok burner operating at maximum.

REPLACEMENT OF THE INJECTORS

When required to operate on other gas replace the injectors in accordance with information referred to in chart below.

TAB. 1

Gas Type	kPa	Jet mm Ø	Burners	Power MJ/h
Natural Gas	1.00 kPa	0.90	Auxiliary	4.0
		1.20	Semi-rapid	7.1
		1.50	Rapid	11.0
		1.63	Wok	12.7
U - LPG	2.75 kPa	0.53	Auxiliary	3.7
		0.73	Semi-rapid	7.0
		0.95	Rapid	11.7
		1.00	Wok	12.7

SPECIAL NOTE

After installation or any servicing operation, always ensure that the appliance is gas sound and that the components are now operating correctly. Items removed during servicing should be replaced in the reverse order to their removal.

In order to change the work-top injectors, it is necessary to act as follows:

- remove the grids
- remove burners and flame-spreaders.

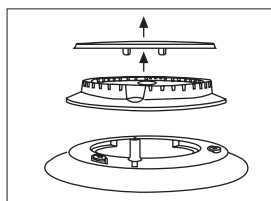

ELECTRICAL CONNECTION

The appliance must be installed by a suitably qualified person in accordance with these instructions and with the requirements of the Australian Wiring Rules AS/NZS 3000. Fixed wired installations are to be provided with suitable isolation means in accordance with the said rules.

Any plug socket installed for the purpose of connecting the appliance to supply must be readily accessible when the appliance is installed.

Before making the connection, make sure that:

- 1) the safety circuit-breaker and the electrical system are able to withstand the load of the appliance (see nameplate).
- 2) the power supply system has an earth connection in good working order in accordance with the regulations in force;

IMPORTANT

The wires in the mains lead are coloured in accordance with the following code:

GREEN & YELLOW.....EARTH
 BLUE.....NEUTRAL
 BROWN.....LIVE

Electric power.....1,5 mm² core cable (15 amp. Fuse required)
 Should conform to local authority requirements.

Also refer to rangehood manufacturers recommendations.

This appliance is supplied with a plug & cord, simply plug into a 3 pin household socket outlet which is properly earthed.

WARNING: THIS APPLIANCE MUST BE EARTHED.

The flexible mains lead and plug must not be in contact with hot surfaces.

'In order to avoid hazard, any electrical work performed on this equipment or its associated wiring, should only be done by persons authorised by the supplier or similarly qualified persons.'

WARNING:

Children should be kept away while the oven or grill is in use since accessible parts become hot.



- Do not use oven base panel as a shelf, make use of the oven shelves.
- To avoid splattering and smoke, position collecting tray under the grill with some water in it.
- Always turn pan handles to the side or to the back of the hob. If they are left out into the room they can easily be hit or reached by children, this knocking the pan off the hob.
- Don't let children sit down or play with the oven door. Do not use the drop down door as a stool to reach above cabinets.
- Once your cooking is over make sure to close the main gas supply.

WARNING - In order to prevent accidental tipping of the appliance, for example by a child climbing onto the open oven door, the stabilizing means must be installed.

WARNING

- * This appliance is not intended for use by young children or infirm persons without supervision.
- * Young children should be supervised to ensure that they do not play with the appliance.

PROGRAMMER WITH COOKING END TIME

For a manual operation of the programmer, turn the knob anticlockwise to .

Adjust the cooking time by turning the knob clockwise.

Select the cooking time with the relevant knob (max.120 min.).

The oven will switch off automatically when the cooking is up.

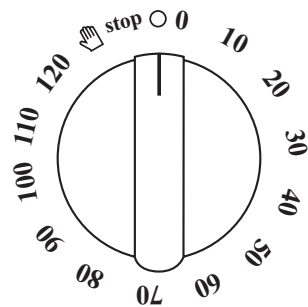

- 1 Minute Tour -

Be safe

Please read the rest of the instruction book which contains important information to help you use the appliance safely and efficiently.

Gas and Electricity on

Make sure that the gas supply is turned on and that the appliance is plugged in and switched on. The ignitor needs electricity.

In case there is no electric current, the burner can also be lighted using a match.

It is recommended that pans suitable to the size of the burner should be used as follows:

BURNERS	PANS	
	fl min.	fl max
AUXILIARY	80 mm	160 mm
SEMI-RAPID	120 mm	200 mm
RAPIDE	200 mm	230 mm
TRIPLE CROWN	230 mm	260 mm

Always use pans with a flat base diameter, which are well balanced and stable in use, a pan which overhangs the hotplate should not be used. Avoid using old, misshapen pans, or pans which are unstable when placed on a flat surface. Do not use "split pans" as they are inherently unstable.

To save gas, always position pans centrally over the burners and adjust the flames so that they do not lick up the sides of the pan and only the base is heated. Always put lids on saucepans and boil only the amount of liquid you use. When the liquid has boiled adjust the setting to maintain a simmer. Do not light the burner until the pan is in position and turn off the burner before removing the pan. In hard water areas, descale kettles regularly. For safety, keep saucepan handles turned to a safe position so they are out of reach of small children and cannot be accidentally knocked.

To turn the burner OFF, turn the control knob clockwise to the OFF setting (marked with a dot ●)

Automatic electric ignition

To turn on a burner, press the knob corresponding to the selected burner and turn it anticlockwise to the maximum position. Keeping the knob pressed, the electric automatic ignition of the burner will be started up. In case there is not electric current, the burner can also be lighted using a match.

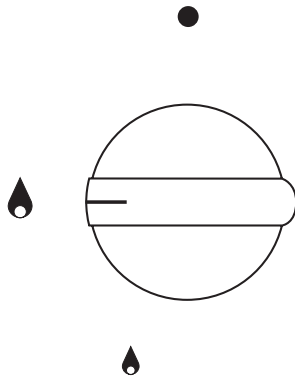

The small flame indicates the 'low position'.

Turn the knob to it after the contents of a pan have boiled.

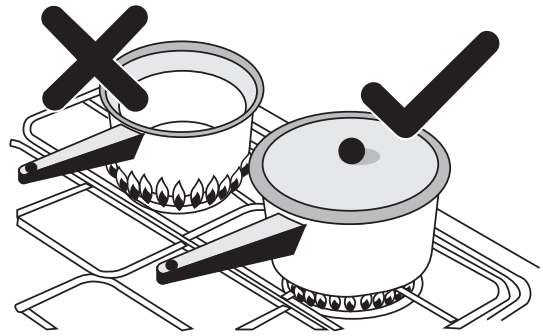

The smaller burners are for smaller pans and simmering. Make sure flames are under the pans. Using a lid will help the contents boil more quickly.

WARNING

It is not recommended to press push button for ignition if all the burners are not located in the proper positions. The burner heads, burner skirts and pan supports are removable for better cleaning: Always ensure that the burner skirts and heads are replaced correctly so that the burners function safely and correctly. During the use of the appliance pay attention that water or any liquid does not enter into the appliance through the holes of the burners or around the rods of the valves or the push button electronic lighter.

Water or juice will produce dangerous short-circuits and can seriously damage the working of the Hotplate.

HOW TO USE YOUR ELECTRIC OVEN

- Before cooking in the first time we recommend that the oven should be operated at 200° C for 30 minutes to remove any manufacturing greases and odours.
- Do not place items or pan directly on to the oven bottom.
- Foil should only be used to cover food and not oven shelves or party of the oven. When used improperly will obstruct the air circulation causing problems in cooking and/or harmful accidents.

MULTIFUNCTIONAL OVEN

The oven is fitted with:

- a lower heating element;
- an upper heating element;
- a circular heating element surrounding the fan.

N.B.: Always set the temperature on the thermostat knob before selecting any of the functions.

Oven thermostat knob

To obtain an oven temperature between 60°C and MAX°C, turn the knob clockwise.

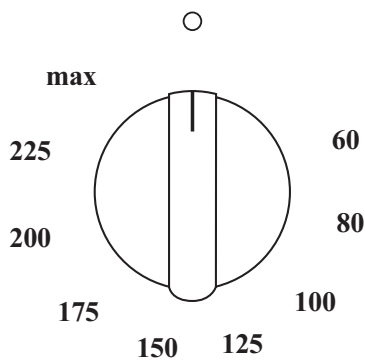

Oven commutator knob

Depending on the type of oven, it is possible to select one of the following functions turning the commutator knob clockwise.

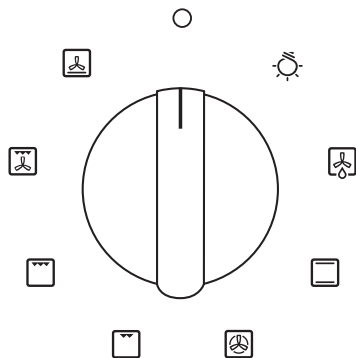



Note:

All the functions mentioned above switch the oven internal light on. A warning light on the control panel will stay lit until the temperature is reached; after it will light up intermittently.



Always use the oven with the oven door closed.

Use of the oven

Note: ovens with separate thermostat and commutator.

When the functions   are used, place the thermostat knob between 180 ÷ 200°C as maximum temperature.

ATTENTION:

The temperature shown on the control panel corresponds to the temperature in the oven centre only when the functions selected are  or .



When you turn the control knob to this position, the light will be on for all the following operations.



Defrosting with fan

The air at ambient temperature is distributed inside the oven for defrosting food very quickly and without proteins adulterations.



Natural convection

Both the lower and upper heating elements operate together. This is the traditional cooking, very good for roasting joints, ideal for biscuits, baked apples and crisping food. You obtain very good results when cooking on a shelf adjusting the temperature between 60 and MAX°C.



Fan oven

Both the fan and the circular heating element operate together. The hot air adjustable between 60 and MAX°C is evenly distributed inside the oven. This is ideal for cooking several types of food (meat, fish) at the same time without affecting taste and smell. It is indicated for delicate pastries.



Medium grill

It is indicated for grilling and gratinating small quantities of traditional food.

The thermostat knob must be placed on the maximum position.



Total grill

It is indicated for grilling and gratinating traditional food. Turn the thermostat control knob to the 200°C position.



Fan assisted total grill

The air which is heated by the grill heating element is circulated by the fan which distributes the heat on the food. The fan assisted grill replaces perfectly the turnspit. You can obtain very good results also with large quantities of poultry, sausage, red meat. Turn the thermostat control knob to the 200°C position.



Air forced lower heating element

The air which is heated by the lower heating element is circulated by the fan which distributes the heat on the food. This function can be used to sterilize food. This function can be used between 60 and MAX°C

GENERAL INSTRUCTION

Warning: remember ovens get hot; some parts naturally become very hot, notably the glass oven door and the protective strip. Keep children away from oven at all times and warn them about the danger.

GUIDE FOR CONVENTIONAL COOKING

(Outer ring of upper electric element and lower electric element ON) The following Cooking Guides give the recommended shelf positions (counted from the bottom), thermostat settings and approximate cooking times for a range of baked items, using the conventional oven, using one tray only. Cooking results are a matter of personal preference and may easily be adjusted to suit individual requirements by slight adjustment of the temperature and or cooking time. Preheating of the oven is recommended for 10-15 minutes or until the oven thermostat indicator light switches off to show the selected temperature has been reached.

When using a baking tray it should be placed centrally on the oven shelf with the short sides of the tray parallel to the sides of the oven. Do not use trays, tins or dishes larger than 380 mm (15") long, 356 mm (14") wide, as cooking results may be impaired.

Food	Thermostat setting °C	Shelf Position (Counted from Bottom)	Cooking Time
Small cakes (12 on tray)	195	3	20 - 30 mins.
Victoria sandwich (2x7"/180mm)	190	3	25 - 35 mins.
Swiss roll or whisked sponge	200	3	20 - 25 mins.
Fruit cake (8"/205mm)	155	2	2 - 3 hours.
Scones	260	3	10 - 20 mins.
Meringues	95	2	2 - 3 hours.
Shortcrust Pastry	210	3	25 - 45 mins. depending
Puff or Flaky Pastry	220	2	20 - 35 mins. upon
Choux Pastry	220	3	25 - 35 mins. dish
Biscuits	200/220	3	15 - 25 mins. depending upon type
Bread	250	2	30 - 40 mins.
Milk pudding	165	2	1 H - 2 hours.
Pizza	270	3	25 mins.
Lasagne	170	3	75 mins.
Oven noodles	160	3	75 mins.
BEEF on bone & crusty (rare) (medium) (well done)	270 rare	3	12 mins. per 1/b (500 g) plus 12 mins.
	220 °C	3	15 mins. per 1/b (500 g) plus 15 mins.
	220 °C	3	20 mins. per 1/b (500 g) plus 20 mins.
	180 °C	3	25 mins. per 1/b (500 g) plus 15 mins.
LAMB on bone	220 °C	3	20 mins. per 1/b (500 g) plus 20 mins.
	170 °C	3	27 mins. per 1/b (500 g) plus 27 mins.
Boned and rolled	220 °C	3	25 mins. per 1/b (500 g) plus 25 mins.
	170 °C	3	35 mins. per 1/b (500 g) plus 20 mins.
PORK on bone	220 °C	3	25 mins. per 1/b (500 g) plus 25 mins.
Boned and roller	180 °C	3	30-35 mins. per 1/b (500 g) plus 35 mins.
VEAL on bone	220 °C	3	25 mins. per 1/b (500 g) plus 25 mins.
Boned and roller	220 °C	3	30 mins. per 1/b (500 g) plus 30 mins.
CHICKEN	220 °C	3	20 mins. per 1/b (500 g) plus 20 mins.
	170 °C	3	25 mins. per 1/b (500 g) plus 25 mins.
TURKEY	220 °C	3	20 mins. per 1/b (500 g)
	170 °C	3	25 mins. per 1/b (500 g)
DUCK	220 °C	3	20 mins. per 1/b (500 g)
	170 °C	3	25 mins. per 1/b (500 g)
GOOSE	220 °C	3	20 mins. per 1/b (500 g) plus 20

PLATE WARMING

Ovenproof plates and dishes may be warmed in the oven on a low temperature setting. Remember do not place items directly into the oven base.

Warning: do not use foil to cover the oven shelves, or any part of the oven interior including the oven base. Foil should only be used to cover food and cooking dishes. Always place items which may boil over (e.g. fruit pies) on a baking tray to prevent spillage burning onto the oven base. Foil used improperly is frequent cause of oven problems and painful accidents. Avoid letting grease deposit collect around the upper heating element: it will cause smoking and may start a fire.

Remember do not place pan or items directly onto the oven base. Never leave unit unattended at high heat settings. Boil over causes smoking and greasy spill over that may start a fire.

If a grease fire should occur in a pan put out the flame by placing a lid on the pan. Do not throw water on a grease fire.

GUIDE FOR FORCED CONVECTION COOKING

(Back rolled electric element with fan)

The accessories provided with the oven can be slotted in at 5 positions: the following guide concerns cooking times and thermostat settings using N. 2 shelves on the same time (in position N. 2 and N. 4). Cooked results are a matter of personal preference and may easily be adjusted to suit individual requirements by slight adjustment of the temperature and/or cooking time, or when using more or less shelves in the same time. Preheating of the oven is recommended for 10-15 minutes or until the oven thermostat indicator light switches off to show the selected temperature has been reached.

When using a baking tray it should be placed centrally on the oven shelf with the short sides of the tray parallel to the sides of the oven. Do not use trays, tins or dishes larger than 380mm (15") long, 356 mm (14") wide, as cooking results may be impaired.

Food	Thermostat setting °C	Cooking Time
Small cakes (12 on tray)	175	15-25 mins.
Victoria sandwich (2x7"/180mm)	170	20-30 mins.
Swiss roll or whisked sponge	180	15-20 mins.
Fruit cake (8"/205mm)	135	1 H - 2 H hours.
Scones	210	8-15 mins.
Meringues	80	1 H - 2 H hours.
Shortcrust Pastry	190	20-40 mins. depending
Puff or Flaky Pastry	200	15-30 mins. upon
Choux Pastry	200	20-30 mins. dish
Biscuits	170/180	10-20 mins. depending upon type
Bread	200/220	25-35 mins.
Milk pudding	150	1 H - 2 hours.
Pizza	250	20 mins.
Lasagne	165	60 mins.
Oven noodles	150	60 mins.
BEEF on bone	230 rare & crusty	9 mins. per 1/b (500 g) plus 9 mins.
BEEF on bone	190 °C (rare)	15 mins. per 1/b (500 g) plus 8 mins.
	190 °C (medium)	20 mins. per 1/b (500 g) plus 10 mins.
	160 °C (well done)	25 mins. per 1/b (500 g) plus 8 mins.
Boned and rolled	190 °C (rare)	20 mins. per 1/b (500 g) plus 10 mins.
	190 °C (medium)	25 mins. per 1/b (500 g) plus 15 mins.
	160 °C (well done)	30 mins. per 1/b (500 g) plus 8 mins.
LAMB on bone	190 °C	20 mins. per 1/b (500 g) plus 10 mins.
	155 °C	27 mins. per 1/b (500 g) plus 14 mins.
Boned and rolled	190 °C	25 mins. per 1/b (500 g) plus 14 mins.
	155 °C	25 mins. per 1/b (500 g) plus 14 mins.
PORK on bone	200 °C	25 mins. per 1/b (500 g) plus 14 mins.
Boned and roller	160 °C	30-35 mins. per 1/b (500 g) plus 18 mins.
VEAL on bone	200 °C	25 mins. per 1/b (500 g) plus 14 mins.
Boned and roller	200 °C	30 mins. per 1/b (500 g) plus 14 mins.
CHICKEN	200 °C	20 mins. per 1/b (500 g) plus 10 mins.
	155 °C	25 mins. per 1/b (500 g) plus 13 mins.
TURKEY	200 °C	18 mins. per 1/b (500 g) plus 14 mins.
	155 °C	23 mins. per 1/b (500 g)
DUCK	200 °C	18 mins. per 1/b (500 g)
	155 °C	23 mins. per 1/b (500 g)
GOOSE	180 °C	18 mins. per 1/b (500 g) plus 20 mins.

USE OF THE ELECTRIC GRILL

USING THE GRILL

Turn the oven knob to the right and place it on the grill position .

The grill pan should be located on the top oven shelf position. Some models are provided with two detachable grill pan handles which are engaged over the front edge of the pan between the indentations provided. A wire grid is supplied. The grill pan handles should be removed from the grill pan during the grilling operation and only fitted for removal or insertion of the grill pan particularly when hot. Always preheat the grill on full for 3-5 minutes before inserting the food.

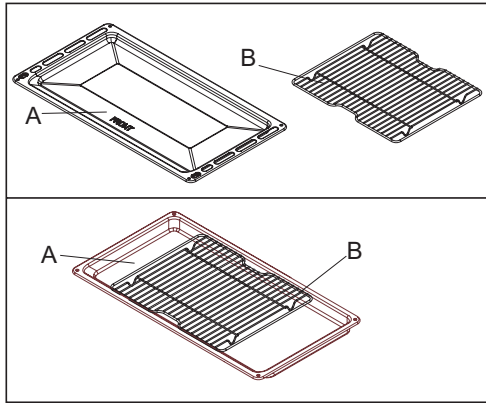

The user can change the shelves, depending on his personal wishes and on the different food. Preheat the oven 5 minutes before introducing the food.

Warning:

Do not place fatty foods too close to the grill and never leave the grill unattended. If fatty foods are grilled, or roasting has been cooked in the oven at a high temperature the grill element may smoke. This is not dangerous and the smoke is caused by the fat burning off when the grill element is hot. Leave the grill element on until the smoking has stopped then use as normal. If a grease fire should occur in a pan put out the flame by placing a lid on the pan. Do not throw water on a grease fire.

Oven Shelves

The shelves are designed with stop-locks so when placed correctly on the shelf supports, they will stop before coming completely out of the oven and will not tilt when you are removing food from them or placing food on them.

When placing cookware on a shelf, pull the shelf out to the bump on the shelf support. Place the cookware on the shelf, then slide the shelf back into the oven. This will eliminate reaching into the hot oven.

To remove the shelves from the oven, pull them forward you, tilt front end upward and pull them out.

To replace, do it in the opposite manner as before.

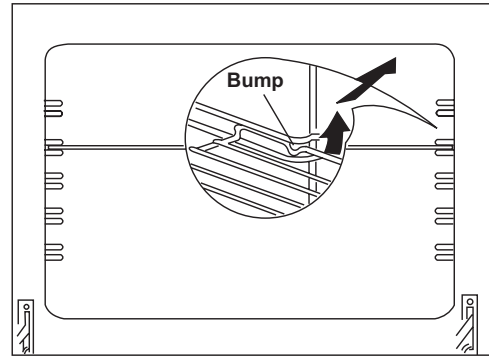

Install shelves by locating them in the horizontal guide rails on the oven walls. The raised portion of the shelf is to be facing the rear wall of the oven.

Sliding runners



Note: the sliding runners can be placed at levels 1 - 2 - 3 - 4 only (fig. 4).

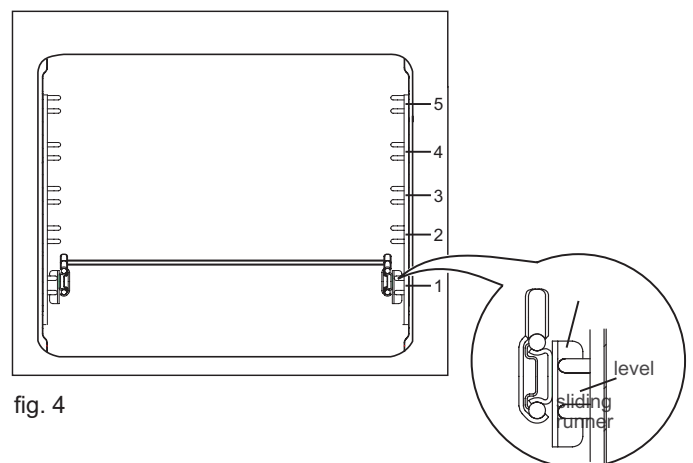

fig. 4

CLEANING

Before cleaning the appliance, close the gas stopcock and unplug appliance or disconnect power at the main circuit breaker of the electrical system.

Do not clean the appliance surfaces when still hot.

Always clean off spillage as quickly as possible to prevent burning on which will make removal more difficult. Wash with a clean cloth soaked in hot soapy water, rinse and dry with a soft cloth.

DO NOT USE ABRASIVES. CAUSTIC PASTES OR SPRAYS. COARSE CLEANING PADS OR POWDERS. DO NOT USE EXCESSIVE WATER WHEN CLEANING YOUR OVEN IN ORDER TO AVOID WATER PRESSING THROUGH CLEFTS INTO THE BACK OF CONTROLS PANEL OR OF THE UNIT.

NOTE: A steam cleaner is not to be used for cleaning this appliance .

Pan supports and burners

The burner heads can be removed for cleaning.

NB Do not drop hot burner caps in cold water.

Because of the rapid cooling they might get damaged.

Lift off and soak for about 10 minutes in hot water with a little detergent. After having cleaned and washed them, dry them carefully.

Make sure that no burner holes are clogged.

Clean the burners once a week or more frequently if necessary.

Make sure you have reassembled the burners correctly.

Pan supports can be washed by hand or in a dishwasher.

Remember to remove rubber feet (if fitted) prior to washing.

Refit them afterwards.

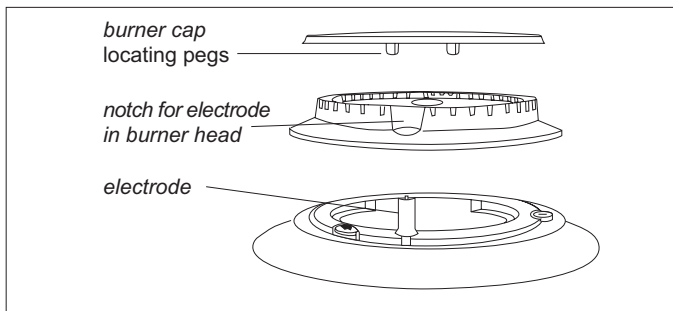

For a triple crown burner, make sure head "C" and covers "A" and "B" are properly placed on their seats as figure 4 and not off-centered as in figure 5.

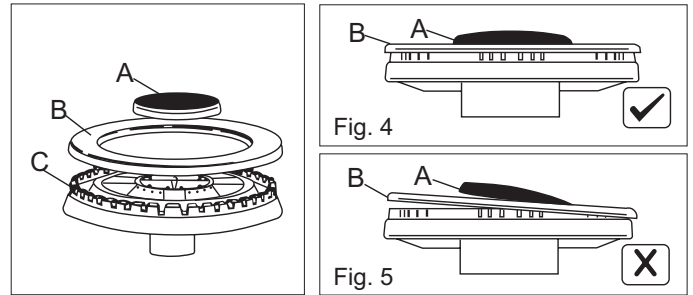

Daily

Regular wiping down directly after use prevents dirt from burning on. Clean the appliance with water and a detergent or all purpose cleaner.

Avoid using too much water to prevent it entering the burner or ventilation openings.

Oven accessories (shelves, trays etc) should be washed in mild detergent solution and should not be treated with abrasives. The oven interior panels should be cleaned with mild detergent solution, mild cream cleaners or a moist soap pad.

Interior: the oven shelf carriers and the back fan cover can be removed for easier cleaning. To do this, remove all the shelves and spring off the side carriers (Fig. 6 - 7). Replace in a similar manner.

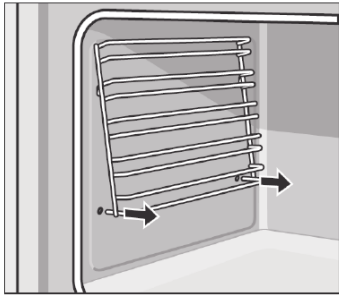

Fig. 6

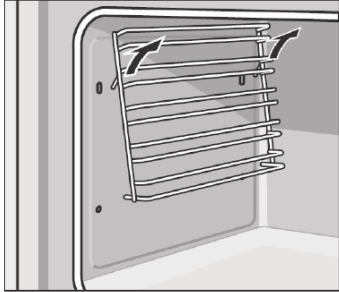

Fig. 7

Removal of oven door

In-depth cleaning of the oven becomes more convenient if the door is removed following the instructions below:

- 1 open the oven door completely.
- 2 flip the hinge hooks "A" outwards (see fig. 9B).
- 3 shut the oven door slowly until it reaches hooks "A", making sure these are locked into slots "B" of the oven door, as shown in fig. 9C. Remove the glass Fig. 9A (only for models where present).
- 4 Using both hands, push the oven door lightly inwards, to enable the door hinges "C" to come away from the slots "D" (see fig. 9D) and pull the door towards you until it is released from the oven.

After cleaning it, reposition it correctly following the above steps in the reverse order and flipping hooks "A" inwards before you shut the oven door (fig. 9E).

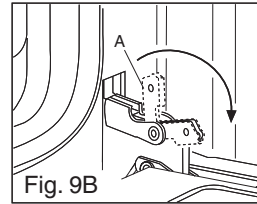

Fig. 9B

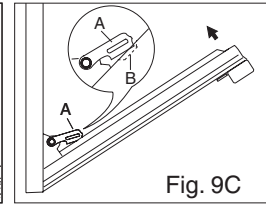

Fig. 9C

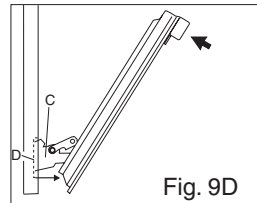

Fig. 9D

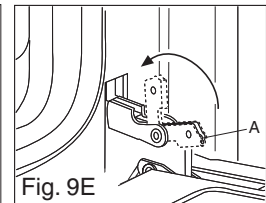

Fig. 9E

CAUTION:

Do not use rough or abrasive materials or sharp metal scrapers to clean the glass doors of the oven since they may scratch the surface and cause the glass to break.

IMPORTANT

Do not use excessive water when cleaning the oven and avoid water passing through the fan grill or ducts in the oven back. Avoid letting grease deposit collect around the upper heating element: it will cause smoking and may start a fire.

The interior glass of the oven

The interior glass of the oven door can be removed: with the door in a semi-open position, remove the screws A and B and the profile C as shown in fig. 9. Use both hands to remove the glass as shown in figures 9A.

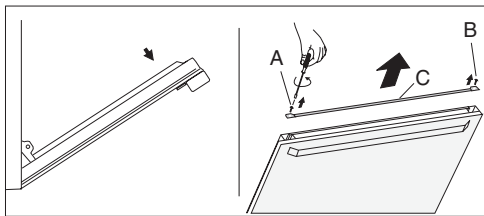

Fig. 9

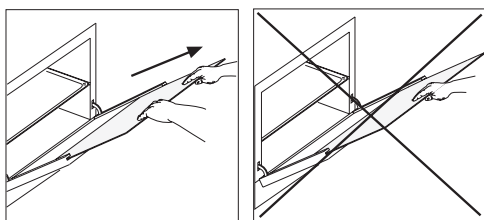

Fig. 9A

After cleaning, refit the glass by proceeding in reverse order.

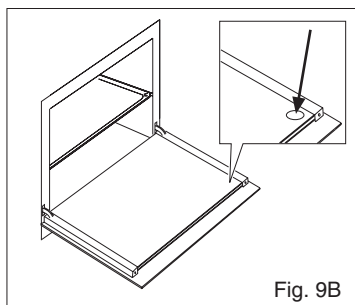

Fig. 9B

WARNING

The glasses must be reassembled correctly so that the symbol (R), printed on the surface, is in the 'lower-right corner when the door is completely open (Fig. 9B).

Be careful, because the glasses could shatter. In this case, do not use the oven anymore, and call the after-sales service.

WARNINGS

Before performing any repair or operation, switch the appliance off and close the gas tap.

The manufacturer declines all responsibility for any damage to persons, animals or things caused by failure to observe the rules indicated above. In case it is necessary to repair or replace the inside components, act as follows:

WARNINGS

Isolate the cooker from the electricity supply before attempting to replace the oven lamp.

The oven lamp used is of a special type withstanding high temperatures. To replace it, act as follows: disassemble the protecting glass (A) and replace the burnt lamp with one of the same type (Type E14 threaded clear lamp 230/240 V. 25 watt T 300°C). Reassemble the protecting glass.

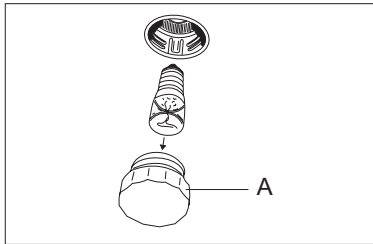

Disassembly of the worktop must only be done by a qualified service technician.

DISASSEMBLE OF WORK-TOP

In case it is necessary to repair or replace the inside components, act as follows:

Remove the grids, remove burners and flame-spreaders (see fig. 13), unscrew the visible screws "V" placed on the work-top (see fig. 14). Disassemble the work-top by unscrewing the rear screws "A" (see fig. 15A - 15B). In this way it is possible to lift the work-top and to reach the inside components.

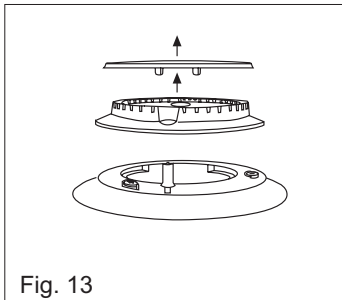

Fig. 13

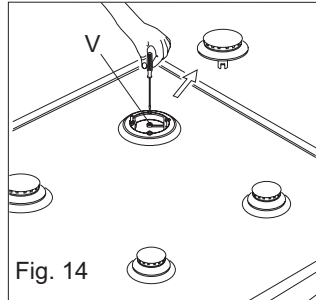

Fig. 14

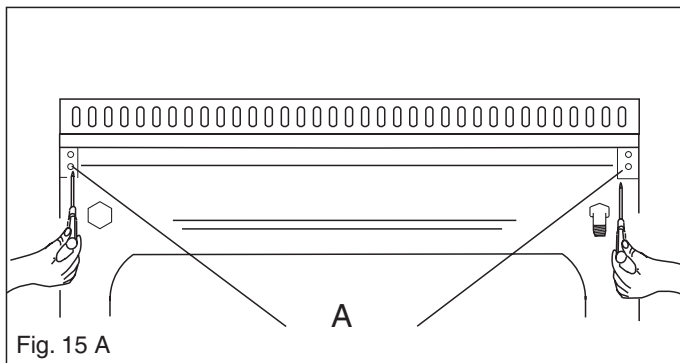

Fig. 15 A

SOME SAFETY POINT

Do not use the appliance as a space heater.

If you smell gas

Open a window. Do not use any electrical switches. Immediately extinguish naked flames. Isolate appliance from gas mains supplies via the isolation stopcock. Contact local gas authority or emergency services as appropriate. In the event of food fire. Isolate appliance from electric / gas mains supplies if safe to do so. Try to extinguish flames with the appropriate equipment (fire blanket or extinguishing foam). Do not use water on cooking fat / oil fires.

If in difficulty call emergency services.

- Do not store or use flammable products or aerosol containers near the hotplate or burners.
- Never flambe, under an extractor - even if the ventilator is switched off.
The high flames can cause fire.

For your safety and that of your children

- Do not store items that are attractive to children above or near the appliance.
 - Keep children well away from the appliance: do not forget that some parts of the appliance or of the pans become very hot and dangerous during use, and will take time to cool down.
 - When cooking, do not use clothes that could catch fire and cause serious injury.
 - Some "Wok" cooking pots are unstable. Check with the manufacturer before purchasing.
 - Avoid using unstable and misshapen pans which may tilt easily and pans with a very small base diameter, e.g. milk pans, single egg poachers. The minimum pan diameter recommended is 125mm (5"). Smaller pans will be unstable.
- Very large pans may cause walls or knobs to overheat. Using pans which are too big may deform the control knobs or discolour the walls. This is not covered by the guarantee.
- Carefully place all pans centrally over the burners.
 - Always position pan handles safely away from the front of the hotplate and out of danger, particularly from small children.
 - Never leave a chip pan unattended.
 - Pans and kettles with down turned base rims should not be used.
 - Simmering aids such as asbestos or mesh mats are NOT recommended. They will reduce burner performance and could damage the pan supports.
 - Commercially available foil spillage aids are unnecessary on this hotplate.

PROBLEM SOLVER

Any of the following are considered to be abnormal operation and may require servicing:

- Yellow tipping of the hob burner flame.
- Sooting up of cooking utensils.
- Burners not igniting properly.
- Burners failing to remain alight.
- Burners extinguished by oven door.
- Gas valves, which are difficult to turn.

Your Installer should be contacted if you have any problems with the installation.

Before you call a service engineer please check if the problem is something you could fix yourself. The cause of the problem is often a simple one.

THINGS TO TRY BEFORE CALLING FOR AN ENGINEER

Burner does not burn well

Is the burner dirty or damp? Try cleaning and/or drying the burner. Appliance not suitable for your gas type? Check the identification plate on the hotplate base.

Burner does not ignite

Do the burners spark when you press the ignition button? If not is the power on? See 'Checking the power supply' section further on. If the power supply is OK then there is probably something wrong with the ignition system.

Are the electrode or burner slots blocked by debris?

Is the burner dirty or damp? Try cleaning and/or drying the burner. Is the burner trim correctly located?

Are the burner caps correctly located?

Check that there is not a problem with your gas supply. You can do this by making sure that other gas appliances you may have are working.

Pan supports

Aluminium pans may cause a metallic marking on the pan supports which does not affect the durability of the enamel and may be cleaned off with a metal cleaner such as 'Brasso'.

Checking the power supply

First check the socket by trying out another piece of electrical equipment in it.

If that works, renew the fuse in the hotplate plug. Use a 10 amp fuse. If the fuse 'blows' again there is a fault on the hotplate. Do not use a fuse with a higher rating. Do not carry out other electrical work. Unplug the hotplate and tell your installer.

Power Failure

In the event of a failure in the electrical supply the hotplate burners may be lit using a match.

Ventilation

The use of a gas cooking appliance results in the production of heat and moisture in the room in which it is installed. Ensure that the kitchen is well ventilated: keep natural ventilation holes open or install a mechanical ventilation device, (mechanical extractor hood). Prolonged intensive use of the appliance may call for additional ventilation, for example opening a window, or more effective ventilation, for example increasing the level of mechanical ventilation where present. For more detail see the Installation Instructions.

OVEN DOES NOT WORK AT ALL

First, when the oven is equipped with timer, check appliance is not programmed to turn on later. If it is, turn to manual setting (i.e. hand symbol). If the button or scale on the timer remains in the automatic position after use, the power supply to the oven will be interrupted. Also, check your appliance is switched on at the mains. Next check for an unexpected power strike by switching on adjacent lights etc. Finally, check fuses and plug wiring. If all these prove satisfactory, call engineer.

LIGHT BULB DOESN'T COME ON

Check bulb for looseness or burned out bulb.

Note: bulb replacement is not covered by your guarantee.

SMOKE COMING FROM OVEN

If oven is still relatively new, this problem is invariably due to protective oil on elements. Otherwise, the answer may be oil or fat which has become deposited on the elements during cooking. In either event, continued use should burn away the residues. On future occasions, try to shield food with foil or keep it further away from element, particularly when grilling.

CLOCK/TIMER DOES NOT WORK

Check to be sure range cord is plugged into outlet completely. Check for a blown fuse or tripped circuit breaker. Check for power outage. Check step by step operating Instructions on previous pages.

If, after checking through this section, you cannot resolve your problem please call the number on the data plate fixed to the front cover of these instructions for service and spare parts.

When ordering please quote the appliance name, the colour variant and serial number.

This information can be found on the data plate sealed inside the front appliance drawer.

Maintenance schedule:

To ensure the appliance continues to operate at peak performance, we recommend a routine service call every 2 years for the life of the appliance.