

STOVAX



Regency *Free Standing Stove*

MODELS: 1000/1001/1002

Instructions for Use, Installation and Servicing

For use in Great Britain and Republic of Ireland



This appliance has been certified for use in countries other than those stated. To install this appliance in these countries, it is essential to obtain the translated instructions and in some cases the appliance will require modification. Contact Stovax for further information.

*Excludes 1002

IMPORTANT

This appliance will become hot whilst in operation, it is therefore recommended that a suitable guard should be used for the protection of young children, the elderly or infirm. Do not attempt to burn rubbish in this appliance.

**Please read these Instructions carefully before installation or use.
Keep them in a safe place for future reference and when servicing the fire.**

The commissioning sheet found on page 3 of these instructions should be completed by the Installer.

**COVERING THE FOLLOWING MODELS:
1000/1001/1002**

APPLIANCE COMMISSIONING CHECKLIST	3	COMMISSIONING	21
USER INSTRUCTIONS	4	MAINTENANCE & SERVICING	22
General Points	4	Annual Service	22
Using the appliance for the first time	6	Removal of Baffle & Grate	23
Recommended Fuels	6		
Lighting the appliance	7	BASIC SPARE PARTS LIST	23
Running the appliance	7	SERVICE RECORDS	24
Burning Tips	7	EC DECLARATION OF CONFORMITY	260
Ash Removal	8		
Over night burning	9		
Over-Firing	9		
Chimney Fire	9		
General Cleaning	9		
Chimney Sweeping	9		
Care of Appliance	10		
Seasonal Use	10		
Troubleshooting Tips	10		
INSTALLATION INSTRUCTIONS	11		
Technical Specifications	11		
Standard Features	11		
Packing List	11		
Dimensions	12		
SITE REQUIREMENTS	13		
Flue & Chimney	13		
Flue exit positions	14		
Hearth Dimensions	14		
Walls Next to Hearth	15		
PRE-INSTALLATION	16		
Ventilation	16		
Additional Ventilation	17		
INSTALLATION	18		
Legal Requirements	18		
Installing the Appliance	18		
Top Flue Installation	18		
Rear Flue Installation	19		
Fitting & Removal of Baffles	19		
Fitting & Removal of the Grate	20		
Additional Options	20		



This appliance has been approved by HETAS Ltd.

APPLIANCE COMMISSIONING CHECKLIST

To assist us in any guarantee claim please complete the following information:-

Stovax dealer appliance was purchased from

Name:

Address:

.....

Telephone number:

Essential Information - MUST be completed

Date installed:

Model Description:

Serial number:

Installation Engineer

Company name:

Address:

.....

Telephone number:

Commissioning Checks (to be completed and signed)

Is flue system correct for the appliance YES NO

Flue swept and soundness test complete YES NO

Smoke test completed on installed appliance YES NO

Spillage test completed YES NO

Use of appliance and operation of controls explained YES NO

Instruction book handed to customer YES NO

Signature:

Print name:

USER INSTRUCTIONS

1. GENERAL POINTS

- 1.1 **Before use of this appliance please read these instructions fully.**
- 1.2 **All local regulations, including those referring to national and European Standards need to be complied with when installing the appliance.**
- 1.3 Only use for domestic heating in accordance with these operating instructions.
- 1.4 You must burn only approved fuels. Do not use with liquid fuels or as an incinerator.
- 1.5 Appliance surfaces become very hot when in use. Use a suitable fireguard if young children, elderly or infirm persons are present.
Stovax offer firescreens, sparkguards and hearthgate systems for protection*. Your Stovax dealer can advise you about these products.
- 1.6 Do not place photographs, TV's, paintings, porcelain or other combustible items on the wall or near the appliance. Exposure to hot temperatures will cause damage.
- 1.7 Extractor fans or cooker hoods must not be placed in the same room or space as this can cause appliance to emit fumes into the room.
- 1.8 Do not obstruct inside or outside ventilation required for the safe use of this appliance.
- 1.9 Do not make unauthorised changes to the appliance.
- 1.10 The chimney must be swept at least once a year. See Section 12
- 1.11 **Do not connect, or share, the same flue or chimney system with another appliance.**

SERIAL NUMBER

- 1.11 This number is required when ordering spare parts or making warranty claims.
It is found on the appliance data plate, See Diagram 1

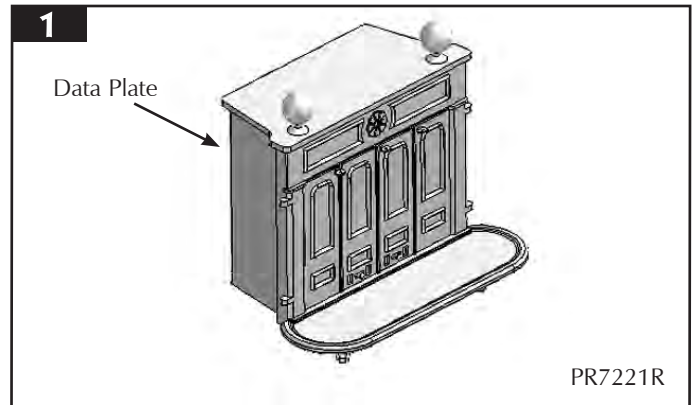

AIR CONTROLS

The Regency can be used as an open appliance or with the doors closed. When the doors are closed the air sliders at the bottom of the doors can give limited control of the airflow, See Diagram 2

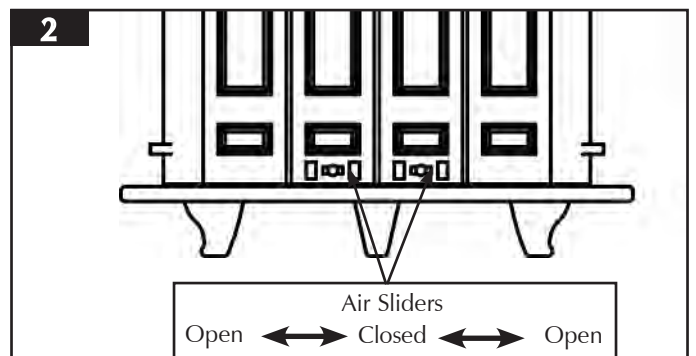

DOOR HANDLE

- 1.12 **Use a protective gloved hand to operate.**
See Diagram 4

DO NOT OPEN THE DOOR WITH BARE HANDS

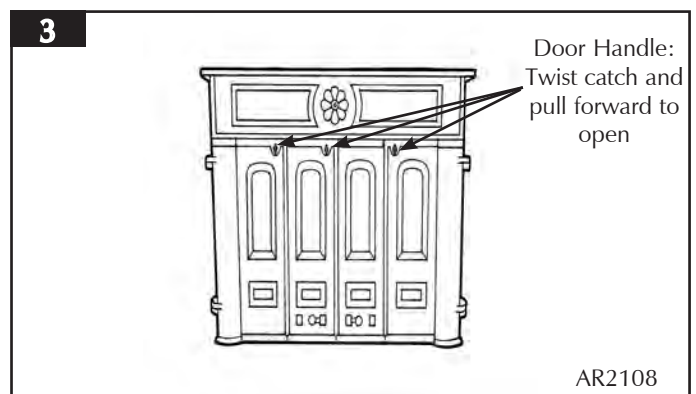

USER INSTRUCTIONS

Flue Adapter
Stovax Part No.
4819

(Not included with appliance)

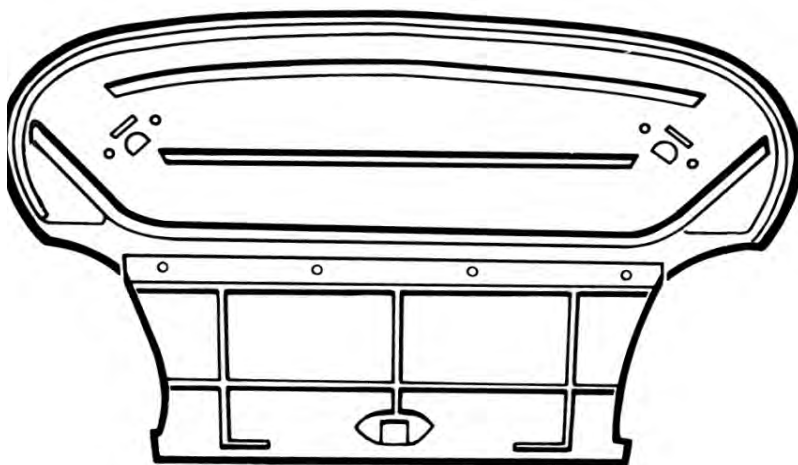
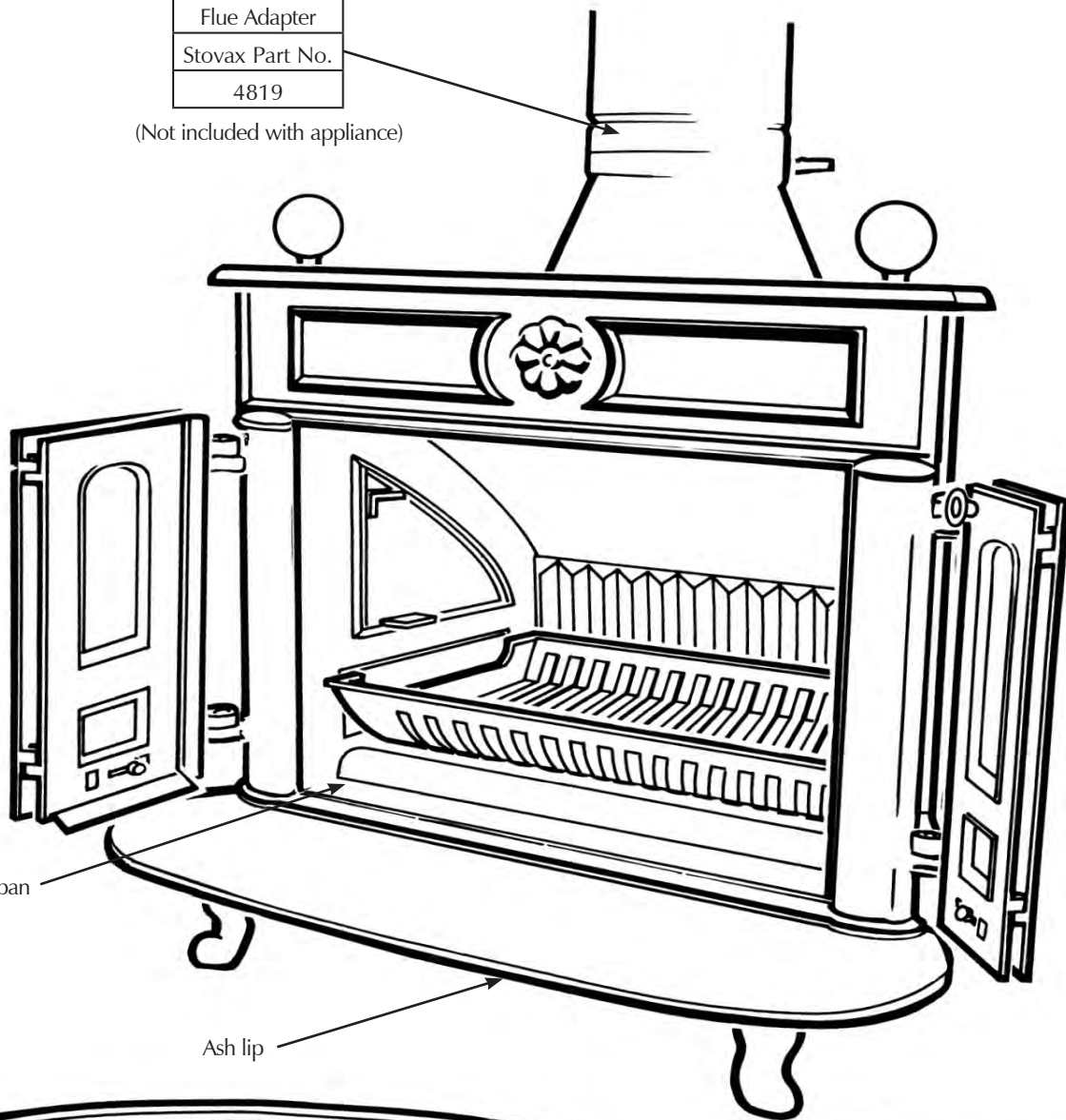

bottom view

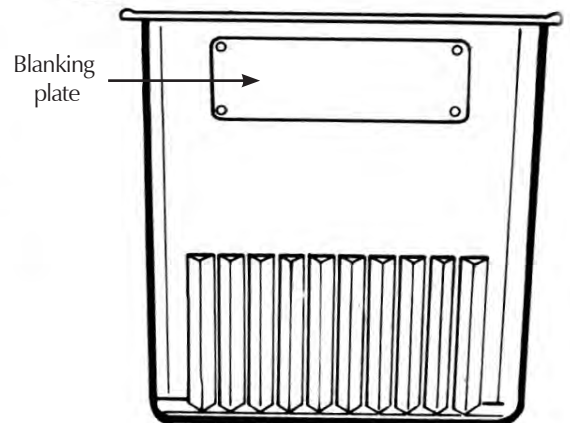

rear view

USER INSTRUCTIONS

WARNING

Properly installed, operated and maintained this appliance will not emit fumes into the room.

Occasional fumes from de-ashing and refuelling may occur.

Persistent fume emission is potentially dangerous and must not be tolerated.

If fume emission does persist:

- Open doors and windows to ventilate the room
- Allow fire to burn out or safely dispose of fuel from the appliance
- Check for chimney blockage and clean if required
- Do not attempt to relight until the cause of the emission has been identified and corrected
If necessary seek expert advice.

2. USING THE APPLIANCE FOR THE FIRST TIME

- 2.1 To allow the appliance to settle and fixing glues and paint to fully cure:
- Operate the appliance at a low output for first few days
- 2.2 **Do not touch the paint during the first period of use.**
- 2.3 During this time the appliance may give off some unpleasant odours:
- Keep the room well ventilated to avoid a build-up of fumes.

3. RECOMMENDED FUELS

3.1 Wood Logs:

- Burn only seasoned timber with a moisture content of less than 20%

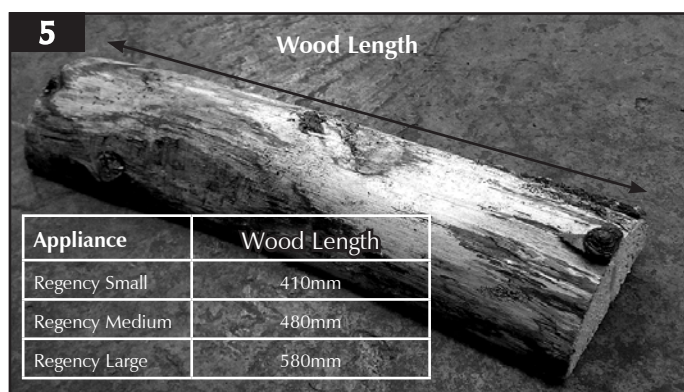

- Dry cut wood for 12 to 18 months before use
- Poor quality timber:
 - Causes low combustion efficiency
 - Produces harmful condensation

Do not burn construction timber, painted, impregnated / treated wood, manufactured board products or pallet wood.

3.2 Solid fuel:

- Burn only anthracite or manufactured briquette smokeless fuels listed as suitable for use with open heating appliances

Do not burn bituminous coal, 'petro-coke' or other petroleum based fuels as this will invalidate the product guarantee.

3.3 Fuel consumption.

As tested at nominal heat output to the requirements of EN 13229: 2001 for intermittent operation:

Description	Fuel Consumption	
	Kg/hour Wood	Kg/hour Briquette Smokeless fuel
1000 Small Regency	4.4	1.3
1001 Medium Regency	6.8	1.5
1002 Large Regency	N/A	N/A

3.4 For advice on suitable solid fuels:*

- Contact your local approved coal merchant

A number of factors can affect the performance of the appliance. See *Section 8* for details.

*In the U.K:

- Ring the Solid Fuel Association advice line on 0845 601 4406 for details
- Visit their web site at www.solidfuel.co.uk

USER INSTRUCTIONS

4. LIGHTING THE APPLIANCE

4.1 For best results:

- Fully open the doors
- Place firelighters or paper and dry kindling wood on the grate
- Light the paper or firelighters, See Diagram 6



• To increase the flue draught the doors may be closed
This will help the fire to establish.

• Add larger pieces of wood
Too many logs may smother the fire.

Do not load fuel higher than the sides of the fire grate.
See Diagram 8

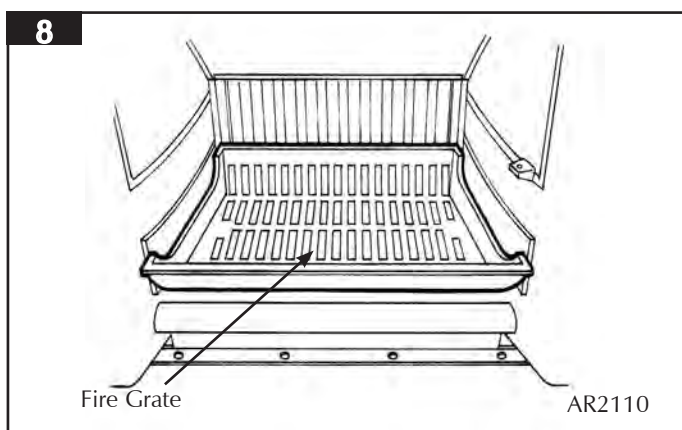

4.2 As the fire becomes established the appliance may be operated with the doors open or closed. Operating the appliance with the doors closed the air controls at the bottom of the doors may be used to give limited combustion control.

5. RUNNING THE APPLIANCE

5.1 **Burning Wood (with Multi-fuel grate fitted):**

- Wood burns best on a bed of ash

- Open the doors fully for a few minutes before re-fuelling
- Rake the embers evenly over the fire bed
- Burn new logs at high output for a few minutes before adjusting the **Air Inlet controls**. Refuel little and often for clean, efficient burning.
- Experience establishes settings to suit personal preferences
- When in use, burning the appliance at high output for a short period also reduces tars and creosote.

5.2 **Burning Solid fuel (Multi-fuel appliances only):**

- Open the doors fully for a few minutes before re-fuelling
- Rake the embers evenly over the fire bed before adding new fuel
- Refuel little and often for clean, efficient burning
- Experience establishes settings to suit personal preferences
- When in use, burning the appliance at high output for a short period also reduces tars and creosote
It is not recommended to burn large loads of fuel on low settings for long periods of time as this causes a large build up of tars and creosotes.

6. BURNING TIPS

6.1 **Fuel Quality (Wood)**

Use wood with a moisture content of less than 20%. Seasoned logs have the bark beginning to lift and peel away and cracks radiating from the centre. They feel lighter than fresh cut wood of a similar size and sound hollow when struck against each other. Logs should not feel damp or have moss and fungal growths.

Symptoms related to wet wood:

- Difficulty starting and keeping a fire burning well
- Smoke and small flames
- Dirty firebricks
- Rapid creosote build-up in the chimney
- Low heat output
- Short burn times, excessive fuel consumption and blue/grey smoke from the chimney

- Burn at high output for a short period to avoid large build-ups of tars and creosote within the appliance and the flue system
- Use Stovax Protector chimney cleaner to reduce this problem

6.2 **Fuel Quality (Solid Fuel)**

- Use recommended solid fuels approved for use with closed appliances.
- Symptoms related to unsuitable fuels include:
 - Difficulty starting and keeping a fire burning well

USER INSTRUCTIONS

- Smoke and small flames
- Dirty firebricks
- Short life span for grate, baffles and internal firebricks

6.3 Air inlets puffing smoke

Combustion gases build up in the firebox and ignite as small explosions, causing smoke to puff out of the air inlets and other openings. This occurs if the air controls are shut soon after adding new fuel to a very hot fire. Stop by opening the air controls to increase combustion air and burning rate.

6.4 Flue Draught

The chimney has two main functions:

- 1) To safely remove the smoke, gases and fumes from the house.
- 2) To provide a sufficient amount of draught (suction) in the appliance ensuring the fire keeps burning.

Draught is caused by the rising hot air in the chimney when the appliance is lit.

Symptoms of poor performance related to flue draught include:

- Excessive fuel consumption (high flue draught)
- Poor burning control, overheating (high flue draught)
- Wind noise from air controls (high flue draught)
- Difficulty getting a fire going and keeping it burning well (low flue draught)
- Low heat output (low flue draught)
- Smoke entering room when doors opened (low flue draught)

The construction, position, size and height of the chimney all affect the performance of the flue draught.

Other factors effecting the flue draught include:

- Trees or other buildings nearby causing turbulence
- High and gusty winds
- Outside temperature
- Outside weather conditions
- Incorrect additional ventilation to building
- Blocked flue / chimney

For advice on the correction of persistent flue problems consult a qualified solid fuel heating engineer before continuing to use the appliance.

6.5 Weather conditions

The weather conditions outside the building can effect the burning performance of the appliance. These could include:

Weather Conditions	Problem	Effect
Windy days	Buildings/Obstacles cause turbulent air around chimney.	Smoky Appliance
Calm days	Oversized Chimney.	Smoky Appliance
Damp / Rainy days	Flue temperature not hot enough. Rain water inside chimney.	Lighting and burning problems

To reduce these problems:

- Use good quality kindling wood to start the fire
- Burn initially at a high temperature for a short period
- Fit a rain cowl to the chimney

Your installer should advise you on possible solutions.

If the appliance emits smoke into the room continuously:

- Close the air controls and allow the appliance to go out
- Ventilate the room to clear the fumes

Do not re-light the appliance until the problem is solved.

7. ASH REMOVAL

7.1 All Fuels:

- Open Doors, See Diagram 11

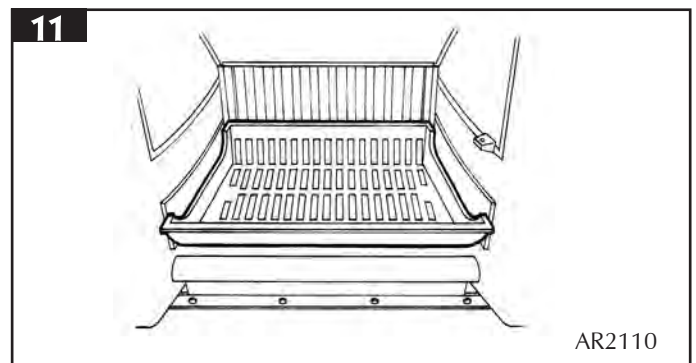

- Remove Ashpan, See Diagram 12

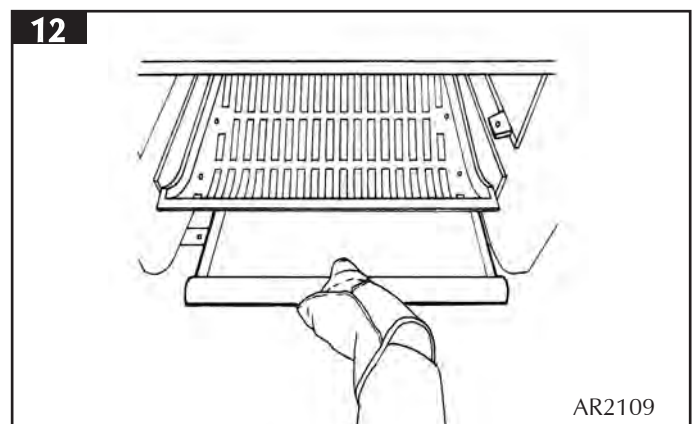

USER INSTRUCTIONS

7.3 Remove Ashpan carefully. Heat can remain long after use, See Diagram 12

- Use gloves, or place the ash into a Stovax Ash Caddy (Stovax Part No. 4227)
- Remove ash at least once every week when burning wood
- Do not place hot ash in a bin made from plastic or any other combustible material.

8. EXTENDED BURNING

8.1 It is possible to lengthen the re-fuelling period. In order to do this:

- De-ash prior to final refuelling
- Close the doors
- Close air controls
- Use smokeless fuel or small, thick logs depending on fuel desired

9. OVER-FIRING

9.1 Do not over-fill with fuel or use at maximum output for long periods or over-firing can occur. If the flue pipe, flue collar or top plate glow red the appliance is over-firing:

- Close the air controls to reduce the output

9.2 Over-firing can cause permanent damage to the appliance.

10. CHIMNEY FIRE

10.1 If a chimney fire occurs:

- Shut all air controls immediately
- Evacuate the building
- Call the fire brigade
- Do not re-enter the building until it is confirmed safe

10.2 **Do not use the appliance after a chimney fire until:**

- It has been inspected by a registered installer, confirming the appliance is safe to use***
- The chimney system inspected and swept by a chimney sweep, confirming the system is structurally sound and free from obstruction before re-use.**
- It is repaired as required before re-use.** Use only genuine Stovax replacement parts to keep your appliance in safe and efficient working order.

11. GENERAL CLEANING

11.1 **Allow appliance to cool thoroughly to avoid risk of burns:**

- Clean regularly, according to the level of use
- Give attention to the baffle system, flue ways and removing ash

Regular cleaning and maintenance will help give many years of safe use.

- Clean matt black appliances using Stovax Collodial black or Stovax Grate Polish

To refresh painted finishes use Stovax Thermolac paint.

- Do not use aerosol sprays near an operating appliance

Wipe dry with a soft clean cloth before re-lighting. Do not leave unit without drying, as this may cause rust.

Do not use abrasive cleaner or cleaning pads to clean enamel finishes.

12. CHIMNEY SWEEPING

12.1 To maintain safe and efficient use of the appliance the chimney/flue must be inspected and swept at least once a year by a qualified chimney sweep.*

If the appliance is used continuously throughout the year or it is used to burn wood or smokeless fuel, more frequent sweeping is recommended.

The best time to have the chimney swept is at the start of the heating season.

The above applies even if burning smokeless fuels.

12.2 The chimney, any connecting flue pipe and the appliance flue ways if incorporated, must be regularly cleaned.

12.3 Ensure adequate access to cleaning doors where it is not possible to sweep through the chimney.

12.4 If the chimney is believed to have previously served an open fire the chimney must be swept a second time within a month of regular use after installation.

In the U.K:

* registered with HETAS (GB only)/INFO (Republic of Ireland only)

**This should be done by a NACS registered (UK only)/INFO registered (Eire only) chimney sweep, who will issue you with a certificate.

USER INSTRUCTIONS

13. CARE OF APPLIANCE

Stovax has a range of cleaning and maintenance products and accessories to keep your appliance in good working condition. Your Stovax retailer can provide full details but here is a brief list of useful items:

Product Code	Description
3047	Extra long matches
5039	Gas lighter
4052	Log basket
3048	Wood sling - for easy carrying of logs
3016	Log tongs
4027	Extra long protective gloves
5038	Hearthgate - 5 section (for areas 1780x610mm)
5044	Hearthgate - 7 section (for areas 1780x405mm)
4227	Ash caddy - 382x102x306mm
4228	Ash caddy - 446x102x306mm
4229	Ash caddy - 382x102x459mm
4230	Ash caddy - 637x127x408mm
4231	Ash caddy - 306x178x459mm
2091	Ashclean vacuum cleaner attachment
4232	Steel brush

Your retailer can provide genuine spare parts such as replacement glass, door sealing rope and fire bricks when required. An annual service by a competent engineer is recommended to keep your appliance in best possible condition.



14. SEASONAL USE

- 14.1 Clean and service the appliance if it is not used during the warmer periods of the year as detailed in the *Maintenance and Servicing* section
- 14.2 Set the air controls 50% open to keep the appliance ventilated and stop the build-up of any moisture inside.
- 14.3 Before re-lighting the appliance:
 - Remove the baffles
 - Clear any debris that may have accumulated
 - Check the flue is clear of any blockages

15. TROUBLESHOOTING TIPS

15.1 Appliance is producing tar:

This is identified by:

- A very strong pungent smell shortly after the appliance is lit and heats up

- Thick, brown and sticky tar oozes from the pipe joints

This is caused by burning damp wood and burning your appliance at too low a temperature;

- Use well seasoned wood and operate the appliance in the ideal temperature range

Tar is a major cause of chimney fires - if you experience problems with tar build up consult a chimney sweep before continued use of your appliance.

Ideal working temperature range is 130°C and 240°C (270°F – 465°F). Failing to close down the primary air control once the appliance has heated up to this range may cause the appliance to over-fire and to exceed the ideal temperature range. Over-firing can cause permanent damage to the appliance and invalidates your warranty.

TECHNICAL SPECIFICATION

REGENCY 1000/1001/1002

Model Regency 1000/1001/1002*			Small Regency	Medium Regency	* Large Regency
Nominal Heat Output	Wood	kW	5	12	12
	Solid Fuel	kW	4	5	6
Flue Draught at Nominal Heat Output	All Fuels	mm	1.25	1.25	1.25
		inch Wg	0.05	0.05	0.05
Flue Gas Mass Flow	Wood	g/s	39	42	N/A
	Solid Fuel	g/s	45	45	N/A
Flue Gas Temperature at Spigot/Socket	Wood	°C	211	331	N/A
	Solid Fuel	°C	211	331	N/A
Flue Outlet Size (Top or Rear Option)		mm	200	200	200
		inch	8	8	8
Weight		kg	114	136	150

Recommended Fuels	Wood	Seasoned wood (less than 20% moisture content)
	Solid Fuel	Briquette smokeless fuel suitable for open appliances. (Homefire - Supertherm)

As tested to the requirements of EN 13229 for intermittent operation with doors open *(Excludes 1002).

1. STANDARD FEATURES

- Multi-fuel kit
- Top or rear flue exit option

2. PACKING LIST

- Instructions
- Guarantee card
- Flue collar
- 3 x Legs
- Blanking Plate
- Fixing Screws

TECHNICAL SPECIFICATION

REGENCY DIMENSIONS

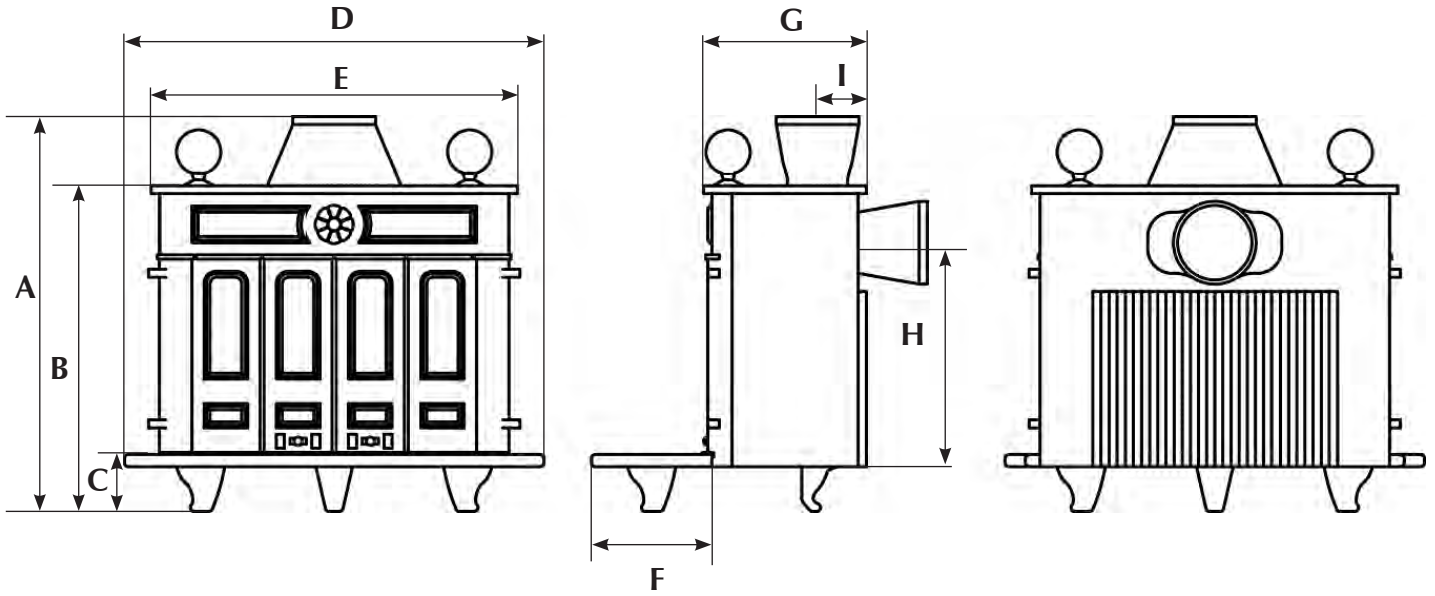

PR7215R

Description	Model	A	B	C	D	E	F	G	H	I
Small Regency	1000	930mm	760mm	140mm	850mm	740mm	296mm	350mm	650mm	120mm
Medium Regency	1001	960mm	800mm	140mm	950mm	840mm	296mm	400mm	690mm	120mm
Large Regency	1002	960mm	800mm	140mm	1050mm	930mm	296mm	400mm	690mm	120mm

All dimensions in mm. (25.4 mm = 1")

SITE REQUIREMENTS

1. FLUE OR CHIMNEY

- 1.1 The flue or chimney system must be in good condition. It must be inspected by a competent person and passed for use with the appliance before installation

Products of combustion entering the room can cause serious health risks.

- 1.2 You must check the following:

— The construction of the masonry chimneys, flue block chimneys and connecting flue pipe system must meet the requirements of the Building Regulations†

— A flexible flue liner system can be used if certified for use with solid fuel systems and installation complies with manufacturer's instructions and Building Regulations. The flue liner must be replaced when an appliance is replaced unless proven to be recently installed and in good condition.

— If it is necessary to fit a register plate it must conform to the Building Regulations†

— The minimum height of the flue or chimney must be 4.5m from the hearth to the top of the flue, with no horizontal sections, a maximum of 4 bends with angles of less than 45 degrees

— Ensure the connecting flue pipe it kept a suitable distance from any combustible material and does not form part of the supporting structure of the building

— Make provision to remove the appliance without the need to dismantle the chimney

— Any existing flue must be confirmed as suitable for the new intended use as defined in the Building Regulations

— The flue or chimney systems must be inspected and swept to confirm the system is structurally sound and free from obstructions**

— If the chimney is believe to have previously served an open fire the chimney must be swept a second time within a month of regular use after installation to clear any soots falls that may occurred due to difference in combustion levels.

— The flue exit from the building must comply with local building control rules.†

— Do not connect or share the flue or chimney system with another heating appliance

- 1.3 Do not connect to systems containing large voids or over 230mm square.
- 1.4 You must provide suitable access to enable the collection and removal of debris.

- 1.5 You must sweep and inspect the flue when the appliance is installed.

- 1.6 You must check the flue draught with all windows and doors closed and any extraction fans in this or adjoining rooms running at maximum speed. (See next section for additional ventilation requirements)

Max. Draught = 2.0mm Wg

Min. Draught = 1.0mm Wg

In the U.K:

*BS 6461: Part 1, and the requirements of Building Regulations

**This should be done by a NACS registered (UK only)/ INFO registered (Eire only) chimney sweep, who will issue you with a certificate.

† Building Regulations Document J

Flue Plate:

Where a hearth, fireplace, flue or chimney is provided or extended (including cases where a flue is provided as part of refurbishment work), information essential to the correct appliance and use of these should be permanently posted in the building, to meet Requirement J4 of the Building Regulations (England and Wales), F3.12 (Scotland).

† Building Regulations Document J

Additional:

A new factory made system that complies to EN 1856; Part 1 can be used providing installation is to the requirements of:

- i) BS 7566 Parts 1 -4
- ii) the manufacturer's instructions
- iii) Building Regulations.

For a guide containing information on Chimneys and Flues contact:

The British Flue & Chimney Manufacturers' Association,
FETA
2 Waltham Court
Milley Lane
Hare Hatch
Reading
Berkshire RG10 9TH

Tel: 0118 9403416

e-mail: info@feta.co.uk

SITE REQUIREMENTS

1. FLUE OUTLET POSITIONS

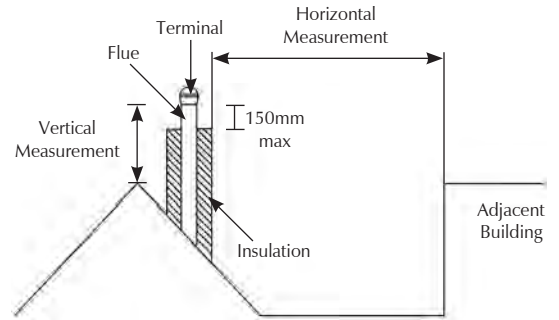
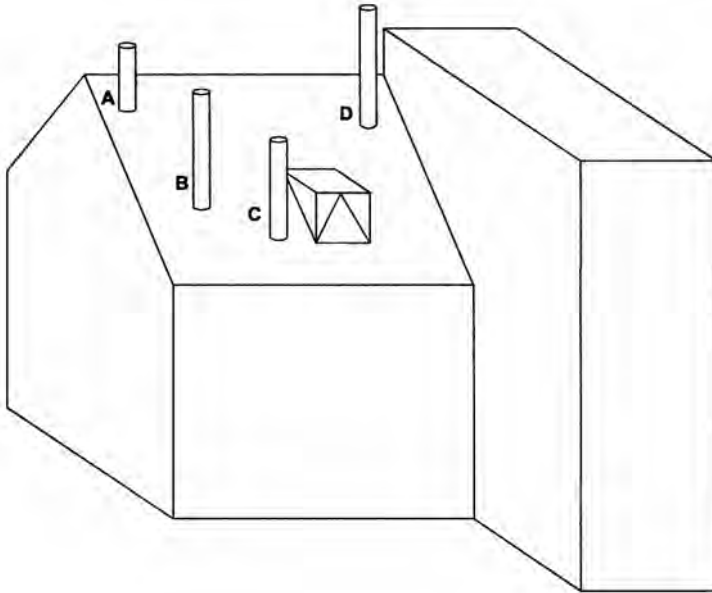

The vertical measurement is the lowest from either the point of discharge or 150mm above insulation.

	Position On Roof	Minimum Clearances
A	On ridge or within 600mm	600mm above ridge
B	Elsewhere on roof	2300mm horizontally from roof surface and: a) 1000mm above highest point of flue exit from roof or b) as high as the ridge
C	On pitched, within 2300mm horizontally to openable window, dormer	1000mm above top of opening
D	Within 2300mm of another building	600mm above top of building

IMPORTANT: Seek specialist advice if installing in a dwelling with a thatched roof

2. HEARTH DIMENSIONS

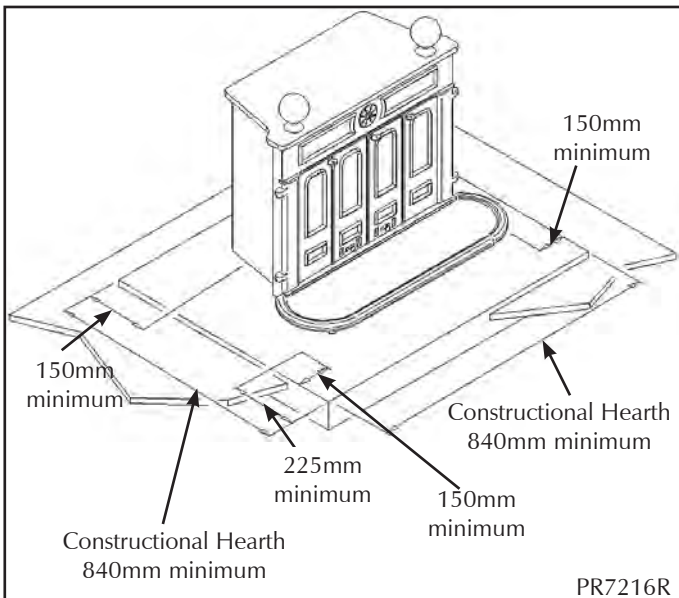

- 2.1 The appliance must stand on a non-combustible constructional hearth which is at least 125mm thick with the minimum dimensions as shown in diagram.
- 2.2 The building must have a suitable load-bearing capacity for the hearth and appliance.
 - Consult a structural engineer for advice before proceeding
- 2.3 When fitting into an existing hearth check:
 - That the appliance complies with current construction regulations and is at least the minimum sizes shown
- 2.4 If there is no existing fireplace or chimney it is possible to construct a suitable non-combustible housing and hearth setting. The flue must be installed in accordance with all local and national regulations and current rules in force .
 - Check if adding a new chimney to your property requires planning permission

SITE REQUIREMENTS

3. WALLS NEXT TO A HEARTH

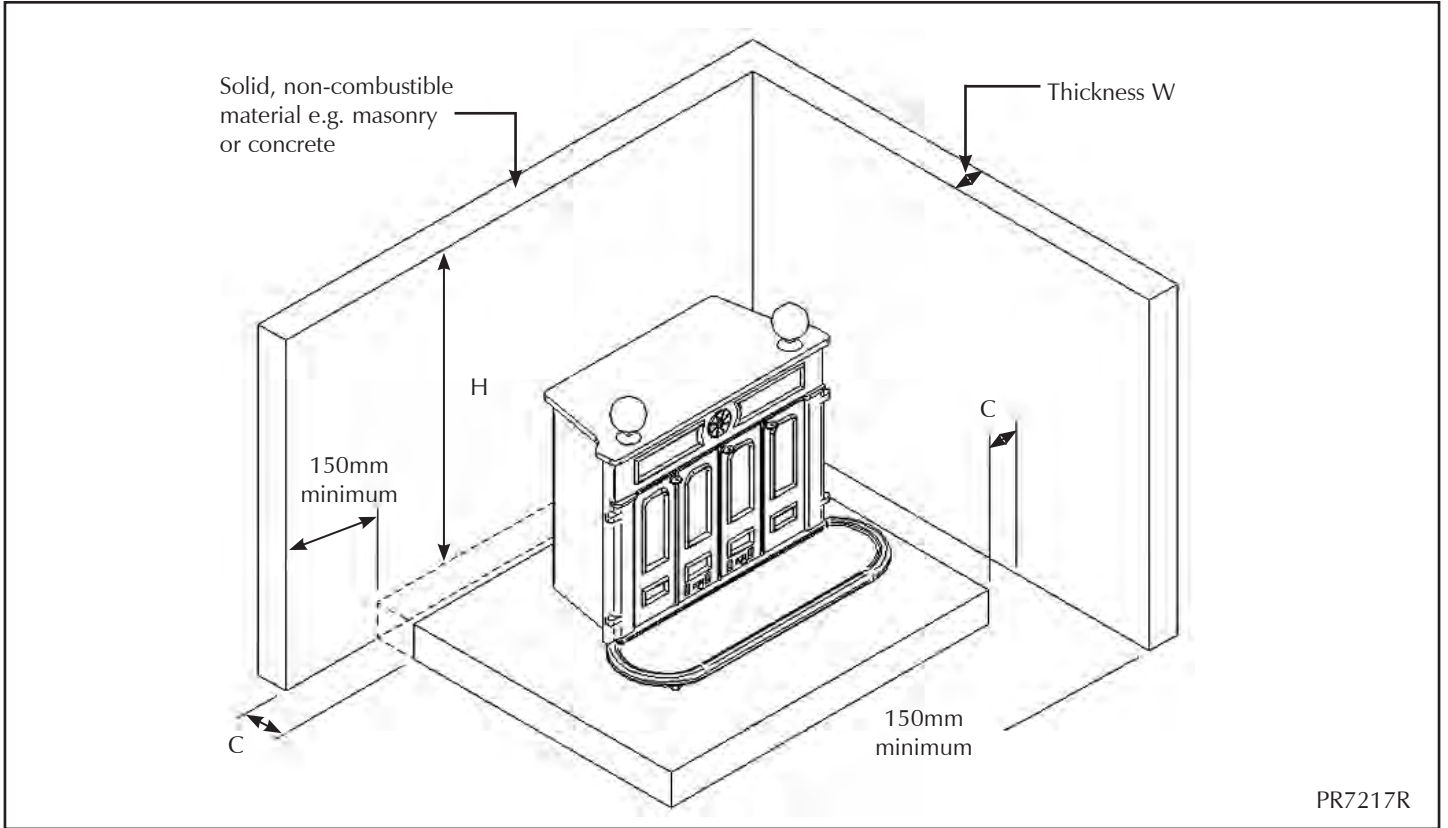

Position of Appliance & Hearth in relation to walls		Requirement for the walls	
Distance of hearth from wall 'C'	Distance of Appliance to wall	Min thickness of Wall 'W'	Min height of wall 'H'
0mm	0mm - 50mm	200mm	Height of appliance + 300mm Or 1200mm from the hearth (take largest dimension)
0mm	51mm - 300mm	75mm	
0 - 150mm	150mm +	75mm	1200mm
150mm +	300mm +	No Minimum Requirement	

Suitable clearance should be allowed around the stove to enable the correct fitting and maintenance of the appliance.

Any clearances should be confirmed by making a site survey and a physical check of wall thickness and dimensions.

PRE-INSTALLATION CHECKS

1. VENTILATION

<u>Model</u> Small Regency - 1000 Medium Regency - 1001 Large Regency - 1002			Small Regency	Medium Regency	Large Regency
Flue/Chimney Size	Without liner system round (diameter)	mm	200	200	200
		inch	8	8	8
	Without liner system (square) minimum dimension	mm	180	180	180
		inch	7	7	7
	With liner or factory made system (diameter) <small>installed in accordance with manufacturers instructions</small>	mm	200	200	200
		inch	8	8	8
Flue/Chimney minimum height*		m	4.5	4.5	4.5
		feet	15	15	15

* When measured from the top of the appliance to the top of the flue, with no horizontal sections and a maximum of 4 bends with angles of less than 45°

- 1.1 This appliance requires ventilation to supply combustion air. Any room containing the appliance must have a permanent air vent opening with a total free area of at least 50% of the appliance throat area.
- 1.2 Increase air supply provisions where a room contains multiple appliances.
- 1.3 If vents open into adjoining rooms or spaces there must be an air vent of at least the same size direct to the outside.
- 1.4 Permanent air vents should be non-adjustable and positioned where they are unlikely to become blocked.
- 1.5 Site the vents where cold draught is unlikely to cause discomfort. This can be avoided by placing vents near ceilings or close to the appliance, see Diagram opposite.

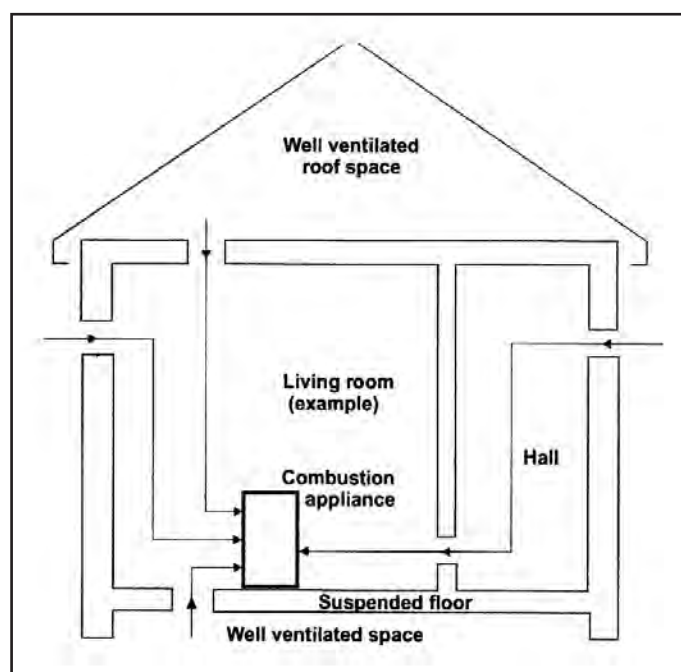

PRE-INSTALLATION CHECKS

2. ADDITIONAL VENTILATION

2.1 Additional ventilation will be required to comply with the requirements of the Building Regulations. This should be provided using a permanently open air vent, of the size listed, which is positioned so that it is not liable to be blocked both inside and outside the building.

2.2 Extractor fans or cooker hoods must not be placed in the same room or space as this can cause the appliance to emit fumes into the room.

2.3 **If any of these checks reveal problems do not proceed with the fitting of the appliance until they have been rectified.**

<u>Model</u> Small Regency - 1000 Medium Regency - 1001 Large Regency - 1002		Small Regency	Medium Regency	Large Regency
Additional Ventilation	mm ²	28500	35400	40800
	cm ²	285	354	408
	in ²	44	55	63

INSTALLATION INSTRUCTIONS

LEGAL REQUIREMENTS

Before installation of this product please read these instructions fully.

It is very important to understand the requirements of the national Building Regulations* and standards**, along with any local regulations and working practices that may apply. Should any conflict occur between these instructions and these regulations then the regulations must apply.

Your local Building Control Office can advise regarding the requirements of the regulations.

The appliance must be fitted by a registered installer, or approved by your local building control officer.

Works must be carried out with care to meet the requirements of Health and Safety† and comply with the Health and Safety rules, and any new regulations introduced during the lifetime of these instructions.. Particular attention should be drawn to:

- **Handling:** The appliance is heavy. Adequate facilities must be available for loading, unloading and site handling.
- **Fire Cement:** Some fire cement is caustic and must not come into contact with the skin. Protective gloves must be worn. Wash hands thoroughly with plenty of water after contact with skin.
- **Asbestos:** This appliance contains no asbestos. If there is the possibility of disturbing any asbestos in the course of installation seek specialist guidance and use appropriate equipment.
- **Metal Parts:** Take care when installing or servicing the stove to avoid personal injury.

A faulty installation can cause danger to the inhabitants and structure of the building.

For users of this appliance:

Your building insurance company may require you to inform them that you have installed a new heating appliance. Check that your cover is still valid after installing the appliance.

1. INSTALLING THE APPLIANCE

Each installation is unique to the property so it is not possible to give details to suit every setting. The installation must comply with Building Regulations and be made using "best practice" construction methods.

Many fireplace openings have a supporting lintel. Do not remove without supporting the remaining structure of the building. **Do not support the structure with the appliance or the flue system.**

1.1 Take care when installing the appliance. Careless handling and use of tools can damage the finish and/or area.

1.2 Assemble the appliance as detailed:

- Open the box and remove the ash lip plate which is packed separately at the back of the appliance, secured by wire

- Open the doors and remove the carton containing the following items: Flue pipe adaptor
3 Legs
Blanking plate
Screws
- Remove the grate and ash pan
- Lay the appliance carefully on it's back
- Fit ash lip to front of appliance between bottom of appliance sides and appliance bottom plate
- Line up the row of four holes in the lip plate with the corresponding holes in the bottom plate
- Secure with 4 flat headed screws
- Secure appliance bottom plate to appliance sides with 2 long screws through the remaining 2 holes

- Choose top or rear flue exit:

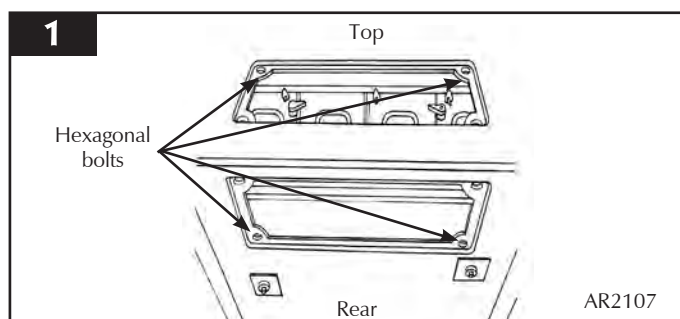

- Fit flue collar and blanking plate to suit
- Attach flue collar to top or rear with hexagonal bolts, see picture 2
- Seal with fire cement if desired
- Secure blanking plate with clamping bar

1.3 Top flue pipe installation

- Seal with fire cement if desired
- Lift appliance into position
Take care not to damage the hearth finish.
- Connect appliance to the chimney using flue pipe
- Secure with self tapping screw
- Seal the connecting joints

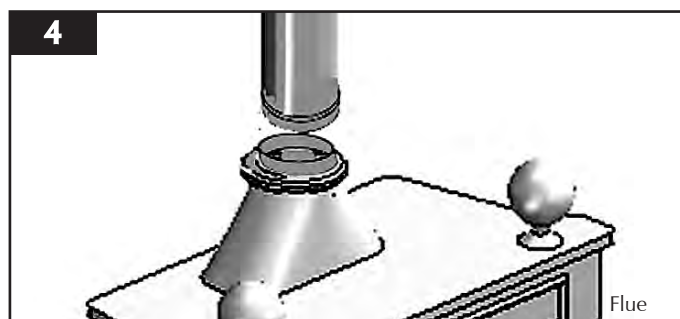

The Flue must be installed in accordance with manufacturers instructions.

INSTALLATION INSTRUCTIONS

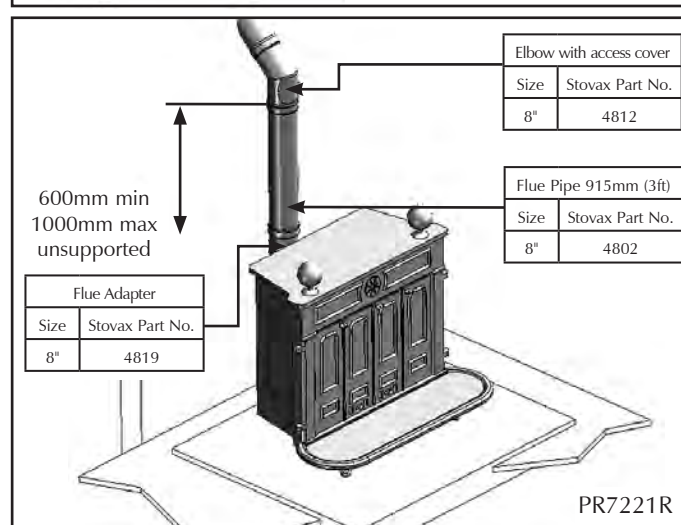
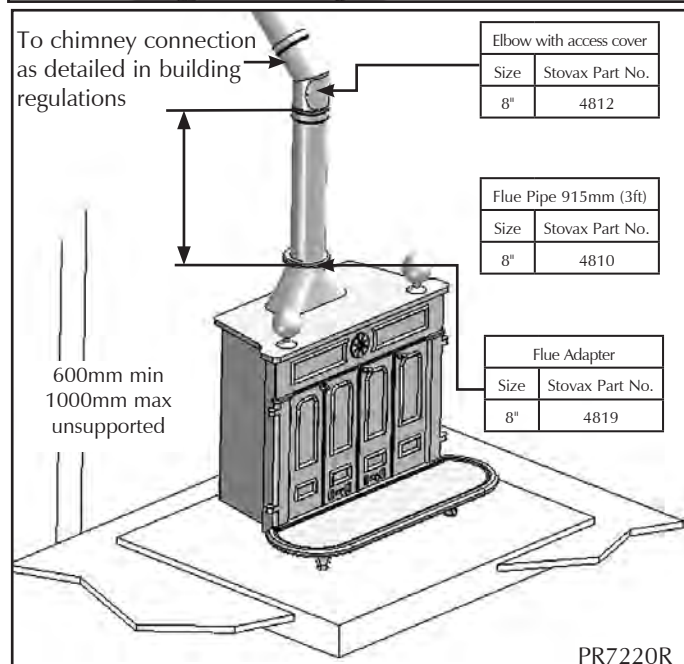
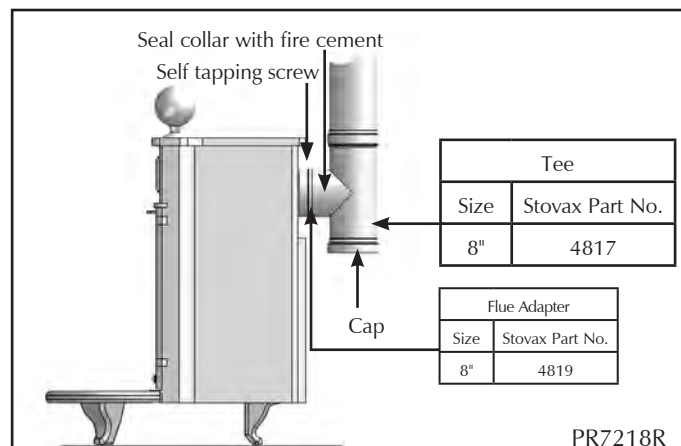
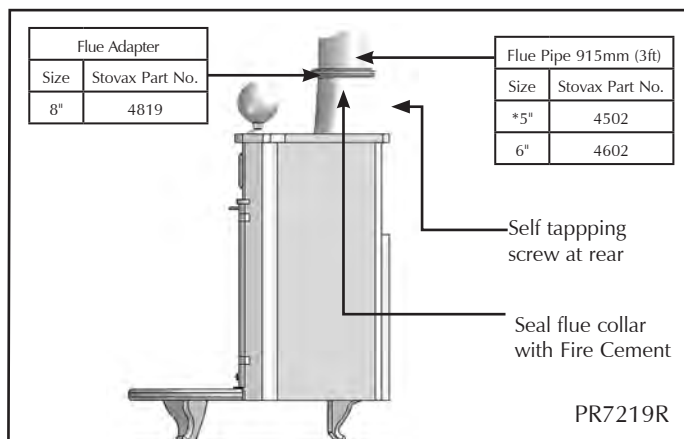

1.3 Rear flue pipe installation

- Insert a tee into the flue collar
The tee piece is used as cleaning access.
- Lift appliance into position
Take care not to damage the hearth finish.
- Level using adjustable bolts, see picture 1
- Connect tee to the chimney using flue pipe
- Secure with self tapping screw
- Seal the connecting joints

Do not use a 90° elbow to make this connection

The Flue must be installed in accordance with manufacturers instructions.

2. FITTING AND REMOVAL OF BAFFLE

- 2.1 To maintain safe and efficient combustion the appliance is fitted with a baffle in the top of the firebox.
- 2.2 Allow the appliance to cool fully before removing baffle system.
- 2.3 To remove the baffle, lift the baffle plate, rotate it and then slide it out through the front.
- 2.4 It is important to remove and clean the baffle system to ensure the flue ways are clear of soot and debris and to ensure the safe and efficient operation of the appliance. The frequency of cleaning will depend on the appliance operating conditions.
- 2.5 Replace any damaged baffles immediately.
- 2.6 Do not modify the baffle system.
- 2.7 To remove the baffle, lift the baffle plate, rotate it and then slide it out through the front.
- 2.8 Replacement is the reverse of the above.

INSTALLATION INSTRUCTIONS

3. FITTING AND REMOVAL OF THE GRATE

- 3.1 The grate must be fitted for the burning of all fuels.
- 3.2 To fit the grate place on the runners on the side of the firebox.
- 3.3 Place ashpan under the grate.
- 3.4 Removal is the reverse of the above procedure

4. OPTIONAL ADDITIONS

The appliance comes with the additional option of a cast iron Bean Pot

- 4.1 Seasoning Cast Iron Cookware
Seasoning cast iron pans makes them nonstick and increases longevity. When new they are grey in colour, but after usage turn darker. This is normal and to be expected

- 4.2 New Pans

To season from new:

- Preheat oven to 250° - 300°
- Coat with lard or bacon grease

Do not use vegetable oil as it leaves surfaces sticky and does not season properly.

- Put pan in the oven for 15 minutes
- Remove and drain off excess grease
- Place back in the oven and bake for a further 2 hours

Repeating this process several times creates a stronger seasoning bond. Use initially for foods high in fat content ie Bacon as grease from these foods will strengthen the seasoning bond.

- 4.3 Re-seasoning Cookware
Seasoning can wear off. You must clean and re-season if food sticks to the surface or there is rust.

To do this you must:

- Heat to a touch safe temperature top to make it easier to clean
- Clean thoroughly with hot water and a scouring pad
- Dry immediately
- Season as outlined above

- 4.4 Care of Cookware
Avoid scratching the surface once seasoned.

You must also:

- Clean pans whilst still warm by rinsing with hot water
Scrape food off where necessary.
- Do not use a scouring pad or detergent
This will break down the seasoning.
- Do not use to store food
Acids in food will break down the seasoning and the food will taste metallic.
- Store with the lids off
Covered pans will retain moisture and rust.
- Re-season if rust appears

COMMISSIONING

COMMISSIONING

1.1 To commission:

- Replace the firebricks, baffle, and log retainer
- Check the door alignment and catch operation
- Check the soundness of door seals, castings and joints
- Check the operation of the air controls

1.2 Now carry out a final smoke draw test:

- First warm the flue with a blowlamp, or similar, for about 10 minutes
- Place a smoke pellet on the centre of the grate, with the air controls open
- Close the door
Smoke should now be drawn up the flue and be seen to exit from the flue terminal
- Complete test with all doors and windows closed in the room where the appliance is fitted
- If there are any extractor fans in adjacent rooms, the test must be repeated with the fans running on maximum and interconnecting doors open
- Check the effect of ceiling fans during the test

If the test fails, re-check the suitability of the flue system and ventilation. An inadequate air supply to the room is potentially dangerous.

- Light the appliance and slowly increase the temperature to operating levels
- Ensure no combustion products enter the room
- Open the main fire door when the appliance reaches operating condition and carry out a spillage test with a smoke match or pellet around the door opening

1.3 If excessive spillage occurs:

- Allow the appliance to cool and re-check the flue system and ventilation

1.4 Finally:

- **Explain the safe operation of the appliance and the use of the controls to the user and the importance of only using suitable fuels**
- **Explain the cleaning and routine maintenance requirements**
- **Explain the requirement to use a suitable fireguard**

when children, elderly or infirm persons are near the appliance

- **Record dealer/supplier details and installer details in *Instructions***

- **Record serial number in page 3 of *Instructions***

This number is required when ordering spare parts and making warranty claims

- **Give the copy of the *Instructions* to the customer**

MAINTENANCE and SERVICING

For a complete list of spare parts and accessories contact your Stovax dealer for the Stovax Fireplace, Stove & Hearth Accessories brochure or call 01392 474011

1. ANNUAL SERVICE

- 1.1 Before the start of the heating season strip, inspect and clean the appliance as detailed:
- Allow appliance to cool
 - Remove all of the following internal parts; baffle, complete grate, and ashpan.
See sections 5 and 6 on how to remove the baffles.
 - Sweep the appliance at this point if it is required
 - Vacuum clean any remaining ash and debris from the inside of the appliance.
Stovax offer a filter/collection attachment for your vacuum cleaner to protect it from fire ash. Ash Clean (Stovax Part No. 2091).
 - Clean the internal surfaces of the appliance using a wire brush and scraper as required
Vacuum and brush the resulting debris from the appliance.
 - Clean the grate parts with a wire brush, and check the parts for any damage
 - Replace any damaged parts
 - Re-fit cleaned internal parts
 - Lightly oil the door catch mechanism and hinge pins
Avoid getting oil onto the door seals and glass.
- To refresh painted finishes use Stovax Thermolac paint.
- 1.2 Use genuine Stovax replacement parts to keep your appliance in safe and efficient working order. Your local Stovax dealer can provide you with the parts you require.

This is a list of the maintenance products you may need to use:

Task	Product name	Stovax Code Number
Preventing build-up of creosote in flue	Protector (15 sachets)	7002
	Protector (1kg tub)	7025
Sealing flue pipe joints	Fire Cement (500g tub)	2020
	Fire Cement (600g cartridge)	2021
Re-painting	Thermolac Black (400ml aerosol)	2019
	Thermolac Black (200ml brush-on)	2057
Cleaning matt black appliances	Colloidal black (85ml)	7000
Protecting your hands	Heat resistant leather gloves	4008

These products, all available from your local Stovax dealer, along with regular maintenance and use of the correct fuels, will help you to keep your appliance in the best possible condition.

- 1.3 If you require more information about Stovax group products visit our web site www.stovax.com
- 1.4 Using the appliance for the first time:
 - Burn at a low output for the first day of use
This allows the seals, fixing glues and paint to fully cure.
- 1.5 During this time the appliance may give off some unpleasant odours:
 - Keep the room well ventilated to avoid a build-up of fumes.
- 1.6 Your Stovax dealer can carry out service and maintenance.

5. FITTING AND REMOVAL OF BAFFLE AND GRATE

- 5.1 See Sections 2 and 3, page 16 for the instructions on how to remove the baffles and grate.

BASIC SPARE PARTS LIST

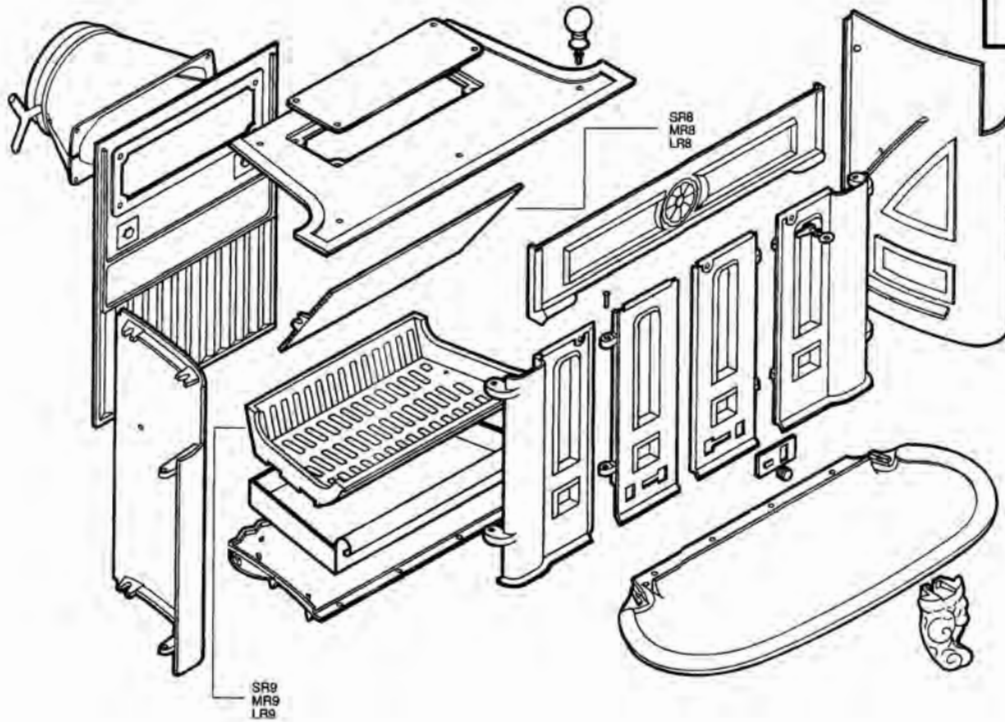
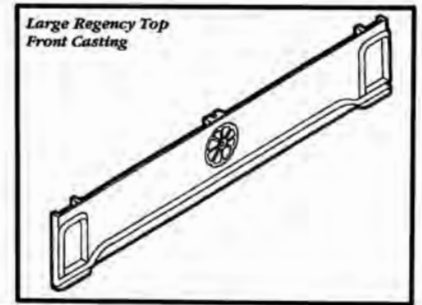

REGENCY - SMALL

Part No.	Description	Casting No.
SR8	Baffle Plate	15123-5
SR9	Grate	10201-5

REGENCY - MEDIUM

Part No.	Description	Casting No.
MR8	Baffle Plate	15123-6
MR9	Grate	10201-6

REGENCY - LARGE

Part No.	Description	Casting No.
LR8	Baffle Plate	15123-7
LR9	Grate	10201-7

SERVICE RECORDS

1ST SERVICE

Date of Service:.....

Next Service Due:.....

Signed:.....

Dealer's Stamp/HETAS Registration Number

3RD SERVICE

Date of Service:.....

Next Service Due:.....

...

Signed:.....

Dealer's Stamp/HETAS Registration Number

5TH SERVICE

Date of Service:.....

Next Service Due:.....

Signed:.....

Dealer's Stamp/HETAS Registration Number

7TH SERVICE

Date of Service:.....

Next Service Due:.....

Signed:.....

Dealer's Stamp/HETAS Registration Number

9TH SERVICE

Date of Service:.....

Next Due:.....

Signed:.....

Dealer's Stamp/HETAS Registration Number

2ND SERVICE

Date of Service:.....

Next Service Due:.....

Signed:.....

Dealer's Stamp/HETAS Registration Number

4TH SERVICE

Date of Service:.....

Next Service Due:.....

Signed:.....

Dealer's Stamp/HETAS Registration Number

6TH SERVICE

Date of Service:.....

Next Service Due:.....

Signed:.....

Dealer's Stamp/HETAS Registration Number

8TH SERVICE

Date of Service:.....

Next Due:.....

Signed:.....

Dealer's Stamp/HETAS Registration Number

10TH SERVICE

Date of Service:.....

Next Service Due:.....

Signed:.....

Dealer's Stamp/HETAS Registration Number

EC Declaration of Conformity



The undersigned, representing the following :

Manufacturer
Stovax Ltd Falcon Road, Sowton Industrial Estate Exeter EX2 7LF

Herewith declare that the products :

Description	Product code
Small Regency	1000
Medium Regency	1001

Description of product : Regency domestic wood and multifuel heating stove product range

Cast iron stove body fitted with decorative cast iron door sets, various decorative trim and fire-grate options. Supplied in various sizes to give a range of heat output options.

are in conformity with the provisions of the following EC Directive(s) when installed in accordance with the installation instructions in the product documentation :

98/106/EEC Construction Products Directive

and the standards referenced below have been applied :

EN 13229 : 2001 Inset appliances including open fires fired by solid fuel – Requirements and test methods

Product : Roomheater fired by solid fuel as covered under the scope of the standards listed. Intended use : Space heating in residential buildings.		
Characteristic	Performance	Report
Fire safety	Satisfies	
Emission of combustion products	Small Regency (1000) CO @ 13% O ₂ Wood 0.29% - Briquetted fuel 0.62% Medium Regency (1001) CO @ 13% O ₂ Wood 0.17% - Briquetted fuel 0.48%	EZ/07/1991/09-10
Release of dangerous substance	None	
Surface temperature	Satisfies	
Mechanical resistance (to carry a chimney/flue)	Maximum weight to be supported 25Kg	
Thermal output / Efficiency	Small Regency (1000) Wood 5.0Kw @ 30% - Briquetted fuel 4.0Kw @ 38% Medium Regency (1001) Wood 8.0Kw @ 39% - Briquetted fuel 4.0Kw @ 39%	EZ/07/1991/09-10

Test laboratory : 1641

Name : D. J. Saunders

Position : Design Engineer

Signature :

Date : 12 / 11 / 2007

Sheet 1 of 1

STOVAX

Stovax Ltd, Falcon Road, Sowton Industrial Estate, Exeter, Devon, England EX2 7LF

Tel: (01392) 474011 Fax: (01392) 219932 E-mail: info@stovax.com www.stovax.com