

owner's manual

Audio/Video Receiver

Professional Series



REGA

INTRODUCTION

The RCA STAV-3860 has these great features.

Five Channels of Independent Amplification — five independent power amplifiers, each rated at 60W, ensure accurate, dynamic reproduction of all multi-channel material.

Dolby* Pro Logic — enjoy stunning multi-channel, surround sound effects from movies and other material recorded in Dolby Surround/Pro Logic. Enhance your listening experience further with built-in signal processing that recreates the movie theater ambience in your living room.

Digital Surround Effects — using Digital Signal Processing (DSP) technology, various listening environments, such as a theater or a jazz club, may be simulated and applied to any music or video source.

DVD 5.1 Channel Input — a special 5.1 Channel input makes the STAV-3860 fully compatible with Dolby Digital decoders and DVD players with 5.1 channel outputs.

The Energy-saving Design — this unit is designed to use minimal electricity when power is switched OFF (in Standby mode). Regarding the value of the power consumption in standby mode, refer to "Specifications" on pages 31.

Note to the Cable TV System Installer:

This reminder is provided to call the CATV system installer's attention to Article 820-40 of the National Electrical Code that provides guidelines for proper grounding and, in particular, specifies that the cable ground shall be connected to the grounding system of the building as close to the point of cable entry as practical.

* Manufactured under license from Dolby Laboratories.
"Dolby", "Pro Logic" and the double-D symbol are trademarks of Dolby Laboratories.
Confidential unpublished works. © 1992-1997 Dolby Laboratories. All rights reserved.

©1999 Tandy Corporation.
All Rights Reserved.

IMPORTANT SAFETY INSTRUCTIONS

This receiver is made and tested to meet exacting safety standards. It meets both UL and FCC requirements and complies with safety performance standards of the US Department of Health and Human Services.

WARNING: TO REDUCE THE RISK OF FIRE OR ELECTRIC SHOCK, DO NOT EXPOSE THIS APPLIANCE TO RAIN OR MOISTURE.

	CAUTION RISK OF ELECTRIC SHOCK. DO NOT OPEN.	
---	---	---

CAUTION: TO REDUCE THE RISK OF ELECTRIC SHOCK, DO NOT REMOVE THE COVER. NO USER-SERVICEABLE PARTS INSIDE. REFER SERVICING TO QUALIFIED SERVICE PERSONNEL.



This symbol is intended to alert you to the presence of dangerous voltage inside the product that can cause shock. Do not open the product's case.



This symbol is intended to alert you to important operating and maintenance instructions in this owner's manual.

Careful attention is devoted to quality standards in the manufacture of your cassette deck, and safety is a major factor in its design. However, safety is also your responsibility.

This section lists important information that will help you properly use and enjoy your cassette deck and accessories. Read all the included safety and operating instructions before using your cassette deck, follow them closely, and retain them for future reference.

Heed Warnings — Follow all warnings on the product and in the operating instructions.

Cleaning — Unplug this product from the wall outlet before cleaning. Use only a damp cloth for cleaning. Do not use liquid or aerosol cleaners.

Attachments — Do not use attachments/accessories not recommended by the product manufacturer, as they might create a hazard.

Water and Moisture — Do not use this product near water (for example, near a bathtub, washbowl, kitchen sink, or laundry tub; in a wet basement; or near a swimming pool).

Accessories — Do not place this product on an unstable cart, stand, tripod, bracket, or table. The product may fall, causing serious injury to a child or adult, and serious damage to the product. Use only with a cart, stand, tripod, bracket, or table recommended by the manufacturer or sold with the product. Follow the manufacturer's instructions for mounting, and use a recommended mounting accessory.



Carts — Move the product on a cart carefully. Quick stops, excessive force, and uneven surfaces may cause the product/cart to overturn.

Ventilation — Slots and openings in the cabinet provide ventilation, ensure reliable operation, and protect from overheating. Do not block or cover these openings, and do not place the product on a bed, sofa, rug, or other similar surface. Do not place the product in a built-in bookcase or rack unless it provides proper ventilation as specified by the manufacturer.

Power Sources — Operate this product using only the power source indicated on its marking label. If you are not sure of your home's power type, consult your product dealer or local power company.

Polarization — This product is equipped with a polarized AC line plug (a plug having one blade wider than the other). This plug will fit in the power outlet only one way. This is a safety feature. If you cannot insert the plug fully into the outlet, try reversing the plug. If the plug still doesn't fit, contact your electrician to replace your obsolete outlet. Do not defeat the safety purpose of the polarized plug. If you need an extension, use a polarized cord.

Power-Cord Protection — Route power-supply cords so they are not likely to be walked on or pinched by items placed on or against them, paying particular attention to cords at plugs, convenience receptacles, and the point where they exit from the product.

Lightning — For added protection for this product during a lightning storm, or when it is left unattended and unused for long periods of time, unplug it from the wall outlet and disconnect the antenna or cable system. This will prevent damage to the product due to lightning and power-line surges.

Overloading — Do not overload wall outlets, extension cords, or integral convenience receptacles, as this can result in a risk of fire or electric shock.

Objects and Liquids — Never push objects of any kind into this product through openings, as they may touch dangerous voltage points or short out parts that could result in a fire or electric shock. Never spill liquid of any kind on the product.

Servicing — Do not attempt to service this product yourself, as opening or removing covers may expose you to dangerous voltage or other hazards. Refer all servicing to qualified service personnel.

Damage Requiring Service — Unplug this product from the wall outlet and refer servicing to qualified service personnel under the following conditions:

- When the power-supply cord or plug is damaged.
- If liquid has been spilled or objects have fallen into the product.
- If the product has been exposed to rain or water.
- If the product does not operate normally by following the operating instructions. Adjust only those controls that are covered by the operating instructions, as an improper adjustment of other controls may result in damage and will often require extensive work by a qualified technician to restore the product to normal operation.
- If the product has been dropped or damaged in any way.
- When the product exhibits a distinct change in performance.

Replacement Parts — When replacement parts are required, be sure the service technician uses replacement parts specified by the manufacturer or having the same characteristics as the original part. Unauthorized substitutions may result in fire, electric shock, or other hazards.

Safety Check — Upon completion of service or repairs to this product, ask the service technician to perform safety checks to determine that the product is in proper operating condition.

Wall or Ceiling Mount — The product should be mounted to a wall or ceiling only as recommended by the manufacturer.

Heat — The product should be situated away from heat sources such as radiators, heat registers, stoves, or other products (including amplifiers) that produce heat.

Warning: This receiver uses a laser. Because of possible eye injury, only a qualified service person should remove the cover or attempt to service this device.

Cautions

- The use of controls or adjustments, or the performance of procedures other than specified herein, can result in hazardous exposure to laser light.
- To prevent electric shock do not use this polarized plug with an extension cord, receptacle, or other outlet unless the blades can be fully inserted to prevent blade exposure.

TABLE OF CONTENTS

Preparation	6
Checking the Supplied Accessories	6
Using this Manual	6
Installing the Receiver	6
Preparing the Remote Control	7
Connecting Your System	8
Connecting Antennas	8
Connecting Audio Components	9
Connecting DVD 5.1 Channel Components	10
Connecting Video Components	10
Connecting Speakers	11
AC Outlet	12
Setting Up for Surround Sound	13
Setting Up for Surround Sound	13
Displays and Controls	17
Front Panel	17
Display	18
Remote Control	19
Listening in Surround Sound	20
Listening in Dolby Pro Logic Mode	20
Listening in DVD 5.1 Channel Input Mode	21
Listening in DSP Mode	22
Using the Tuner	23
Finding a Station	23
Tuning Directly to a Station	24
Memorizing Stations	24
Recalling Memorized Stations	25
Making a Recording	26
Making an Audio or Video Recording	26
Additional System Control	27
CD Player Controls	27
Cassette Deck Controls	28
Additional Information	29
Troubleshooting	29
Specifications	31

PREPARATION

CHECKING THE SUPPLIED ACCESSORIES

Please check that you've received the following supplied accessories:

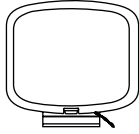

AM Loop Antenna



FM Wire Antenna



Remote Control Unit

USING THIS MANUAL

This manual is for the STAV-3860 audio/video receiver. It is divided into two main sections:

Set up

This section covers installing your receiver and connecting all the other components in your home theater system to it. It also describes how to set up a multi-channel speaker system to take full advantage of the great surround sound features of your receiver.

Operation

This section shows you how to use every feature of the receiver and its remote control unit. It also covers using the supplied remote control to operate your other home theater components. To find out more about a specific button, control or indicator, see Displays and Controls starting on page 17. This will point you to the relevant chapter in the manual.

In the Additional Information section (p.29–31) you'll find a troubleshooting section and specifications.

The following symbols are used throughout this manual:



Provides detailed precautions and advice on operations, etc.



Indicates that display is blinking.

INSTALLING THE RECEIVER

Notes:

- Do not place objects directly on top of this unit. This would prevent proper heat dispersal.
- When installing in a rack, shelf, etc., be sure to leave more than 8 inches of space above the receiver.

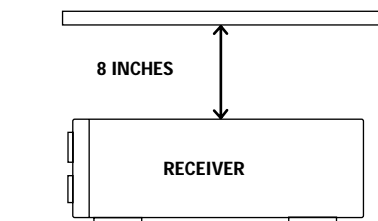

PREPARING THE REMOTE CONTROL

Loading the batteries

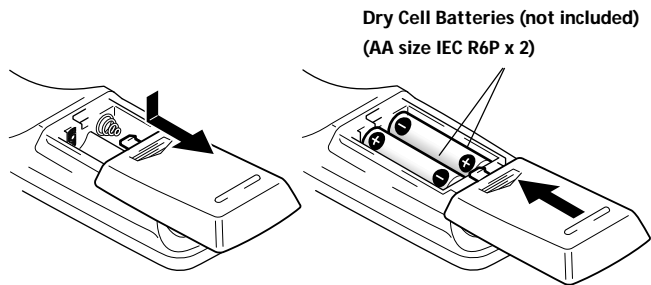

CAUTION:

Incorrect use of batteries may result in such hazards as leakage and bursting. Observe the following precautions:

- Never use new and old batteries together.
- Insert the plus and minus sides of the batteries properly according to the marks in the battery case.
- Batteries with the same shape may have different voltages. Do not use different batteries together.

Operating Range of Remote Control Unit

The remote control may not work properly if:



- There are obstacles between the remote control and the receiver's remote sensor.
- Direct sunlight or fluorescent light is shining onto the remote sensor.
- The receiver is located near a device that is emitting infrared rays.
- The receiver is operated simultaneously with another infrared remote control unit.

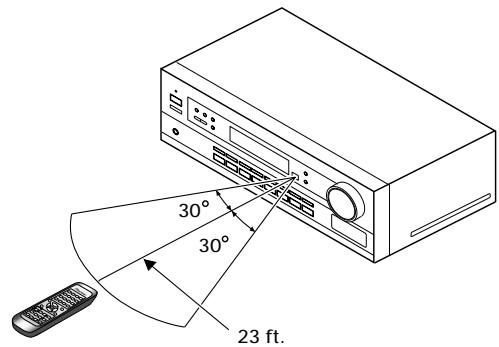

The FUNCTION & SOURCE SELECT Buttons on the Remote Control

Please note that the remote control has two types of buttons, one called **FUNCTION** and a set of buttons called **SOURCE SELECT**. Use the **FUNCTION** button to choose the component you want to listen to (CD, CDR/TAPE, TUNER, etc.) and use the **SOURCE SELECT** buttons to change which component the remote control itself will operate. Thus, if the STAV-3860 is in TUNER mode, for example, and you want to listen to your CD player, you need to select the CD mode with the **FUNCTION** button.

Operating other RCA Components

By connecting a control cord (optional), you can control other RCA professional series equipment using this remote control unit. Point the remote control unit towards the remote sensor of this unit, even when operating other equipment.

The remote control signals are received by the remote sensor of this unit, and sent to the other devices via the **CONTROL OUT** terminal.



You can also control RCA professional series components by pointing the receiver's remote control directly at the component. This type of operation does not require control cords.

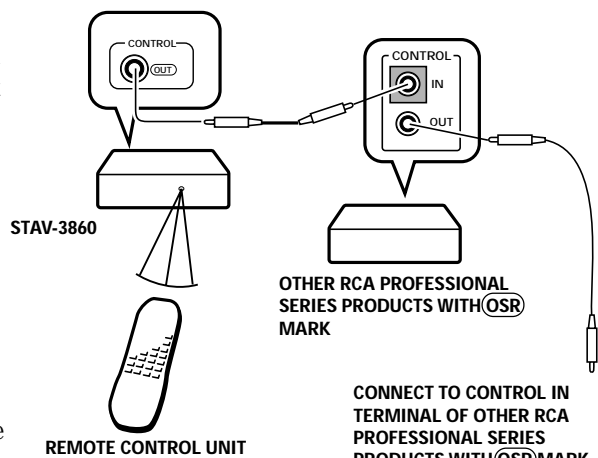

CONNECTING YOUR SYSTEM

CONNECTING ANTENNAS

Connect the AM loop antenna and the FM wire antenna as shown below. To improve reception and sound quality, connect external antennas (see Using external antennas, below). Always make sure that the receiver is switched off and unplugged from the wall outlet before making or changing any connections.

AM Loop Antenna

Assemble the antenna and connect to the receiver. Attach to a wall, etc. (if desired) and face in the direction that gives the best reception.

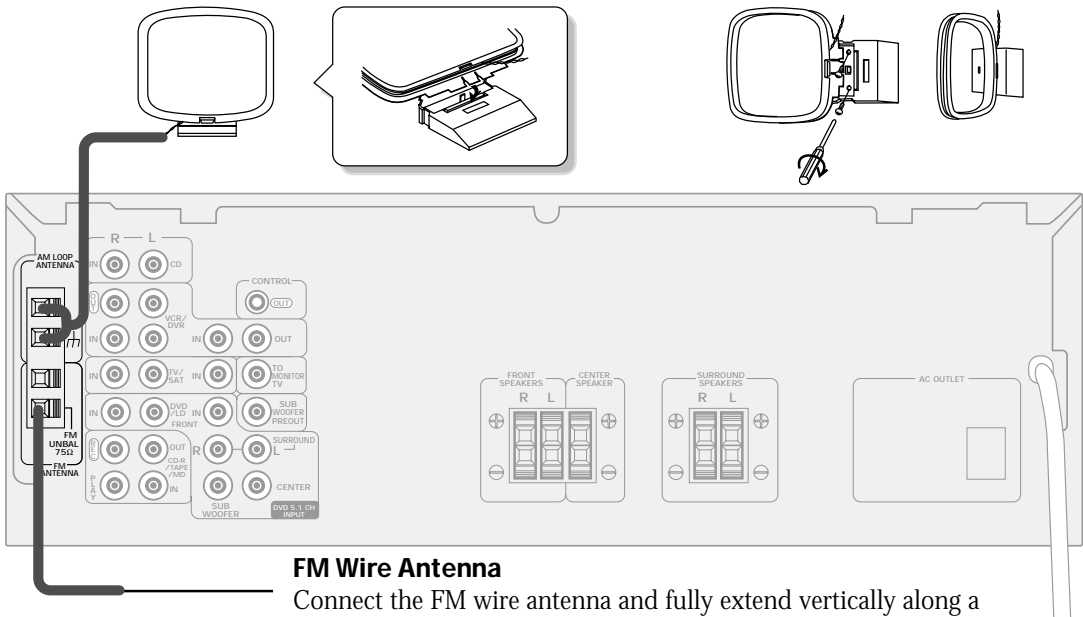

FM Wire Antenna

Connect the FM wire antenna and fully extend vertically along a window frame or other suitable area.

Antenna Snap Connectors

Twist the exposed wire strands together and insert into the hole, then snap the connector shut.

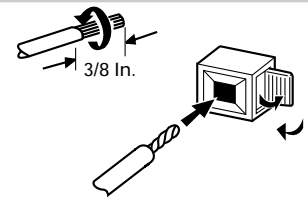

Using External Antennas

■ To Improve FM Reception

Connect an external FM antenna.

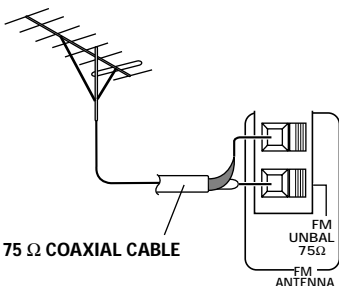

■ To Improve AM Reception

Connect a 15–18 feet length of vinyl-coated wire to the AM antenna terminal without disconnecting the supplied AM loop antenna.

For the best possible reception, suspend horizontally outdoors.

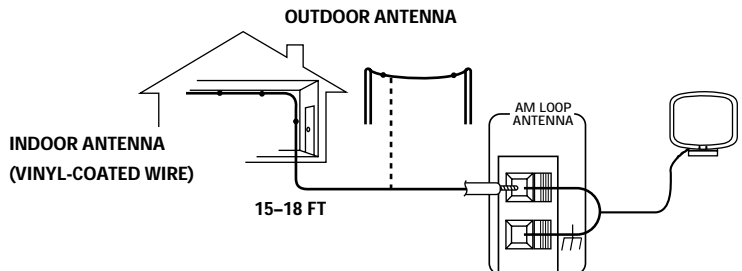

CONNECTING AUDIO COMPONENTS

Connect your audio components as shown below. When connecting equipment, always make sure the power is switched off and the power cord is disconnected from the wall outlet.

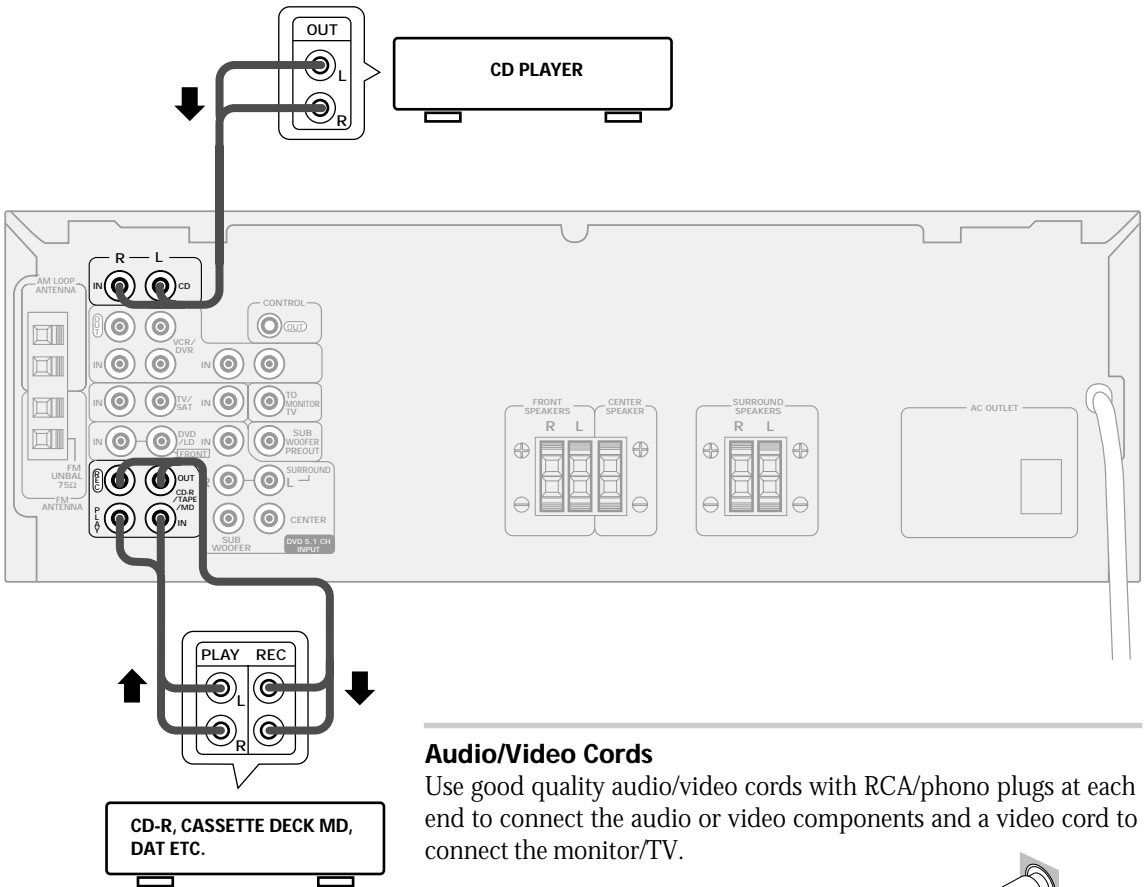

Audio/Video Cords

Use good quality audio/video cords with RCA/phono plugs at each end to connect the audio or video components and a video cord to connect the monitor/TV.

Connect red plugs to R (right), white plugs to L (left), and the yellow plugs to VIDEO.

Be sure to push the plugs securely into their sockets.

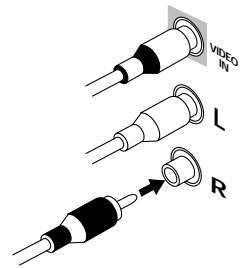

Cassette Deck Placement

Depending on where the cassette deck is placed, noise caused by leakage flux from the transformer in the receiver may occur during playback. If you experience noise, move the cassette deck farther away from the receiver.

CONNECTING DVD 5.1 CHANNEL COMPONENTS

DVD and LD discs are compatible with both 2 channel and 5.1 channel audio output formats. Refer to page 21 for more information on how to switch between the two input methods. You can connect a DVD player or multi channel decoder equipped with 5.1 analog outputs to the 5.1 analog inputs on the receiver. Always make sure that the receiver is switched off and unplugged from the wall outlet before making or changing any connections.

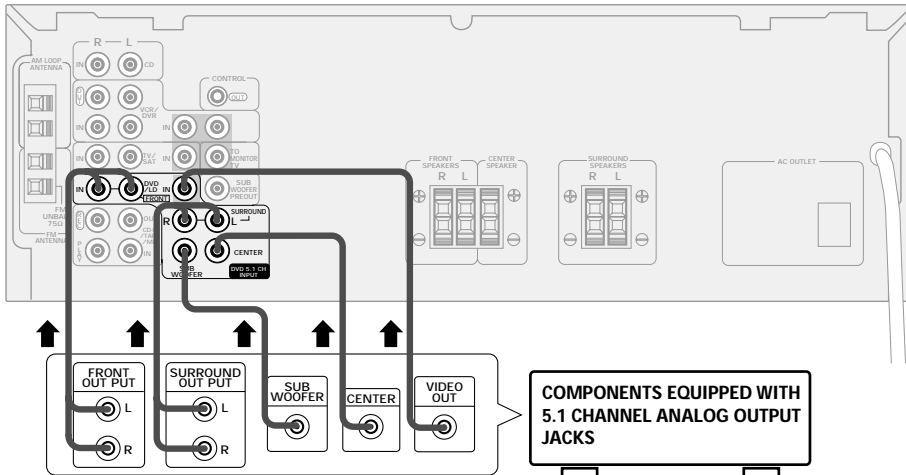

memo The 5.1 channel input can only be used when DVD 5.1 CH is selected.

CONNECTING VIDEO COMPONENTS

Connect your video components as shown below. When connecting equipment, make sure the power is switched off and the power cord disconnected from the wall outlet.

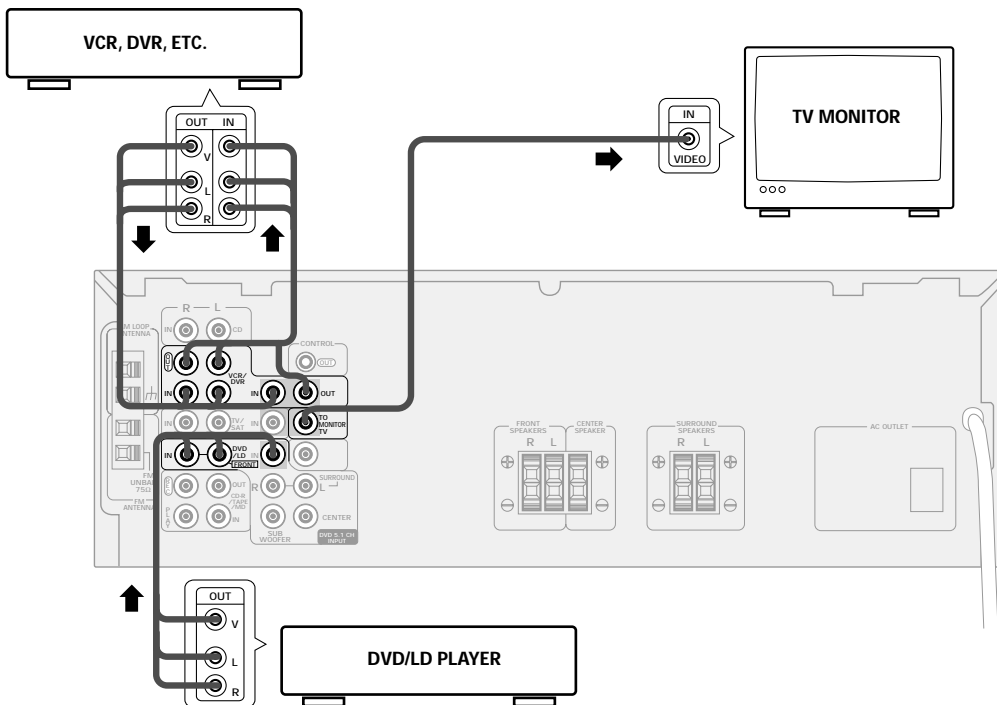

CONNECTING SPEAKERS

Connect your speakers as shown below. Be sure to connect each speaker to the appropriate speaker terminals, and also to connect the positive and negative terminals correctly (positive to positive, negative to negative). When connecting equipment, always make sure the power switched off and the power cord is disconnected from the wall outlet.

- Use speakers with a nominal impedance of 8 Ω to 16 Ω .

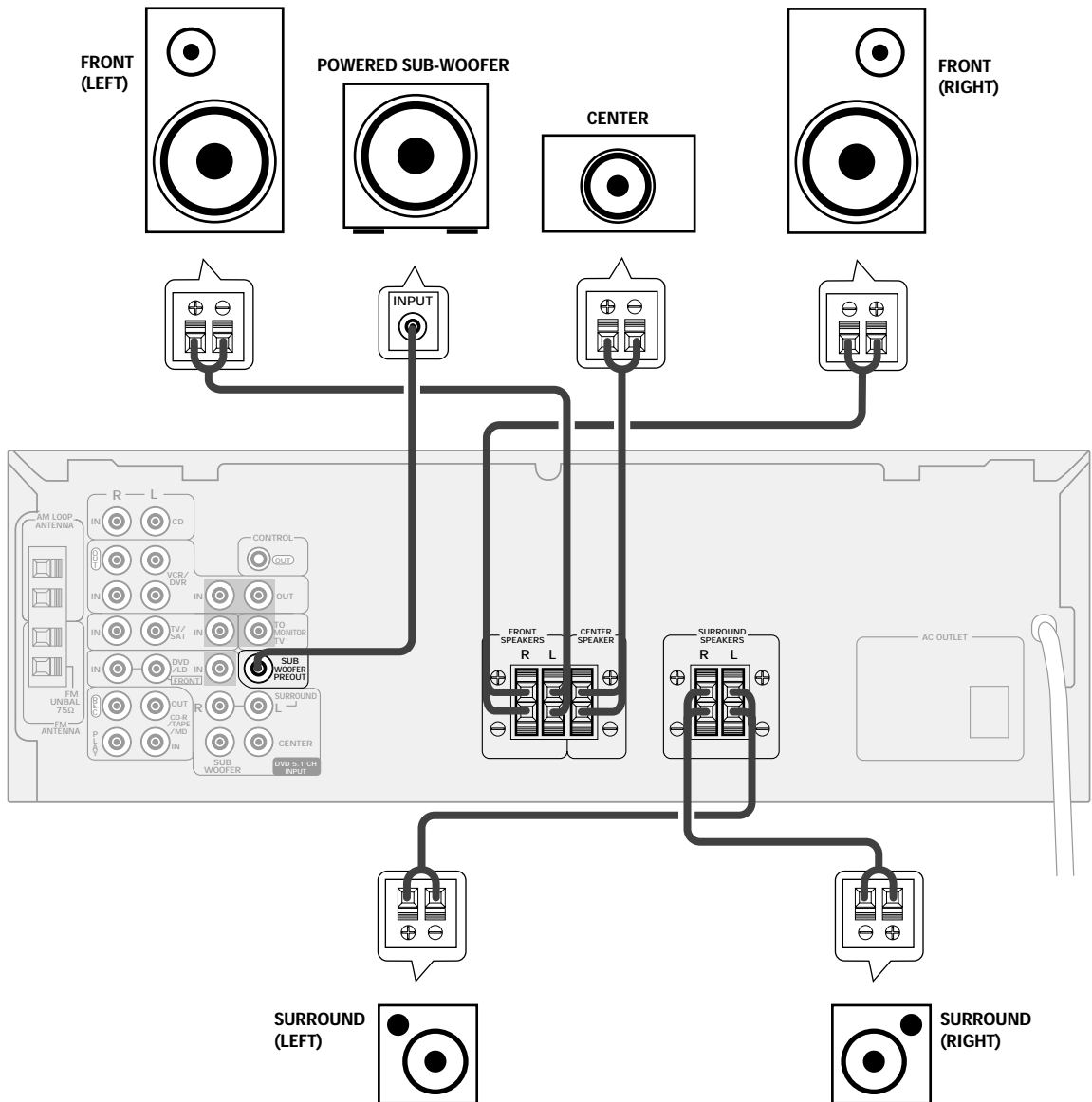

Speaker terminals

Use good quality speaker wire to connect the speakers to the receiver.

- ① Twist about 1/2 inch of bare wire strands together.
- ② Unclip the speaker terminal and insert the wire.
- ③ Snap shut the speaker terminal to secure.

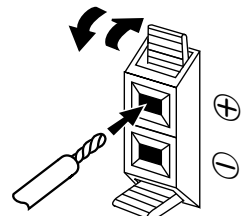

Hints on Speaker Placement

Speakers are usually designed with a particular placement in mind. Some are designed to be floorstanding, while others should be placed on stands to sound their best. Some should be placed near a wall; others should be placed away from walls. Follow the guidelines on placement that the speaker manufacturer provided with your particular speakers.

- Place the front left and right speakers at equal distances from the TV.
- When placing speakers near the TV, we recommend using magnetically shielded speakers to prevent possible interference, such as discoloration of the picture when the TV is switched on. If you do not have magnetically shielded speakers and notice discoloration of the TV picture, move the speakers farther away from the TV.
- Install the center speaker above or below the TV so that the sound of the center channel is localized at the TV screen.

CAUTION: If you choose to install the center speaker on top of the TV, be sure to secure it with putty, or by other suitable means, to reduce the risk of damage or injury resulting from the speaker falling from the TV in the event of external shocks such as earthquakes.

- If possible, install the surround speakers slightly above ear level.
- Try not to install the surround speakers farther away from the listening position than the front and center speakers. Doing so can weaken the surround sound effect.

To achieve the best possible surround sound, install your speakers as shown below. Be sure all speakers are installed securely to prevent accidents and improve sound quality.

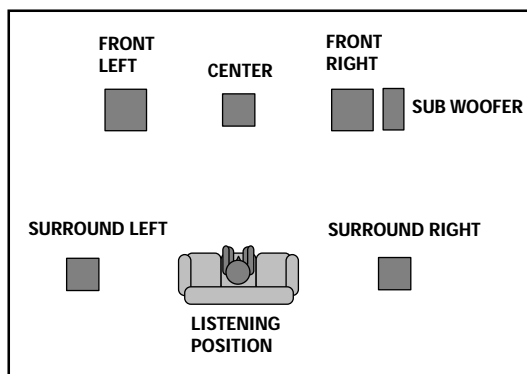

3-D View of Speaker Set Up

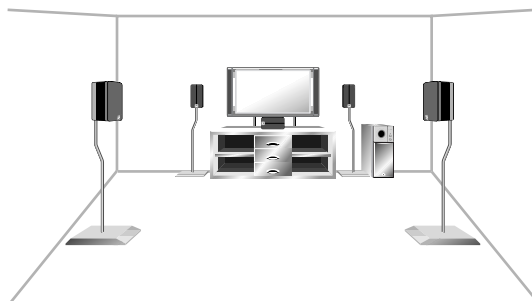

AC OUTLET [SWITCHED 100 W (0.8 A) MAX]

Power supplied through this outlet is turned on and off by the receiver's STANDBY/ON button. Total electrical power consumption of connected equipment should not exceed 100 W (0.8 A).

Do not connect a heater, TV, etc.



- This unit should be disconnected by removing the power plug from the wall socket when not in regular use.
- Do not connect appliances with high power consumption such as heaters, irons, or television sets to this AC OUTLET in order to avoid overheating and fire risk. This can also cause the receiver to malfunction.

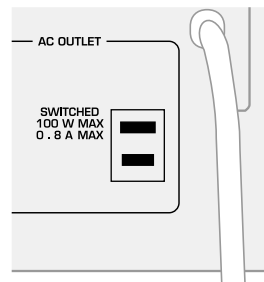

CAUTION: DO NOT CONNECT A MONITOR OR TV SET TO THIS UNIT'S AC OUTLET.

SETTING UP FOR SURROUND SOUND

SETTING UP FOR SURROUND SOUND

The STAV-3860 offers several options for surround sound listening, depending on the speakers in your set up. Having installed the speakers in your room, it's important to set up the relative volume levels and delay time in order to make the most of the receiver's surround sound capabilities. You only need to make these settings once, unless you change the placement of your current speaker system or add new speakers.

Setting the Center Mode, the Subwoofer and Speaker Distances

It is important to set the type of center mode which corresponds to your speaker system, set the subwoofer on/off, set speaker distances, and set volume levels of each speaker. From your normal listening position, the volumes of the various speakers in your system should appear to be equal. Follow the steps below for settings, especially the volumes of the center and surround speakers relative to the main front speakers for Dolby Pro Logic mode, 5.1 CH. mode and the DSP mode.

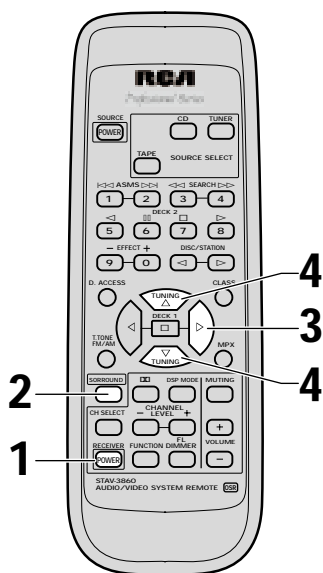

- 1 Switch on the receiver.
- 2 Press the **SURROUND** button.
- 3 Press the **▶** button to select the surround sound setup mode. Repeatedly pressing the button cycles through the three setup modes (center mode setup; subwoofer setup; distance setup). The mode appears in the display on the front panel.
- 4 Use the **▲▼** buttons to select one of the four types of center mode.

The center mode cycle and the diagrams below explain each center mode.

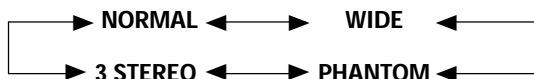

Normal

Middle and high frequency sounds are heard from the center speaker.

Bass frequencies from the center channel are played through the front speakers.

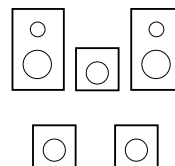

Wide

If a full range speaker is used for the center channel, all center channel sound, including bass frequencies, are heard through the center speaker.

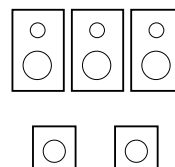

Phantom

Center channel sounds are played through both front speakers equally.

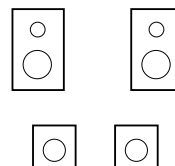

3 Stereo

Surround channel sounds and center channel bass frequencies are heard through the front stereo speakers.

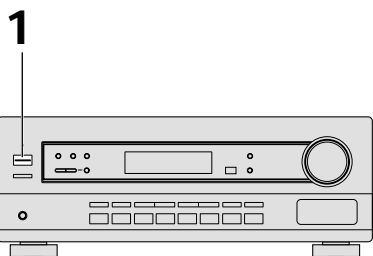
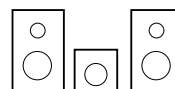

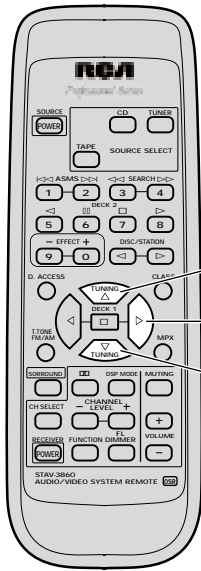

- 5 Press the ► button to select the **SUBWF** (subwoofer) select mode.
- 6 Use the ▲▼ buttons to turn the subwoofer function on or off. Select **SUBWF ON** if you have a subwoofer and **SUBWF OFF** if you don't have a subwoofer.
- 7 Press the ► button to select the distance mode for the **FRNT** (front) speakers.
For true surround sound effect, the sound from the front speakers and the surround speakers should arrive to the listener's ears at a slightly different time. Telling the receiver how far your front and surround speakers are from your listening position will allow for this. The first distance setting you'll see will be **FRNT** for your front speakers. You can set the distance in a range from 1–30 feet.
- 8 Press the ▲▼ buttons to increase/decrease the distance of the **FRNT** speakers.
You should determine how far the speakers are from your normal listening position and set the distance accordingly. You can set the distance in a range from 1–30 feet.
- 9 Press the ► button to select the distance mode for the **SURR** (surround) speakers.
- 10 Press the ▲▼ buttons to increase/decrease the distance of the **SURR** speakers.

Again, determine how far the speakers are from your normal listening position and set the distance accordingly. As above, you can set the distance in a range from 1–30 feet.

When you are finished setting up the delay time, the receiver will return to normal operating mode after about 20 seconds. Alternatively, you can cycle through the options with the ◀▶ buttons until you return to the regular operating mode.



You only need to make the distance settings if your system has surround speakers.

SETTING UP SPEAKER LEVELS FOR DOLBY PRO LOGIC

For the best surround sound, set up the relative speaker levels so that they all have the same volume from your normal listening position. Follow the steps:

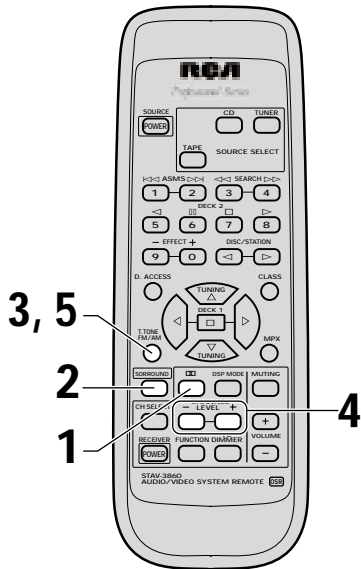

- 1 Press the **POWER** button.
- 2 Press the **SURROUND** button.
- 3 Press the **T.TONE** button.
A short test tone will be heard in turn from each speaker in your set up, except the subwoofer.
- 4 Adjust the respective speaker levels with the **CHANNEL LEVEL +/-** buttons when the TEST TONE sounds from that speaker.
Adjust the volumes of the speakers so that the volume of all speakers appears equal from your normal listening position.
- 5 Press **T.TONE** again.
When you are satisfied that the set up is complete, press the **T.TONE** button to return to normal operation.



- No TEST TONE sounds for the subwoofer
- These speaker level settings are applicable to PRO LOGIC, PRO LOGIC with THEATER 1 & PRO LOGIC with THEATER 2 settings.

SETTING UP SPEAKER LEVELS FOR DVD 5.1 CH

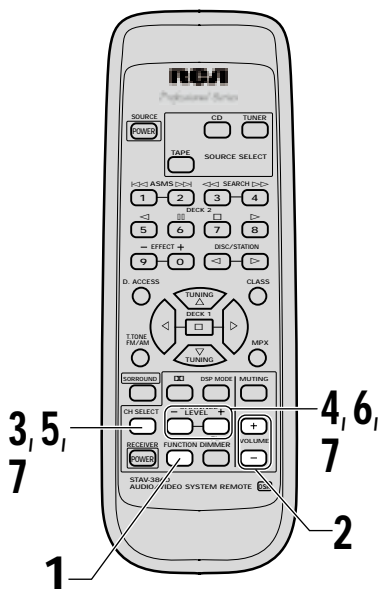

- 1 Use the **FUNCTION** button to select DVD 5.1 CH input mode.
- 2 Play a DVD 5.1 CH source and set the master volume to a moderate level.
- 3 Press the **CH SELECT** button.
The first speaker, **FL** (front left), and its relative volume level (+/- **dB) appears in the display.
- 4 Adjust the front left (**FL**) speaker level with the **CHANNEL LEVEL +/-** buttons.
Adjust the volumes of the speakers to a standard level of your choice when seated in your normal listening position.
- 5 Press **CH SELECT** again to move to the next speaker.
The second speaker **CT** (center) and its relative volume level (+/- **dB) appears in the display.
- 6 Adjust the center (**CT**) speaker level with the **CHANNEL LEVEL +/-** buttons.
Adjust the speaker volume so it seems the same as the previous speaker from your normal listening position.
- 7 Repeat steps 3 & 4 for all of your speakers.
Adjust the volumes of the all speakers so their volume seems the same from your normal listening position.

SETTING UP SPEAKER LEVELS FOR DSP

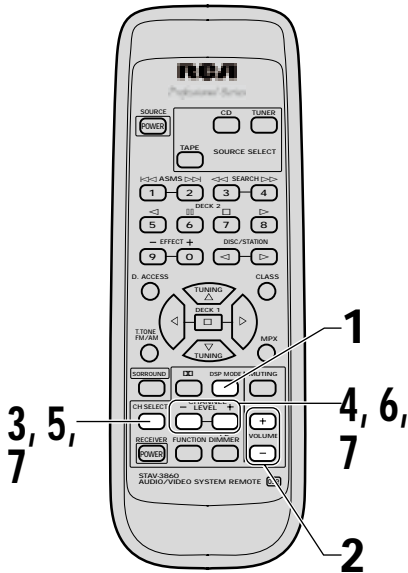

- 1 Use the **DSP MODE** button to turn on a DSP effect. You can cycle through the five different types with the **DSP** button.
- 2 Play a source (CD, tape, etc.) and set the master volume to a moderate level.
- 3 Press the **CH SELECT** button. The first speaker **FL** (front left) and its relative volume level (**+/- **dB**) appears in the display.
- 4 Adjust the front left (**FL**) speaker level with the **CHANNEL LEVEL +/-** buttons. Adjust the volumes of the speakers to a standard level of your choice when seated in your normal listening position.
- 5 Press **CH SELECT** again to move to the next speaker. The second speaker **CT** (center) and its relative volume level (**+/- **dB**) appears in the display.
- 6 Adjust the center (**CT**) speaker level with the **CHANNEL LEVEL +/-** buttons. Adjust the volume of the speaker so its volume seems the same as the previous speaker from your normal listening position.
- 7 Repeat steps 3 & 4 for all of your speakers. Adjust the volumes of all the speakers so their volume seems the same from your normal listening position.



- These speaker level settings are applicable to DSP effects only.
- Each effect level applies only to the DSP type (HALL for example) that it is set in. You can set the effect levels for each type independently.

DISPLAYS AND CONTROLS

FRONT PANEL

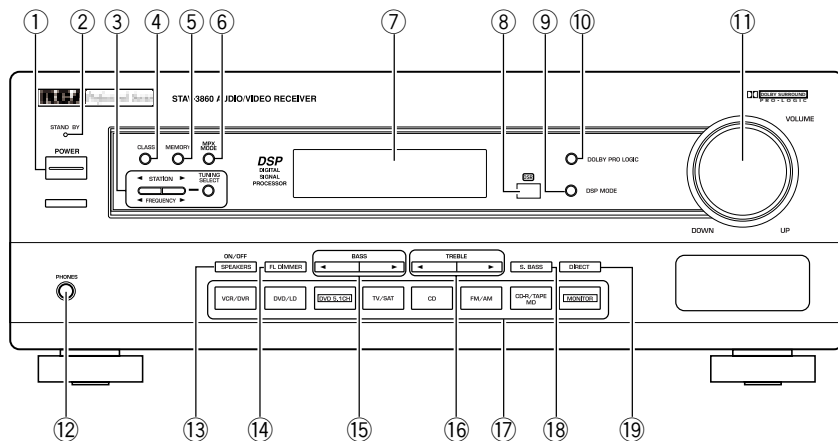

- ① **POWER button**
Switches the receiver between on and standby.
- ② **STANDBY indicator**
Lights when the receiver is in standby mode (note that the receiver consumes a small amount of power (1W) in standby mode).
- ③ **STATION <-> (-/+), FREQUENCY <-> (-/+), TUNING SELECT buttons**
STATION <-> (-/+) Selects station memories when using the tuner.
FREQUENCY <-> (-/+) Selects the frequency when using the tuner.
TUNING SELECT Switches between station memory and frequency select modes (see pages 23–25).
- ④ **CLASS button**
Switches between the three banks (classes) of station memories (see page 25).
- ⑤ **MEMORY button**
Press to memorize a station for recall using the STATION <-> buttons (see page 24).
- ⑥ **MPX MODE button**
If the **TUNED** or **STEREO** indicators don't light when tuning to an FM station because the signal is weak, press the MPX button to switch the receiver into mono reception mode. This should improve the sound quality and allow you to enjoy the broadcast (see page 23).
- ⑦ **Display** (see page 18)
- ⑧ **Remote sensor**
Receives the signals from the remote control.
- ⑨ **DSP MODE button**
Use to switch between the various DSP modes available (**HALL**, **JAZZ**, **DANCE**, **THEATER 1**, **THEATER 2**) and DSP off. Use to create different surround sound effects from any stereo source (see page 22).
- ⑩ **DOLBY PRO LOGIC button**
Use to switch between the various Pro Logic modes (PRO LOGIC, PRO LOGIC with THEATER 1, PRO LOGIC with THEATER 2) and Pro Logic off (see page 20).
- ⑪ **VOLUME**
Use to set the overall listening volume.
- ⑫ **PHONES jack**
Use to connect headphones but this does not switch the speakers off.
- ⑬ **SPEAKERS ON/OFF button**
Use to switch the speaker system on or off.
- ⑭ **FL DIMMER button**
Use this button to make the fluorescent display (FL) dimmer or brighter. There are three brightness settings as well as an off setting.
- ⑮ **BASS <-> (-/+) buttons**
Use to increase/decrease bass (within a range of -6dB to 6dB in 2dB steps). It cannot be used when S.BASS is on.
- ⑯ **TREBLE <-> (-/+) buttons**
Use to increase/decrease treble (within a range of -6dB to 6dB in 2dB steps).
- ⑰ **Function buttons**
Use to select a source for playback or recording.
- ⑱ **S.BASS button**
Use to switch on and off the bass boost. Use for a more powerful bass sound. Negates use of BASS buttons.
- ⑲ **DIRECT button**
Use to switch DIRECT playback on or off. This mode bypasses the tone controls and channel levels for the most accurate reproduction of a program source.

DISPLAY

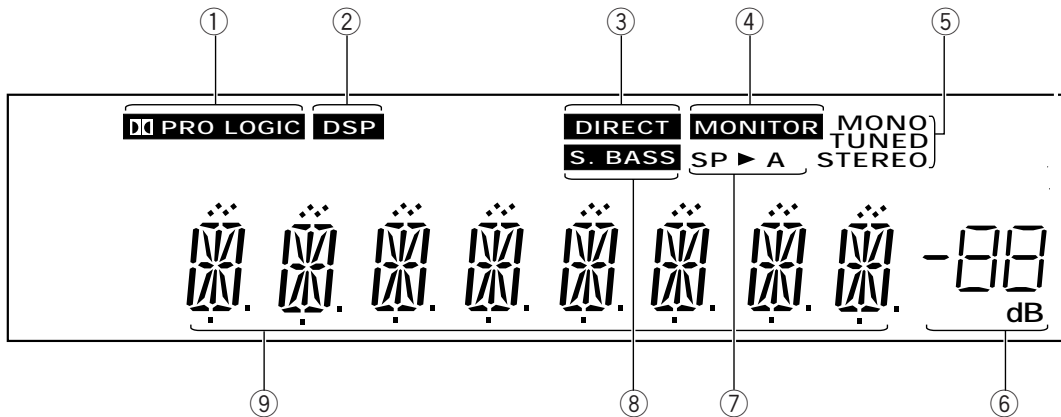

- ① **PRO LOGIC indicator**
Lights when any Dolby Pro Logic mode is selected.
The main character display briefly shows the current Pro Logic mode (**PRO LOGIC**, **THEATER 1**, **THEATER 2**) after selection (see page 20).
- ② **DSP indicator**
Lights when any DSP mode is selected. The main character display briefly shows the current DSP mode (**HALL**, **JAZZ**, **DANCE**, **THEATER1** and **THEATER 2**) after selection (see page 22).
- ③ **DIRECT indicator**
Lights when source DIRECT is on. This function bypasses all tone, balance, DSP and Dolby Surround effects.
- ④ **MONITOR indicator**
Lights when **MONITOR** is selected to hear a recording as it's being made (see page 26).
- ⑤ **TUNER indicators**
MONO:
Lights when the mono mode is set using the MPX MODE button (see page 23).
TUNED:
Lights when a broadcast is being received.
STEREO:
Lights when a stereo FM broadcast is being received in auto stereo mode.
- ⑥ **MASTER VOLUME LEVEL**
Shows the overall volume level. Volume level is maintained even when the power is off. **---**dB indicates the minimum level, and **0dB** indicates the maximum level.
 - Depending on the level settings for individual channels, the MAX level can range between **-10dB** and **0dB**.
- ⑦ **SPEAKER indicator**
Shows if the speaker system is on or not. If **SP ► A** appears, speakers are switched on. If **SP ►** appears, speakers are switched off.
- ⑧ **S. BASS indicator**
Lights when the S. BASS is on (see note ⑱ on page 17).
- ⑨ **CHARACTER display**
Shows the radio frequency or function (DVD/LD, CD, etc.) receiver is using .

REMOTE CONTROL

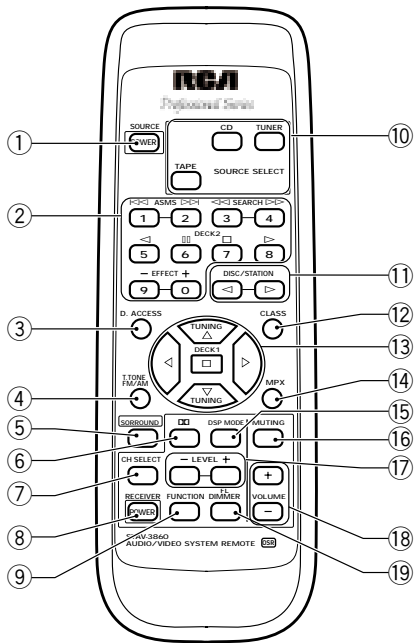

- ① **SOURCE (POWER) button**
- ② **NUMBER/PLAYER COMMAND buttons**
Use to select the radio frequency in tuner mode. Also, you can use to control RCA professional series components like CD players, cassette decks, etc. according to the commands printed above the button (4, 3, 7, etc.) (see pages 24, 27–29).
- ③ **D.ACCESS button**
This button gives you direct access to radio frequency input, allowing you to input a station directly. In DVD mode this button brings you to the top menu (see pages 24, 29).
- ④ **T.TONE / FM/AM button**
Use this button to hear a test tone from each speaker in turn to set the relative speaker volumes. Also switches the BAND in TUNER mode (see pages 15, 23–24).
- ⑤ **SURROUND button**
Use this button to set up the surround sound features of the STAV-3860. Use it to select the type of center mode, turn on/off subwoofer option and select delay time for each speaker, or to start the process of setting the effect levels (see pages 13, 15, 20, 22).
- ⑥ **DD button**
Use to select a Dolby Pro Logic mode. Also used to access Test Tone (see pages 15, 20).

- ⑦ **CH SELECT button**
Used to start the process of setting the speaker levels (see ⑩ below) (see pages 15–16).
- ⑧ **RECEIVER STANDBY/ON button**
Use to switch the receiver between on and standby modes.
- ⑨ **FUNCTION button**
Use to select the playback or recording source.
- ⑩ **SOURCE SELECT keys**
Use to put the remote control (NOT the receiver) in the stated mode.
For other equipment controls, see Controlling the Rest of Your System starting on page 27.
- ⑪ **DISC/STATION +/- buttons**
Use to select the station of memorized frequencies (see pages 25, 27).
- ⑫ **CLASS button**
Use to switch between the three banks (classes) of station memories (see page 25).
- ⑬ **◀▶ ▲▼ (TUNING +/-) and ■(ENTER) buttons**
Use these arrow buttons when setting up your surround sound system (see pages 13–16). These buttons are also used to control for deck 1 of a double cassette deck player. The **TUNING +/-** buttons can be used to find radio frequencies (see pages 13, 14, 23).
- ⑭ **MPX button**
Use to switch between auto stereo and mono reception of FM broadcasts. If the signal is weak then switching to **MONO** will improve the sound quality (see page 23).
- ⑮ **DSP MODE button**
Use to switch between the various DSP modes available (**HALL, JAZZ, DANCE, THEATER 1, THEATER 2**) and DSP off. Use to create different surround sound effects from any stereo source (see page 22).
- ⑯ **MUTING button**
Use to mute all audio without affecting any of the current sound settings.
- ⑰ **CHANNEL LEVEL +/- buttons**
Use to set the relative speaker volumes for all the speakers in your system (see ⑦ above) (see pages 15, 16).
- ⑱ **VOLUME +/- buttons**
Use to set the overall listening volume.
- ⑲ **FL DIMMER button**
Use this button to make the fluorescent display (FL) dimmer or brighter. There are three brightness settings as well as an off setting.

LISTENING IN SURROUND SOUND

LISTENING IN DOLBY PRO LOGIC MODE

To really appreciate what the STAV-3860 can do, sit back and experience a movie encoded in Dolby Digital or Dolby Surround with five speaker surround sound creating theater-like sound effects in your living room. When choosing software, look for the  **DOLBY SURROUND** mark on DVD discs, laser discs, and video tapes (sometimes, unmarked software is also recorded in Dolby Surround).

To enjoy Dolby Digital surround sound from DVD discs, you'll need to have connected your DVD player (or Dolby Digital decoder) to the receiver's 5.1 channel inputs (see page 10), and set the receiver to DVD 5.1CH input mode. See "Listening in DVD 5.1 Channel Input Mode" on page 21.

Many video tapes feature Dolby Surround/Pro Logic. The STAV-3860 takes advantage of this to provide dramatic and realistic surround sound. The effect can be further enhanced by choosing a Pro Logic with DSP mode. Follow the steps on this page when playing Dolby Surround or Dolby Pro Logic material.

When using any of these modes, it's really important that your speakers are set up correctly (see pages 11–12), and that you've worked through the steps in Setting Up for Surround Sound on pages 13–15.

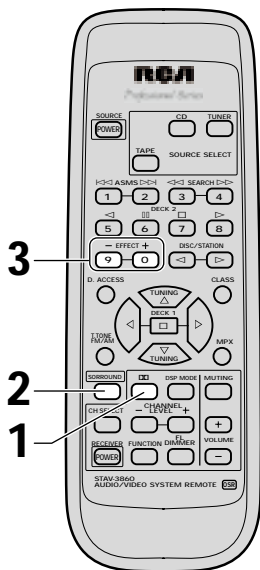

- 1 Press the  button (DOLBY PRO LOGIC on the receiver). Pressing repeatedly changes the Pro Logic mode in the following sequence:

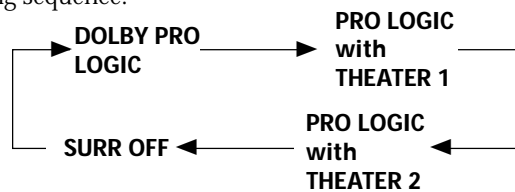

- 2 Press the **SURROUND** button. This starts the process of setting the effect level.
- 3 Use the **EFFECT +/-** to adjust the DSP effect level PRO LOGIC with THEATER 1 and PRO LOGIC with THEATER 2. You can adjust the effect level within an range of 10–90 (the default setting is 50).



- You need to input mode/distance/level settings specifically for your Pro Logic mode (see pages 13–15).
- If you turn the speakers off PRO LOGIC goes off as well. When you turn the speakers back on, PRO LOGIC will NOT go back on.
- If you try and turn PRO LOGIC on when the speakers are off, **SP OFF** will flash on the display, informing you that you can't turn on PRO LOGIC when the speakers are off.
- You can't use the tone controls, or the DIRECT function with PRO LOGIC mode.

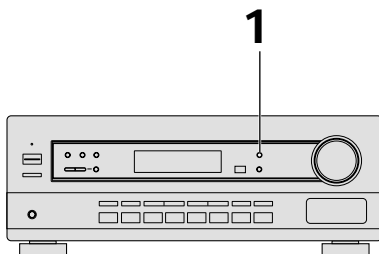

LISTENING IN DVD 5.1 CHANNEL INPUT MODE

You can use this feature if you have a DVD player and a Dolby Digital decoder or a DVD player with a built-in Dolby Digital decoder. Both these decoders will have separate analog audio outputs for the front left and right, center, surround left and right, and sub-woofer channels. Connect these to the 5.1 channel inputs of the STAV-3860 for enhanced playback of Dolby Digital material—see page 10 for instructions on connecting. 5.1 channel mode of the STAV-3860 provides better surround-channel sound and overall channel separation than the Dolby Pro Logic mode.

Follow the steps below to use the 5.1 channel mode.

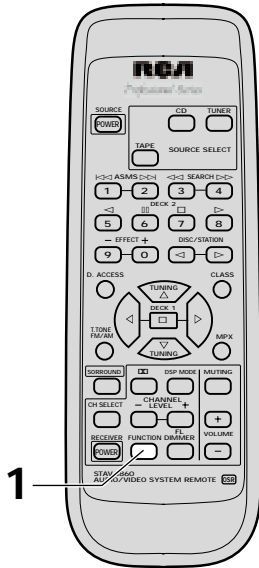

- 1 Use the **FUNCTION** button to select DVD 5.1 CH.
On the receiver, press the **DVD 5.1 CH** function button to select the DVD input mode directly.

On the remote control, repeated presses of the **FUNCTION** button switches between 5.1 channel input and the other inputs.



- You can input level settings specifically for the 5.1 CH mode to enhance your surround sound experience (see "Setting Up Speaker Levels for DVD 5.1CH" on page 15).
- The tone controls, S.BASS, or the DIRECT function are not available in 5.1 CH mode.

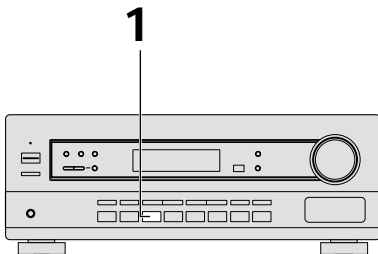

LISTENING IN DSP MODE

The DSP (Digital Signal Processing) modes transform your living room into a variety of different sound environments when playing standard (two channel) stereo sources. Optionally, you can adjust the amount of effect added to the source. The descriptions below give an idea of how the five different modes sound, but you might want to play a source and experiment.

HALL

Simulates the acoustic environment of a large classical concert hall. Long delay and reverb decay times create a sense of music being played in a large space.

JAZZ

Simulates the acoustic environment of a jazz club. Shorter delay times and a tighter reverb help to give the sound a live, small club feel.

DANCE

Simulates the acoustic environment and strong bass sound of a dance music club.

THEATER 1

Simulates the acoustic environment of a mid-sized movie theater.

THEATER 2

Similar to the above but maintains proper localization of each channel.

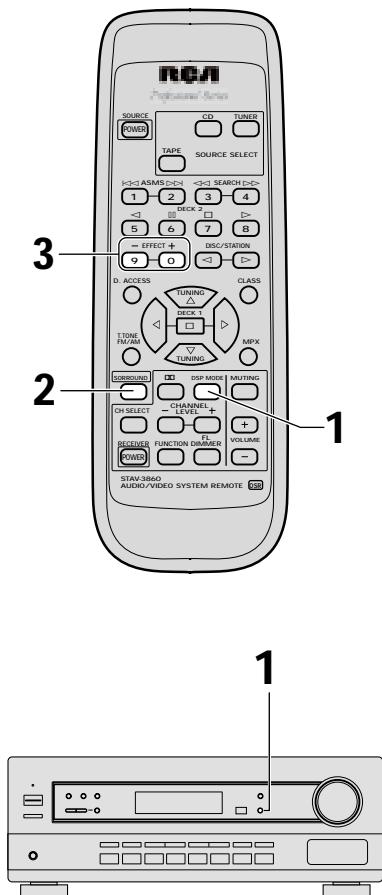

- 1 Use the **DSP MODE** button to select a DSP MODE. Repeated presses of **DSP MODE** changes the DSP mode in the following sequence:

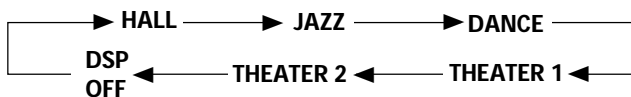

- 2 Press the **SURROUND** button.
- 3 Use the **EFFECT +/-** buttons to adjust the DSP effect level. You can adjust the effect level within an range of 10–90 (the default setting is 50).



- The settings for effect level in DSP mode are independent of the effect level in PRO LOGIC with THEATER 1 and PRO LOGIC with THEATER 2 modes.
- You can input level settings specifically for the DSP mode and this will enhance your surround sound experience (see page 16).
- If you turn on DSP when the speakers are off, **SP OFF** flashes, indicating DSP is not available when the speakers are off.
- You cannot use the tone controls or the DIRECT function with DSP mode.

USING THE TUNER

FINDING A STATION

Follow steps below to tune in to FM and AM radio broadcasts using the automatic (search) and manual (step) tuning functions. If you already know the exact frequency of the station you want to listen to, see Tuning Directly to a Station on the following page. Once you are tuned to a station you can memorize the frequency for recall later—see "Memorizing Stations" on page 24 for more on how to do this.

The receiver and the remote control must both be set to tuner mode for AM/FM station listening.

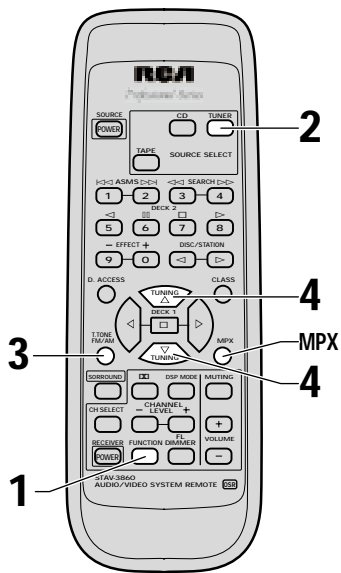

- 1 Use the **FUNCTION** button to put the receiver in tuner mode. On the receiver, press the **FM/AM** button to select the tuner mode.
- 2 Press the **TUNER** button on the remote control to put it in tuner mode.
- 3 Use the **FM/AM** button to change the band (FM or AM), if necessary. Each press switches the band between FM and AM (on the front panel use the **FM/AM** button).
- 4 Tune to a station.

Automatic Tuning

To search for stations in the currently selected band, press and hold either the **TUNING. +** or **TUNING. -** button for about a second. The receiver will start searching for the next station, stopping when it has found one. Repeat this step to search for other stations.

Manual Tuning

To change the frequency one step at a time, press the **TUNING. + / TUNING. -** (▲▼) buttons.

To change frequency more quickly, press and hold the **TUNING. + / TUNING. -** buttons until the desired frequency is reached, then release.

Once you've found a station, you can store it in the receiver's memory for easy recall anytime—see "Recalling Memorized Stations" on page 25.

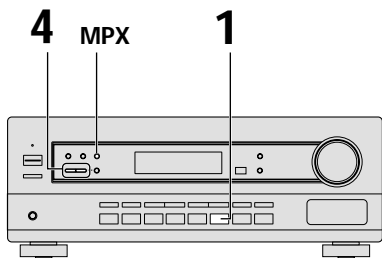

MPX Mode

If the **TUNED** or **STEREO** indicators don't light when tuning to an FM station because the signal is weak, press the **MPX** button to switch the receiver into mono reception mode. This should improve the sound quality and allow you to enjoy the broadcast.

Tuning Directly to a Station

If you know the frequency of the station you want to listen to, simply enter the frequency using the number buttons on the remote control. This function is not available using the front panel controls of the receiver.

The receiver and the remote control must both be set to tuner mode for AM/FM station listening.

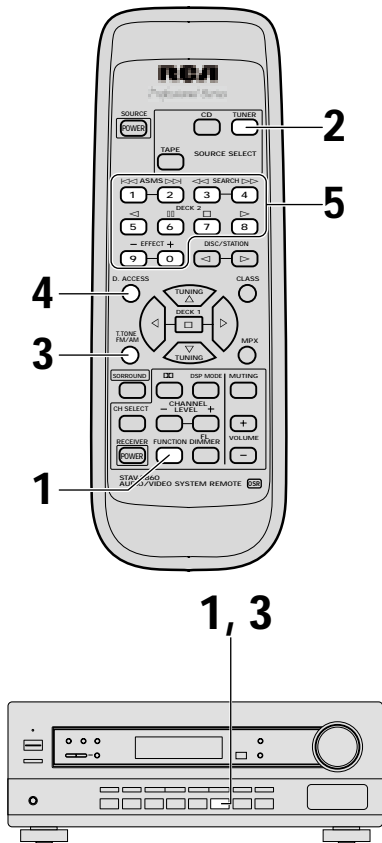

- 1 Use the **FUNCTION** button to put the receiver in tuner mode. On the receiver, press the **FM/AM** button to select the tuner mode.
- 2 Press the **TUNER** button on the remote control to put it in tuner mode.
- 3 Press the **FM/AM** button to select either FM or AM. Each press switches the band between FM and AM (on the front panel, use the **FM/AM** button).
- 4 Press **D.ACCESS** (DIRECT ACCESS).
- 5 Use the number buttons to enter the frequency of the radio station.

Example:

To tune to 106.00 (FM), press 1 - 0 - 6 - 0 - 0

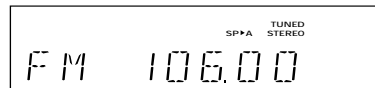

If you make a mistake while inputting the frequency, press the **D.ACCESS** button twice to cancel the frequency and start again.

MEMORIZING STATIONS (FRONT PANEL ONLY)

If you often listen to a particular radio station, it's convenient to have the receiver store the frequency for easy recall. The STAV-3860 can memorize up to 30 stations, stored in three banks, or classes, (A,B and C) of 10 stations each. When memorizing FM frequencies, the receiver also stores the MPX setting (auto stereo or mono, see "MPX Mode" on page 23). The process for memorizing stations is only possible from the controls on the front panel of the receiver.

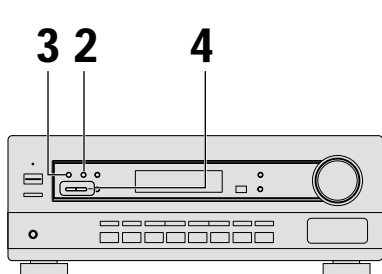

- 1 Tune to a station you want to store. See "Finding a Station" on page 23 and "Tuning Directly to a Station."
- 2 Press **MEMORY**. The display shows a blinking memory class.

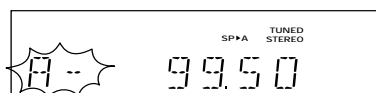

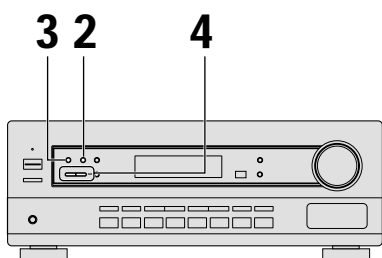

- 3 Repeatedly press **CLASS** to select one of the three classes.
- 4 Repeatedly press **STATION** ◀▶ to select the desired station memory number.

After choosing the location you want, the preset class and number blink for about 5 seconds and the receiver stores the station.

Repeat steps 1 to 4 to memorize up to 30 stations.

RECALLING MEMORIZED STATIONS

Having memorized up to 30 stations (see "Memorizing Stations" on page 24), you can listen to a station with a couple of button presses.

The receiver and the remote control must both be set to tuner mode for AM/FM station listening.

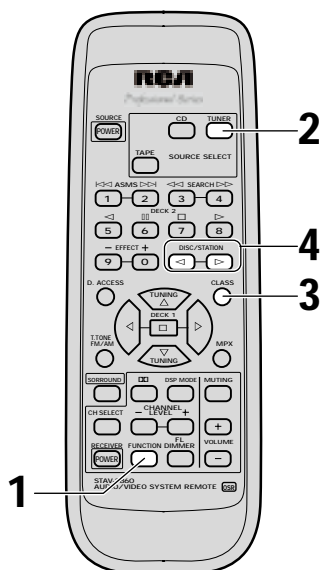

- 1 Use the **FUNCTION** button to put the receiver in tuner mode. On the receiver, press the **FM/AM** button to select the tuner mode.
- 2 Press the **TUNER** button on the remote control to put it in tuner mode.
- 3 Press **CLASS** to select the class in which the station is stored. Repeatedly pressing this button cycles through the three available classes, A, B and C.
- 4 Use the **STATION** ◀▶ buttons to select the station memory in which the station is stored. Alternatively, recall the station memory using the number buttons on the remote control.



If the receiver is left disconnected from the AC power outlet for a lengthy period, the station memories will be lost and will have to be reprogrammed.

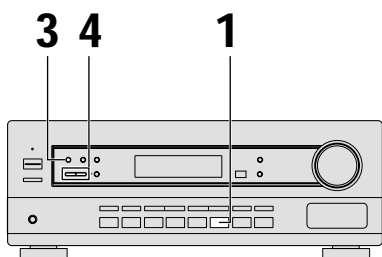

MAKING A RECORDING

MAKING AN AUDIO OR A VIDEO RECORDING

The following steps show you how to make an audio or a video recording from the built in tuner, or from an audio or video source connected to the receiver (such as a CD player or TV). Recordings can be made to a CD-Recorder, cassette deck, MD, VCR, or DVR deck connected to the CD-R/TAPE/MD, VCR or DVR in/out connectors.



The receiver's volume, balance tone (bass, treble, S.bass), and surround effects (Dolby Pro Logic and DSP settings) have no effect on the recorded signal.

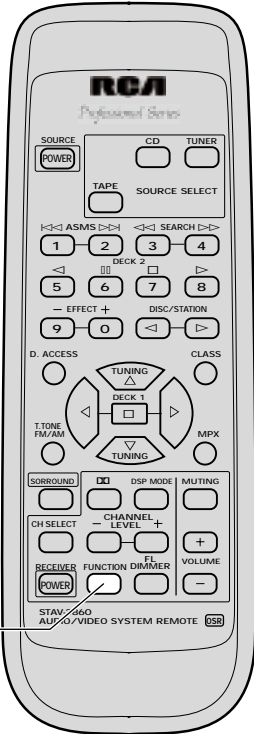

- 1 Press the **FUNCTION** button to select a source to record. All functions except **MONITOR** are accessible from the remote control. On the receiver, select the source directly using the front panel buttons.
- 2 Prepare the program source. Tune to the radio station, load the CD or other media.
- 3 Insert a blank tape or other media into the recording device connected to either CD-R/TAPE/MD or VCR/DVR and set the recording levels. Refer to the instructions that came with the recorder if you are unsure how to do this. Most video recorders set the audio recording level automatically—check your video's instruction manual if you are unsure whether yours has manual controls.
- 4 Start recording, then start playback of the source component.

Record **MONITOR**

You can listen to (monitor) the recording using the **MONITOR** button on the Front Panel (a cassette deck would have to have a record monitor function).

Press the **MONITOR** button to switch between the recorded signal and the original source signal.

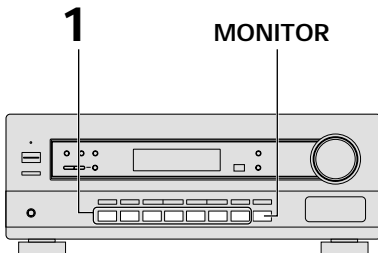

ADDITIONAL SYSTEM CONTROL

CD PLAYER CONTROLS



To control your CD player with this remote control, the remote must be in CD mode with the proper **SOURCE SELECT** button.

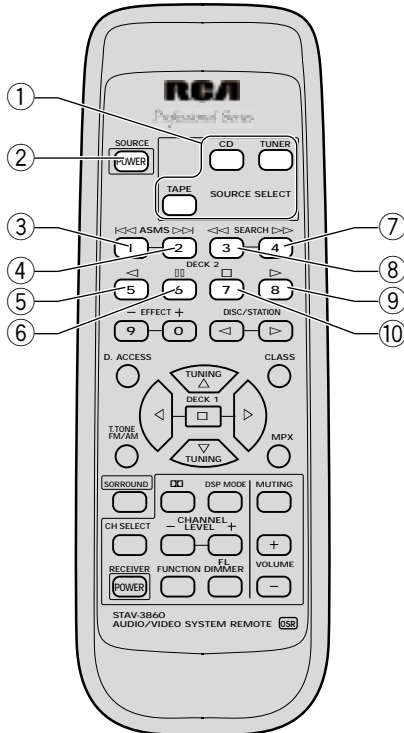

- ① Use **SOURCE SELECT** buttons to put the remote control in the CD mode.
- ② **SOURCE (POWER)**
Press to switch the CD player between STANDBY and ON.
- ③ Press to return to the start of the current track. Repeated presses skips to the start of previous tracks.
- ④ Press to advance to the start of the next track. Repeated presses skips to the start of following tracks.
- ⑤ This button has no function.
- ⑥ Press to pause playback.
- ⑦ Hold down for fast forward playback.
- ⑧ Hold down for fast reverse playback.
- ⑨ Press to start playback.
- ⑩ Press to stop playback (on some models, pressing this when the disc is already stopped will cause the disc tray to open).

CASSETTE DECK CONTROLS



To control your cassette deck with this remote control, the remote must be in the TAPE mode with the **TAPE SOURCE SELECT** button.

For regular cassette decks use buttons ③–⑩ below for the tape control functions. For double deck models, use buttons ③–⑩ to control deck 2 and buttons ⑪–⑫ to control deck 1.

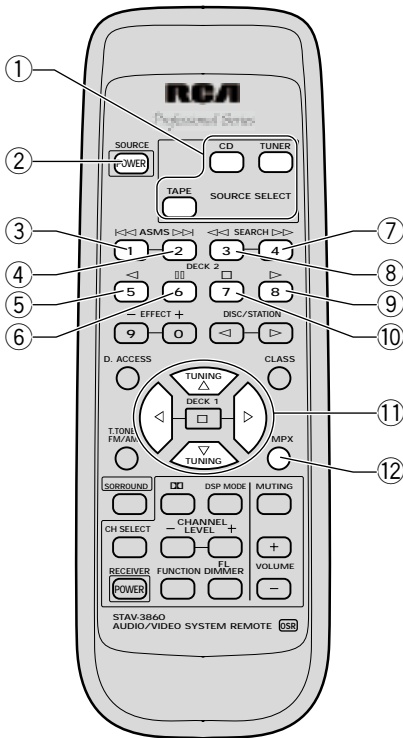

- ① Use **SOURCE SELECT** buttons to put the remote control in the tape mode.
- ② **SOURCE (POWER)**
Press to switch the cassette deck between STANDBY and ON (not possible on all models).
- ③ ◀◀
This button has no function in cassette deck mode.
- ④ ▶▶
This button has no function in cassette deck mode.
- ⑤ ◀
Press to start playback of reverse side of tape (auto reverse models only).
- ⑥ ||
Press to pause playback or recording.
- ⑦ ▶▶▶
Press to fast forward the tape. Pressing during playback starts forward search.
- ⑧ ◀◀◀
Press to rewind the tape. Pressing during playback starts reverse search.
- ⑨ ▶
Press to start playback.
- ⑩ ■
Press to stop playback.
- ⑪ ▲ (▶▶▶) :
Press to fast forward the tape. Pressing during playback starts forward search.
▼ (◀◀◀) :
Press to rewind the tape. Pressing during playback starts reverse search.
ENTER (■) : Press to stop playback.
◀ : Press to start playback of reverse side of tape (auto- reverse models only).
▶ : Press to start playback.
- ⑫ **MPX (||)**
Press to pause playback or recording.

ADDITIONAL INFORMATION

TROUBLESHOOTING

This receiver has been manufactured to the specifications of RadioShack and is covered by a limited warranty from RadioShack. If your receiver is not operating as it should, take it to your local RadioShack store or call 1-800-THE-SHACK for assistance.

Incorrect operation is often mistaken for trouble and malfunctions. If you think that there is something wrong with this component, check the points below. Sometimes the trouble may lie in another component. Investigate the other components and electrical appliances being used.

Symptom	Cause	Remedy
The power does not turn on.	<ul style="list-style-type: none"> The power plug is disconnected. The protection circuit may have activated. 	<ul style="list-style-type: none"> Connect the power plug to the wall outlet. Disconnect the power plug from the outlet, and insert again.
The unit does not respond when the buttons are pressed.	<ul style="list-style-type: none"> Static electricity caused by dry air. 	<ul style="list-style-type: none"> Disconnect the power plug from the outlet, and insert again.
No sound is output when a function is set.	<ul style="list-style-type: none"> Improper connections. Sound is muted. The volume is turned down. Speakers are turned off. Monitor is on. 	<ul style="list-style-type: none"> Make sure the component is connected correctly (see pages 8 through 11). Press MUTING on the remote control. Adjust VOLUME. Press SPEAKERS to switch on the speakers. Press the MONITOR button.
No image is output when a function is set.	<ul style="list-style-type: none"> Improper connections. The input source is not properly selected. 	<ul style="list-style-type: none"> Make sure the component is connected correctly (see "Connecting Your System" on pages 8 through 11). Press the correct function button.
Considerable noise in radio broadcasts	<ul style="list-style-type: none"> Incorrect frequency. The antenna is not connected. 	<ul style="list-style-type: none"> Tune in the correct frequency. Connect the antenna (see "Connecting Antennas" on page 8).
	FM broadcasts	
	<ul style="list-style-type: none"> The FM antenna is not fully extended or poorly positioned. Weak radio signal. 	<ul style="list-style-type: none"> Fully extend the FM wire antenna, position for best reception, and secure to a wall. Connect an outdoor FM antenna. (see "Connecting Antennas" on page 8).
	AM broadcasts	
	<ul style="list-style-type: none"> The AM antenna is poorly positioned. Weak radio signal. Interference caused by other equipment (fluorescent lamp, motor, etc.). 	<ul style="list-style-type: none"> Adjust the direction and position for best reception. Connect an additional internal or external AM antenna (see "Connecting Antennas" on page 8). Turn off the equipment causing the noise or move it away from the receiver. Place the antenna farther away from the equipment causing the noise.
Broadcast stations cannot be selected automatically.	<ul style="list-style-type: none"> Weak radio signal. 	<ul style="list-style-type: none"> Connect an outdoor antenna (see "Connecting Antennas" on page 8).
No sound from surround or center speakers.	<ul style="list-style-type: none"> Incorrect center mode. The surround and/or center levels are turned down. The surround and/or center speakers are disconnected. 	<ul style="list-style-type: none"> Set the correct center mode according to the speakers in your system (see "Setting Up for Surround Sound" on page 13). See "Setting Volume Levels" on page 15–16 to check the speaker levels. Connect the speakers (see "Connecting Speakers" on pages 11–12).

Symptom	Cause	Remedy
Cannot be remote controlled.	<ul style="list-style-type: none"> • The remote control unit's batteries have worn out. • Too far away or bad angle of operation. • There is an obstacle between the receiver and the remote control. • Strong light such as fluorescent light is shining onto the unit's remote control signal light receiving window. 	<ul style="list-style-type: none"> • Replace the batteries (see "Preparing the Remote Control" on page 7). • Operate within 7 m, 30° of the remote sensor on the front panel (see "Preparing the Remote Control" on page 7). • Remove the obstacle or operate from another position. • Avoid exposing the remote sensor on the front panel to direct light.

If the unit does not operate normally due to external effects such as static electricity, disconnect the power plug from the outlet and insert again to return to normal operating conditions.

SPECIFICATIONS

Amplifier Section

Continuous average power output of 60 watts* per channel, min., at 8 ohms, from 40 Hz to 20,000 Hz with no more than 0.09 % total harmonic distortion (front).**

Continuous Power Output

Front	60 W + 60 W (1kHz, 0.9 %, 8 Ω)
Center	60 W (1kHz, 0.9 %, 8 Ω)
Surround	60 W + 60 W (1kHz, 0.9 %, 8 Ω)

Input (Sensitivity/Impedance)

CD, VCR/DVR, CD-R/TAPE/MD, DVD/LD, TV/SAT	200 mV/47 kΩ
---	--------------

Frequency Response

CD, VCR/DVR, CD-R/TAPE/MD, DVD/LD, TV/SAT	5 Hz to 100,000 ⁺⁰ ₋₃ Hz
---	--

Output (Level/Impedance)

VCR/DVR REC, CD-R/TAPE/MD REC	200 mV/2.2 kΩ
-------------------------------	---------------

Tone Control

BASS	± 6 dB (100 Hz)
TREBLE	± 6 dB (10 kHz)
S.BASS	+ 8 dB (100 Hz)

Signal-to-Noise Ratio (IHF short circuited, A network)

CD, VCR/DVR, CD-R/TAPE/MD, DVD/LD, TV/SAT	96 dB
---	-------

Signal-to Noise Ratio [EIA, at 1 W (1 kHz)]

CD, VCR/DVR, CD-R/TAPE/MD, DVD/LD, TV/SAT	79 dB
---	-------

* Measured pursuant to the Federal Trade Commission's Trade Regulation rule on Power Output Claims for Amplifiers.

** Measured by Audio Spectrum Analyzer.

Video Section

Input (Sensitivity/Impedance)

VCR/DVR, DVD/LD, TV/SAT	1 Vp-p/75 Ω
-------------------------------	-------------

Output (Level/Impedance)

VCR/DVR	1 Vp-p/75 Ω
---------------	-------------

Frequency Response

VCR/DVR, DVD/LD, TV/SAT → MONITOR	5 Hz to 7 MHz ⁺⁰ ₋₃ dB
-----------------------------------	--

Signal-to-Noise Ratio

Cross Talk

FM Tuner Section

Frequency Range

Usable Sensitivity

Mono:13.2 dBf, IHF (1.3 μV/75 Ω)

50 dB Quieting Sensitivity

Mono: 20.2 dB

Stereo: 38.6 dBf

Signal-to-Noise Ratio

Mono: 76 dB (at 85 dBf)

Stereo: 72 dB (at 85 dBf)

Distortion

Stereo: 0.5 % (1 kHz)

Alternate Channel Selectivity

60 dB (400 kHz)

Stereo Separation

40 dB (1 kHz)

Frequency Response

30 Hz to 15 kHz (±1) dB

Antenna Input

75 Ω unbalanced

AM Tuner Section

Frequency Range

530 kHz to 1,700 kHz

Sensitivity (IHF, Loop antenna)

350 μV/m

Selectivity

25 dB

Signal-to-Noise Ratio

50 dB

Antenna

Loop antenna

Miscellaneous

Power Requirements

AC 120 V, 60 Hz

Power Consumption

180 W

In Standby

1 W

Dimensions

16-9/16 (W) x 6-4/16 (H) x 15-7/16 (D) in.

(420 (W) x 158 (H) x 391 (D) mm)

Weight (without package)

18 lb 9 oz (8.4 kg)

Furnished Parts

FM Antenna

1

AM Loop Antenna

1

Remote Control Unit

1

Operating Instructions

1

NOTE:

Specifications are typical, individual units might vary. Specifications are subject to change and improvement without notice.

Limited Two-Year Warranty

This product is warranted by RadioShack against manufacturing defects in material and workmanship under normal use for two (2) years from the date of purchase from RadioShack company-owned stores and authorized RadioShack franchisees and dealers. EXCEPT AS PROVIDED HEREIN, RadioShack MAKES NO EXPRESS WARRANTIES AND ANY IMPLIED WARRANTIES, INCLUDING THOSE OF MERCHANTABILITY AND FITNESS FOR A PARTICULAR PURPOSE, ARE LIMITED IN DURATION TO THE DURATION OF THE WRITTEN LIMITED WARRANTIES CONTAINED HEREIN. EXCEPT AS PROVIDED HEREIN, RadioShack SHALL HAVE NO LIABILITY OR RESPONSIBILITY TO CUSTOMER OR ANY OTHER PERSON OR ENTITY WITH RE-SPECT TO ANY LIABILITY, LOSS OR DAMAGE CAUSED DIRECTLY OR INDIRECTLY BY USE OR PERFORMANCE OF THE PRODUCT OR ARISING OUT OF ANY BREACH OF THIS WARRANTY, INCLUDING, BUT NOT LIMITED TO, ANY DAMAGES RESULTING FROM INCONVENIENCE, LOSS OF TIME, DATA, PROPERTY, REVENUE, OR PROFIT OR ANY INDIRECT, SPECIAL, INCIDENTAL, OR CONSEQUENTIAL DAMAGES, EVEN IF RadioShack HAS BEEN ADVISED OF THE POSSIBILITY OF SUCH DAMAGES.

Some states do not allow the limitations on how long an implied warranty lasts or the exclusion of incidental or consequential damages, so the above limitations or exclusions may not apply to you. In the event of a product defect during the warranty period, take the product and the RadioShack sales receipt as proof of purchase date to any RadioShack store. RadioShack will, at its option, unless otherwise provided by law: (a) correct the defect by product repair without charge for parts and labor; (b) replace the product with one of the same or similar design; or (c) refund the purchase price. All replaced parts and products, and products on which a refund is made, become the property of RadioShack. New or reconditioned parts and products may be used in the performance of warranty service. Repaired or replaced parts and products are warranted for the remainder of the original warranty period. You will be charged for repair or replacement of the product made after the expiration of the warranty period.

This warranty does not cover: (a) damage or failure caused by or attributable to acts of God, abuse, accident, misuse, improper or abnormal usage, failure to follow instructions, improper installation or maintenance, alteration, lightning or other incidence of excess voltage or current; (b) any repairs other than those provided by a RadioShack Authorized Service Facility; (c) consumables such as fuses or batteries; (d) cosmetic damage; (e) transportation, shipping or insurance costs; or (f) costs of product removal, installation, set-up service adjustment or reinstallation.

This warranty gives you specific legal rights, and you may also have other rights which vary from state to state.

RadioShack Customer Relations, 200 Taylor Street, 6th Floor, Fort Worth, TX 76102

We Service What We Sell

09/99

RadioShack
A Division of Tandy Corporation
Fort Worth, Texas 76102