



# Procedures for Gas-Fired Furnaces

## INTRODUCTION

**The Need for Adequate Combustion Air** — Modern construction methods involve greater use of insulation, improved vapor barriers and weather-stripping, with the result that both apartments and single-family residences generally are much tighter structurally than they have been in the past. Combustion air supply for gas-fired equipment can be affected by these construction conditions, because infiltration that existed in the past may not now be adequate. Extensive use of kitchen and bathroom exhaust fans, and even fireplaces, aggravates the situation.

Today's building practices invalidate the old rule of thumb of "one air change by infiltration." Reliance on this practice can result in combustion air starvation if proper combustion air is not provided. In fact, recent field investigations, particularly with closet installation of gas-fired furnaces, indicate the need for positive provision for combustion air and for a better understanding of application guidelines that relate to today's conditions.

These instructions cover *minimum* combustion air requirements and venting practices, reflect current conditions found in the field, and conform to existing national standards and safety codes. In some instances, these instructions exceed certain local codes and ordinances, especially those that may not have kept pace with the changing residential construction practices. *Carrier requires these standard procedures as a minimum for a safe installation.*

**CAUTION:** Do not obstruct openings in front of the furnace or in the top on each side of the vent pipe. These provide air for combustion and ventilation. Never store anything on or in contact with the furnace such as:

Spray or aerosol cans, rags, brooms, dust mops, vacuum cleaners, or other cleaning tools.

Soap powders, bleaches, waxes or other cleaning compounds, plastic or plastic containers, gasoline, kerosene, cigarette lighter fluid, dry cleaning fluids, or other volatile fluids.

Paint thinners and other painting compounds, paper bags or other paper products.

**Installation Procedures** — The following recommendations apply to the installation and operation

of gas furnaces and piping systems for natural and LP gases. *Use these procedures in conjunction with the specific furnace installation instructions.*

Refer also to the regulations of the serving gas supplier and the local building, heating, plumbing or other codes in effect in the area in which the installation is made.

Portions of the following have been adopted in part from the "National Fuel Gas Code" (NFPA → No. 54-1980 or ANSI Z223.1-1980) copyrighted by the National Fire Protection Association and American Gas Association. For further details, consult this publication or current edition available from NFPA, 470 Atlantic Avenue, Boston, MA 02210, or American Gas Association, 1515 Wilson Boulevard, Arlington, VA 22209.

These instructions contain the following sections:

	Page
Inspection .....	1
Location and Air for Combustion and Ventilation .....	1
Gas Piping .....	4
Venting .....	4
Electrical .....	5
Start-Up, Adjustment, and Safety Check ....	5
Furnace Location with Respect to Cooling Equipment .....	7
Special Locations .....	7

## INSPECTION

Check the available power supply to be sure that it meets the specifications on the wiring diagram and all motors in the furnace.

Check the available gas supply to see that it conforms to the gas specification on the AGA rating plate.

## LOCATION AND AIR FOR COMBUSTION AND VENTILATION

Locate the furnace close to the chimney and as near the center of the air distribution system as possible. Provide ample space for servicing and cleaning. *Always comply with minimum fire protection clearances shown on the unit rating plate.* Do not install directly on carpeting, tile or any combustible material other than wood flooring. If base for combustible floor is required, obtain from Carrier distributor or dealer.

The draft hood relief air supply must be in the same atmospheric pressure zone as the combustion air inlet supply to the furnace.

When a furnace is installed so that supply ducts carry air to areas outside the space containing the furnace, the return air must also be handled by duct(s) sealed to the furnace casing and terminating outside the space containing the furnace.

All fuel-burning equipment must be supplied with air, which enters into the combustion process and is then vented to the outdoors. Sufficient air must enter the equipment room to replace that drawn up the vent stack. Replacement air must be provided by means of ducts from the outside to the equipment location or conditioned space. Under all conditions, enough air *must* be provided to ensure there will not be a negative pressure condition within the equipment room or space. A positive seal *must* be made between the furnace base and platform or return-air duct connections. Even a "slight" leak can create a negative pressure condition in a confined closet or basement, and affect combustion. If necessary, seal the furnace base to floor opening with fiberglass or other approved material. Furnaces with side-connected returns should utilize an accessory bottom closure, properly sealed.

Complete combustion requires approximately 10 cu ft of air for every 1000 Btu of gas fuel. In addition, approximately 10 more cu ft of air is required for draft hood dilution, and 10 more for ventilation of the furnace enclosure. Thus, for each 1000 Btu of gas consumed, a total of 30 cu ft of air must be supplied. For a 100,000 Btuh gas furnace, this equals 3000 cu ft of air per hour (100 x 30) or 50 cu ft of air per minute (3000 ÷ 60). In the past, the infiltration of outside air assumed in heat loss calculations (one air change per hour) was assumed to be sufficient. However, current construction methods, utilizing more insulation and vapor barriers, tighter fitting and gasketed doors and windows or weatherstripping, and the presence of fuel-burning fireplaces and mechanical exhaust fans from kitchens, laundries, and baths require the positive introduction of outside air.

**CAUTION:** Combustion air must come from a source that is not contaminated by halogens, which include fluorides, chlorides, bromides, and iodides. These elements are found in aerosol sprays, detergents, bleaches, cleaning solvents, salts, air fresheners, and other household products. Vapors from these products are highly corrosive to gas-fired furnaces, in even extremely low concentrations — as low as 1/2 part per million. When such contaminants are present, outside air *must* be ducted separately to the furnace room.

Operation of exhaust fans, kitchen ventilation systems, clothes dryers, or fireplaces may create

conditions requiring special attention to avoid unsatisfactory operation of installed gas furnaces. Commonly used exhaust fans and range hoods handle anywhere from 60 to 300 cfm (or more) and gas or electric clothes dryers may remove more air. With multiple use of such appliances common in both old and new homes and apartments, special provisions for positive introduction of outside air are mandatory. This air requirement is several times that required by the furnace, and must be replaced, in addition to the air required by the furnace.

→ The requirements for combustion and ventilation air depend upon whether the furnace is located in a *confined* or *unconfined* space. An unconfined space is defined as a space with a volume not less than 50 cu ft/1000 Btuh of the total input rating of all appliances installed in that space. Rooms communicating directly with the space in which the appliances are installed, thru openings not furnished with doors, are considered a part of the unconfined space.

A confined space is defined as a space with a volume less than 50 cu ft/1000 Btuh of the total input ratings of all appliances installed in that space.

### **Furnaces in Confined Spaces (Typical Furnace Closet)**

#### **ALL AIR FROM INSIDE BUILDINGS:**

The confined space shall be provided with 2 permanent openings, one beginning within 12 in. of the top and one beginning within 12 in. of the bottom of the enclosure. Each opening shall have a minimum free area of 1 sq in. per 1000 Btuh of the total input rating of all equipment in the enclosure, but not have less than 100 sq inches. The openings must freely communicate with interior areas served by the furnace, either thru permanent openings or louvered doors.

→ In addition, if building is of unusually tight construction, provide one permanent opening directly communicating with outdoors. This opening shall have a minimum free area of 1 sq in. per 5000 Btuh of total input rating of all equipment in the enclosure. Ducts shall be used to convey makeup air and shall be of the same cross-sectional area as the free areas of the openings to which they connect. This duct should be connected to the cold air return of the heating system. The minimum dimension of the rectangular air ducts should not be less than 3 inches. See Fig. 1.

If the furnace is installed on a raised platform to provide a return air plenum, and return air is taken directly from the hallway or space adjacent to the furnace, all air for combustion must come from outdoors, as prescribed below.

#### **ALL AIR FROM OUTDOORS:**

The confined space shall be provided with 2 permanent openings, one commencing within 12 in. of the top and one commencing within 12 in. of the

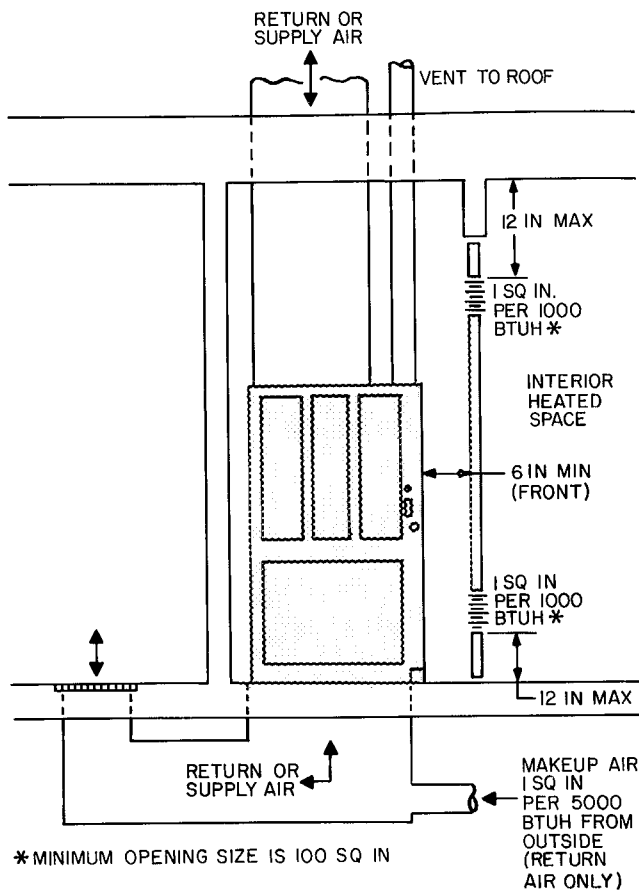

**Fig. 1 — Upflow or Counterflow, Using Air from Inside Building**

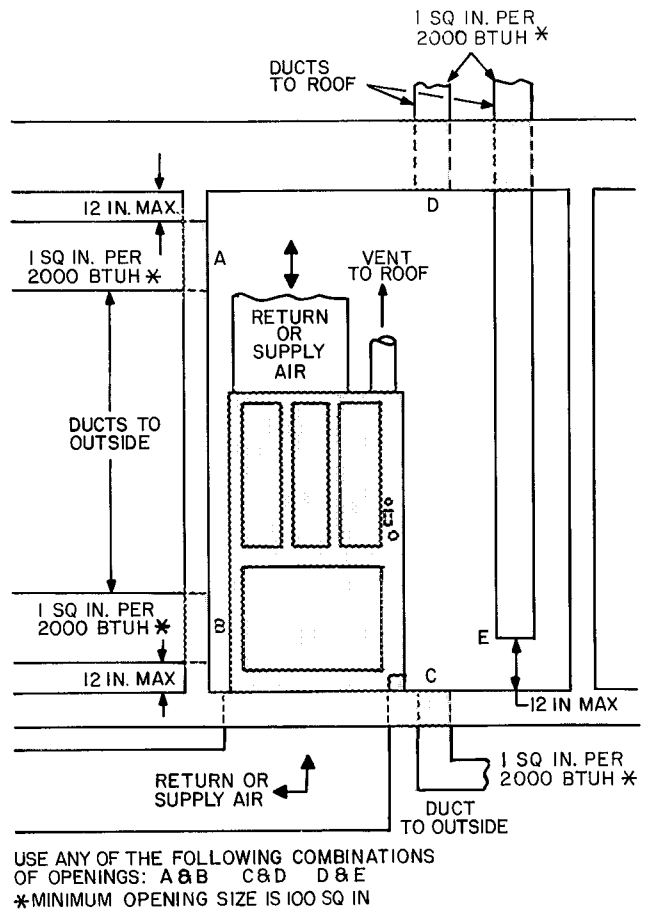

**Fig. 2 — Upflow or Counterflow, Using Air from Outside Building**

bottom of the enclosure. These openings shall communicate directly, or by ducts, with outdoors. See Fig. 2.

- a. When communicating with the outdoors thru horizontal ducts, each opening shall have minimum free area of 1 sq in. per 2000 Btuh of total input rating for all equipment in the enclosure. If vertical ducts or openings with louvers and grilles are used, each opening or duct shall have a minimum free area of 1 sq in. per 4000 Btuh of the total rated input of all equipment in the enclosure.
- b. When ducts are used, they shall be of the same cross-sectional area as the free area of the openings to which they connect. The minimum dimension of rectangular air ducts shall not be less than 3 inches.

**Furnaces in Unconfined Spaces (Basements, Large Equipment Rooms, etc.)** — If the unconfined space is within a building of unusually tight construction, air for combustion, ventilation, and dilution of flue gases shall be obtained from outdoors or from spaces freely communicating with the outdoors. A permanent opening, or openings, having a total free area of not less than 1 sq. in. per 5000 Btuh of total input rating for all equipment shall be provided. A duct may be used to convey

makeup air from the outdoors and shall be of the same cross-sectional area as the free area of the openings to which it connects. The duct may be connected to the cold air return of the heating system *only if it connects directly to outside air*. The minimum dimension of rectangular air ducts shall be not less than 3 inches.

**CAUTION:** Return air *must not* be taken from the room, unless an equal or greater amount of air is supplied to the room. All duct connections to the furnace must be airtight to avoid causing a “negative” pressure condition within the room.

**Louvers and Grilles** — In calculating the free area, consideration shall be given to the blocking effect of louvers, grilles, or screens protecting openings. Screens used must not be smaller than 1/4-in. mesh. If the free area thru a design of louver or grille is known, it should be used in calculating the size opening required to provide the free area specified. If the design and free area is not known, assume that wood louvers will have 20- to 25-percent free area and metal louvers and grilles will have 60- to 75-percent free area. Louvers and grilles that provide combustion and dilution air must be constructed so they cannot be closed.

## GAS PIPING

The gas supply line should be a separate line directly from the meter to the furnace, if possible. Refer to Table 1 for recommended gas pipe sizing. Do not use cast-iron or galvanized pipe.

**Table 1 — Maximum Capacity of Gas Pipe\***

NOMINAL IRON PIPE SIZE (in.)	INTERNAL DIAMETER (in.)	LENGTH OF PIPE (ft)				
		10	20	30	40	50
1/2	0.622	175	120	97	82	73
3/4	0.824	360	250	200	170	151
1	1.049	680	465	375	320	285
1-1/4	1.380	1400	950	770	660	580
1-1/2	1.610	2100	1460	1180	990	900

\*Cu ft of gas per hour for gas pressures of 0.5 psig or less, and a pressure drop of 0.5 in. wg (based on a 0.60 specific gravity) Ref Table C-4 NFPA 54-1980

Avoid low spots in long runs of pipe. It is best to slope all pipe 1/4 in. in 15 ft to prevent traps. All horizontal runs should slope away from the meter, to risers. Risers should be used to connect to the furnace and to the meter.

Joint compounds (pipe dope) should be applied sparingly and only to the male threads of the joints (omit the first 2 threads). Consult local supplier for type of compound to be used. This pipe dope must be resistant to the action of LP gas.

Install a sediment trap in the riser leading to the furnace. This trap will collect dirt or condensate. It can be installed by connecting a tee to the riser leading to the furnace, so that the straight-thru section of the tee is vertical. Then connect a capped nipple into the lower end of the tee. The capped nipple should extend below the level of the gas controls. See Fig. 3. Where a gum filter is required by local codes, install it in accordance with those requirements.

→ An accessible manual shutoff valve shall be installed upstream of the furnace gas controls and within 6 ft of the furnace. A 1/8-in. NPT plugged tapping, accessible for test gage connection, must be installed immediately upstream of the gas supply connection to the furnace and downstream from the manual shutoff valve.

Place a ground joint union between the gas control manifold and the manual gas shutoff valve, or use an approved flexible or semirigid conductor.

Support all piping with the appropriate straps, hangers, etc. (one hanger every 10 ft minimum).

→ Piping should be pressure-tested before any furnace, appliance, or shutoff valve is attached, in accordance with the requirements of local and national plumbing and gas codes.

If the pressure exceeds 0.5 psig, the gas supply pipe must be disconnected from the furnace before the pressure test. If the test pressure is equal to or less than 0.5 psig, close the manual shutoff valve

located on the gas valve before the test. It is recommended that the ground joint union be cracked before pressure testing.

After all connections have been made, purge the lines and check for leakage.

**WARNING:** Never purge a line into a combustion chamber. Never use matches, candles, flame or other sources of ignition for the purpose of checking leakage. Use a soap-and-water solution to check for leakage.

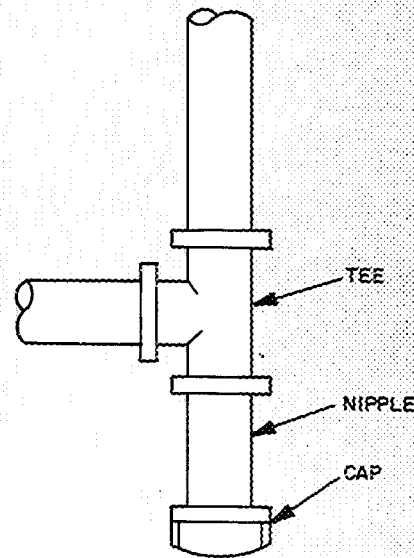

**Fig. 3 — Sediment Trap**

## VENTING

Consult local codes. For additional information refer to the "National Fuel Gas Code" (NFPA No. 54-1980 or ANSI Z223.1-1980). Unless the local codes direct otherwise, the unit may be vented to a permanent chimney, or to a listed type-B1 gas vent. All gas-fired furnaces are shipped with draft diverters; therefore, connect the vent collar to the chimney or gas vent to be used. The following recommendations are made:

1. Select flue connection material that is satisfactory for installation and that meets requirements of local codes.
2. Flue connection pipe must be at least as large as outlet collar on furnace. *No reduction in this size is permissible in pipe run.*
3. Run pipe as directly as possible with minimum number of turns.
4. Maintain minimum of 1/4 in. per linear ft upward slope on all horizontal runs.
5. Rigidly support flue pipe with hangers and straps to ensure that there will no movement after installation.

- 6. Insert the smallest flue connection pipe at the highest level consistent with available headroom or clearance to combustible materials, when 2 or more vent connectors enter a common gas vent or chimney flue.
- 7. Extend flue connection pipe thru chimney wall, flush with inner face of chimney liner and above extreme bottom to avoid restriction.

**WARNING:** Never connect into a chimney serving an open fireplace unless fireplace opening is sealed off.

- 8. No portion of the venting system shall extend into or pass thru any circulating air duct or plenum.
- 9. Chimney or gas vent should extend at least 5 ft above highest connected draft hood and should extend high enough above roof of any neighboring obstruction so that wind from any direction will not create positive pressure in vicinity of a chimney or gas vent outlet. Chimney or gas vent should extend 3 ft higher than point of emergence thru roof, and at least 2 ft higher than any object within radius of 10 feet. See Fig. 4.
- 10. A type-B1 gas vent shall terminate above the roof surface with a listed cap or roof assembly.

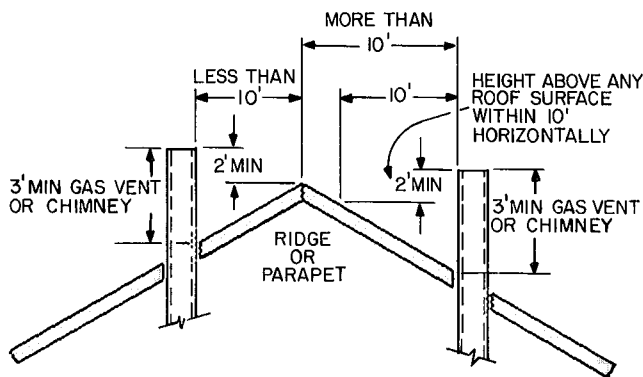

**Fig. 4 — Chimney, Gas Vent Height**

## ELECTRICAL

**IMPORTANT:** Before proceeding with the electrical connections, make certain that voltage, frequency, and phase correspond to that specified on the furnace rating plate. Also, check to be sure that the service provided by the utility is sufficient to handle the additional load imposed by this equipment. Refer to the unit rating plate for equipment electrical requirements.

- The specific furnace installation instructions contain wiring diagrams that show the proper field high- and low-voltage wiring. Make all connections in accordance with the National Electrical Code and any local codes or ordinances that might apply.

- **WARNING:** The cabinet must have an uninterrupted or unbroken ground according to National Electrical Code, ANSI/NFPA 70-1981, ANSI C1-1981, or local codes to minimize personal injury if an electrical fault should occur. This may consist of electrical wire or conduit approved for electrical ground when installed in accordance with existing electrical codes. Do not use gas piping as an electrical ground.

**CAUTION:** If manual disconnect switch is to be mounted on the furnace, select a location where drill or fastener will not contact electrical or gas components.

**NOTE:** Use only copper wire between disconnect switch and furnace. If aluminum wire is used between service panel and disconnect switch, adhere to the following recommendations.

When making aluminum conductor connections to copper conductors or terminals, use only connectors that are UL approved (marked Al/Cu with the UL symbol) for the application and wire size. Do not reduce wire size to fit connector by cutting off strands. Use properly sized connectors.

After insulation has been stripped from the aluminum conductor, coat the conductor end with corrosion inhibitor (Burdny Pentrox A or equivalent), and wire-brush the aluminum surface thru the inhibitor.

**CAUTION:** Do not wire-brush connectors and lugs. The plating will be broken.

After cleaning, recoat the aluminum conductor with inhibitor, and make connection, then coat entire connection. When it is suspected that the connection will be exposed to moisture, it is very important to cover the entire connection completely to prevent an electrochemical action that will cause the connection to fail very quickly.

If aluminum conductors are to be used, the wire size selected must have a current capacity not less than that of the copper wire specified, and must not create a voltage drop between the service panel and the furnace in excess of 2% of the unit rated voltage.

Check all electrical connections (both factory and field) for tightness. This should also be done after the unit has reached operating temperatures, especially if aluminum conductors are used.

## START-UP, ADJUSTMENT, AND SAFETY CHECK

**Pilot** — Check to be sure that all connections have been properly made, then proceed as follows:

Light the pilot, using the procedure outlined on the Lighting Instruction Plate attached to the fur-

nace. However, when lighting the pilot for the first time, perform the following additional steps:

- 1. If supply line was not purged before connecting furnace, it will be full of air. It is recommended that the ground joint union be cracked, and supply line be allowed to purge until odor of gas is detected. Never purge gas lines into combustion chamber. Immediately upon detection of gas odor, retighten the union. Allow 5 minutes to elapse, then light pilot in accordance with instructions on furnace.
2. Pilot flame should be soft blue in color.
  - a. For natural gas controls, flame should be long enough to provide good impingement on element of pilot. Flame should extend above the carryover ports of the burner.
  - b. For complete shutoff gas controls, flame should surround tip of thermocouple element of pilot and extend downward to include 3/8 to 1/2-in. of thermocouple. Flame must never come in contact with any other part of thermocouple or its lead wire. Flame lies under carryover port of burner and merges with carryover flame.
3. Pilot adjusting screw is located on main gas valve or pilot shutoff valve.
  - a. Remove capscrew; turn pilot gas full on and turn adjusting screw until desired appearance is obtained.
  - b. Replace capscrew.
4. For natural gas controls, check the pilot operation as follows: Attach a low-voltage test light to electrical leads of gas valve. With thermostat set above room temperature, shut off gas supply to burners and pilot with main manual shutoff valve. If test light goes out within 45 seconds, pilot is functioning properly. If light does not go out within 60 seconds, replace pilot.
5. The 100% safety control can be easily checked by unscrewing pilot thermocouple lead from gas valve. Pilot and main burner gas should shut off — no gas should flow thru valve. After valve is checked and found to operate satisfactorily, reconnect thermocouple to gas valve to finger-tight position. Then tighten 1/4 turn with a wrench. Relight pilot, following lighting instructions on furnace.

**Burners** — Light main burners using procedure contained on Lighting Instruction Plate attached to furnace.

**Gas Input** — Determine the gas input as follows:  
NATURAL GAS

1. Turn off all other gas appliances and pilots.
2. Measure time (in seconds) for gas meter test dial to complete one revolution.

3. Refer to Table 2 for cu ft of gas per hour.

→ **Table 2 — Gas Rate (Cubic Feet Per Hour)**

SECONDS FOR ONE REVOLUTION	SIZE OF TEST DIAL			SECONDS FOR ONE REVOLUTION	SIZE OF TEST DIAL		
	1 cu ft	2 cu ft	5 cu ft		1 cu ft	2 cu ft	5 cu ft
10	360	720	1800	50	72	144	360
11	327	655	1636	51	71	141	355
12	300	600	1500	52	69	138	346
13	277	555	1385	53	68	136	340
14	257	514	1286	54	67	133	333
15	240	480	1200	55	65	131	327
16	225	450	1125	56	64	129	321
17	212	424	1059	57	63	126	316
18	200	400	1000	58	62	124	310
19	189	379	947	59	61	122	305
20	180	360	900	60	60	120	300
21	171	343	857	62	58	116	290
22	164	327	818	64	56	112	281
23	157	313	783	66	54	109	273
24	150	300	750	68	53	106	265
25	144	288	720	70	51	103	257
26	138	277	692	72	50	100	250
27	133	267	667	74	48	97	243
28	129	257	643	76	47	95	237
29	124	248	621	78	46	92	231
30	120	240	600	80	45	90	225
31	116	232	581	82	44	88	220
32	113	225	563	84	43	86	214
33	109	218	545	86	42	84	209
34	106	212	529	88	41	82	205
35	103	206	514	90	40	80	200
36	100	200	500	92	39	78	196
37	97	195	486	94	38	76	192
38	95	189	474	96	38	75	188
39	92	185	462	98	37	74	184
40	90	180	450	100	36	72	180
41	88	176	439	102	35	71	178
42	86	172	429	104	35	69	173
43	84	167	419	106	34	68	170
44	82	164	409	108	33	67	167
45	80	160	400	110	33	65	164
46	78	157	391	112	32	64	161
47	76	153	383	116	31	62	155
48	75	150	375	120	30	60	150
49	73	147	367				

4. Multiply cu ft per hour times heating value of gas (Btu/cu ft). Obtain heating value of gas from local gas utility.

Example:

Btu/cu ft x cu ft = Btuh heating input

Time for one revolution of 2 cu ft dial = 72 seconds

Heat value of gas = 1070 Btuh/cu ft

100 x 1070 = 107,000 Btuh input

- 5. Measured gas input should not exceed gas input shown on unit rating plate.
6. To adjust input rate, remove cap that conceals regulator adjustment. Turn adjusting screw counterclockwise (out) to decrease input. When adjusting, DO NOT change manifold pressure more than 0.3 in. wg. Any major adjustment should be made by changing main burner orifices.

**LP (PROPANE) GAS** — These units are equipped with pressure regulators. Burner orifices are sized to

give rated input at a manifold pressure of 10.5 in. wg. Check manifold pressure and, if necessary, adjust pressure.

**HIGH ALTITUDE** — Ratings are approved for altitudes to 2000 ft for all gases. Ratings for altitudes over 2000 ft are 4% less for each 1000 ft above sea level.

**Adjust Main Burner Flame** — The main burner flame should be clear blue, almost transparent, with a well-defined inner cone. If there is too much primary air, the flame will be well defined, but with a tendency to float or lift off the burner ports. See Fig. 5.

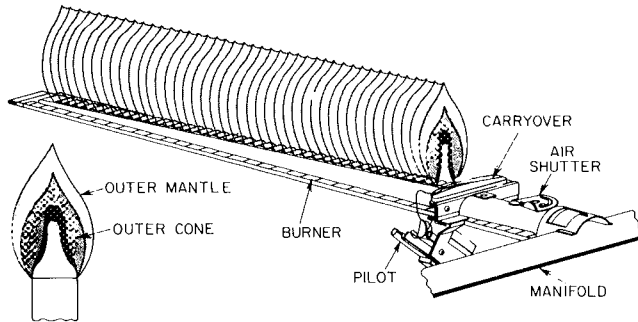

**Fig. 5 — Burner Flame**

1. Allow unit to operate 5 minutes.
2. When burners are equipped with primary air adjustment, adjust each burner by closing air adjustment device until slight yellow tip appears on flame; then open, just enough to clear yellow from flame.

**Temperature Rise** — The unit is to be adjusted within the temperature rise range specified on the rating plate. Determine the air temperature rise as follows:

1. Place duct thermometers in return and supply ducts as near furnace as possible. Be sure thermometers do not "see" heat element so that radiant heat will not affect thermometer readings. This is particularly important with straight-run ducts.
2. When thermometers stabilize, subtract return air temperature from supply air temperature to determine air temperature rise.
3. Adjust air temperature rise by adjusting blower speed. Increase blower speed to reduce temperature rise. Decrease blower speed to raise temperature rise.

**Limit Control Safety Check** — This control shuts off the gas and energizes the blower motor if the furnace becomes overheated.

The recommended method of checking the limit control is to gradually block off the return air after the furnace has been operating for a period of at least 5 minutes. As soon as the limit has proven safe, the return air opening should be unblocked to permit normal air circulation. By using this method to check the limit control, it can be established that the limit is functioning properly and will be fail-safe if there is a motor failure.

### **FURNACE LOCATION WITH RESPECT TO COOLING EQUIPMENT**

The cooling coil must be installed parallel with or on the downstream side of the furnace to avoid condensation in the heating element. When installed parallel with a furnace, dampers or other means used to control the flow of air must prevent chilled air from entering the unit. If the dampers are manually operated, they must be equipped with means to prevent operation of either unit unless the damper is in the full-heat or full-cool position.

### **SPECIAL LOCATIONS**

A gas-fired furnace installed in a residential garage should be installed so the burners and ignition source are located not less than 18 in. above the floor and the furnace is located or protected to avoid physical damage by vehicles.

When furnaces are installed in public garages, airplane hangars, or other buildings having hazardous atmospheres, the unit should be installed in accordance with the recommended good practice requirements of the National Board of Fire Underwriters.

Manufacturer reserves the right to discontinue, or change at any time, specifications or designs without notice and without incurring obligations.

<b>Book</b>	<b>1</b>
<b>Tab</b>	<b>6a</b>

Form 58-9XA Supersedes 58-7XA

Printed in U S A

3-82

PC 101

Catalog No 515-802