

MODEL
SVL-2



SVL-2

SPEAKER SELECTION/VOLUME CONTROL SYSTEM



INSTALLATION & OPERATION GUIDE

SVL-2

Speaker Selection/
Volume Control
System

TABLE OF CONTENTS

Introduction	1
Features and Benefits	2
Installation Considerations	4
Installation	8
Operation	10
Specifications	14

Introduction

The SVL-2 is a combination speaker selector and volume controller. It allows you to connect two pairs of speakers to your stereo receiver or amplifier and adjust the volume of each pair independently. Additionally, you can choose to listen to either pair of speakers, or both pairs simultaneously. You don't have to worry about overloading your amplifier. The SVL-2 has a protection circuit that keeps your amplifier running safely, even with both pairs of speakers playing.

A perfect application for the SVL-2 is individually controlling speaker "ON/OFF" and volume adjustment for two pairs of speakers: one pair in the room with the main stereo system and another pair at a remote location. The SVL-2 adjusts the volume of the speakers connected to it by attenuating the amplifier signal. Niles volume controls use autoformers instead of L-pads for the volume controlling element. This assures minimal internal power dissipation with virtually no power wasted as heat.



Features and Benefits

The SVL-2 offers a number of improvements over other speaker selector/volume controllers:

- The SVL-2 uses 12 position volume controls which are superior to 10 position designs. You get a broader range of adjustment—there are 10 steps of attenuation instead of 8. Steps 11-6 attenuate -3 dB per step; steps 5-2 are 6 dB per step. Step 12 is "full-on" and step 1 is "full-off".
- Greater dynamic range—you get 42 dB of total attenuation instead of the usual 20 or 30 dB.
- POP-FREE switching between all steps.
- Pre-printed Room Labels are included for easy identification of speaker ON/OFF buttons.
- Isolated right and left channel ground returns make the SVL-2 compatible with all types of amplifiers.
- Self-cleaning, silver-plated switch contacts assure many years of trouble free use.
- Printed circuit board design assures high reliability.

TECH SUPPORT HOTLINE

If you have questions regarding the operation of the Niles SVL-2, contact your local Niles dealer or Niles Customer Service at 1-800-289-4434.

- Spring-loaded push terminal connectors accommodate up to 14 gauge wire or "pins", making the SVL-2 compatible with most "high-definition" speaker cables.
- 100% tested, electronically and acoustically, for frequency response, distortion and power handling.
- Only 8 1/2" wide. Match the width of 17" components by combining with another Niles 1/2 width product.
- May be used with 4, 6 or 8-ohm speaker systems.
- Ideal for both home and commercial sound installations.
- Only a wire stripper is required for installation.
- Power handling: 100 watts/channel continuous music power.
- Frequency response: 20 Hz to 20 kHz +/-1.2 dB.
- Ten year parts and labor warranty.
- Proudly made in the USA.

Installation Considerations

SVL-2 Power Handling

The SVL-2 is designed for use with a receiver or amplifier having a maximum power output of 100 watts per channel at 8 ohms. Damage caused by the use of a higher-power receiver or amplifier will void the warranty. Consult your Niles dealer, or receiver/amplifier manufacturer, if you are uncertain about the power rating of your receiver or amplifier.

IMPORTANT: DO NOT USE THE SVL-2 WITH AMPS OR RECEIVERS RATED AT MORE THAN 100 WATTS PER CHANNEL RMS AT 8 OHMS.

Amplifier Impedance Load

As more pairs of speakers are parallel connected to a receiver or amplifier, the overall system impedance becomes lower. For example, if two pairs of 8-ohm speakers are connected in parallel, the impedance will be 4 ohms, two pairs of 4-ohm speakers in parallel become 2 ohms, and so on.

Most receivers or amplifiers are not rated for use below a 4 ohm load. Most manufacturers do not recommend connecting two pairs of 4-ohm speakers without using some form of impedance correction.

TOOLS REQUIRED

- Wire Stripper

IMPORTANT

DO NOT use the SVL-2 with amps or receivers rated at more than 100 watts per channel RMS at 8 ohms.

The SVL-2 includes impedance correction circuitry which protects your receiver or amplifier from low impedance loads. The circuitry assures that your receiver or amplifier will see a safe operating load, even when two pairs of 4-ohm speakers are playing at the same time.

"TECH TIP"

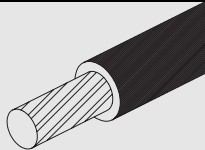

Wire size is expressed by its AWG (American Wire Gauge) number. The lower the AWG number, the larger the wire, i.e., 12 AWG wire is physically larger than 14 AWG.

Type of Speaker Wire

For most applications, we recommend you use 16 or 18 gauge stranded copper speaker wire for the SVL-2 connections. For wiring runs longer than 80 feet, 14 gauge wire is recommended. Using speaker wire larger than 14 gauge for the SVL-2 connections is not recommended—the wire may not fit into the connectors. Never use solid-core, aluminum, or "Romex" type wire with the SVL-2. When running speaker wires inside walls, most states and municipalities in the U.S. specify that you must use a special type of speaker wire. Usually, the requirement is that the wire has a specific "CL" fire rating, such as "CL-2" or "CL-3". Consult your Niles dealer, building contractor, or local building and inspection department if unsure about which type of wire is best for your application.

Avoiding Interference

Speaker wires can act as an antenna for electrical noise. Locating speaker wires too close to a light dimmer or switch may cause a "buzzing" or "popping" sound to be heard through the speakers. If you must locate the SVL-2 wiring

near electrical devices, route the speaker wires several feet away from the electrical wiring.

Using the SVL-2 with Tube-Type Amplifiers

Virtually all tube amplifiers must have a load connected at all times. If the amplifier to be connected to the SVL-2 is a tube amplifier, be sure to always have at least one pair of speakers switched on at all times. An alternative is to permanently connect a 150 ohm, 5 watt resistor across the tube amplifier's output in parallel with the SVL-2. See (Figure 1) for hookup diagram.

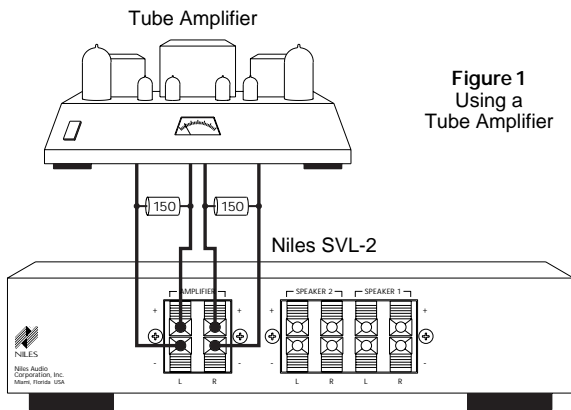

S P E A K E R S E L E C T I O N / V O L U M E C O N T R O L S Y S T E M

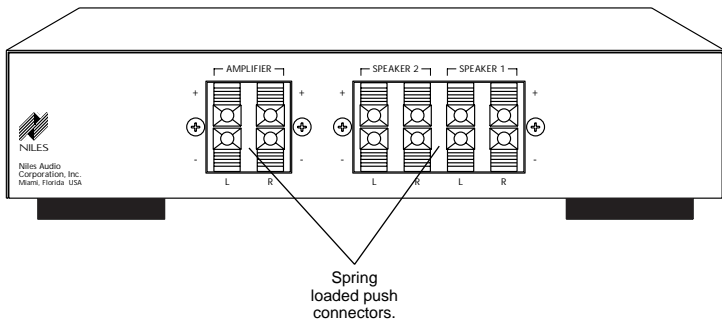
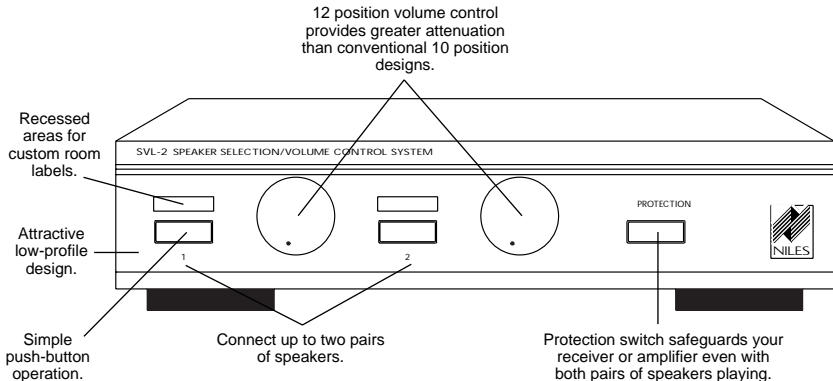

Installation

1. Select a convenient location for the SVL-2.
2. Run all the necessary wiring to the SVL-2. Label the wires for future reference. See (Figure 2).

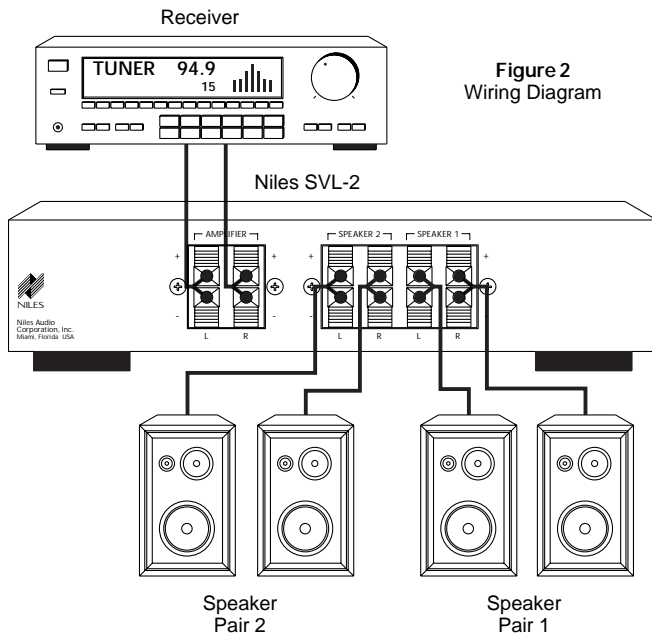

3. Make the connections to the SVL-2. Strip 3/8" of insulation from the end of each wire. Tightly twist the end of each wire until there are no frayed ends. Insert each wire into the appropriate hole on the spring-loaded connector terminals. Be certain that proper phasing is observed—connect the positive terminals on the SVL-2 to the positive terminals on the amplifier and speakers and the negative terminals on the SVL-2 to the negative terminals on the amplifier and speakers. See (Figure 3).

4. Locate the pre-printed Room Labels. Affix the appropriate label to the recessed area over each ON/OFF selector button.

Figure 3
Removing the
Connectors

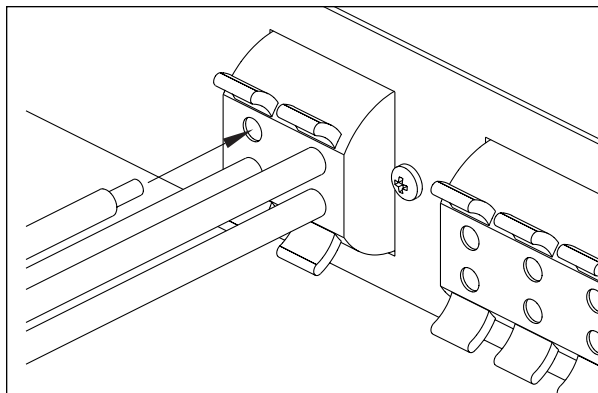

Operation

There are two ways to use the SVL-2. You may play and adjust the volume of either pair of speakers independently, or both pairs simultaneously.

If you intend to play both pairs simultaneously, and either pair is less than 8 ohms, you will need to become familiar with the operation of the SVL-2's PROTECTION button.

Playing One Pair of Speakers At a Time

1. Make sure the amplifier or receiver power is OFF and set the volume to minimum.
2. Set the SVL-2 volume control for the speaker pair you wish to play to maximum (fully clockwise).
3. Locate the ON/OFF button on the SVL-2 which corresponds to the speaker pair you wish to play. Set it to the ON position.
4. Turn on the amplifier or receiver and select as source, such as the tuner or CD player.
5. Slowly turn up the amplifier or receiver volume and set it to a comfortable (not maximum) listening level. Be careful not to overdrive or "clip" your amplifier. If the sound becomes muddy or distorted, you have reached the limit of your amplifier's volume capability and should quickly reduce the volume to avoid damaging your speakers.

"TECH TIP"

If your amplifier or receiver has "A" and "B" speaker-pair outputs, connect the SVL-2 to the "A" outputs.

Do not connect anything to "B". This will prevent the amplifier or receiver from driving an unusually low impedance load.

6. Using the appropriate volume control on the front of the SVL-2, adjust the volume of the speakers to the desired listening level.

7. You can turn off the speakers by turning the appropriate volume control on the SVL-2 fully counter-clockwise, or by pressing the ON/OFF button.

Playing Two Pairs of Speakers Simultaneously

1. Make sure the amplifier or receiver power is OFF and set the volume to minimum.

2. On the right side of the SVL-2's front panel is a button labeled PROTECTION. This button activates the SVL-2's impedance correction circuitry. The circuitry assures that your receiver or amplifier will see a safe operating load when playing two pairs of speaker simultaneously. Since most receivers and amplifiers are not rated for use below a 4 ohm load, you will need to activate the PROTECTION button whenever the overall system impedance might fall below 4 ohms. Use the following chart as a guide for setting the PROTECTION button.

When playing the following speakers:	The Protection button should be:
1 or 2 pair of 8-ohm speakers	OFF
1 pair of 4-ohm speakers	OFF
2 or more pairs of 4-ohm speakers	ON
Any combination of 4 and 8 ohm speakers	ON

Set the PROTECTION button to the correct position using the chart shown above.

3. Set both SVL-2 volume controls to maximum.
4. Locate the ON/OFF buttons on the SVL-2. Set both to the ON position.
5. Turn on the amplifier or receiver and select as source, such as the tuner or CD player.
6. Slowly turn up the amplifier or receiver volume and set it to a comfortable (not maximum) listening level. Be careful not to overdrive or "clip" your amplifier. If the sound becomes muddy or distorted, you have reached the limit of your amplifier's volume capability and should quickly reduce the volume to avoid damaging your speakers.
7. Using the appropriate volume controls on the front of the SVL-2, adjust the volume of the speakers to the desired listening level.
8. You can turn off the speakers by turning the appropriate volume controls on the SVL-2 fully counter-clockwise, or by pressing the appropriate ON/OFF buttons.

"TECH TIP"

You will need to activate the SVL-2's PROTECTION button whenever the overall system impedance might fall below 4 ohms.

Balancing Speaker Volume

The volume control on your receiver or amplifier serves as the "master" volume for all speaker pairs connected.

The volume level of the speakers may vary from room to room. This is caused by several factors. Two lesser factors are the size of the speaker and its efficiency. The largest factor is the physical size of the room.

The SVL-2's volume controls allow you to adjust the volume of each speaker pair individually. You can leave the amplifier or receiver volume set at one position and use the SVL-2 volume controls exclusively.

SPECIFICATIONS

Audio Power Handling

100 watts/channel continuous music power

Frequency Response

+/- 1.2 dB from 20 Hz to 20 kHz

Mounting

Table-top component

Wiring Requirements

Individual runs of 2-conductor speaker wire. Connectors accommodate wire sizes 14-22 gauge (16 gauge recommended)

Overall Dimensions

8-1/2" wide x 2" high x 7-1/4" deep

Weight

3 lb.



Niles Audio
Corporation

www.nilesaudio.com

12331 S.W. 130 Street
Miami, Florida 33186
Tel: (305) 238-4373
Fax: (305) 238-0185

© 1999 Niles Audio Corporation. All rights reserved. Because Niles constantly strives to improve the quality of its products, Niles reserves the right to change product specifications without notice. Niles and the Niles logo are registered trademarks of Niles Audio Corporation. Printed in USA 4/96 DS00094A