

## BASIC OPERATION INSTRUCTIONS

---

# Dynamic Controller

ACN# 088 609 661

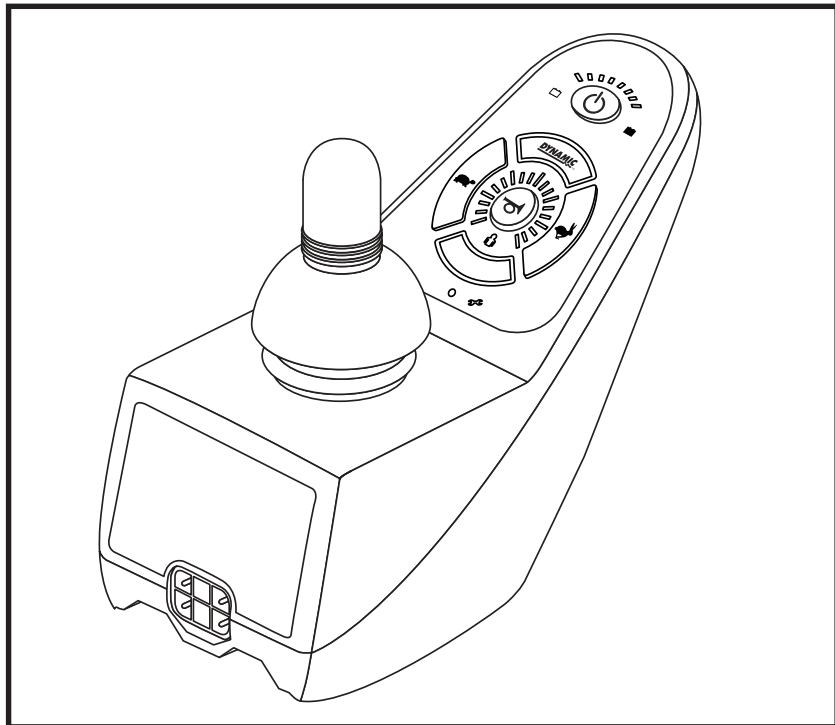

**Pride**<sup>®</sup>  
Mobility Products Corp.

## SAFETY GUIDELINES



**WARNING!** An authorized Pride Provider or a qualified technician must perform the initial setup of this product and must perform all of the instructions in this manual.

The symbols below are used throughout this owner's manual and on the controller to identify warnings and important information. It is very important for you to read them and understand them completely.



**WARNING!** Indicates a potentially hazardous condition/situation. Failure to follow designated procedures can cause either personal injury, component damage, or malfunction. On the product, this icon is represented as a black symbol on a yellow triangle with a black border.



**MANDATORY!** These actions should be performed as specified. Failure to perform mandatory actions can cause personal injury and/or equipment damage. On the product, this icon is represented as a white symbol on a blue dot with a white border.



**PROHIBITED!** These actions are prohibited. These actions should not be performed at any time or in any circumstances. Performing a prohibited action can cause personal injury and/or equipment damage. On the product, this icon is represented as a black symbol with a red circle and a red slash.

***NOTE: These instructions are compiled from the latest specifications and product information available at the time of publication. We reserve the right to make changes as they become necessary. Any changes to our products may cause slight variations between the illustrations and explanations in this manual and the product you have purchased. The latest/current version of this manual is available on our website.***

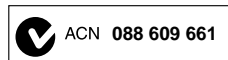

Copyright © 2008  
Pride Mobility Products Corporation  
INFMANU3676/Rev B/May 2008

Dynamic Controller

[www.pridemobility.com](http://www.pridemobility.com)

# TABLE OF CONTENTS

LABEL INFORMATION .....	4
INTRODUCTION .....	5
DYNAMIC CONTROLLER .....	7
PRECAUTIONARY GUIDELINES .....	7
OPERATING THE DYNAMIC CONTROLLER .....	11
CONTROLLER CONNECTOR .....	16
OFF-BOARD CHARGER/PROGRAMMING SOCKET .....	16
LOCK MODE .....	16
ACTUATOR ADJUSTMENT .....	17
SLEEP MODE (IF ENABLED) .....	18
OUT OF NEUTRAL AT POWER UP (OONAPU) .....	18
ERROR CODES .....	18
CARE AND MAINTENANCE .....	19
WARRANTY .....	19

# LABEL INFORMATION

## PRODUCT SAFETY SYMBOLS

The symbols below are used on the controller to identify warnings, mandatory actions, and prohibited actions. It is very important for you to read and understand them completely.



Read and follow the information in the owner's manual.



Avoid exposure to rain, snow, ice, salt, or standing water whenever possible. Maintain and store in a clean and dry condition.



EMI-RFI - This product has been tested and passed at an immunity level of 20 V/m.



Disposal and recycling - Contact your authorized Pride Provider for information on proper disposal and recycling of your Pride product and its packaging.

## INTRODUCTION

WELCOME to Pride Mobility Products Corporation (Pride). The product you have purchased combines state-of-the-art components with **safety**, comfort, and styling in mind. We are confident that the design features will provide you with the conveniences you expect during your daily activities. Understanding how to **safely** operate and care for this product should bring you years of trouble free operations and service.

**Read and follow** all instructions, warnings, and notes in this manual before attempting to operate your product for the first time. You must also read all instructions, warnings, and notes contained in any supplemental instructional booklets for the controller, front riggings, and/or seating system that accompanied your power chair before initial operation. Your **safety** depends upon you, as well as your provider, caretaker, or healthcare professional in using good judgement.

This manual is to be used in addition to the power base owner's manual that came with your power chair. If there is any information in this manual which you do not understand, or if you require additional assistance for setup or operation, please contact your authorized Pride Provider. **Failure to follow the instructions, warnings, and notes in this manual and those located on your Pride product can result in personal injury and/or product damage and will void Pride's product warranty.**

## PURCHASER'S AGREEMENT

By accepting delivery of this product, you promise that you will not change, alter, or modify this product or remove or render inoperable or unsafe any guards, shields, or other safety features of this product; fail, refuse, or neglect to install any retrofit kits from time to time provided by Pride to enhance or preserve the safe use of this product.

## INFORMATION EXCHANGE

We want to hear your questions, comments, and suggestions about this manual. We would also like to hear about the safety and reliability of your new Pride product, and about the service you received from your authorized Pride Provider. Please notify us of any change of address, so we can keep you apprised of important information about safety, new products, and new options that can increase your ability to use and enjoy your Pride product.

*NOTE: If you ever lose or misplace your product registration card or your copy of this manual, contact us and we will be glad to send you a new one immediately.*

**My authorized Pride Provider Is:**

Name: \_\_\_\_\_

Address: \_\_\_\_\_

Phone Number: \_\_\_\_\_

Purchase Date: \_\_\_\_\_

## DYNAMIC CONTROLLER

The Dynamic controller is a modular electronic controller system that allows you to operate your power chair. It is designed to allow the user to have complete control over chair movement and speed.

The controller is available in both 50-amp and 60-amp configurations, and has been pre-programmed to meet a typical user's needs. The program is set using either a personal computer with software provided by the controller manufacturer or with a hand-held programmer, also provided by the controller manufacturer.



**WARNING!** The controller program can affect speed, acceleration, deceleration, dynamic stability, and braking. If it is programmed incorrectly or outside of the safe limits as determined by your healthcare professional, it can create a dangerous situation. Only the power chair manufacturer, an authorized representative of the manufacturer, or a trained service technician should program the controller.

## PRECAUTIONARY GUIDELINES

Before operating the Dynamic controller, please read the following. These guidelines are provided for your benefit and will aid you in the safe operation of the controller system.

- Turn off the power to the controller when transferring to or from your power chair.
- Follow all of the procedures and heed the warnings as explained in your power chair owner's manual.

## Electromagnetic and Radio Frequency Interference (EMI/RFI)



WARNING! Laboratory tests have shown that electromagnetic and radio frequency waves can have an adverse affect on the performance of electrically-powered mobility vehicles.

Electromagnetic and Radio Frequency Interference can come from sources such as cellular phones, mobile two-way radios (such as walkie-talkies), radio stations, TV stations, amateur radio (HAM) transmitters, wireless computer links, microwave signals, paging transmitters, and medium-range mobile transceivers used by emergency vehicles. In some cases, these waves can cause unintended movement or damage to the control system. Every electrically-powered mobility vehicle has an immunity (or resistance) to EMI. The higher the immunity level, the greater the protection against EMI. This product has been tested and has passed at an immunity level of 20 V/m.



WARNING! Be aware that cell phones, two-way radios, laptops, and other types of radio transmitters may cause unintended movement of your electrically-powered mobility vehicle due to EMI. Exercise caution when using any of these items while operating your mobility vehicle and avoid coming into close proximity of radio and TV stations.



WARNING! The addition of accessories or components to the electrically-powered mobility vehicle can increase the susceptibility of the vehicle to EMI. Do not modify your power chair in any way not authorized by Pride.

WARNING! The electrically-powered mobility vehicle itself can disturb the performance of other electrical devices located nearby, such as alarm systems.

***NOTE: For further information on EMI/RFI, go to the Resource Center on [www.pridemobility.com](http://www.pridemobility.com). If unintended motion or brake release occurs, turn your controller off as soon as it is safe to do so. Contact Pride or your authorized Pride Provider to report the incident.***



## Dynamic Controller Features

Figure 1 provides information on the Dynamic controller components and connections. Use this diagram to familiarize yourself with the function and location of each component before using the Dynamic controller.

The following functions are available with the Dynamic controller:

- **Joystick Control**  
The joystick is used to control the direction and speed of the power chair.
- **Speed Adjustment**  
The user can increase or decrease the maximum speed of the power chair.
- **Actuator Adjustment**  
The user can control positioning of power seat actuators with the Dynamic controller.
- **Sleep Mode**  
This feature is designed to preserve battery charge and can be disabled through programming.
- **Out of Neutral at Power Up (OONAPU)**  
A safety feature designed to prevent the power chair from overheating and causing damage to the motors or controller.

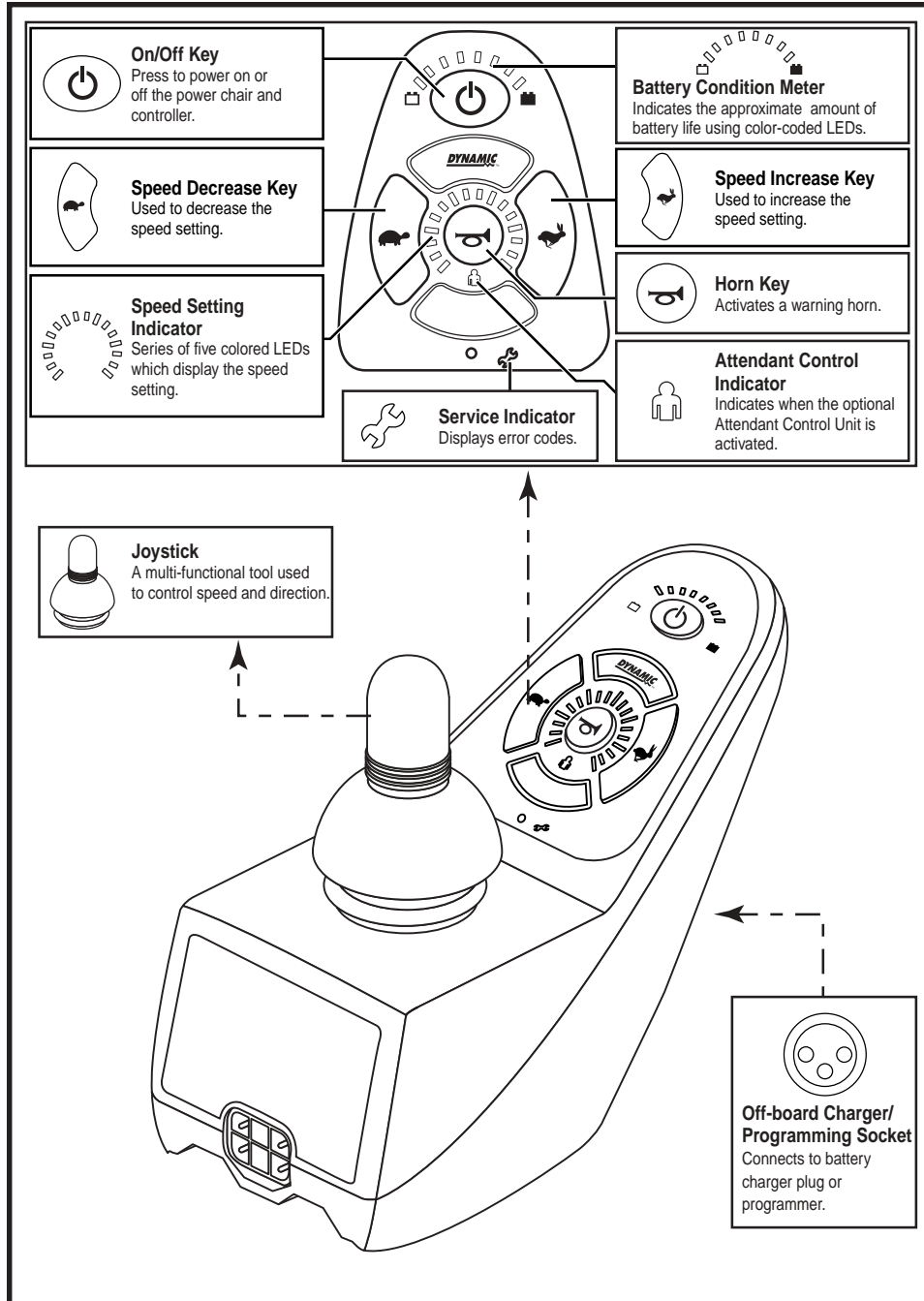

**Figure 1. Dynamic Controller Components and Connections**

## OPERATING THE DYNAMIC CONTROLLER

The Dynamic controller is used to operate your power chair and all of its components.

The Dynamic controller consists of (see figure 2):

1. joystick
2. keypad
3. off-board charger/programming socket
4. controller connector
5. power module

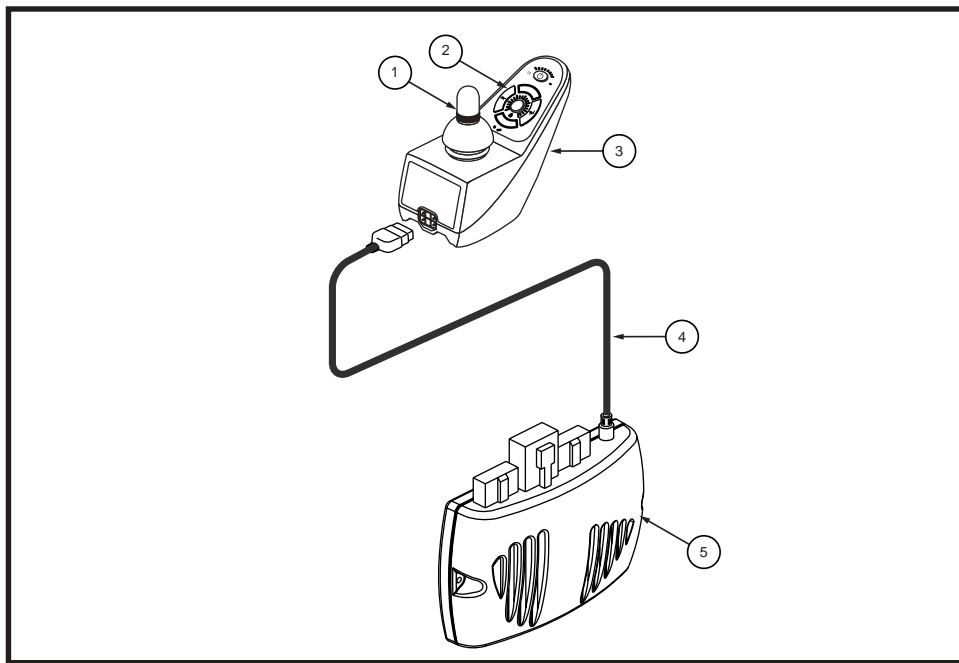

**Figure 2. Dynamic Controller**

### Joystick Control

The joystick controls the direction and speed of your power chair. When you move the joystick from the neutral (center) position, the electromagnetic brakes release and allow your power chair to move. The farther you push the joystick from its neutral position, the faster your power chair moves. When you release the joystick and allow it to return to the neutral position, you engage the electromagnetic brakes. This causes your power chair to decelerate and come to a complete stop.

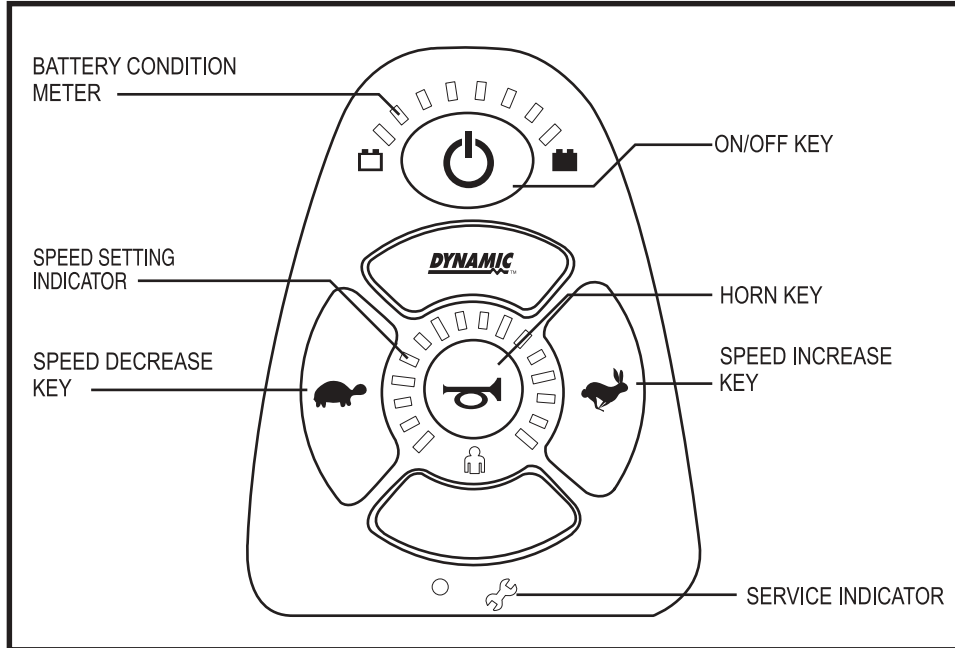

Figure 3. Dynamic Controller 4-key Keypad

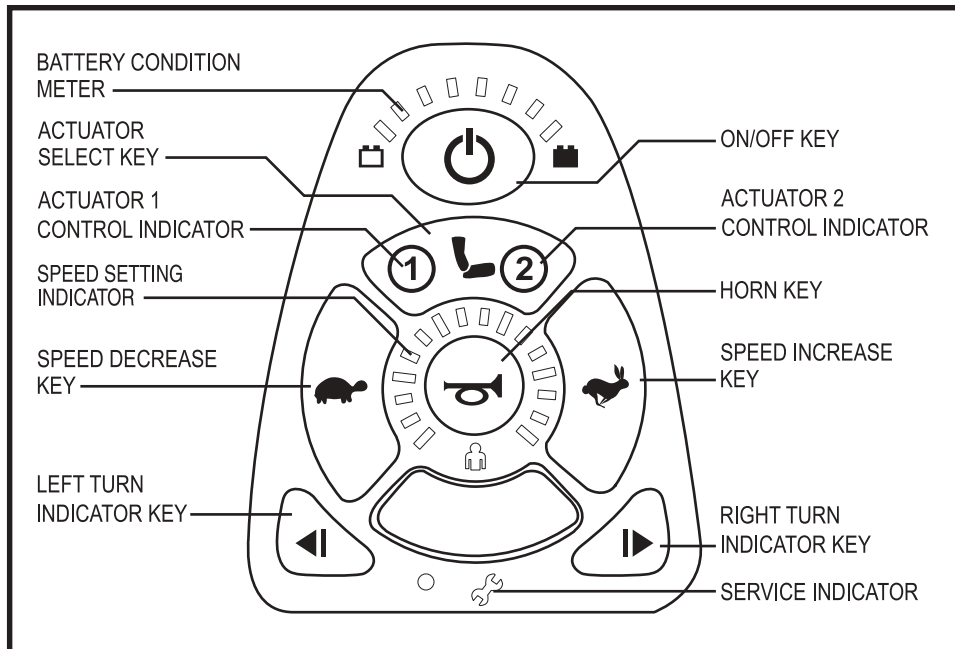

Figure 4. Dynamic Controller 7-key Keypad

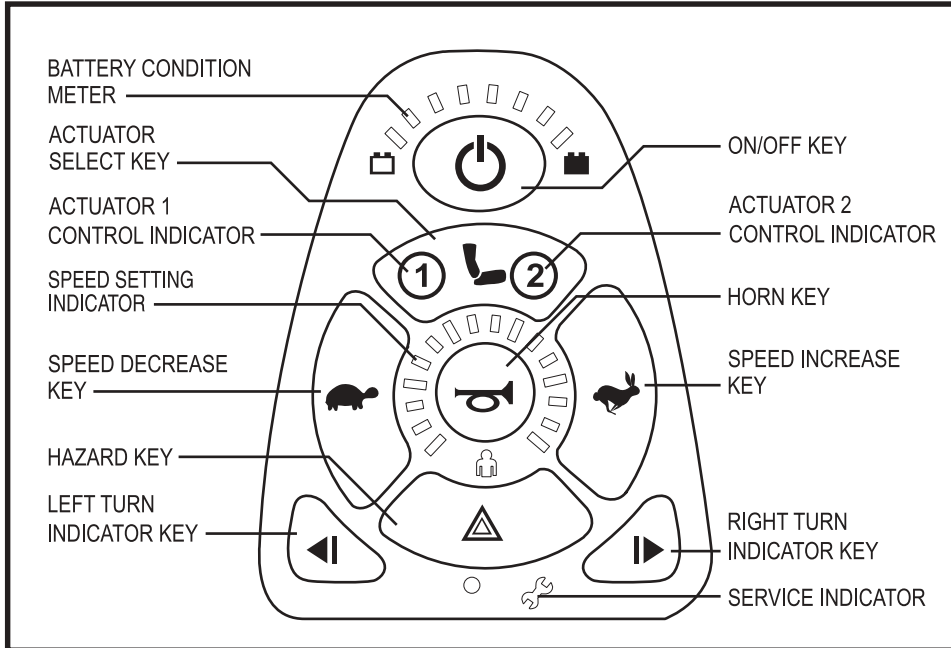

Figure 5. Dynamic Controller 8-key Keypad

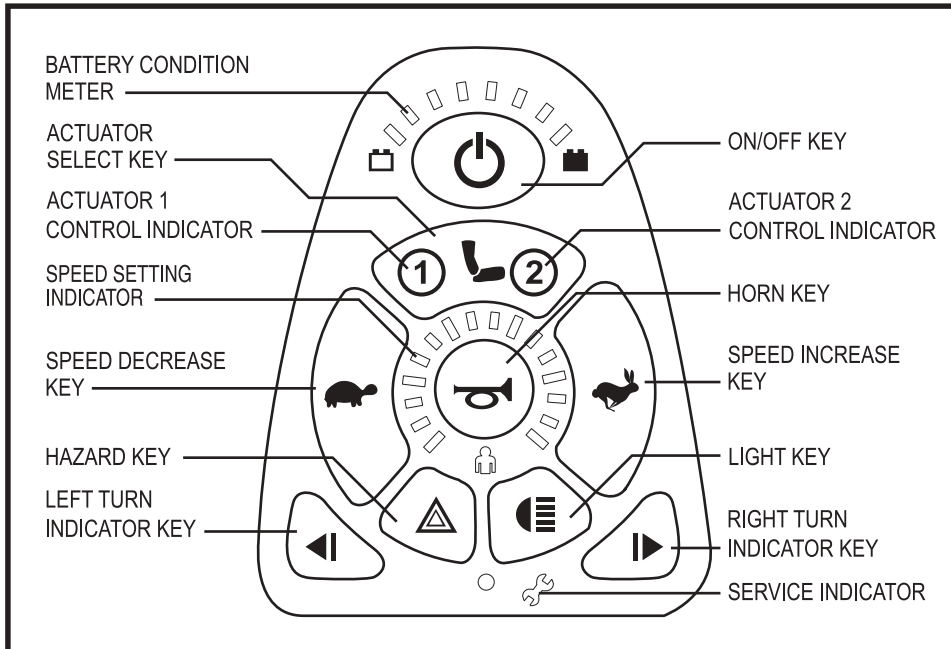

Figure 6. Dynamic Controller 9-key Keypad

### Keypad

The keypad is located directly in front of the joystick. It contains keys that you will use to control your power chair. See figure 2.

### On/Off Key

The on/off key turns the system on and off.



WARNING! Unless faced with an emergency situation, do not use the on/off key to stop the chair. This will cause the power chair to stop abruptly.

WARNING! Always turn the power off when you are stationary to prevent unexpected movement.

***NOTE: If the joystick is not in the neutral (center) position when you turn on the power, you may cause a fault in the system. See “Out Of Neutral At Power Up (OONAPU).”***

### Horn Key

The horn key activates a warning horn.

### Battery Condition Meter

The battery condition meter consists of eight lights arranged in an arc over the on/off key. As the battery voltage drops, the number of lights reduces from right to left. When the battery capacity drops to 10% or below, the left red LED will flash.

- **Left Red LED Flashing:** The battery charge is low; charge the batteries as soon as possible.
- **Right-to-Left Ripple of LEDs:** The controller is in lock mode; unlock the controller.
- **Left-to-Right Ripple of LEDs Alternating with Steady Display:** The controller is in programming, inhibit, or charging mode. When the joystick is moved, the speed gauge will also flash.

**Speed Keys**

There are two keys that control the speed. Press the speed increase key to increase the speed. Press the speed decrease key to decrease the speed. The speed setting is displayed on the speed setting indicator. If your power chair was programmed with a drive profile, contact your authorized Pride Provider for more information.

***NOTE:** We recommend that the first few times you operate your power chair, you set the speed to the slowest setting until you become familiar with your new power chair.*

**Speed Setting Indicator**

The speed setting indicator indicates the current speed of your power chair. The speed setting indicator consists of 16 lights arranged clockwise around the horn key. As the speed of the power chair increases, the number of lights increases. There are five larger LEDs which represent 0%, 20%, 40%, 60%, 80%, and 100% of the power chair's maximum speed. Press the speed decrease key or speed increase key once to adjust the speed in the five larger increments. Press and hold the the speed decrease key or speed increase key to adjust the speed in individual increments.

***NOTE:** When the bottom, left-most green LED is flashing, it indicates that the controller is in speed limit mode.*

**Service Indicator**

The service indicator displays Dynamic controller error codes. Refer to "Error Codes."

**Attendant Control Indicator (For Optional Equipment)**

The attendant control indicator is on when the optional Attendant Control Unit is activated.

**Actuator Select Key with Lights (For Optional Equipment)**

If your power chair is equipped with power accessories such as a power seat or power elevating leg rests, you can operate them through the keypad. Refer to "Actuator Adjustment."

**Right/Left Turn Indicator Keys (For Optional Equipment)**

The right/left turn indicator keys toggle either the left or right turn indicators. Press once to turn on and press again to turn off. You can also turn off the selected turn indicator by pressing the opposite indicator key or the hazard key.

**Light Key (For Optional Equipment)**

The light key turns the headlights/taillights on and off independent of other indicators.

**Hazard Key (For Optional Equipment)**

The hazard key activates both turn indicators at the same time. You can only cancel this by pressing the hazard key again.

**CONTROLLER CONNECTOR**

This connects the Dynamic controller to the power module located on the power base.

**OFF-BOARD CHARGER/PROGRAMMING SOCKET**

You may use an off-board charger to charge the power chair batteries through the 3-pin socket located on the front of the Dynamic controller. If you use an off-board charger, the charger current should not exceed 8 amps. Contact your authorized Pride Provider for more information.



**WARNING!** Only chargers with Neutrik NC3MX plugs should be connected to the off-board charger/programming socket. See your authorized Pride Provider for more information.

***NOTE: The socket may also be used for reprogramming the Dynamic controller. Contact your authorized Pride Provider for more information.***

**LOCK MODE**

The Dynamic controller is equipped with a feature that enables you to “lockout” unauthorized users.

**To lock the Dynamic controller:**

1. While the power is on, press and hold the on/off key for 4 seconds. The display will turn off immediately. After 4 seconds, all LEDs will flash briefly and the horn will sound a short beep.
2. The Dynamic controller is now locked.



**To unlock the Dynamic controller:**

1. While the Dynamic controller is locked, press the on/off key to turn on the controller. All LEDs will flash briefly. The LEDs will then slowly ripple from right to left.
2. Press the horn key twice before the LED ripple has completed, approximately 10 seconds. The controller is now unlocked.

**NOTE:** *If you do not press the horn key twice before the countdown is complete, the system will beep and the Dynamic controller will turn itself off. The unlock sequence must be completed successfully before the Dynamic controller will operate again.*

**ACTUATOR ADJUSTMENT**

The Dynamic controller can control two actuators using the mode key and the joystick. The active actuator is indicated by an illuminated actuator LED. See figure 4, 5, or 6.

**To select and adjust an actuator:**

1. Press the on/off key to power on the controller.
2. Press the actuator select key once to select Actuator Adjustment Mode. Actuator 1 will be active as noted by the amber “1” indicator.
3. Push the joystick to the right or press the actuator select key again to cycle through the available actuators. The actuator indicators will display which actuator is activated. See figure 7.
4. When the desired actuator is selected, give a forward command to the joystick to raise the actuator or give a reverse command to the joystick to lower the actuator.
5. Press the actuator select key again to return to the Drive Mode.

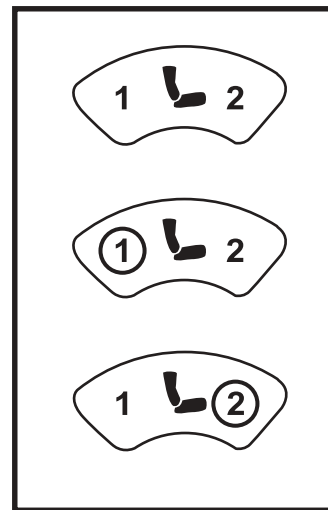

**Figure 7. Actuator Indicators (None, Actuator 1, and Actuator 2 Shown)**

**SLEEP MODE (IF ENABLED)**

The power chair controller features a sleep mode. Sleep mode is a built-in circuit that will automatically shut off the main power if the joystick is not moved in any direction for a period of time. This time factor is programmed into the controller. To restore power and continue, push any key on the keypad.

**OUT OF NEUTRAL AT POWER UP (OONAPU)**

Your power chair joystick is equipped with Out Of Neutral At Power Up (OONAPU). If you power up the system and the joystick is not in the neutral position, all of the lights in the speed setting indicator will flash rapidly for as long as the joystick is out of the neutral position. Allow the joystick to return to the neutral position and the fault will clear.

**ERROR CODES**

The service indicator will flash error codes when the Dynamic controller detects an abnormal condition in the electrical system. The service indicator will flash a number of times quickly, then pause, then flash again. The service indicator will continue to flash the error codes until the problem is fixed. The following table identifies the individual error codes. If any of these error codes persist or if you experience any other problem with your power chair, contact your authorized Pride Provider.

***NOTE: When the service indicator flashes an error, the battery condition meter LEDs will also flash an inhibit. See “Battery Condition Meter.”***

Error Code	Probable Cause	Possible Solution
1	Possible stall timeout or user error	Release the joystick.
2	Battery Fault	Check the batteries and cables. Try to charge the batteries. The batteries may need to be replaced.
3	Left Motor Fault	Check the left motor, connections, and cabling.
4	Right Motor Fault	Check the right motor, connections, and cabling.
5	Left Park Brake Fault	Check the left park brake, connections, and cabling.
6	Right Park Brake Fault	Check the right park brake, connections, and cabling.
7	Dynamic Controller Module Fault	Check the communications connections and wiring.
8	Dynamic Controller Power Module Fault	Check the communications connections and wiring.
9	Dynamic Controller Communications Fault	Check the communications connections and wiring.
10	Unknown Fault	Contact your authorized Pride Provider.
11	Incompatible Controller Fault	Contact your authorized Pride Provider.

## CARE AND MAINTENANCE

Refer to your power chair owner's manual for proper cleaning and disposal instructions.

## WARRANTY

For two (2) years from the date of purchase, Pride will repair or replace at our option to the original purchaser, free of charge, the controller or any of its components found upon examination by an authorized representative of Pride to be defective in material and/or workmanship.



**Pride Mobility Products Corporation**

182 Susquehanna Avenue  
Exeter, PA 18643-2694  
USA

**Pride Mobility Products Company**

380 Vansickle Road Unit 350  
St. Catharines, Ontario L2R 6P7  
Canada

**Pride Mobility Products Ltd.**

32 Wedgwood Road  
Bicester, Oxon OX26 4UL  
UK

**Pride Mobility Products Australia Pty. Ltd.**

21 Healey Road  
Dandenong, 3175  
Victoria, Australia

**Pride Mobility Products Italia S.r.l.**

Via del Progresso - ang. Via del Lavoro  
Loc. Prato della Corte  
00065-Fiano Romano (RM)

**Pride Mobility Products Europe B.V.**

Castricummer Werf 26  
1901 RW Castricum  
The Netherlands

[www.pridemobility.com](http://www.pridemobility.com)   [www.prideservice.com](http://www.prideservice.com)   [www.quantumrehab.com](http://www.quantumrehab.com)

\* I N F M A N U 3 6 7 6 \*