

MUSTANG SURVIVAL



OWNER'S MANUAL

INFLATABLE PFDs

MD2010

Manual Inflation Model

USCG APPROVALS:

RECREATIONAL: TYPE V WITH
TYPE III PERFORMANCE
APPROVED ONLY WHEN WORN,
SPECIAL USE DEVICE

MD2012

Manual with Automatic
Backup Inflation Model

USCG APPROVALS:

RECREATIONAL: TYPE V WITH
TYPE III PERFORMANCE
APPROVED ONLY WHEN WORN,
SPECIAL USE DEVICE



**DO NOT REMOVE PRIOR TO SALE.
DO NOT CONVERT OR ALTER THIS PFD.**

The MD2010 device will not inflate automatically upon immersion.
Tab must be pulled to activate inflation mechanism.

mustangsurvival.com

WE SAVE LIVES FOR A LIVING

CONTENTS

APPROVAL CONDITIONS AND CARRIAGE REGULATIONS.....	1
MANDATORY CARRIAGE REQUIREMENTS.....	1
WHAT IS AN INFLATABLE PFD?	2
INSTRUCTIONS FOR USE.....	2
Check Your Inflatable PFD Before Using It	2
Sizing and Fit	4
Donning Instructions.....	4
Inflating Your Inflatable PFD	6
Re-arming Your PFD After Manual Inflation (MD2010)	7
Special Consideration for Automatic Devices (MD2012)	7
Re-arming Your PFD as Manual with Automatic Backup (MD2012)	8
Deflating the Inflatable PFD	10
Repacking	11
Usage Below Freezing	11
IS YOUR PFD IN GOOD AND SERVICEABLE CONDITION?	11
CARE AND MAINTENANCE INSTRUCTIONS	12
MUSTANG ACCESSORIES.....	13
CLEANING AND STORING OF YOUR INFLATABLE PFD (MD2010)	13

CLEANING AND STORING OF YOUR INFLATABLE PFD (MD2012)	13
WHY ARE PFD'S REQUIRED SAFETY EQUIPMENT?.....	14
HOW AND WHY TO TEST YOUR PFD	14
(MD2010)	15
(MD2012)	15
HOW DO YOU TEST YOUR PFD USING THE MANUAL INFLATOR?.....	15
HOW DO YOU TEST YOUR PFD USING THE AUTOMATIC INFLATOR? (MD2012)	16
HOW DO YOU TEST YOUR PFD USING THE ORAL INFLATOR?.....	17
WEAR YOUR PFD	17
HYPOTHERMIA.....	18
EACH OF THESE DEVICES IS INTENDED TO HELP YOU SAVE YOUR OWN LIFE	19
ADDITIONAL INFORMATION	20
DO NOT ATTACH PFD'S TO YOUR BOAT	20
AIRLINE OPERATOR POLICY ON CARRIAGE OF INFLATABLE PDF'S AND CO ₂ CARTRIDGES.....	20

APPROVAL CONDITIONS AND CARRIAGE REGULATIONS

This inflatable PFD is approved by the U.S. Coast Guard for use as a Type V Personal Flotation Device (PFD). It is not approved for water skiing or other high impact, high speed activities. This inflatable PFD was designed to be more comfortable and less restrictive to wear than inherently buoyant PFDs. When worn, used, and serviced according to this owner's manual, this PFD can greatly increase your chances of survival in the water. Not recommended for non-swimmers or weak swimmers. Users of inflatable PFDs must be at least 16 years old.

A Type V PFD must be worn to count as an approved PFD.

MANDATORY CARRIAGE REQUIREMENTS

Federal regulations in 33 CFR 175-1993 require you to carry Coast Guard approved personal flotation devices (PFDs) legibly marked with the Coast Guard approval number which are in good and serviceable condition and are the correct size for each person on board. To be considered serviceable, this Inflatable PFD shall not exhibit deterioration that could diminish its performance such as broken or deformed hardware, detached webbing, rotted structural components, air leaks, or nonfunctional oral inflation tube. Unless worn inflated, this Inflatable PFD must also be properly armed with a full CO2 cylinder, inflation system status indicator, and an accessible manual inflation lanyard. A PFD which is "approved only when worn" or "required to be worn" must be worn under the specified conditions.

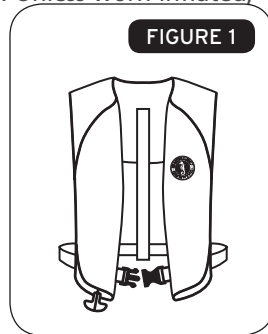

WHAT IS AN INFLATABLE PFD?

While traditional PFDs are inherently buoyant, inflatable PFDs rely entirely on inflation for buoyancy. Uninflated, the Inflatable PFD is a comfortable slim collar that can be inflated at any time with a 20 gram CO₂ gas cylinder. The Inflatable PFD is designed to offer maximum mobility with minimum bulk. The Inflatable PFD (MD2010) can be inflated either manually by jerking a pull-tab, or orally (by mouth). The Inflatable PFD (MD2012) can be inflated either automatically during water immersion, manually by jerking a pull-tab, or orally by mouth. It is recommended that you familiarize yourself with the procedures outlined in INSTRUCTIONS FOR USE (p. 2).

INSTRUCTIONS FOR USE

This manual supplies instructional, maintenance and safety information for both models (MD2010 and MD2012) unless specified otherwise. The model number is listed on the back of the inflatable PFD.

Check Your Inflatable PFD Before Using It

After purchasing your Inflatable PFD, make sure it has an unused 20 gram cylinder attached to the inflator mechanism (Fig. 2 for the MD2010) (Fig. 6 for the MD2012).

Check the components and how to assemble the inflator by following these steps:

1. Undo the Velcro™ tabs on the wearer's right-hand side of the collar to expose the inflator (Fig. 3).
2. Unscrew and remove the CO₂ gas cylinder from the inflator and inspect its small end. If it is pierced (Fig. 4), replace it!

For the MD2012 only – Examine the auto cap. Ensure that the cap is screwed hand tight onto the inflator. If the auto cap indicator (Fig. 8) shows red, the auto capsule mechanism has been fired or is incorrectly screwed on. If spent, replace the bobbin before proceeding (Fig. 6). **If either of these conditions exist, the auto cap must be re-screwed or the bobbin replaced!**

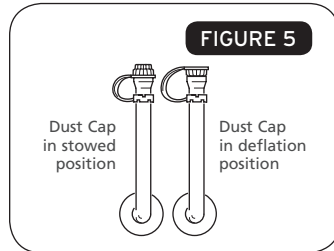
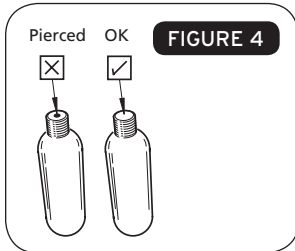
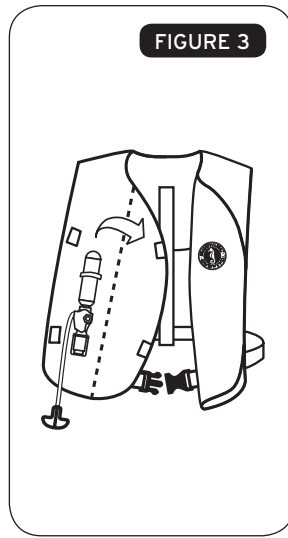
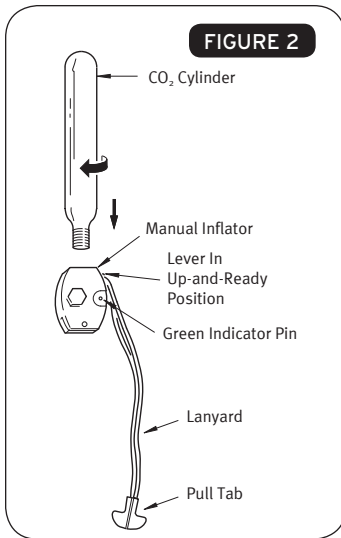

3. If your inflator has a metallic lever attached to the pull tab, make sure the lever is in the up-and-ready position and insert the green indicator pin if not already in place. Make sure the CO₂ cylinder is screwed hand tight into the inflator (Fig. 2 for the MD2010)
4. If your inflator has a red lever attached to the pull tab, make sure the red lever is retracted and insert the green indicator clip over the red lever if not already in place. Make sure the CO₂ cylinder is screwed hand tight into the inflator (Fig. 6 for the MD2012).

IMPORTANT! Ensure the PFD is properly armed with all indicators showing green.

5. Check that the oral-inflation dust cap is properly in the stowed position (Fig. 5).
6. Refold the front flap and fasten with Velcro™. Refer to the Repacking instructions (p. 11). If everything checks out, your Inflatable PFD is ready for use.

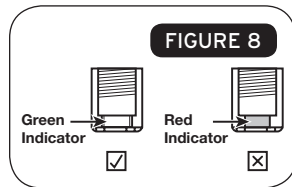
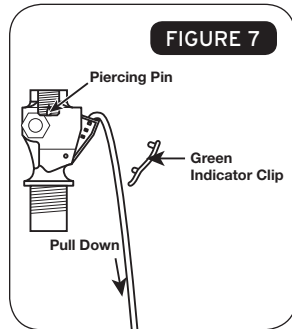
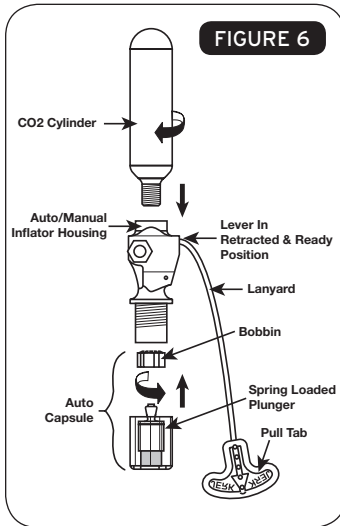

SIZING AND FIT

The PFD provides a minimum of 22.5 lbs of buoyancy and is designed for wearers with a chest range of 30-52 inches weighing over 80 pounds.

DONNING INSTRUCTIONS

It is important that the PFD is properly adjusted to fit the person wearing it. An incorrect fit or improper fastening of attachments could impede its effectiveness.

1. All belts and straps are already threaded correctly and only need to be adjusted for fit. The waist belt should fit securely.

- Put the Inflatable PFD on just like a jacket (Fig. 9) and fasten the front buckle. Adjust the waist belt using the side buckle on the belt and secure the belt's loose end in the belt loop.

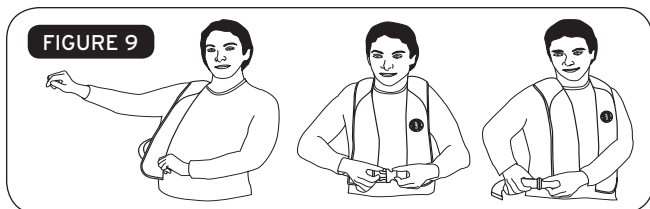

- Check to be sure the device is flat against the body and is not twisted (Fig. 10).

Warning: Do not wear Inflatable PFDs under clothing as the inflation could be restricted or you could be injured.

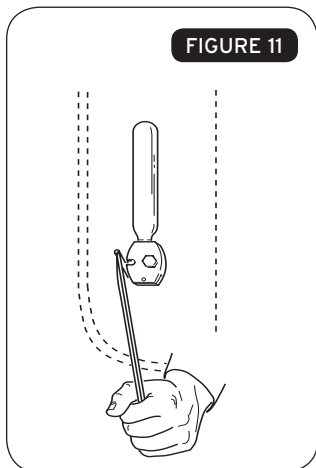

MD2010 MANUAL INFLATION

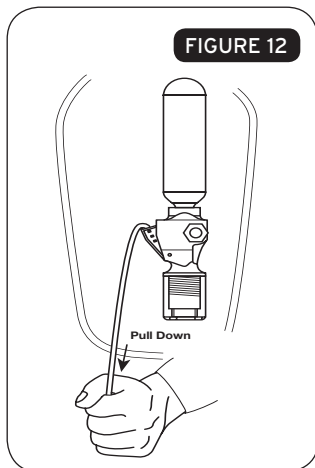

MD2012 MANUAL INFLATION

INFLATING YOUR INFLATABLE PFD

Practice inflating the device. It is recommended that the following procedures are followed to inflate your inflatable PFD:

1. Manual inflation

Actuate the inflation system by jerking firmly downward on the pull tab. The PFD should fully inflate within 5 seconds (Fig. 11 for the MD2010, Fig. 12 for the MD2012)

2. Oral inflation

Properly armed and inspected, manual Inflatable PFD models will inflate. However, should inflation not occur, or in a non-emergency situation, you can fully inflate the PFD by mouth (Fig. 13). To orally inflate the PFD, first locate the oral inflation tube by opening the wearer's left front panel of the PFD. Then remove the dust cap from the end of the oral tube and blow into the tube until the PFD is fully inflated.

3. Automatic backup inflation (MD2012 only)

Inflation will occur automatically within seconds after the inflator is immersed in water. The water-sensing bobbin will disintegrate, triggering a spring-loaded plunger, which punctures the CO₂ cylinder to inflate the cell (Fig. 4).

Information for both models: The carbon dioxide used to inflate PFDs will slowly permeate through the fabric cell over time. A slight reduction of pressure will be observed after several hours of inflation. Topping up by oral inflation may be required in the event of very prolonged immersion.

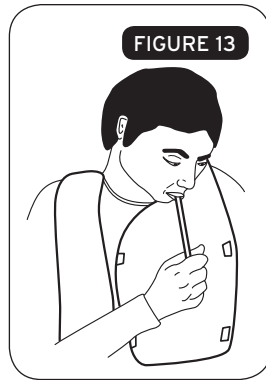

Re-arming Your PFD After Manual Inflation (MD2010)

1. To re-arm your Mustang Inflatable PFD, unscrew and discard the used CO2 cylinder.
2. To check that the inflator is fully operational, pull down on the lanyard and see if the piercing pin travels freely (Fig. 14). Both the pin and the lever should easily return to their original position.
3. After using your Mustang Inflatable PFD, always rinse it with tap water to remove dirt and salt. Let the PFD air-dry before re-arming with new CO2 cylinder.

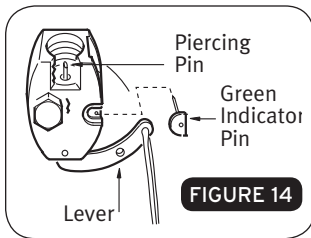

MANUAL MODEL

4. Make sure the manual inflator lever is in the up-and-ready position and the green indicator pin has been replaced. Screw the new CO2 cylinder hand tight into the inflator. Do not over-tighten as this can damage the internal gasket.

5. Refold the PFD according to the repacking instructions.

Special Consideration for Automatic Devices (MD2012)

Premature automatic inflation causes several risks that you must address to avoid drowning. The PFD might not be armed when needed, either knowingly or unknowingly. Much less common but also important are:

1. Double inflation (CO2 cylinder inflation after full oral inflation) could damage the PFD,
2. Inflation when stored in a tight space could damage the PFD, and
3. The PFD could inflate when you are in an awkward place or position. Inadvertant inflation may occur in certain conditions, including when the device is:
 - Subjected to splashing
 - In heavy fog
 - In high humidity
 - In the rain

Care and attention should be taken to ensure that when the device is used in these types of conditions, auto-inflation does not occur inadvertently.

If this Inflatable PFD (MD2012) should inflate prematurely, a re-arm kit (MA2012) is required to re-arm the device.

Important: The Inflatable PFD should be re-armed according to the instructions (Re-arming Your PFD as Manual with Automatic Backup (MD2012)).

The automatic inflator bobbin should be replaced at least once every twelve months.

Re-arming Your PFD as Manual with Automatic Backup (MD2012)

See Fig. 15 for referenced parts in each step.

Step 1: Unpack or open the life vest so that the automatic inflator is visible.

Step 2: Remove empty gas CO2 cylinder by firmly rotating cylinder counterclockwise. **Discard cylinder.**

Step 3: Remove clear cap by turning counterclockwise.

Step 4: Remove bobbin (yellow) from cap or housing unit. If the bobbin is used, damaged, or more than 4 years old, **discard it.** Store unused bobbins in a cool dry area when not in use. Check the housing to be sure it is clear and dry.

Note: The bobbin (yellow) body may remain in the housing or in the cap assembly when you remove the cap. The bobbin body must be removed prior to assembly.

Step 5: Check the date on the bobbin in the rearm kit. The date should not be over four (4) years from today's date.

Step 6: IMPORTANT! Bobbin (yellow) must be installed into the Housing (see Fig 15), white side down facing away from the inflator towards the cap (clear), aligning the slots on the bobbin with the ridges inside the threaded housing. The bobbin will slide in easily if installed correctly.

FIGURE 15

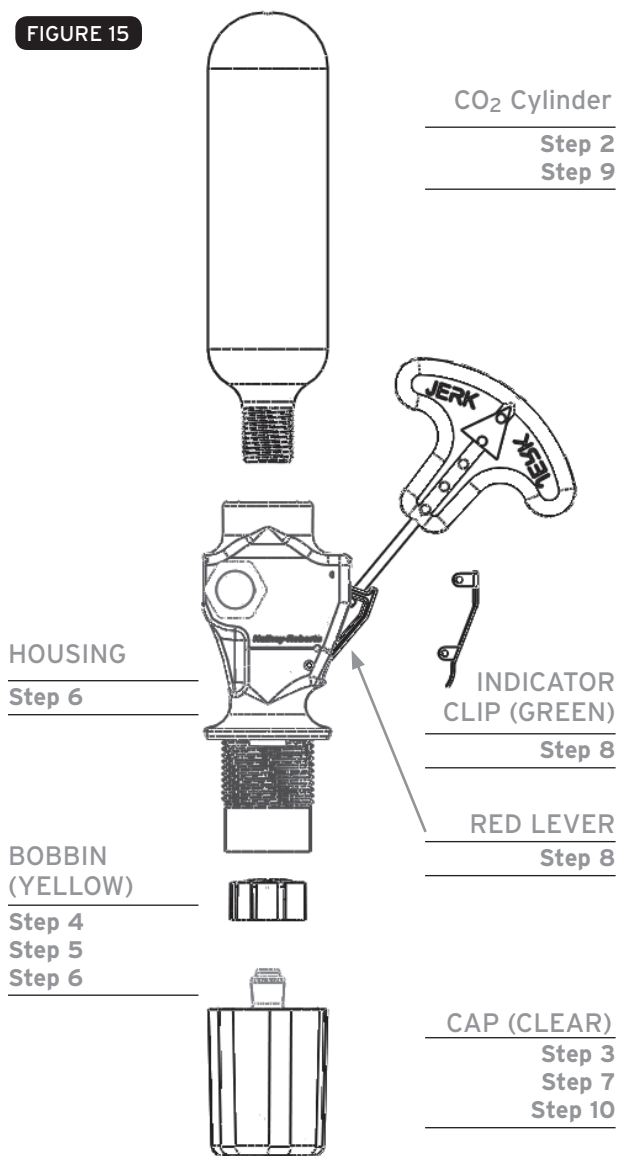

Step 7: Install clear cap by screwing clockwise until it meets the housing shoulder.

Note: No gap.

Step 8: Place the green indicator clip over the red lever by aligning the arms on the clip with the slots in the inflator (see Fig 15). Push firmly in the middle of the clip to snap in place.

Step 9: Install an unused cylinder by rotating clockwise into inflator until cylinder is secured firmly in inflator.

Step 10: Check to be sure service indicator is green and green indicator clip is firmly attached.

YOUR PFD IS NOW READY FOR MANUAL USE WITH AUTOMATIC BACKUP

DEFLATING THE INFLATABLE PFD

1. To deflate the Inflatable PFD, reverse the oral-inflation tube dust cap and insert it into the valve or depress valve with fingertip. The dust cap will not lock in the deflate position so it is necessary to hold it in place (Fig. 16).
2. Gently squeeze the Inflatable PFD until all air or gas has been expelled. To avoid damage, do not wring or twist the Inflatable PFD.
3. Put the inflation tube dust cap back in its stowed position on the oral inflation tube (Fig. 5).
4. Your device is ready to be repacked (see Repacking p. 11).

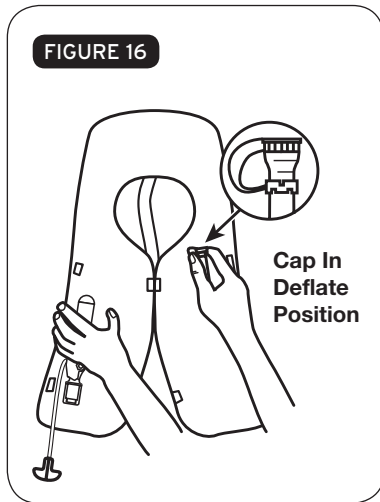

REPACKING

Before repacking, completely deflate the inflation cell. Force excess air out through the inflation tube (Fig. 16). Do not wring cell. Put the inflation tube cap back in the stowed position (Fig. 5).

Note: Before following the repacking sequence, be sure to properly re-arm your Inflatable PFD.

1. Fold lapel (A) back along the dotted line (Fig. 17).

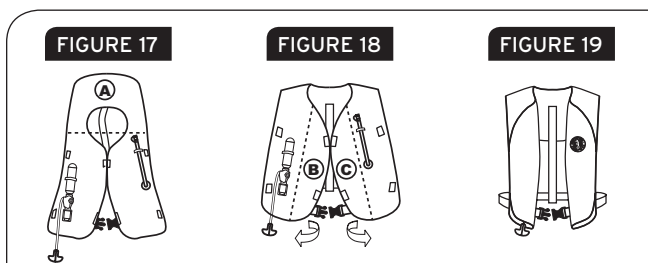

2. Fold sides (B) and (C) outward along dotted lines. Secure with Velcro™.
3. Make sure the inflator pull-tab is on the outside of the folded PFD. Fig. 19 depicts a correctly folded PFD.

Usage Below Freezing

When the temperature is below freezing, a fully discharged cylinder may not adequately inflate your Inflatable PFD. Under these conditions use the oral inflator to adequately top-up the PFD.

Warning: CO₂ inflation could over-pressurize and damage your Inflatable PFD if already orally inflated.

IS YOUR PFD IN GOOD AND SERVICEABLE CONDITION?

Check your PFD between outings to be sure that it is properly armed; that it is free of rips, tears or holes; that all seams are securely sewn; and that the fabric, straps and hardware are still strong. Inspect the inflatable

portion of the PFD in accordance with the CARE AND MAINTENANCE INSTRUCTIONS (p. 12).

CARE AND MAINTENANCE INSTRUCTIONS

Check the following at the intervals listed below.

1. Each Use: Remove and inspect the CO2 cylinder from the inflator. For the MD2012 – Also remove the clear auto cap and bobbin from the inflator.
 - i. Check all components for dirt or corrosion. Clean or replace.
 - ii. Check that the CO2 cylinder has not been pierced. Replace with Inflatable PFD 20 gram CO2 cylinder if necessary. The cylinder for the MD2010 is contained in accessory pack MA2010. The cylinder for the MD2012 is contained in accessory pack MA2012.
 - iii. If your PFD has a metal lever attached to the pull tab, check the lever to ensure it is in the up and ready position with the green indicator pin properly installed.
 - iv. If your PFD has a red lever attached to the pull tab, check the lever to ensure it is retracted with the green indicator clip properly installed.
2. Every Three (3) Months: Leak Test the Inflatable PFD every three months.
 - i. Orally inflate your Inflatable PFD until firm and let stand overnight. A leaking Inflatable PFD will not hold its firmness and should be replaced. If your Inflatable PFD leaks, take it to your Mustang dealer for evaluation and/or servicing. Repack the Inflatable PFD as outlined in the Repacking section (p. 11).
3. Annually:
 - i. To check the oral inflation valve, fully inflate PFD and hold valve under water. If bubbles appear, deflate and reinflate to test again. Should the leak persist, take your Inflatable PFD to your dealer for proper servicing.

- ii. Visually examine your PFD for damage or excessive abrasion, wear, tear or contamination. Particular attention must be paid to the stitching. If in doubt, send it to your Mustang dealer for evaluation and/or servicing.
- iii. Replace the automatic inflator bobbin.

Re-assemble inflation system parts and repack PFD as outlined in previous instructions and illustrations.

Warning: If you are not confident in the self inspection and servicing of your Inflatable PFD, in accordance with these instructions, take your Inflatable PFD to a Mustang dealer for professional servicing or contact Mustang Survival (see contact information on back of manual).

MUSTANG ACCESSORIES

The MD2010 requires re-arm kit MA2010 and the MD2012 requires rearm kit MA2012.

Cleaning and Storing of Your Inflatable PFD (MD2010)

To clean your Inflatable PFD, remove the CO2 cylinder. Hand wash or sponge down the Inflatable PFD in warm water and rinse with clean water. Hang to dry on a plastic coat hanger. Be sure to replace CO2 cylinder. See Re-arming your PFD After Manual Inflation (MD2010) (p. 7).

Always store your Inflatable PFD in a warm, dry place out of direct sunlight.

Cleaning and Storing of Your Inflatable PFD (MD2012)

To clean your Inflatable PFD, remove the CO2 cylinder, auto-cap and bobbin. Keep the bobbin dry. Hand wash or sponge down the Inflatable PFD in warm water. Rinse the PFD and inflator with clean water. Hang the Inflatable PFD to dry on a plastic coat hanger. Ensure the inflator is thoroughly dry before installing the bobbin.

Be sure to replace CO2 cylinder, auto-cap and bobbin (see Re-arming your PFD (MD2012) as Manual with Automatic Backup).

Always store your Inflatable PFD in a warm, dry place out of direct sunlight.

WHY ARE PFDs REQUIRED SAFETY EQUIPMENT?

Drownings are the leading cause of fatalities involving recreational boating. A PFD provides flotation to help keep your head above water, help you to stay face up in the water, and increase your chances for survival and rescue. Most adults only need an extra 7 to 12 pounds (3.2 to 5.5 kg) of flotation to keep their heads above water. The proper size PFD will properly support the weight of the wearer.

Since this Inflatable PFD does not have inherent buoyancy, it provides flotation only when inflated. Familiarize yourself with the use of this Inflatable PFD so you know what to do in an emergency.

HOW AND WHY TO TEST YOUR PFD

Inflate your Inflatable PFD and try it out in the water to learn how it works by:

Making sure it floats you:

- Comfortably (when worn properly)
- Adequately for expected wave conditions (body shapes/densities affect performance)

Making sure it works:

- A flow of bubbles should not appear (see CARE AND MAINTENANCE INSTRUCTIONS for leak tests p. 12). It should inflate quick and easily.

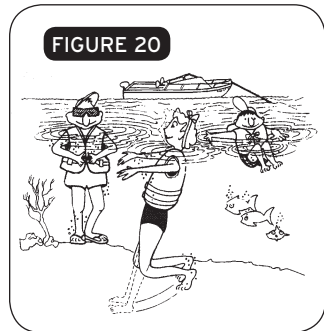

- Activating the CO2 inflation system
- Re-arming the CO2 inflation system
- Using the oral inflator tube

To check the manual inflation system (with CO2 cylinder removed and green pin or clip removed); determine that the CO2 cylinder piercing pin and arm moves freely when moving the lever (attached to the pull-tab) several times down and up for the MD2010 (Fig. 14) and for MD2012, several times in and out (Fig. 7). Repeat this several times to check the manual inflation system.

MODEL MD2010

The U.S. Coast Guard recommends that you purchase two re-arming kits (MA2010). One kit is to be used immediately in testing the inflation system (see HOW DO YOU TEST YOUR PFD USING THE MANUAL INFLATOR?, (p. 16) and the other to carry on board as a spare.

MODEL MD2012

The U.S. Coast Guard recommends that you purchase two automatic re-arming kits (MA2012). One kit is to be used immediately in testing the automatic inflation system (see HOW DO YOU TEST YOUR PFD USING THE AUTOMATIC INFLATOR?, p. 16) and the other to carry on board as a spare.

The U.S. Coast Guard recommends you test the automatic inflation system in the water at the beginning of each boating season. By doing this, you demonstrate that the automatic inflation system is still working properly and reduce the likelihood of premature inflation and its associated dangers.

HOW DO YOU TEST YOUR PFD USING THE MANUAL INFLATOR?

1. To test your Inflatable PFD, you will need your fully armed Inflatable PFD, and re-arming kit approved for your Inflatable PFD: MA2010 for model MD2010 and MA2012 for model MD2012.
2. Put on the Inflatable PFD.

3. Actuate the inflation system by jerking firmly downward on the pull-tab. The Inflatable PFD should fully inflate within 5 seconds.
4. Get into shallow water, just deep enough that you can stand with your head above the surface.
5. See if the Inflatable PFD will float you on your back or just slightly back of vertical. In a relaxed floating position, verify that your mouth is well above the water's surface. Note the effect of where you hold your legs on how you float.
6. Get out of the water and remove the Inflatable PFD. Completely deflate the Inflatable PFD using the oral inflator (see Deflating the Inflatable PFD p. 10). Remove the CO2 cylinder from the inflator.
7. Let the Inflatable PFD dry thoroughly. Re-arm (for your model) and Repack (p. 11) the PFD.

HOW DO YOU TEST YOUR PFD USING THE AUTOMATIC INFLATOR? (MD2012)

1. To test your Inflatable PFD, you will need your fully armed Inflatable PFD, and re-arming kit (MA2012) approved for your Inflatable PFD
2. Put on the Inflatable PFD.
3. Get into shallow water, just deep enough that you can stand with your head above the surface. Once the inflator is underwater the Inflatable PFD should fully inflate automatically within 10 seconds.
4. See if the Inflatable PFD will float you on your back or just slightly back of vertical. In a relaxed floating position, verify that your mouth is well above the water's surface. Note the effect of where you hold your legs on how you float.
5. Get out of the water and remove the Inflatable PFD. Remove the used CO2 cylinder and the used bobbin from the Inflatable PFD inflator.

Deflate the Inflatable PFD (see Deflating the Inflatable PFD p. 10).

6. Let the Inflatable PFD dry thoroughly. Re-arm (for your model) and Repack the PFD (p. 11).

HOW DO YOU TEST YOUR PFD USING THE ORAL INFLATOR?

1. No spare parts or re-arming kits are needed to test your Inflatable PFD, using the oral inflator.
2. Remove the CO2 cylinder to prevent inadvertent inflation, which could potentially damage the Inflatable PFD. Inspect the cylinder to confirm it is unused (Fig. 4). Unscrew the clear auto cap and remove the bobbin (MD2012). Otherwise the bobbin will disintegrate during water immersion.
3. Put on the Inflatable PFD.
4. Get into shallow water, just deep enough that you can stand with your head above the surface.
5. If you are a weak swimmer or non-swimmer, orally inflate the Inflatable PFD partially so that you are supported well enough to be able to complete inflation without touching bottom. Note this level of inflation because it is the minimum needed for you to safely use this Inflatable PFD.
6. Fully inflate the Inflatable PFD using the oral inflator.
7. See if the Inflatable PFD will float you on your back or just slightly back of vertical. In a relaxed floating position, verify that your mouth is well above the water's surface. Note the effect of where you hold your legs on how you float.
8. Get out of the water and remove the Inflatable PFD. Completely deflate the Inflatable PFD (see Deflating the Inflatable PFD p. 10).
9. Let the Inflatable PFD dry thoroughly. Re-arm (for your model) and Repack the PFD (p. 11).

WEAR YOUR PFD

In approximately 80 percent of all boating fatalities, the victims were not wearing a PFD. Most fatal accidents happen on calm sunny days. This Inflatable PFD is much more comfortable to wear than other PFD types. Get into the habit of wearing this Inflatable PFD.

Non-swimmers and children especially should wear a hybrid or non-Inflatable PFD at all times when on or near the water.

HYPOTHERMIA

Prolonged exposure to cold water causes a condition known as hypothermia — a substantial loss of body heat, which leads to exhaustion and unconsciousness. Most drowning victims first suffer from hypothermia. The following chart shows the effects of hypothermia: how hypothermia affects most adults.

How hypothermia affects most adults

<i>Water Temperature</i> °C (°F)		<i>Exhaustion or Unconsciousness</i>	<i>Expected Time of Survival</i>
0.3	(32.5)	Under 15 min.	Under 15–45 min.
0.3–4	(32.5–40)	15–30 min.	30–90 min.
4–10	(40–50)	30–60 min.	1–3 hrs
10–16	(50–60)	1–2 hrs.	1–6 hrs.
16–21	(60–70)	2–7 hrs.	2–40 hrs.
21–27	(70–80)	2–12 hrs.	3 hrs. to Indefinite
over 27	(over 80)	Indefinite	Indefinite

PFDs can increase survival time because they allow you to float without using energy treading water and because of their insulating properties. Naturally, the warmer the water, the less insulation you will require. When operating in cold waters [below 60°F (15.6°C)] you should consider using a coat or jacket style PFD or a Type V Thermal Protective PFD as they cover more of the body than the vest or belt style PFDs. Some Points to Remember About Hypothermia Protection:

1. Always wear your Inflatable PFD. Even if you become incapacitated due to hypothermia, the Inflatable PFD will keep you afloat and greatly improve your chances of rescue.
2. Do not attempt to swim unless it is to reach a nearby craft, fellow survivor, or a floating object on which you can lean or climb. Swimming increases the rate of body heat loss. In cold water, drown-proofing methods that require putting your head in the water are not recommended. Keep your head out of the water. This will greatly lessen heat loss and increase your survival time.

3. Use the standard H.E.L.P. position when wearing an Inflatable PFD, drawing the legs up to a seated position, because doing so will help you conserve body heat (Fig. 21).
4. Keep a positive attitude about your survival and rescue. This will improve your chances of extending your survival time until rescued. Your will-to-live does make a difference!
5. If there is more than one person in the water, huddling is recommended while waiting to be rescued. This action tends to reduce the rate of heat loss and thus increase the survival time.



EACH OF THESE DEVICES IS INTENDED TO HELP YOU SAVE YOUR OWN LIFE

For your Inflatable PFD to function properly, follow these suggestions to verify that it fits, floats, and remains in good condition.

1. Check the inflation mechanism status indicators before each use.
2. Get in the habit of re-arming the inflation mechanism right after each inflation.
3. Try your wearable Inflatable PFD on and adjust it until it fits comfortably in and out of the water.
4. Mark your Inflatable PFD with your name if you are the only wearer.
5. Do not alter your Inflatable PFD. If it doesn't fit properly, get one that does. An altered device is no longer Coast Guard approved.
6. Your Inflatable PFD is not intended for use as a fender or kneeling pad.
7. If your Inflatable PFD is wet, allow it to dry thoroughly before storing it. Store it in a well-ventilated area.

8. Do not dry your Inflatable PFD in front of a radiator or other source of direct heat.

ADDITIONAL INFORMATION

If you need more information about PFDs and safe boating, contact your state boating authority, U.S. Coast Guard Auxiliary, U.S. Power Squadron, Red Cross, or your nearest unit of the U.S. Coast Guard. To find out about free boating courses in your area call 1-800-336-BOAT (in Virginia, call 1-800-245-BOAT).

DO NOT ATTACH PFD'S TO YOUR BOAT

Each PFD has straps, hooks, buckles, or other means for securing the device in place on the wearer. Some PFDs also incorporate decorative d-rings or tabs. Such items are not to be used to attach the device to the boat. Attaching the device to the boat will not permit it to perform as intended.

AIRLINE OPERATOR POLICY ON CARRIAGE OF INFLATABLE PFDs AND CO₂ CARTRIDGES

Please be aware that the following regulations apply to the air transport of this product. According to

U.S. Research and Special Programs Administration Regulations Title 49 CFR 75.10(a)(25): With the approval of the aircraft operator, one small carbon dioxide cylinder fitted into a self-inflating jacket, plus one spare cartridge, may be carried by a passenger or crew in checked or carry-on baggage.

Please refer to the governing body's documentation, found online at <http://hazmat.dot.gov>.



WE SAVE LIVES FOR A LIVING
mustangsurvival.com

TOLL FREE 1.800.526.0532 | EMAIL custserv@mustangsurvival.com

Mustang Survival and seahorse design is a registered trademark of Mustang Survival Corp.

Our commitment to quality has earned our Burnaby facilities ISO 9001 registration, the highest of all international standards. This is our guarantee you're receiving the ultimate in design and manufacturing.