

MegaRAID[®] SAS 8344ELP RAID Controller

Quick Installation Guide

LSI LOGIC[®]

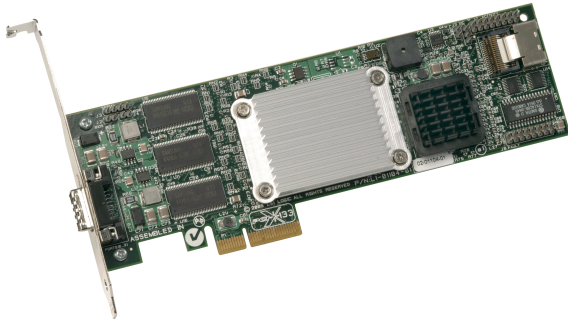

Thank you for purchasing the MegaRAID[®] SAS (Serial Attached SCSI/Serial ATA) 8344ELP (PCI Express low-profile) RAID Controller. Please take a few minutes to read this quick installation guide before you install the controller. If you need more information about any topic covered in this guide, refer to the related documents on your *MegaRAID Universal Software Suite* CD.

Note: This is a PCI Express x4 card, so it fits only in a PCI Express x4 or greater slot.

Note: SATA II is the only type of SATA supported by the SAS 8344ELP Controller.

You can use the intelligent Battery Backup Unit 01 (LSIiBBU01) with the SAS 8344ELP. For more information about this battery, refer to the *MegaRAID Battery Backup Unit User's Guide* on the *MegaRAID Universal Software Suite* CD.

MegaRAID SAS 8344ELP RAID CONTROLLER INSTALLATION

 Make a backup of your data before you change your system configuration. Otherwise, you may lose data.

Step 1 Unpack the MegaRAID SAS 8344ELP RAID Controller

Unpack the controller in a static-free environment. Remove it from the antistatic bag and inspect it for damage.

If the controller appears to be damaged, or if the *MegaRAID Universal Software Suite* CD is missing, contact LSI Logic or your MegaRAID OEM support representative.

The CD contains utility programs, device drivers for various operating systems, and the following documentation:

- *MegaRAID SAS Storage Adapters User's Guide*
- *MegaRAID SAS Software User's Guide*
- *MegaRAID SAS Device Driver Installation User's Guide*
- Software license agreement

Step 2 Prepare the Computer

Turn off the computer and unplug the power cord(s) from the back of the power supply. Remove the cover from the computer.

 Make sure the computer is disconnected from the power and from any networks before installing the controller.

Step 3 Review the Jumpers and Connectors

Figure 1 shows the location of the jumpers and connectors on the SAS 8344ELP. The jumpers are set at the factory and you usually do not need to change them.

Figure 1 MegaRAID SAS 8344ELP RAID Controller Card Layout

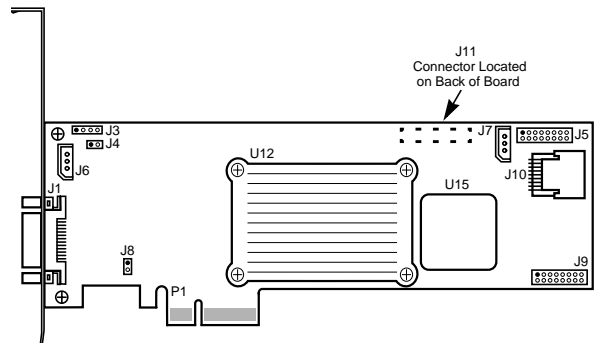

Note: J11, the battery backup connector, is located on the back side of the SAS 8344ELP.

MEGARAIID

The following table describes the jumpers and connectors on the SAS 8344ELP.

Jumper/ Connector	Type	Description
J1	SAS 8344ELP Ports	Ports 0–3. The ports connect the cables from the adapter to SAS or SATA II physical drives, or a port multiplier.
J2	BIOS Disable header	2-pin header. The BIOS function is enabled or disabled in software depending on the status of this jumper. No jumper: BIOS is enabled (default). Jumper: BIOS is disabled. Note: The card does not function as a RAID controller if this jumper is mounted.
J3	Serial header for debug use	4-pin header. Used for diagnostic purposes. The serial port is not RS232 voltage level compliant.
J4	Mode Select header	2-pin connector. If the firmware flashed onto the board is corrupted, you need to jumper J4 (this holds the CPU core in reset), so you can flash the firmware. Remove the jumper after you flash the new firmware. No jumper: This is the setting during normal operation (Mode 3). This is the default. Jumper: This holds the CPU core in reset (Mode 0). Note: The card does not function as a RAID controller if this jumper is mounted.
J5	Individual Activity LED header for all eight ports	16-pin (8x2) header. Provides LED interface individually to eight SATA II ports. The LED indicates activity on specific ports.
J6	IPMI-style SMBus (System Management) /I ² C header	3-pin header. Provides enclosure management support.
J7	IPMI-style LSI1068 SMBUS debug header	3-pin header. Used for diagnostic purposes.
J8	Cache Write Pending LED	2-pin connector. Connector for enclosure LED. Provides a signal that indicates when the on-board cache contains data and a write from the cache to the hard drives is pending. Optional.
J9	LED Drive Fault Connector Interface	16-pin (8x2) connector. Provides LED interface individually to eight SATA II ports. The LED indicates a drive fault on particular ports.
J10	SAS 8344ELP Ports	Ports 4–7. The ports connect the cables from the adapter to the SATA II physical drives or port multiplier.
J11	Battery Backup Connector (located on the back side of the controller)	20-pin connector. Provides interface to the remote battery pack.

Step 4 Install the MegaRAID SAS 8344ELP RAID Controller

Insert the SAS 8344ELP in a PCI-E slot on the mainboard, as shown in [Figure 2](#). Press down gently but firmly to seat the card properly in the slot. Secure the SAS 8344ELP to the computer chassis with the bracket screw.

Figure 2 Installing the MegaRAID SAS 8344ELP RAID Controller

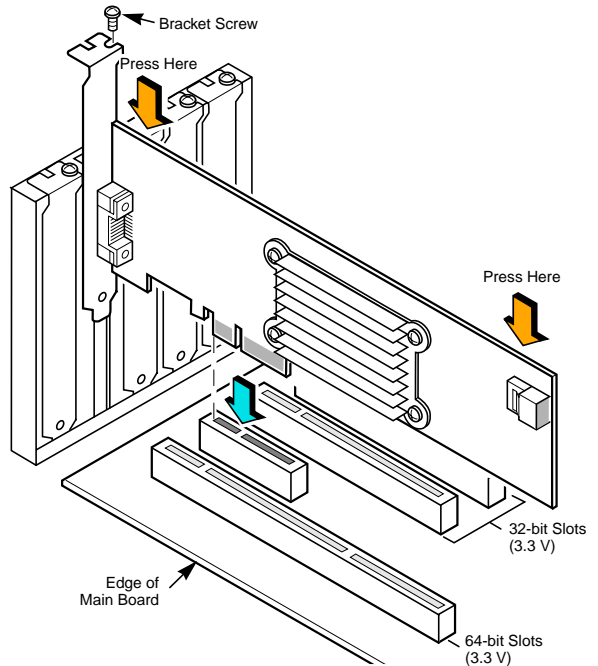

Refer to your mainboard guide for information about the PCI-E slot.

Step 5 Configure and Install SAS and/or SATA II Devices

Configure the SAS and/or SATA II devices and install them in the host system computer case. Refer to the documentation for the devices for any pre-installation configuration requirements.

Step 6 Connect the MegaRAID SAS 8344ELP RAID Controller to the SAS and/or SATA II Devices

Use SAS cables to connect the SAS 8344ELP to SAS and/or SATA II devices. Refer to [Figure 1](#) to view connector locations on the controller.

Refer to the *MegaRAID SAS Storage Adapters User's Guide* on the *MegaRAID Universal Software Suite* CD for detailed information about the SAS cables.

Step 7 Power-Up the Computer

Replace the computer cover and reconnect the power cord(s). Turn on power to the computer. Ensure that the devices are powered up before or at the same time as the host computer. If the computer is powered up before the devices, the devices might not be recognized.

During boot, a MegaRAID BIOS message similar to the following displays:

```
LSI LOGIC MEGARAID BIOS VERSION xxxx  
[date]
```

```
Copyright (c) 2005, LSI Logic Corp.
```

```
HA-1 (Bus x Dev y) LSI MegaRAID SAS  
8344ELP PCI-E
```

```
Standard FW xxxx DRAM=xxxx MB(SDRAM)
```

The firmware takes several seconds to initialize. During this time the adapter scans the Serial ATA ports.

Step 8 Run the WebBIOS Configuration Utility

Run the WebBIOS Configuration Utility to configure the physical arrays and logical drives. When the message Press <Ctrl><H> for WebBIOS displays on the screen, press CTRL+H immediately to run the utility.

Note: Refer to the *MegaRAID SAS Software User's Guide* on the *MegaRAID Universal Software Suite* CD for detailed steps on configuring physical arrays and logical drives.

Step 9 Install the Operating System Driver

The SAS 8344ELP can operate under various operating systems. To operate under these operating systems, you must install software drivers.

The *MegaRAID Universal Software Suite* CD includes drivers for the supported operating systems, along with documentation. You can view the supported operating systems and download the latest drivers for RAID adapters on the LSI Logic web site at:

<http://www.lsillogic.com/downloads/main.do>.

Access the download center and follow the steps to download the driver.

Refer to the *MegaRAID SAS Device Driver Installation User's Guide* on the *MegaRAID Universal Software Suite* CD for details on installing the driver. Be sure to use the latest Service Packs provided by the operating system manufacturer and review the `readme` file that accompanies the driver.

SUPPORTED RAID LEVELS

The SAS 8344ELP supports disk arrays using the following RAID levels:

- **RAID 0 (Data striping):** Data is striped across all disks in the array, enabling very fast data throughput. There is no data redundancy. All data is lost if any disk fails.
- **RAID 1 (Disk mirroring):** Data is written simultaneously to two disks, providing complete data redundancy if one disk fails. The maximum array capacity is equal to the available size of the smaller of the two hard drives.
- **RAID 5 (Disk striping with distributed parity):** Data is striped across all disks in the array. Part of the capacity of each disk stores parity information that reconstructs data if a disk fails. Provides good data throughput for applications with high read request rates.
- **RAID 10 (RAID 1 and RAID 0 in spanned arrays):** Uses mirrored pairs of disks to provide complete data redundancy. Provides high data throughput rates.
- **RAID 50 (RAID 5 and RAID 0 in spanned arrays):** Uses both parity and disk striping across multiple disks to provide complete data redundancy. Provides high data throughput rates.

TECHNICAL SUPPORT

For assistance installing, configuring, or running the SAS 8344ELP, contact LSI Technical Support:

E-mail:

support@lsil.com

eurosupport@lsil.com (Europe)

Phone Support:

1-800-633-4545 (North America)

+44 1344 413 441 (Europe)

Web Site:

<http://www.lsillogic.com/support/>



PN: 80-00112-01 Rev. A

DB11-000072-01, Version 2.0, February 2006

Find a list of LSI Logic Corporation's U.S. distributors, international distributors, sales offices, and design resource centers on the LSI Logic web site at:

<http://www.lsillogic.com/contacts/index.html>

LSI Logic, the LSI Logic logo design, and MegaRAID are registered trademarks of LSI Logic Corporation. All other brand and product names may be trademarks of their respective companies.

Copyright © 2005-2006 by LSI Logic Corporation. All rights reserved.

LSI Logic products are not intended for use in life-support appliances, devices, or systems. Use of any LSI Logic product in such applications without written consent of the appropriate LSI Logic officer is prohibited.

Purchase of I²C components of LSI Logic Corporation, or one of its sublicensed Associated Companies, conveys a license under the Philips I²C Patent Rights to use these components in an I²C system, provided that the system conforms to the I²C standard Specification as defined by Philips.

LSI Logic Corporation reserves the right to make changes to any products and services herein at any time without notice. LSI Logic does not assume any responsibility or liability arising out of the application or use of any product or service described herein, except as expressly agreed to in writing by LSI Logic; nor does the purchase, lease, or use of a product or service from LSI Logic convey a license under any patent rights, copyrights, trademark rights, or any other of the intellectual property rights of LSI Logic or of third parties.