



.....  
***ST3390N, ST3655N***

.....  
***SCSI Interface Drive***

.....  
***Installation Guide***

---

---

## Contents

<b><i>Read before you begin</i></b> . . . . .	<b>1</b>
<b>Configuring the drive</b> . . . . .	<b>2</b>
<b>Attaching cables</b> . . . . .	<b>5</b>
<b>Mounting the drive</b> . . . . .	<b>8</b>
<b>CMOS setup for AT systems</b> . . . . .	<b>10</b>
<b>Physical geometry for non-DOS operating systems</b> . . . . .	<b>10</b>
<b>Low-level formatting</b> . . . . .	<b>10</b>
<b>Partitioning</b> . . . . .	<b>11</b>
<b>High-level formatting</b> . . . . .	<b>11</b>
<b>Troubleshooting</b> . . . . .	<b>12</b>
<b>Technical support services</b> . . . . .	<b>16</b>

© 1993 Seagate Technology, Inc. All rights reserved  
Publication Number: 36235-001, Rev. A  
June 1993

Seagate®, Seagate Technology®, and the Seagate logo are registered trademarks of Seagate Technology, Inc. SeaFAX™, SeaFONE™, SeaBOARD™ and SeaTDD™ are trademarks of Seagate Technology, Inc. Other product names are registered trademarks or trademarks of their owners.

Seagate reserves the right to change, without notice, product offerings or specifications. No part of this publication may be reproduced in any form without written permission from Seagate Technology, Inc.

---

---

***Read before you begin...***

**Application.** Your drive is designed for IBM AT and compatible personal computers, Sun, Macintosh and other SCSI systems.

*Turn off the system power before attempting any installation.*

**Static discharge.** Observe the following precautions:

- Keep the drive in its static-shielded bag until you are ready to complete the installation. Do not attach any cables to the drive while it is in its static-shielded bag.
- Handle the drive by its edges or frame.
- Do not touch the I/O connector pins or the circuit board.
- Before handling any components, put on a grounded wrist strap, or ground yourself frequently by touching the metal chassis of a computer that is plugged into a grounded outlet.
- Use antistatic padding on all work surfaces.
- Avoid static-inducing carpeted areas.

**Drive handling.** The drive is extremely fragile—handle it with care. Do not attach labels to any part of the drive.

**Inspection.** Once you are familiar with the handling precautions listed above, inspect the drive. If it appears to be damaged, call your distributor or dealer immediately.

**Warranty.** See your authorized Seagate® distributor or dealer.

**Maintenance and repair.** Seagate drives do not require maintenance. The head/disc assembly is sealed; if you break the seal, you void the warranty. Seagate customer service centers are the only facilities authorized to repair Seagate drives. Seagate does not sanction any third-party repair facilities.

**Shipping.** Keep your original box and packing materials for transporting or shipping your drive. The box has a *Seagate Approved Package* label. Shipping a drive in a nonapproved container voids the warranty. Call your authorized Seagate distributor to purchase additional boxes.

**Radio and television interference.** This product complies with Class B limits for radio noise emissions from computer equipment as set out in the radio interference regulations of the Canadian Department of Communications.

Le présent appareil numérique n'émet pas de bruits radioélectriques dépassant les limites applicables aux appareils numériques de Classe B prescrites dans le règlement sur le brouillage radioélectrique édicté par le Ministère des Communications du Canada.

### Sicherheitsanleitung

1. Das Gerät ist ein Einbaugerät, das für eine maximale Umgebungstemperatur von 55°C vorgesehen ist.
2. Zur Befestigung des Laufwerks werden 3 Schrauben 6-32 UNC-2A benötigt. Bei seitlicher Befestigung darf die maximale Länge der Schrauben im Chassis nicht mehr als 3,3 mm und bei Befestigung an der Unterseite nicht mehr als 5,08 mm betragen.
3. Als Versorgungsspannungen werden benötigt:  
+5V  $\pm$  5% 0,5A  
+12V  $\pm$  5% 0,5A (1,9A für ca. 30 Sek. für  $\pm$  10%)
4. Die Versorgungsspannung muß SELV entsprechen.
5. Alle Arbeiten dürfen nur von ausgebildetem Servicepersonal durchgeführt werden.
6. Der Einbau des Drives muß den Anforderungen gemäß DIN IEC 950V DC 0805/05.90 entsprechen.

### Configuring the drive

Select the appropriate drive features by installing or removing jumpers on the drive circuit board according to the instructions in Figure 1 on page 6 and Figure 2 on page 7. Refer to your host adapter documentation for terminator specifications and configuration instructions.

1. **Setting the SCSI ID.** Each device on the bus must have a unique SCSI ID. If you are installing only one drive, use SCSI ID 0 (no jumper installed). If you install a second drive, you can use any ID (SCSI ID 1 is recommended). SCSI ID 7 is usually reserved for the SCSI host adapter. To set the

SCSI ID, install jumpers on the SCSI ID jumper block as shown in Figure 1 on page 6.

- 2. Installing or removing terminating resistors.** SCSI I/O termination consists of three resistor packs, called terminators, that plug into sockets on the printed circuit board. The terminating resistors are shown in Figure 1.

If you are installing only one drive, leave the terminators installed. If you are installing multiple drives, remove the terminators from all drives except the drive connected to the end of the cable.

- 3. Installing jumpers on the terminator power source jumper block.** If you removed the terminating resistors in step 2, install a jumper on pins 2 and 4 of the terminator power source jumper block shown in Figure 1.

**Note.** Installing a jumper on pins 2 and 4 of the terminator power source jumper block does not disconnect the terminating resistors from the circuit. If your application requires no terminating resistors, you must unplug them from the drive circuit board as discussed in step 2.

To select the drive power connector as the termination power source for the resistor packs, install a jumper on pins 1 and 3 of the terminator power source jumper block.

To select the SCSI connector as the termination power source for the resistor packs, install a jumper on pins 1 and 2 of the terminator power source jumper block.

To provide terminator power to the SCSI connector from the drive power connector only, install a jumper on pins 3 and 4 of the terminator power source jumper block.

To provide terminator power to the SCSI connector and the drive terminator packs, install jumpers on pins 1 and 2 and pins 3 and 4 of the terminator power source jumper block.

**4. Installing jumpers on the active/passive termination jumper block.** If you removed the terminating resistors from the drive according to the instructions in step 2, skip this step. If you are either:

- using Fast SCSI transfer rates, or
- *not* using Fast SCSI transfer rates, and both ends of the I/O cable are terminated by resistors of equal value,

use *active* termination by installing a jumper on pins 1 and 2 of the active/passive termination jumper block, as specified in the following table.

	<b>Fast SCSI</b>	<b>SCSI</b>
<b>Termination</b>	Active	Active or passive
<b>Terminator specification</b>	110 ohms	110 ohms or 220/330 ohms
<b>Install active/passive termination jumpers</b>	Pins 1 and 2	Pins 1 and 2 or Pins 2 and 4 Pins 5 and 6

If the host adapter contains 220/330-ohm resistors that cannot be removed and replaced with 110-ohm resistors, set the drive termination power to 220/330 ohms. Remove the jumper from pins 1 and 2 and install jumpers on pins 2 and 4 and pins 5 and 6 of the active/passive termination jumper block. Then, replace the 110-ohm terminators provided with the drive with 220/330-ohm terminators.

## Attaching cables

Refer to Figure 1 on page 6 and Figure 2 on page 7 for the locations of the connectors and jumper blocks.

- 1. Turn off the system power.**
- 2. Put on a grounded wrist strap.**
- 3. Connecting a remote LED.** Remote LED pins are located on two separate jumper blocks: the options jumper block and the user-configuration jumper block. Attach a two-pin remote LED connector to either jumper block, as follows:
  - User-configuration jumper block: pins 9 and 10
  - Options jumper block: pins 7 and 8
- 4. Synchronizing drive spindles (disc arrays only).** You can synchronize the spindle motors of an array of drives by connecting a twisted pair to each drive. The maximum cable length is 6 feet (1.8 meters).

Spindle synchronization pins are located on two separate jumper blocks—the options jumper block and the user-configuration jumper block. Use either jumper block to synchronize an array of drives, as follows:

  - **User-configuration jumper block.** Use one strand of the twisted pair to connect together pin 7 of the user-configuration jumper block of each drive. Use the other strand to connect together pin 8 of the user-configuration jumper block of each drive.
  - **Options jumper block.** Use one strand of the twisted pair to connect together pin 5 of the options jumper block of each drive. Use the other strand to connect together pin 6 of the options jumper block of each drive.
- 5. Attaching the power cable.** Attach a system power cable to the drive power connector.

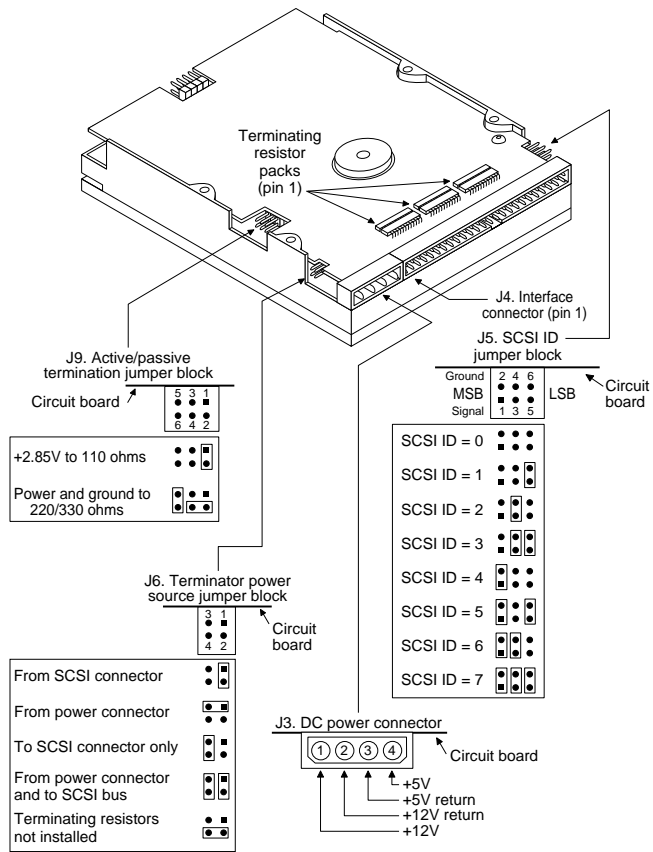

**Figure 1. Back view**



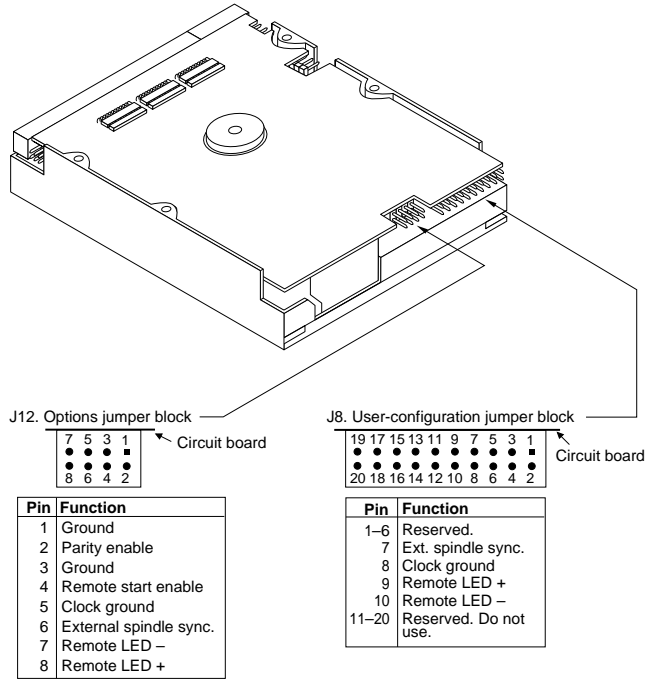

Figure 2. Front view

- 6. Attaching the 50-pin SCSI interface cable.** Attach one end of the cable to the drive interface connector and the other end to the interface connector on the host system motherboard or the host adapter. If you are installing multiple drives, use a daisy-chain cable.

Verify that pin 1 of the interface cable is matched to pin 1 of the interface connector on the drive and on the host. Pin 1 is usually denoted by a stripe on the side of the ribbon cable. The location of pin 1 of the drive interface connector is shown in Figure 1 on page 6.

## Mounting the drive

You can mount the drive in any orientation. Follow the guidelines below for either bottom mounting or side mounting. Figure 3 shows the recommended mounting orientations and the optimum placement of mounting screws.

**Caution.** If you use a screw that is too long, you could damage the drive. Do not insert the bottom mounting screws more than 0.20 inches (6 turns) into the drive frame. Do not insert the side mounting screws more than 0.13 inches (4 turns) into the drive frame.

**Bottom mounting holes.** Use 6-32 UNC-2A screws in three of the four available bottom mounting holes as shown in Figure 3.

**Side mounting holes.** Use 6-32 UNC-2A screws in three of the six available side mounting holes as shown in Figure 3.

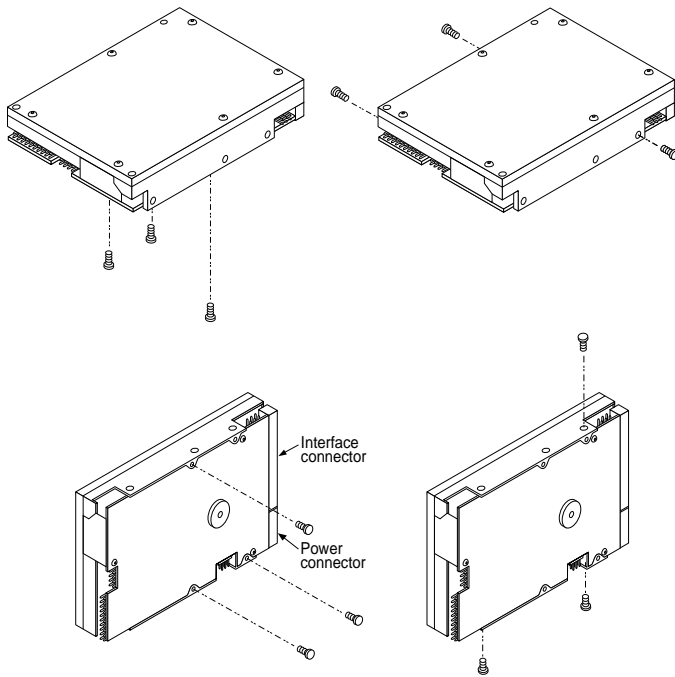

**Figure 3. Recommended mounting orientations**

## CMOS setup for AT systems

When you start up your drive for the first time, enter the CMOS SETUP routine. This routine enables you to define a new drive in the system BIOS. However, because the SCSI host adapter BIOS handles all I/O procedures, you should not attempt to define the drive type in the system BIOS. Instead, set the CMOS, or system setup, to drive type zero, or the *no hard drive installed* option.

**Note.** If you are installing your drive in an AT system and a hard drive is not presently installed, the CMOS drive type is already set to zero or the *no hard drive installed* option.

## Physical geometry for non-DOS operating systems

When installing the drive in non-DOS operating systems, use the following information to configure your host system:

	ST3390N	ST3655N
Data cylinders	2,676	2,676
Spare cylinders	2	2
Read/write heads	3	5
Total sectors	672,480	1,065,036
Spindle speed (RPM)	4,500	4,500

## Low-level formatting

Your drive was low-level formatted at the factory to 512 bytes per sector. In most applications, you do not have to format it again. However, you may need to low-level format the drive to make it compatible with your SCSI host adapter or to change the interleave. See your host adapter manual for details.

If you choose to low-level format your drive, use the DOS DEBUG utility. The most common DEBUG low-level formatting command is `g=c800:5`. Verify the BIOS address (c800) and the offset (5) with your host adapter manual.

**Caution.** If you format a drive at any level, you erase all your data. Back up the drive first. Seagate assumes no liability if you destroy your data.

## Partitioning

If you are using a version of DOS before Version 4.0, the capacity of your drive is effectively limited to roughly 33 Mbytes. Therefore, you have to divide higher-capacity drives into individual logical drives, called partitions. Each partition is assigned a different letter, for example, C: and D: for a drive with two partitions.

Regardless of the DOS version you are using, you need to prepare the drive by writing partitioning information on it. After you have configured the drive and defined it in the CMOS, boot the system from the diskette drive with a bootable DOS diskette. Then, run the FDISK utility (DOS Version 3.3 or higher) to partition the drive. Make sure the primary partition is active. See your DOS manual for instructions.

**Caution.** If you partition or format a drive at any level, you erase all your data. Back up the drive first. Seagate assumes no liability for lost user data.

Many Unix-based operating systems allow you to partition the drive for DOS applications. See your system manual.

## High-level formatting

High-level formatting verifies the information written by the low-level format and establishes drive access information used by the operating system. High-level formatting creates the File Allocation Table used by DOS to access the drive.

To high-level format the drive, perform the following operations:

1. Use the FORMAT utility to high-level format the drive. Refer to your DOS manual for the FORMAT command options.
2. If you are formatting the boot drive, copy the necessary system files to the drive.

In Unix, high-level formatting creates the i-node used for file access information. Drive formatting and partitioning are both performed by a single operating system utility. Refer to your Unix system documentation for instructions.

## Troubleshooting

Before you begin troubleshooting, read all the suggestions discussed in the following list; they resolve the majority of installation problems.

**Warning.** Always turn off the system before changing jumpers or unplugging cables and cards.

- **Verify compatibility.** Reread the documentation for the host adapter and the drive to confirm that these components are appropriately matched to each other and to your computer.
- **Verify your configuration.** Using the instructions in the drive and host adapter installation guides, make sure all jumpers are installed (or removed) to suit your application.
- **Check the power supply specifications.** The output of your power supply may not meet the requirements of the new devices you are installing. If you are not sure whether your power supply meets your needs, consult your dealer.
- **Check all cards.** Make sure all cards are seated in their slots on the motherboard; then, secure them with mounting screws.
- **Verify the CMOS drive type.** The CMOS drive type must be set to zero in AT systems.
- **Check all cables.** Make sure all cables are securely connected. Ribbon cables are especially fragile. Make sure they

are not crimped or damaged in any way. Keeping extra cables on hand for troubleshooting saves time and frustration.

For each ribbon cable, verify that pin 1 of the cable is matched to pin 1 of the connector. Pin 1 is usually denoted by a stripe on the side of the ribbon cable.

**Caution.** Do not randomly reverse-plug the cables. This can damage some systems.

When connecting the diskette drive, make sure you use a control cable for a diskette drive and not a hard drive. Unlike the hard drive cable, the diskette drive control cable has seven lines split and twisted.

- **Check the BIOS memory address.** Make sure the address you typed during DEBUG agrees with the address you selected with the host adapter BIOS address selection jumper.

Assuming you have configured the host adapter correctly and a memory conflict exists, the problem might be that the host adapter is trying to use the same BIOS memory address as another peripheral on your system. The easiest solution is to try all possible BIOS addresses.

If the memory conflict persists, isolate the conflict by disconnecting all other peripherals (except the video card) and installing the drive and the host adapter separately from the other components. Then, install the other peripherals one at a time until the conflict resurfaces.

Once you have isolated the source of the address conflict, you can resolve the conflict by either changing the BIOS address of the peripheral that appears to cause the conflict, or by changing the BIOS address of the host adapter.

- **Check for viruses.** Before you load new software, scan the diskette for viruses.

Before continuing, carefully read the preceding checklist. You need to refer to the introductory material to effectively use the following information.

**The system does not recognize the presence of the drive or system error message, “No Drives Found,” appears.**

- Check all cables.
- Check all cards.
- Check the BIOS memory address.
- Check the drive type. In AT systems, the drive type must be set to zero.
- Check the drive and host adapter terminating resistors. See “Configuring the drive” on page 2 and refer to your host adapter documentation.
- Check the terminator power source jumper settings and the active/passive termination jumper settings described on pages 3 and 4 respectively.
- Check the power supply specifications.
- Reboot and make sure the drive spins up. (It may be difficult to hear the drive spin up.) If the drive does not spin up, check all drive cables.
- If you tried to install more than two hard drives or two diskette drives, you may have installed more drives than your host adapter can support. Check your host adapter documentation for details.

**System error message, “Drive not Ready,” appears.**

- Check all cables. For each ribbon cable, verify that pin 1 of the cable is matched to pin 1 of the connector. Pin 1 is usually denoted by a stripe on the side of the ribbon cable.
- Check the power supply specifications.



- Turn off the system and wait 20 seconds. Turn it back on and make sure the drive spins up. If the drive does not spin up, check the drive power cable.

**The screen stays blank when you power up the system.**

- Make sure the monitor is plugged in and turned on.
- Check all cards. Make sure the video card is seated in its slot and secured with mounting screws.
- Check all cables. Make sure the video card cables are securely attached.
- While the system is turned off, remove the drive host adapter. If the screen turns on after you reboot, the host adapter may be incompatible or defective. See your dealer.

**The system hangs in FDISK or fails to create or save the partition record.**

- Check all cables.
- The DOS utilities diskette may be corrupted. Try your backup DOS diskette.
- If your version of DOS is 4.0 or older, make the drive partitions smaller.
- Check for media defects at the beginning of the drive. Use a third-party surface scan utility.

**The FDISK error message, "No Fixed Disk Present," appears.**

- Check all cables.
- Check the power supply specifications.
- Make sure the drive spins up when you turn on the system.
- Check the drive type. In AT systems, the drive type must be set to zero.
- Check for I/O address conflicts.

**During the DOS high-level format, the drive keeps retrying hard errors and reporting the following message. "Attempting to recover allocation units. . ."**

- This is normal with DOS Version 4.0 or later.

**DOS messages, "Disk Boot Failure," "Non-System Disk," or "No ROM Basic - SYSTEM HALTED," appear.**

- Open the floppy door.
- Check all cables.
- Use the same version of DOS throughout your system.
- Reinstall the DOS system files using the DOS SYS utility.
- Make sure the primary partition is active in FDISK.
- Check for viruses.

### **Technical support services**

Always consult your system dealer first for technical support. Dealers are generally more familiar with unique system configurations.

Technical support is available for all Seagate products by calling the SeaFAX™, Seagate Technical Support FAX, SeaFONE™, SeaBOARD™ and SeaTDD™ services.

#### **SeaFAX. 408/438-2620**

You can use a touch-tone telephone to access Seagate's automated FAX system to receive technical support information by return FAX. This service is available 24 hours daily.

#### **Seagate Technical Support FAX. 408/438-8137**

You can FAX questions or comments to technical support specialists 24 hours daily. Responses are sent between 8:00 A.M. and 5:00 P.M. (Pacific time), Monday through Friday.

**SeaFONE. 408/438-8222**

You can talk to a technical support specialist between 8:00 A.M. and 5:00 P.M. (Pacific time), Monday through Friday. SeaFONE provides recorded technical information on selected Seagate products while you are on hold. You can access the recordings 24 hours daily. Before calling, note your system configuration and drive model number (STxxxx).

**SeaBOARD**

Using a modem, you can:

- Access documentation, drive specifications and jumper settings for Seagate's entire product line.
- Download software for installing and analyzing your drive.
- Request a return phone call from the technical support staff.

SeaBoard is available 24 hours daily. It supports communications up to 9600 baud. Set your communications software to eight data bits, no parity, and one stop bit (8-N-1). SeaBOARD phone numbers are listed in the following table.

<b>Location</b>	<b>Modem number</b>
United States	408-438-8771
England	44-62-847-8011
France	33-1-40 67 10 34
Germany	49-89-140-9331
Singapore	65-292-6973
Australia	61-2-756-2359

**SeaTDD. 408/438-5382**

Using a TDD (telecommunications device for the deaf), you can send questions or comments 24 hours daily and exchange messages with a technical support specialist between 8:00 A.M. and 5:00 P.M. (Pacific time), Monday through Friday.



**Seagate Technology, Inc.**  
**920 Disc Drive, Scotts Valley, CA 95066, USA**  
*Publication Number: 36235-001, Rev. A, Printed in USA*