

NPB-MDM Modem Card

INSTALLATION INSTRUCTIONS

GENERAL



CAUTION

This modem may require testing and certification in some European and Asian countries prior to connecting to the Public Switched Telephone Network. Refer to the particular country's telephone authorities for further information.

This document covers the mounting and wiring of the NPB-MDM Modem Card in a Honeywell WEB-201 Controller. For related WEB-IO mounting and wiring details, refer to the WEB-201 Controller Installation Instructions, form no. 95-7722.

The Honeywell NPB-MDM Modem Card uses a 56kbps auto-dial, auto-answer modem with one RJ-11 connector for the phone line. The NPB-MDM Modem Card must be installed in Option Slot 1 only, where it operates as COM1. This *disables* the RS-232 base serial port (DB-9 connector) on the WEB-201 Controller. Only one NPB-MDM Modem Card is supported in a WEB-201 Controller. Refer to Fig. 2 for location of option slots.

SAFETY INSTRUCTIONS

NOTES REGARDING DEVICE DESCRIPTION

These instructions include indications for use and mounting of the device. In case of questions that cannot be answered with these instructions, please consult the product supplier or manufacturer. It is the responsibility of the equipment installer to ensure that all federal, state and local codes are followed.

SAFETY INSTRUCTIONS

- Keep these Installation Instructions for industrial safety and the prevention of accidents.
- Only qualified personnel shall do mounting and installation work with these devices, see section titled "Qualified Personnel".
- The information in these instructions must be read and understood by every person using this device.

QUALIFIED PERSONNEL

Qualified personnel in the sense of these instructions are persons who are well versed in the use and installation of such devices and whose professional qualifications meet the requirements of their work.

This includes, for example:

- Qualifications to connect the device according to applicable specifications and regulations, and qualifications to put this device into operation, to power it down, or to activate it by respecting the internal directions.
- Knowledge of safety rules.
- Knowledge about application and use of the device within the equipment system.

BEFORE INSTALLATION

1. Unpack the NPB-MDM Modem Card.
2. Check the equipment and report any damage to a Honeywell representative.
3. Read all of these instructions and ensure they are understood.

Included in this Package

Included in this package are the following items:

- One NPB-MDM Modem Card, along with connector and end plate.
- INSTALLATION INSTRUCTIONS form no. 95-7730.

Materials and Tools Required

The following tools and supplies may be required for installation:

- #2 Phillips screwdriver: used to install the NPB-MDM Modem Card.



MOUNTING

⚠ WARNING

Power to the WEB-201 Controller must be OFF when installing or removing option cards, or damage will occur! Also, be very careful to plug any option card into its connector properly (pins aligned).

The NPB-MDM Modem Card is for Option Slot 1 only.

NOTE: If another option card already exists in Slot 1, it must be moved to Option Slot 2. Refer to GENERAL and SERIAL SHELL NOTES sections.

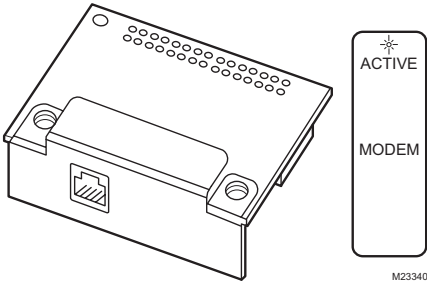

Fig. 1. NPB-MDM Modem Card.

1. **Power down** the WEB-201 Controller (see WARNING in MOUNTING section).
2. Remove the WEB-201 Controller cover.
 - a. Press in the four tabs on both ends of the unit, and lift the cover off.

NOTE: If accessory modules are plugged into the WEB-201 Controller, slide them away from the unit to get to the cover tabs.

3. Remove the battery and bracket assembly by taking out the four screws holding it in place, setting the screws aside for later.
 - a. Unplug the battery from the connector on the WEB-201 Controller:

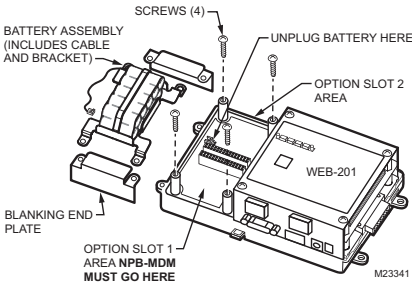

Fig. 2. Removal of screws and battery assembly.

4. Remove the Slot 1 blanking end plate.
 - a. Retain the blanking end plate in case the NPB-MDM Modem Card must be removed at a later date.
5. Carefully insert the pins of the NPB-MDM Modem Card into the socket of slot 1 option connectors. The mounting holes on the option board should line up with the standoffs on the base board. If they do not, the connector is not properly aligned.
 - a. Press until the NPB-MDM Modem Card is completely seated.
6. Place the custom end plate that came with the NPB-MDM Modem Card over its connector. (See Fig. 3).
7. Plug the battery cable into the battery connector on the WEB-201 Controller. (See Fig. 3).

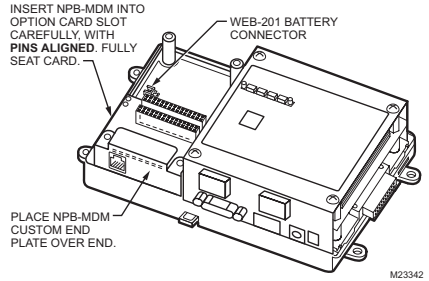

Fig. 3. Top view, NPB-MDM end plate insertion.

8. Set the battery and bracket assembly back over the option card slots, with the mounting holes aligned with the standoffs.
9. Place the four screws through the battery bracket, end plate, and into the standoffs on the WEB-201 Controller base board. Hand tighten these screws.

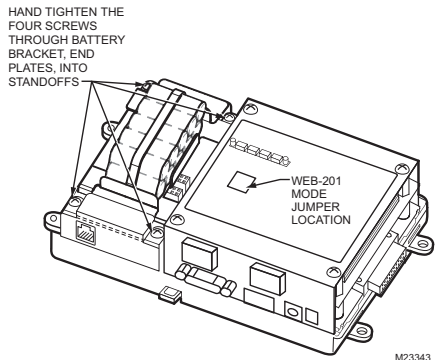

Fig. 4. Battery bracket screw re-fastening.

10. Replace the WEB-201 Controller cover.
 - a. If accessory modules were unplugged, plug them back into the WEB-201 Controller as before and secure.

WIRING

Connect a standard RJ-11 telephone cable to the connector on the NPB-MDM Modem Card and the other end to the working PSTN (dialup) telephone receptacle.

LEDS

A single LED is visible on the top of the NPB-MDM Modem Card (cover must be removed from the WEB-201 Controller). This LED is shown on the top label of the NPB-MDM (refer to Fig. 1) and operates as follows:

- ACTIVE (green) — When lit, it indicates that the modem is connected to another modem (a carrier is detected). In this case, the WEB-201 serial port LEDs (on its lower base board) should indicate transmit and receive activity.

SERIAL SHELL NOTES

If an NPB-MDM Modem Card is installed and the WEB-201 Controller's "Mode Jumper" (Refer to Fig. 4) is put in "Serial Shell" position, the WEB-201 base RS-232 port becomes active immediately following a reboot. This allows an RS-232 connection to the "Serial Shell" for debugging purposes. The NPB-MDM Modem Card is inoperative during this period.

To re-enable the modem, the Mode Jumper must be put back in the NORMAL position, and then reboot the WEB-201 Controller.

Automation and Control Solutions

Honeywell International Inc.
1985 Douglas Drive North
Golden Valley, MN 55422
customer.honeywell.com

Honeywell Limited-Honeywell Limitée
35 Dynamic Drive
Scarborough, Ontario M1V 4Z9

® U.S. Registered Trademark
© 2006 Honeywell International Inc.
95-7730 J.I. 04-06



Printed in U.S.A. on recycled
paper containing at least 10%
post-consumer paper fibers.

Honeywell