

PLAYSTATION® 3

Wireless Headset

User's Guide

SCEH-00075

SCEH-00087

Before using this product, carefully read the supplied documentation.

Contents

1. Warnings

- 1.1 Recycling instructions for customers in Europe
- 1.2 Lithium-ion battery in Wireless Headset

2. Before use

- 2.1 Precautions
- 2.2 Use and handling

3. Part names

4. Charging your headset

- 4.1 Charging time
- 4.2 Using the charging cradle
- 4.3 Charging without the cradle

5. Pairing your headset

- 5.1 Pairing with the PS3™ system: automatic mode
- 5.2 Pairing with the PS3™ system: Bluetooth® discovery mode
- 5.3 Pairing with a mobile phone

6. Turning your headset on and off

- 6.1 To turn on your headset
- 6.2 To turn off your headset

7. Connecting your headset to Bluetooth® devices

8. Testing and configuring the headset

9. Wearing your headset

- 9.1 Adjusting the fit
- 9.2 Changing the ear clip

10. Headset features for your PS3™ system

- 10.1 User action indicator
- 10.2 Notifications
- 10.3 HQ mode
- 10.4 Desktop Mic mode

11. Using your headset with a mobile phone

12. Headset controls

- 12.1 When connected to a PS3™ system
- 12.2 When connected to a mobile phone

13. Headset indicators

- 13.1 General indicator lights
- 13.2 Indicator lights when connected to a mobile phone
- 13.3 Headset tones

14. Troubleshooting

15. Product specifications

16. Limited warranty

1. Warnings

- To reduce the risk of electric shock, explosion or fire, use only the supplied charging cradle or the supplied USB cable to charge the product. Do not use the charging cradle with other products or for any other purpose.
- Charge the headset according to the supplied instructions.

1.1 Recycling instructions for customers in Europe

Where you see either symbol on any of our electrical products, batteries or packaging, it indicates that the relevant electrical product or battery should not be disposed of as general household waste in Europe. To ensure the correct waste treatment of the product and battery, please dispose of them in accordance with any applicable local laws or requirements for disposal of electrical equipment/batteries. In so doing, you will help to conserve natural resources and improve standards of environmental protection in treatment and disposal of electrical waste

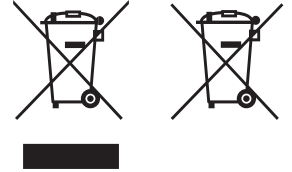

1.2 Lithium-ion battery in Wireless Headset

The Lithium-ion polymer battery included in this product is permanently built-in for safety, performance or data integrity reasons. The battery should not need to be replaced during the lifetime of the product and should only be removed by skilled service personnel. To ensure the correct waste treatment of the battery, please dispose of this product as electrical waste.

2. Before use

This guide contains instructions for setting up and using your Wireless Headset with your PS3™ system as well as with other Bluetooth® compatible mobile phones and devices.

2.1 Precautions

Before using this product, carefully read this manual and retain it for future reference. Also refer to the instructions for your PLAYSTATION®3 system for further precautions and information.

2.2 Use and handling

- Stop using this product immediately if it causes discomfort or pain.
- Do not expose the product to high temperatures, high humidity or direct sunlight.
- Do not allow the product to come into contact with liquids.
- Do not put heavy objects on the product.
- Do not throw or drop this product, or physically damage it in any way.
- Do not touch or insert foreign objects into the connectors of this product.
- Do not attempt to disassemble or modify this product.
- Do not twist the supplied USB cable or pull it forcibly.
- When using this product, it is recommended that you limit volume to help avoid harm to your ears and danger resulting from being unable to hear what is going on around you.
- Do not place any rubber or vinyl materials on the product exterior for an extended period of time.
- Use a soft, dry cloth to clean the product. Do not use solvents or other chemicals. Do not wipe with a chemically-treated cleaning cloth.
- Small parts. Not suitable for children under six years.
- Comply with laws regarding use of a mobile phone and headset while driving. If you use the headset while driving, make sure that your attention and focus remain on driving safely.
- Observe all signs and instructions that require an electrical device or radio product to be switched off in designated areas, such as petrol/refuelling stations, hospitals, blasting areas, potentially explosive atmospheres or aircraft.

PLEASE NOTE: the information in this manual was correct at the time of publication, but some minor changes may have been made late in the product's development. All screenshots for this manual have been taken from the English version of this product.

3. Part names

1. Power button
2. Volume + button
3. Volume – button
4. Mic muting button
5. Mic muting indicator
6. Power indicator
7. Ear clip
8. Charging cradle

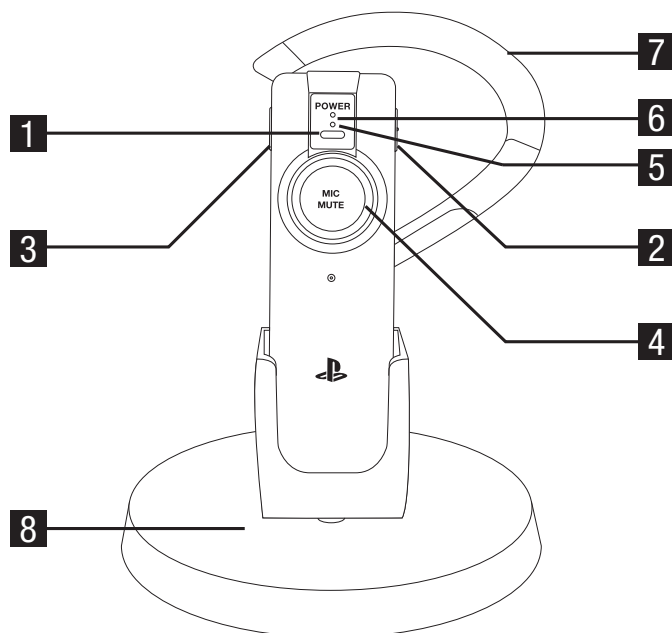

4. Charging your headset

Your headset performs best when fully charged. You can charge the headset by using the charging cradle or directly via a USB cable.

Warning

Do not wear your headset while it is connected to the charging cradle or a USB cable.

4.1 Charging time

3 hours	Approximate time for full charge using charging cradle or USB
1 hour	Minimum charge before first use

Hint

To check the headset's battery level, you must pair it using automatic mode and not Bluetooth® discovery mode. Further information on [pairing your headset](#) and [viewing the battery level](#) on your monitor/TV can be found later in this manual.

4.2 Using the charging cradle

For convenience, you can connect the charging cradle to a USB device to allow easy access to the headset.

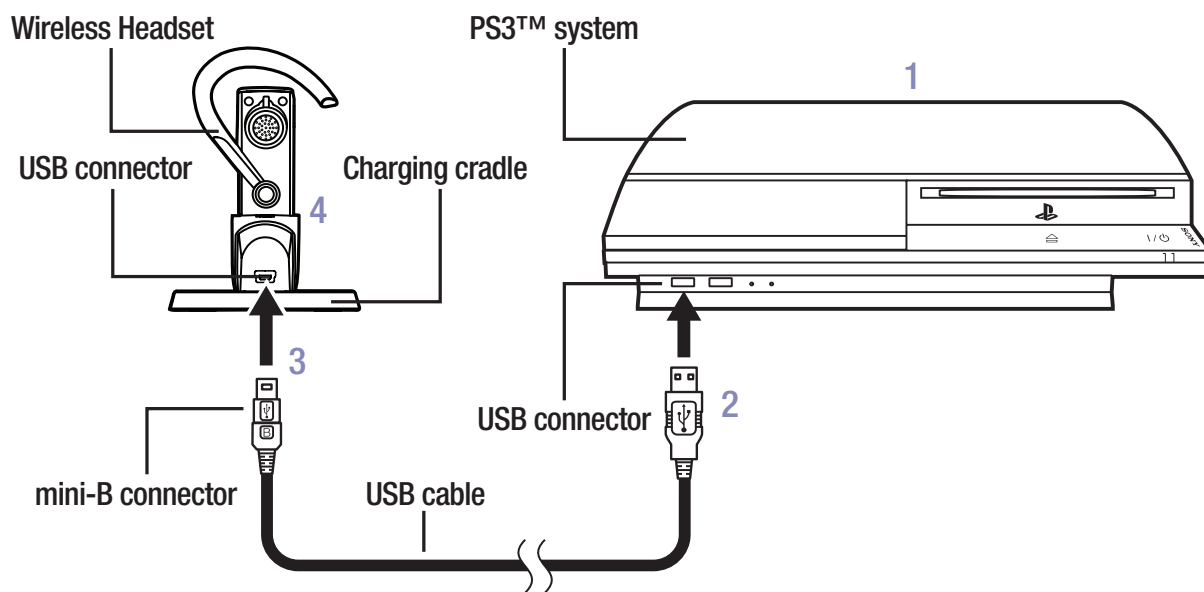

- 1 Check that the device the charging cradle is to be connected to is turned on.
- 2 Insert the USB connector of the supplied USB cable into an available USB connector.
- 3 Insert the mini-B connector of the USB cable into the USB connector on the charging cradle.
- 4 Place the headset into the charging cradle.

When power is first applied to the headset, the mic muting indicator lights up solid red for two seconds and then flashes on and off every three seconds until the headset is fully charged.

4.3 Charging without the cradle

You can charge the headset directly from a USB device.

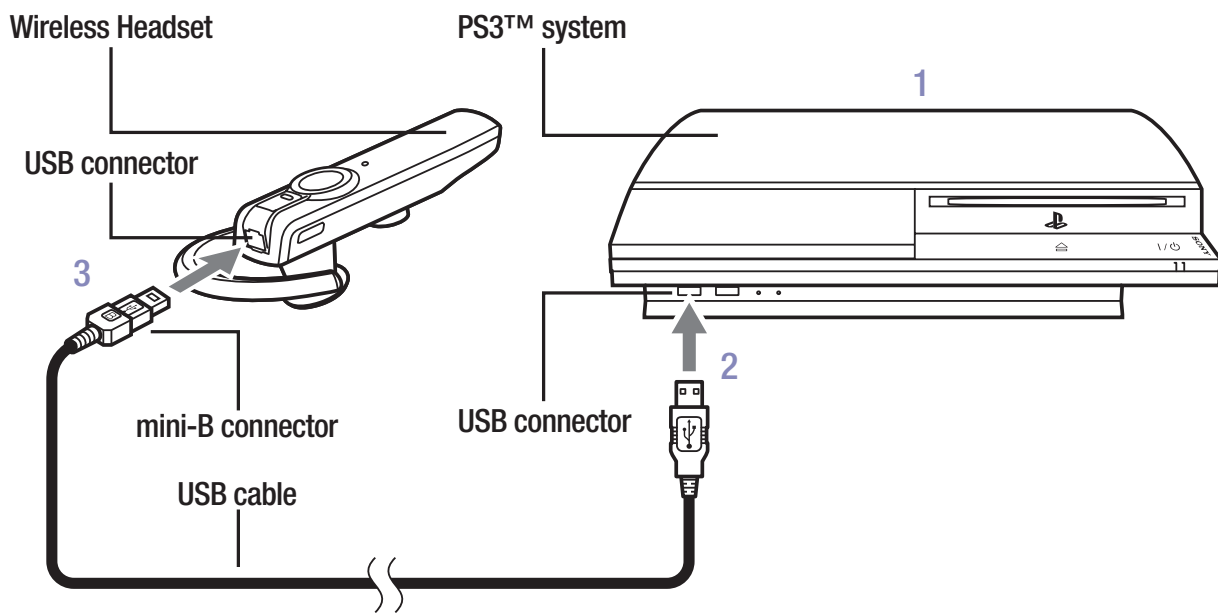

- 1 Check that the device the headset is to be connected to is turned on.
- 2 Insert the USB connector of the supplied USB cable into an available USB connector.
- 3 Insert the mini-B connector of the USB cable into the headset USB connector.

When power is first applied to the headset, the mic muting indicator lights up solid red for two seconds and then flashes on and off until the headset is fully charged.

5. Pairing your headset

Before you can use the Wireless Headset with any device, such as a PS3™ system or a mobile phone, the headset must be paired with the desired device.

You can pair your headset in either of two ways:

- Automatic mode (using the supplied USB cable) – the headset includes a variety of advanced features for the PS3™ system which can be enabled by pairing (registering) the headset and the PS3™ system using automatic mode. Using automatic mode, you can pair the headset with any PS3™ system, but only the most recently paired PS3™ system will be saved in the headset's list of paired devices. For more information, see [“7. Connecting your headset to Bluetooth® devices.”](#)
- Bluetooth® discovery mode – set up the headset as a standard Wireless Headset. Using Bluetooth® discovery mode, you can pair the headset with many other Bluetooth® devices. The eight most recently paired devices are saved in the headset's list of paired devices. For more information, see [“7. Connecting your headset to Bluetooth® devices.”](#)

Hints

The headset's advanced features for the PS3™ system are available only when you use the automatic mode to pair the headset with the PS3™ system.

To access the advanced features, the system software in use on the PS3™ system must be version 2.50 (or later).

5.1 Pairing with the PS3™ system: automatic mode

You must use the USB cable to pair your headset using automatic mode.

- 1 Check that the PS3™ system is turned on.
- 2 Check that the PS3™ system software is version 2.50 or later. If you have an earlier version, you need to update the system software before you can use automatic mode for pairing.
- 3 Insert the mini-B connector of the supplied USB cable into the USB connector on your headset. Insert the other end of the cable into a USB connector on the PS3™ system.

The power indicator on the headset lights up in solid green for two seconds to indicate that the headset and the PS3™ system have been paired.

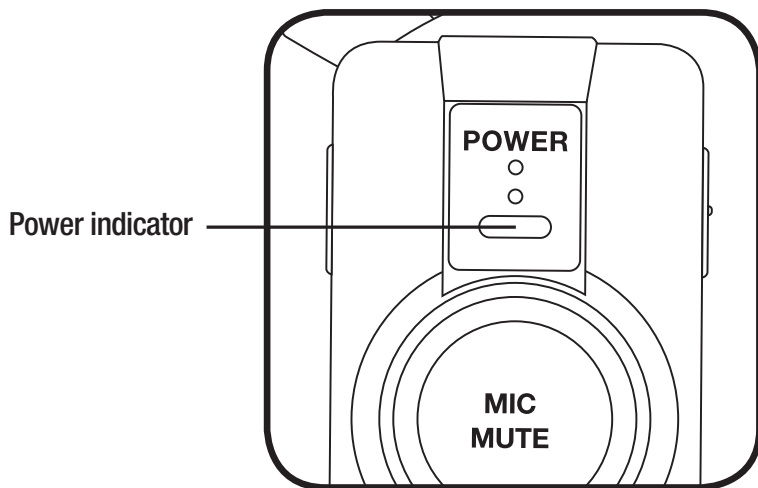

Hint

When automatic mode is used to pair your headset, HQ mode is initially turned on.

See the “10. Headset features for your PS3™ system” section later in this manual for more information.

5.2 Pairing with the PS3™ system: Bluetooth® discovery mode

- 1 Check that the PS3™ system is turned on.
- 2 Press and hold the power button on the headset until the power and mic muting indicators flash alternately in green and red, indicating that the headset is in Bluetooth® discovery mode.
- 3 On your PS3™ system’s Home Menu, go to [Settings], then [Accessory Settings] and select [Manage Bluetooth® Devices].
- 4 Select [Yes] to pair (register) the headset with the PS3™ system.
- 5 Select [Start Scanning].

The PS3™ system scans for the headset and a list of all Bluetooth® devices within range will be displayed.

- 6 Select [Wireless Headset]. When prompted for a pass key, enter “0000”.

Your headset is now paired with the PS3™ system.

5.3 Pairing with a mobile phone

You can use your headset with any Bluetooth®-enabled mobile phone, although advanced features such as three way calling are not available with this headset.

Hint

If you use automatic mode to pair your headset with your PS3™ system, and also pair your headset with a mobile phone, the headset gives priority to the PS3™ system when both are in range. The headset will connect to your PS3™ system, not the mobile phone.

- 1 Check that the mobile phone is turned on.
- 2 Press and hold the power button on the headset until the power and mic muting indicators flash alternately in green and red, indicating that the headset is in Bluetooth® discovery mode.
- 3 Turn on the Bluetooth® feature on your mobile phone to enable it to scan for the headset. See your mobile phone's instruction manual for further information on activating the phone's Bluetooth® functionality.
- 4 From the list of devices, select [Wireless Headset]. When prompted for a pass key, enter "0000".

Your headset is now paired with the mobile phone.

6. Turning your headset on and off

6.1 To turn on your headset

Press and hold the power button for approximately three seconds until a melody plays and the power indicator lights solid green for two seconds. This indicates that the headset is on.

For more detailed information regarding how the headset connects to devices when you turn it on, see the "7. Connecting your headset to Bluetooth® devices" section of this manual.

6.2 To turn off your headset

Press and hold the power button for at least five seconds until a melody plays and the power indicator flashes green. This indicates that the headset is turning off. When the indicator is no longer lit, the headset is off.

7. Connecting your headset to Bluetooth® devices

When you turn on your Wireless Headset, it automatically tries to connect to paired devices within range. If you have paired the headset with more than one device, the headset uses the following priority to determine which device it will connect to:

- 1 A PS3™ system that was paired using automatic mode. If the headset finds the PS3™ system within five seconds, it will stop searching for other devices and connect to the PS3™ system. Further information on pairing the PS3™ system using automatic mode can be found earlier in this manual.
- 2 The most recent device (PS3™ system or other Bluetooth®-enabled device) that the headset was connected to with which it was paired using Bluetooth® discovery mode. If the headset finds the device within five seconds, the headset will stop searching for other devices and connect to the device. If the device is not found, the headset will commence searching (page scan) mode.
- 3 To connect the headset with the next most recent device it was connected to, short press the power button, If that device is found within five seconds, the headset stops searching for devices and makes the connection. If this device is not found, the headset goes into searching (page scan) mode. The user can short press the power button every five seconds until it connects to a device from the list of eight most recently connected devices.

If the headset cannot find any devices to connect to within five minutes after it is turned on, it will turn off automatically.

8. Testing and configuring the headset

After you have connected the headset to the PS3™ system, you can verify that the PS3™ system is receiving voice input from the headset and that the headset is correctly playing output.

To test and configure your headset:

On your PS3™ system's Home Menu, go to [Settings], then [Accessory Settings] and select [Audio Device Settings].

After you pair a Bluetooth® device with the PS3™ system, the Bluetooth® device becomes the default for both input and output audio. If the headset is working correctly, you can hear your voice loop back in the headset. The audio input bar indicates your voice level.

9. Wearing your headset

Warning

Do not wear your headset while it is connected to the charging cradle or a USB cable.

9.1 Adjusting the fit

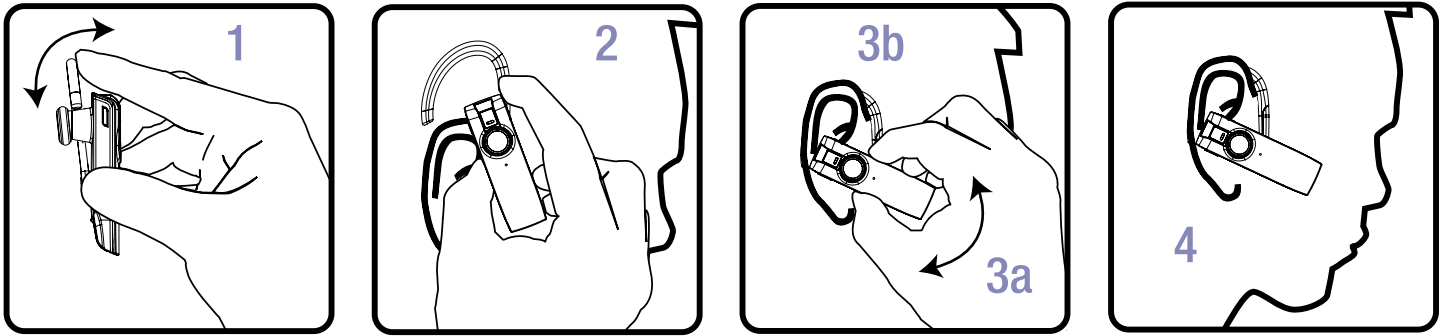

- 1 Gently push open the ear clip.
- 2 While holding the ear clip open, slide it behind your ear.

Hint

The headset comes ready to wear on your right ear. To wear it on your left ear, change the ear clip position as explained below in “9.2 Changing the ear clip”.

- 3 Adjust the headset (3a) until it fits comfortably on your ear. For maximum comfort, you can change the shape of the ear clip (3b).

Hint

An additional earpiece ring is included – use the one that feels most comfortable.

- 4 For optimal voice clarity, point the boom toward the corner of your mouth.

9.2 Changing the ear clip

- 1 Gently pull the bottom of the ear clip off the hinge pin.
- 2 Flip the clip over so that it is symmetrically opposite from its original position.
- 3 Hook the bottom of the clip onto the hinge pin.

10. Headset features for your PS3™ system

When you use automatic mode to pair your Wireless Headset with your PS3™ system, the following advanced features are enabled:

- User Action Indicators on your monitor/TV
- Notifications of headset status on your monitor/TV
- High-Quality (HQ) Mode
- Desktop Mic Mode
- Low battery warning

10.1 User action indicator

Any time you connect or pair the headset, or press any of the headset's buttons, a User Action Indicator (UAI), containing both text and icons, is displayed on your monitor/TV for two seconds. UAIs may look similar to the following:

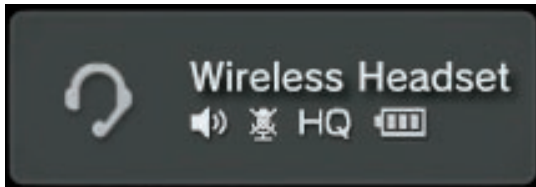

Speaker volume

The left-most icon indicates the speaker volume by showing zero to three waves. An "X" over the speaker icon indicates a minimal volume (effectively muted); three waves indicates the maximum volume.

Microphone status

The microphone icon indicates whether mic muting is on (an "X" is over the microphone icon) or off (no microphone icon).

High Quality (HQ) mode status

When High Quality mode is on, HQ is displayed in the UAI. When High Quality mode is off, HQ is not displayed in the UAI.

Battery level

The right-most icon indicates how much charge remains in the headset.

Blinking:	Charging
3 cells:	70%-100%
2 cells:	30%-69%
1 cell:	10%-29%
No cells:	Less than 10%

Hint

The battery level indication is available only if you used automatic mode to pair your headset and PS3 system. If you used Bluetooth® Discovery mode, the headset's red mic muting indicator will flash every 10 seconds when the battery is low.

10.2 Notifications

In certain situations, such as headset disconnection, low battery and connection errors, the headset will display text notifications on your monitor/TV. These messages are for information only, and do not require any action. The messages automatically disappear after five seconds. They may look similar to the following:

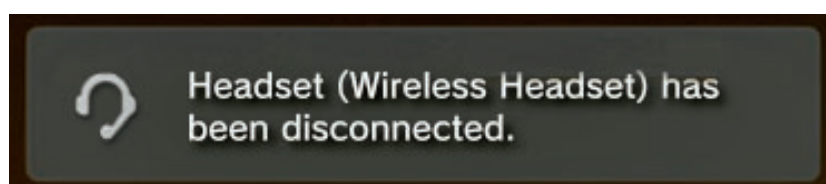

10.3 HQ mode

The headset's High Quality (HQ) mode enables wide-band wireless voice communication with the PS3™ system. It uses the headset's dual-microphone design to enable proprietary PS3™ system-based noise cancelling, and provides better radio frequency interference rejection when it is turned on than when it is off.

By default, HQ mode is on when you first pair your headset and PS3™ system.

HQ mode and noise cancellation features are only available for the PS3™ system, not with other Bluetooth®-enabled devices or mobile phones.

To turn HQ mode on or off

- 1 On your PS3™ system's Home Menu, go to [Settings], then [Accessory Settings] and select [Manage Bluetooth® Devices].
- 2 Select the headset from the list of registered devices, press the  button, and then select [Information] from the options menu.
- 3 Access High Quality (HQ) Mode.
- 4 Select On or Off.

10.4 Desktop Mic mode

If your headset charge runs low, you can use the headset as a desktop microphone (or 'far-field' microphone) while charging it.

To enter Desktop Mic mode

- 1 Check that the PS3™ system is turned on.
- 2 Insert the USB connector of the supplied USB cable into a USB connector on the PS3™ system.

Hint

You can use any powered port of a USB certified device, on any PC, so long as it is within Bluetooth® range of the PS3™ system.

- 3 Insert the mini-B connector of the USB cable into the charging cradle.
- 4 Place the headset into the charging cradle. The headset turns off and starts charging.
- 5 To reconnect the headset to the PS3™ system and use it in Desktop Mic mode, turn on the headset by pressing its power button for three seconds.

11. Using your headset with a mobile phone

When used with a mobile phone, your Wireless Headset functions similarly to a standard Bluetooth®-enabled headset. You can answer, cancel and end calls; transfer from the headset to the phone, and redial the most recent number you called. For more information, see the “[12. Headset controls](#)” and “[13. Headset indicators](#)” sections of this manual.

12. Headset controls

12.1 When connected to a PS3™ system

Turn on the headset	Press and hold the power button for about three seconds
Turn off the headset	Press and hold the power button for at least five seconds
Mute the microphone (when in an active voice state)	Press the mic muting button
Cancel microphone muting	Press the mic muting button
Adjust the volume	Press the volume + or volume – button. Each press adjusts the volume by one level A long press adjusts the volume by two levels A very long press adjusts the volume to maximum (with the volume + button) or minimum (with the volume – button)

12.2 When connected to a mobile phone

Turn on the headset	Press and hold the power button for about three seconds
Turn off the headset	Press and hold the power button for at least five seconds
Mute the microphone (when in an active call)	Press the mic muting button
Cancel microphone muting	Press the mic muting button
Adjust the volume	Press the volume + or volume – button. Each press adjusts the volume by one level A long press adjusts the volume by two levels A very long press adjusts the volume to maximum (with the volume + button) or minimum (with the volume – button)
Answer a call	Briefly press the power button
Reject a call	Press and hold the power button for two seconds
End a call or cancel an outgoing call	Briefly press the power button
Transfer a call from headset to phone	Press and hold the power button for two seconds
Transfer a call from phone to headset	Press and hold the power button for two seconds
Redial the last number	Press and hold the power button for two seconds

13. Headset indicators

The green (power) and red (mic) muting lights indicate the headset's status.

13.1 General indicator lights

Green (solid for two seconds)	Power on or pairing success via Bluetooth® discovery or automatic mode
Green (one flash every three seconds)	Connected or page scan
Green (two flashes)	Connection success
Green (two flashes every three seconds)	Active call or active voice chat
Green (six flashes)	Power off
Green and red (alternating flashes)	Pairing mode: Bluetooth® discovery
Red (solid for two seconds)	Pairing failure
Red (solid)	Charge complete
Red (one flash every three seconds)	Charging
Red (one flash every 10 seconds)	Battery low or microphone muted

13.2 Indicator lights when connected to a mobile phone

Green (one flash every three seconds)	Connected (no call or voice chat)
Green (three flashes every three seconds)	Incoming call

13.3 Headset tones

Medley	Power on or power off
One beep	Any of the following: <ul style="list-style-type: none">• Mic muting turned off• Volume adjust• Answer call• Long press of button completed for one of the following:<ul style="list-style-type: none">– Volume adjustment– Redialling last number– Transferring a call from headset to phone– Rejecting a call
One beep every three seconds	Incoming call
Two beeps	Connection success or reject call
Two beeps every 10 seconds	Mic muting on
Three beeps every 10 seconds	Battery low
One long beep	Any of the following: <ul style="list-style-type: none">• Enter pairing mode• Pairing success• Maximum volume• Minimum volume• Audio transfer• Cancel/drop call

14. Troubleshooting

My headset stopped responding.

Pair (register) the headset again with the PS3™ system using automatic mode.

Hint

Remove the headset from the list of registered devices, and then repeat the pairing process.

My headset is stuck in pairing mode (power and mic muting indicators flash alternately in green and red) and cannot be powered off.

Pair (register) the headset again with the PS3™ system using automatic mode.

Hint

Remove the headset from the list of registered devices and then repeat the pairing process.

The PS3™ system's advanced headset features do not work.

Make sure you pair the headset using automatic mode, not Bluetooth® discovery mode. Check that the PS3™ system software is version 2.50 or later. See [“5.1 Pairing with the PS3™ system: automatic mode”](#).

Audio quality is poor.

Make sure that the headset is placed correctly in your ear with the boom pointing toward the corner of your mouth. See [“9.1 Adjusting the fit”](#).

In HQ mode, there is audio latency.

Some games may exhibit long audio latency in HQ mode. Try turning off HQ mode.

My headset does not work with my phone.

Verify that your phone supports Bluetooth®.

Make sure the headset is fully charged.

Make sure the headset is paired with the phone you are trying to use.

See [“5.3 Pairing with a mobile phone”](#).

My phone did not locate the headset.

Verify that your phone supports Bluetooth®.

Turn both your phone and headset off and on, and then repeat the pairing process.

I am trying to pair my headset with a phone and cannot enter the PIN code.

Turn both your phone and headset off and on, and then repeat the pairing process.

Enter 0000 as the PIN code or pass key.

I cannot hear the caller/dial tone on my phone.	<p>The headset is not turned on. Press and hold the power button for about three seconds until a melody plays and the power indicator lights solid green, which indicates that the headset is on.</p> <p>Your headset is out of range. Move the headset closer to your phone.</p> <p>The listening volume is too low. Press the volume + button to raise the volume.</p> <p>Make sure that the headset fits properly. See “9. Wearing your headset”.</p>
Callers on my phone cannot hear me.	Your headset is out of range. Move the earpiece closer to your phone.
The earpiece ring does not fit my ear.	Try the other earpiece ring that is included with the Wireless Headset. See “ 9. Wearing your headset ”.
My headset falls off my ear.	Check that the headset is placed correctly in your ear with the boom pointing toward the corner of your mouth. See “ 9.1 Adjusting the fit ”.

15. Product specifications

Talk Time	Up to 8 hours
Standby Time	Approximately 12.5 days (300 hours)
Charge Time	3 hours
Operating Range	Up to 33 feet (10 metres)
Headset Weight	2.0 oz (58 g)
Battery Type	Lithium-ion polymer battery
Voltage	DC 3.7 V
Capacity	190 mAh
Storage/Usage Temperature	5°C to 35°C (41°F to 95°F)
Bluetooth® Version	Bluetooth® 2.1 + EDR (Enhanced Data Rate)
Bluetooth® Profiles	Headset Profile (HSP) for talking on the headset Hands-free Profile (HFP) for talking and operating the headset

Design and specifications are subject to change without notice.

16. Limited warranty

Where a 1-year warranty is supplied with your PLAYSTATION®3 system, such warranty also applies to this product. For details, please see the PLAYSTATION®3 Safety and Support Guide, available online at eu.playstation.com/ps3, or call the PLAYSTATION®3 Customer Service number, which can be found within every PLAYSTATION®3 format software manual.

“PS”, “PlayStation”, “PLAYSTATION” and “PS3” are trademarks or registered trademarks of Sony Computer Entertainment Inc. “SONY” is a registered trademarks of Sony Corporation. All rights reserved.

The Bluetooth word mark and logos are owned by the Bluetooth SIG, Inc. and any use of such marks by Sony Computer Entertainment Inc. is under licence.

