

ROBERTS

Sound for Generations



R9943

3 band PLL
Synthesised Radio

Please read this manual before use

Contents

<i>Controls</i>	2-3
<i>Display</i>	4
<i>Battery operation</i>	5
<i>Battery replacement</i>	5
<i>Mains operation</i>	5
<i>Setting the clock</i>	6
<i>Operating your radio</i>	7
<i>Scan tuning</i>	7
<i>Manual tuning</i>	8
<i>Rotary tuning</i>	9
<i>Presetting stations</i>	10
<i>Recalling a preset station</i>	11
<i>Wake to buzzer alarm</i>	12
<i>Wake to radio alarm</i>	13
<i>Snooze function</i>	14
<i>Sleep timer</i>	15
<i>Display backlight</i>	15
<i>Headphone socket</i>	16
<i>FM Stereo/Mono button</i>	16
<i>Tuning step size</i>	17
<i>Summer time</i>	18
<i>Reset button</i>	19

<i>General</i>	19
<i>Specifications</i>	20
<i>Circuit features</i>	20
<i>Mains Supply</i>	21
<i>Guarantee</i>	22

Important Information - please read before use

The batteries provide power for the clock/memory backup and must be fitted at all times.

Controls

(Top)

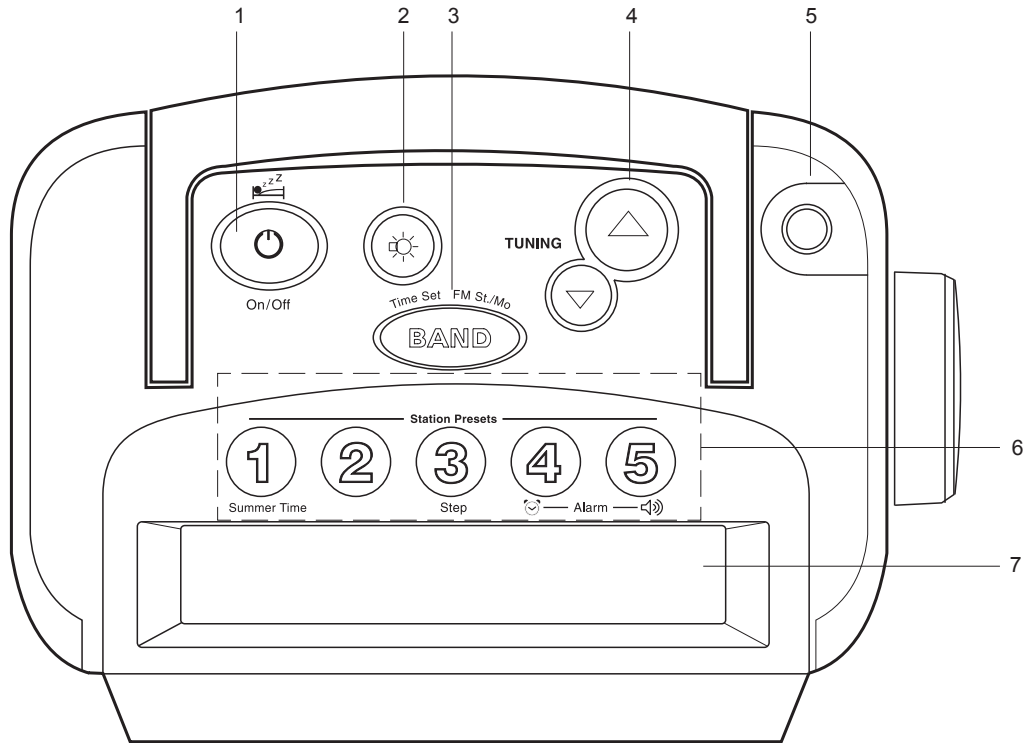

1. On/Off/Sleep button

2. Light button

3. Waveband, Time set, FM Stereo/Mono button

4. Tuning Up/Down buttons

5. Telescopic aerial

6. Preset, Summer time, Tuning step and Alarm set buttons

7. LCD display

Controls

(Right side)

- 8. Headphone socket
- 9. Tone control
- 10. Volume control
- 11. Rotary tuning control
- 12. Mains input socket (on rear)
- 13. Battery compartment (on rear)

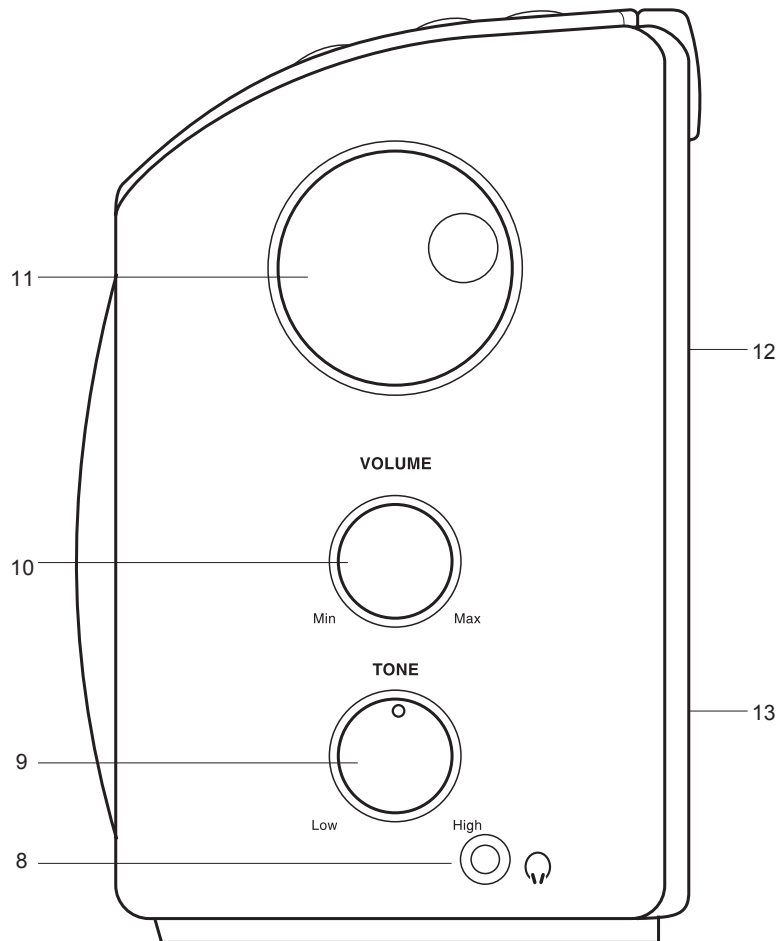

Display

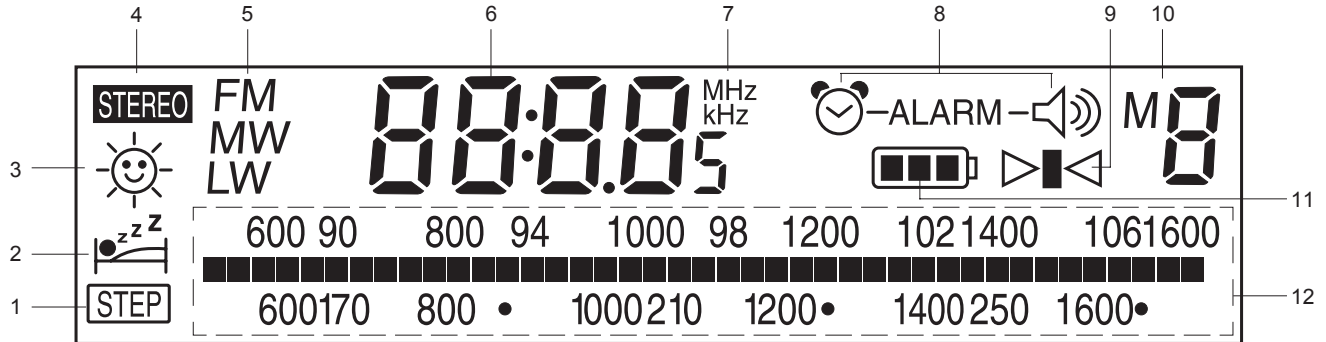

- | | |
|-------------------------------|-----------------------|
| 1. Step indicator | 8. Alarm indicators |
| 2. Sleep/Snooze indicator | 9. Tuning indicator |
| 3. Summer time indicator | 10. Memory indicator |
| 4. Stereo indicator | 11. Battery indicator |
| 5. Waveband indicators | 12. Dial scale |
| 6. Frequency/Time indicators | |
| 7. Frequency units indicators | |

Battery operation

1. Remove the **Battery cover** on the rear of the unit by pushing the catches in the direction shown by the arrows.
2. Insert four LR20 (D size) batteries into the spaces in the compartment. Take care to ensure all batteries are inserted with the correct polarity as shown inside the battery compartment. Replace the battery cover.



note : the batteries provide power for the clock/memory backup and must be fitted at all times.

3. Reduced power, distortion and a 'stuttering' sound are all signs that the batteries may need replacing.
4. If the radio is not to be used for any extended period of time it is recommended that the batteries are removed from the radio.

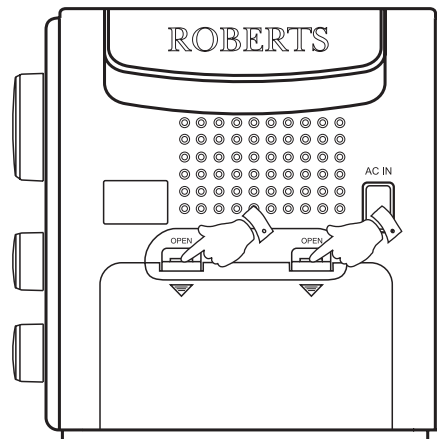
We would recommend for economy that the R9943 is used on the mains whenever possible with battery operation for occasional or stand-by use only.



Battery replacement

1. The battery indicator will appear in the display (not when connected to mains) for 7 seconds after the radio is switched on or off. The battery indicator will show  when the batteries are new. The batteries should be replaced when the battery indicator shows . If the battery power is too weak to switch on the radio the battery indicator will flash . After removing the batteries you have approximately 3 minutes to replace the batteries after which the clock and memory information will be lost.

Mains operation

1. Place your radio on a flat surface.
2. Plug the mains lead into the **Socket** located on the rear of your radio ensuring that the plug is pushed fully into the socket.
3. Plug the other end of the mains lead into a wall socket and switch on the wall socket.

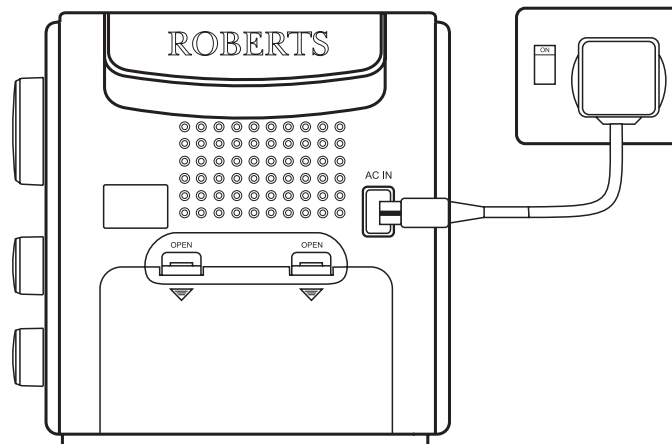

Setting the clock

1. The clock will start running when the batteries are installed or when the radio is connected to the mains supply. The display will show **0:00**.
2. Ensure that the radio switched off.
3. Press and hold down **Time set button** until the hours digits begin to flash in the display.
4. Press the **Tuning up/down** buttons to set the required hour. The clock uses the 24 hour system e.g. 2:00pm is shown as 14:00
5. Press the **Time set button**, the minute digits will flash in the display.
6. Press the **Tuning up/down** buttons to set the required minute.
7. Press the **Time set button** to complete time setting.

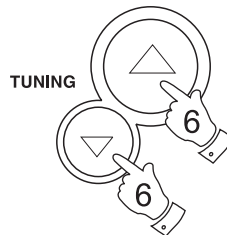
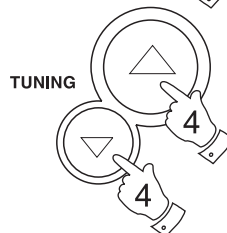
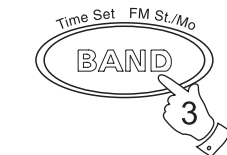

Operating your radio

Your radio is equipped with four tuning methods:- Scan tuning, Rotary tuning, Manual tuning, and Memory preset tuning. When switched on your radio will display the waveband and frequency in use. A graphical display similar to a conventional radio tuning dial will be shown in the bottom half of the display.

Scan tuning

1. Press the **On/Off button** to switch on your radio.
2. Select the required waveband by repeatedly pressing the **Band button**. For the FM waveband fully extend the **Telescopic aerial** and rotate, if necessary, to obtain best reception.
3. Press and hold down either the **Tuning up** or **Tuning down** buttons for more the 0.5 sec to commence scan tuning.
4. Your radio will scan the selected waveband and stop automatically when it finds a station of sufficient strength. The tuning indicator  and station frequency will appear in the display.
5. To recommence scan tuning, press and hold down either the **Tuning up** or **Tuning down** buttons for more the 0.5 sec.
6. When the waveband end is reached the radio will bleep and continue tuning from the opposite waveband end.
7. Set the **Volume control** and **Tone controls** to the desired settings.
8. To switch off your radio press the **On/Off button**.

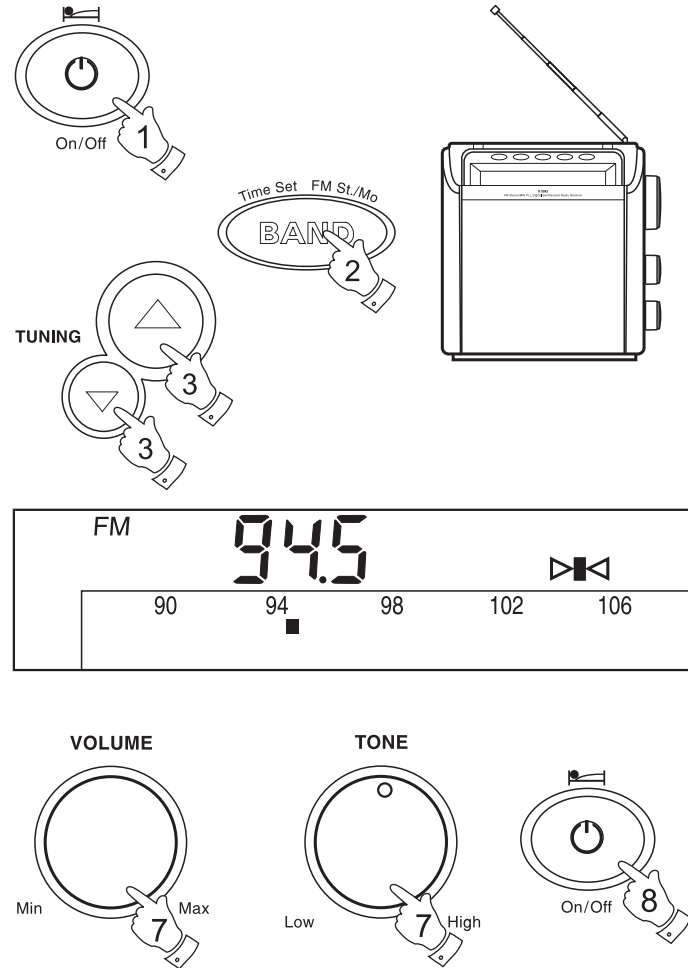

Manual tuning

1. Press the **On/Off button** to switch on your radio.
2. Select the required waveband by repeatedly pressing the **Band** button. For the FM waveband fully extend the **Telescopic aerial** angle and rotate, if necessary, to obtain best reception.
3. A single press on either the **Tuning up** or **Tuning down** buttons will change the frequency in the following increments:-

FM	50kHz or 100kHz
MW	9kHz or 10 kHz
LW	9kHz

4. When a station is correctly tuned, the tuning indicator  will appear in the display.
5. When the waveband end is reached the radio will bleep and continue tuning from the opposite waveband end.
6. Set the **Volume** and **Tone controls** to the desired settings.
7. To switch off your radio press the **On/Off button**.

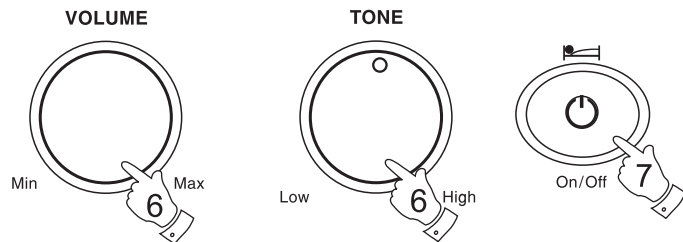
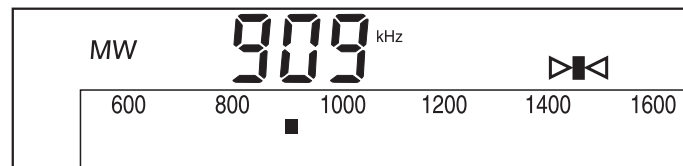
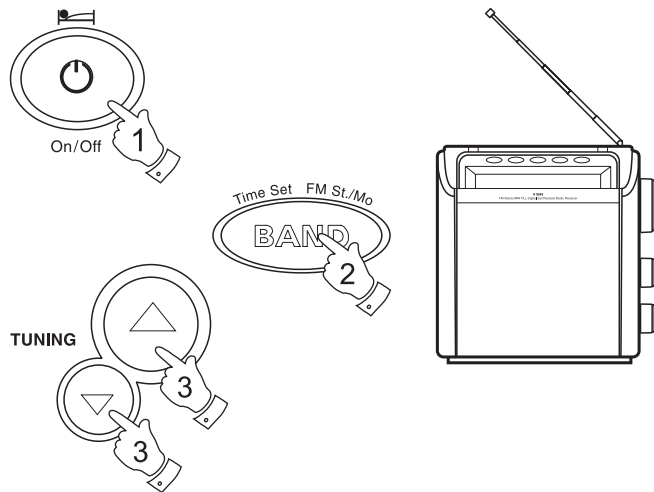

If you need any further advice, please call our Technical Helpline on :-
020 8758 0338 (Mon-Fri)

Rotary tuning

1. Press the **On/Off button** to switch on your radio.
2. Select the required waveband by repeatedly pressing the **Band** button. For the FM waveband fully extend the **Telescopic aerial** angle and rotate, if necessary, to obtain best reception.
3. Rotate the **Tuning control** to change the frequency in the following increments:-

FM	50kHz
MW	1kHz
LW	1kHz

4. When a station is correctly tuned, the tuning indicator  will appear in the display.
5. When the waveband end is reached the radio will bleep and continue tuning from the opposite waveband end.
6. Set the **Volume control** and **Tone controls** to the desired settings.
7. To switch off your radio press the **On/Off button**.

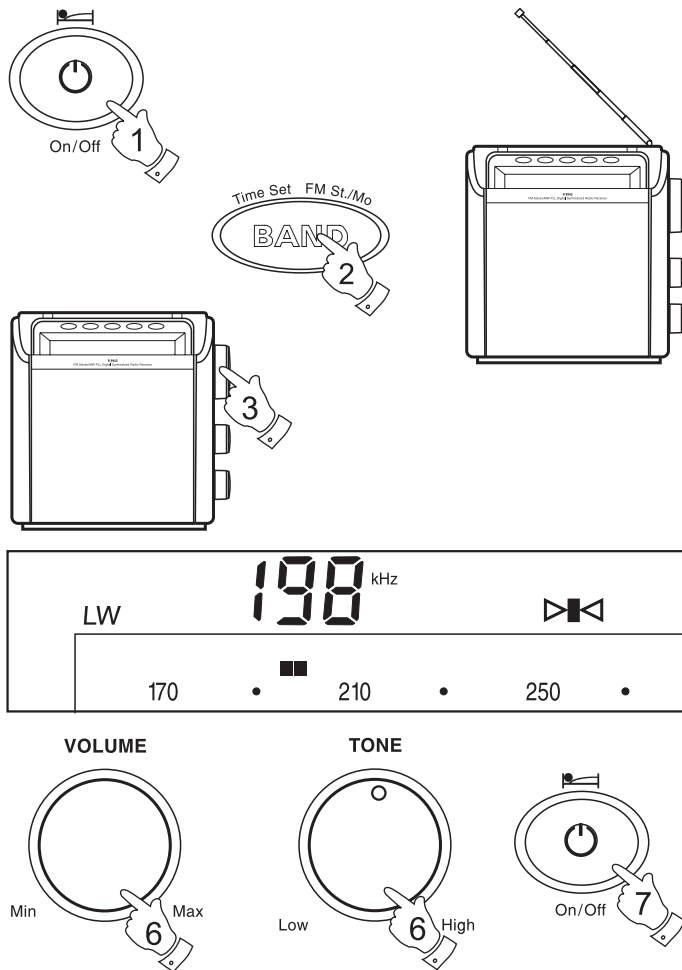

Presetting stations

There are 5 memory presets for each of the 3 wavebands.

1. Press the **On/Off button** to turn on the radio.
2. Tune to the required station using one of the methods previously described.
3. Press and hold down the required **Preset button** until the radio beeps (greater than 2 seconds) The preset number will appear in the display and the station will be stored under the chosen preset button.
4. Repeat this procedure for the remaining presets.
5. Stations stored in preset memories may be overwritten by following the above procedure.

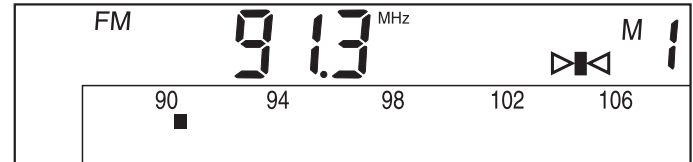
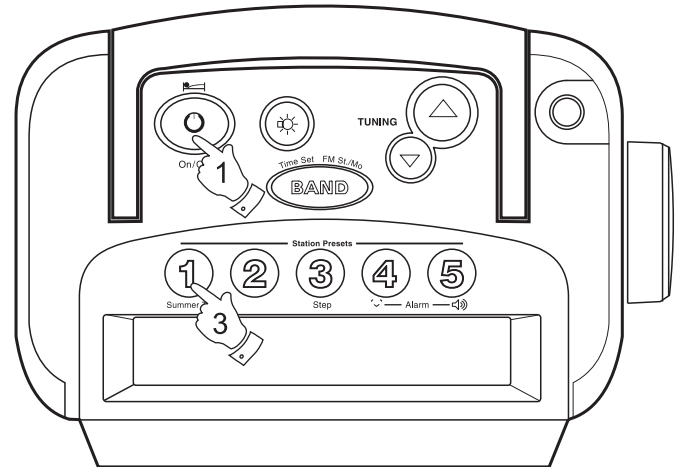



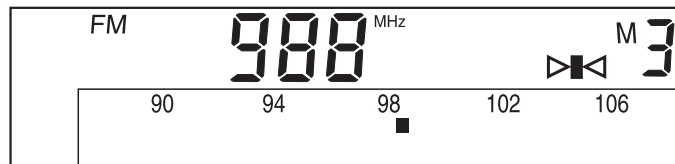
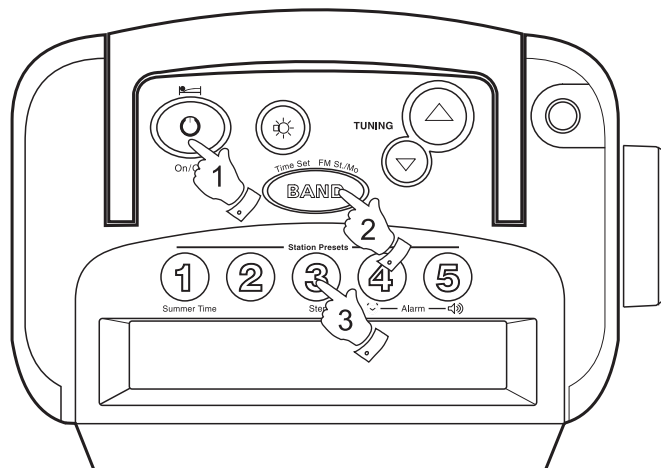

Recalling a preset station

1. Press the **On/Off button** to turn on the radio.
2. Select the required waveband by repeatedly pressing the **Band** button.
3. Momentarily press the required **Preset button**, the preset number and station frequency will appear in the display.



Wake to buzzer alarm

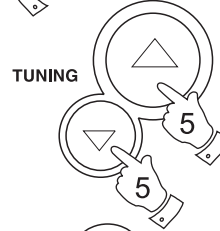
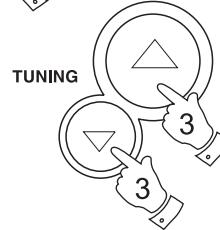

A bleep tone will sound when using the buzzer alarm. The alarm bleep will increase in volume every 15 seconds for one minute followed by one minutes silence before repeating the cycle. The buzzer alarm will sound for one hour unless turned off by pressing the **On/Off button**. Pressing the **On/Off button** whilst the alarm is sounding will cancel the alarm for 24 hours.

1. Ensure that the radio switched off.
2. Press and hold down the  **button** until the hour digits and alarm symbol flash in the display.
3. Press the **Tuning up/down** buttons to set the required hour. The clock uses the 24 hour system e.g. 2:00pm is shown as 14:00
4. Press the  **button**, the minutes digits and alarm symbol will flash in the display.
5. Press the **Tuning up/down** buttons to set the required minute.
6. Press the  **button** to complete alarm setting.
7. To permanently cancel the alarm press the  **button** until the -ALARM symbol is removed from the display.



Wake to radio alarm

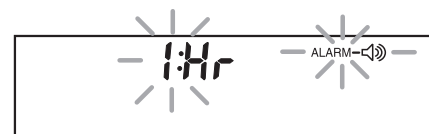
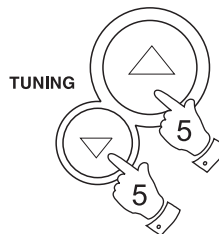
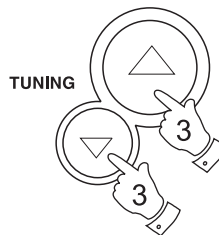

When the radio alarm is selected the radio will turn on and play the last station listened to. The radio alarm will sound for one hour unless turned off by pressing the **On/Off button**. Pressing the **On/Off button** whilst the alarm is sounding will cancel the alarm for 24 hours. The radio alarm can be set to sound for 1, 2, 3 or 4 hours. Pressing the **On/Off button** whilst the alarm is sounding will cancel the alarm for 24 hours.

1. Ensure that the radio switched off.
2. Press and hold down the **ALARM**  **button** until the hour digits and alarm symbol flash in the display.
3. Press the **Tuning up/down** buttons to set the required hour. The clock uses the 24 hour system e.g. 2:00pm is shown as 14:00
4. Press the **ALARM**  **button**, the minutes digits and alarm symbol will flash in the display.
5. Press the **Tuning up/down** buttons to set the required minute.
6. Press the **ALARM**  **button**, the radio alarm duration will flash in the display.



7. Press the **Tuning up/down** buttons to set the required radio alarm duration. (1, 2, 3 or 4 hours)

8. Press the **ALARM**  **button** to complete alarm setting.

9. To permanently cancel the alarm press the **ALARM**  **button** until the **ALARM**  symbol is removed from the display.

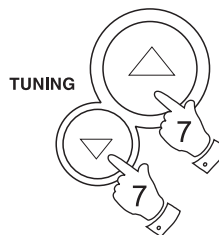

Snooze function(buzzer alarm only)





1. Whilst an alarm is sounding pressing any button (except the **On/Off** or **Light button**) will activate the snooze function. The Radio or buzzer alarms will be silenced for 5 minutes.

2. The Display will flash both the snooze symbol **zzz** and the alarm symbol -ALARM. The snooze function can be repeated during the period that the alarms are active.



Sleep timer

The sleep timer will automatically switch off the radio after a preset time has elapsed.

1. Press and continue to hold down the  **button** the display will cycle through the available sleep times in the order 90-60-30-15-90. Release the  button when the required sleep time appears in the display. The  symbol will appear in the display and the radio will play the last station selected.
2. To cancel the sleep function, press the **On/Off button**, the  symbol will disappear and the display will revert to showing real time.

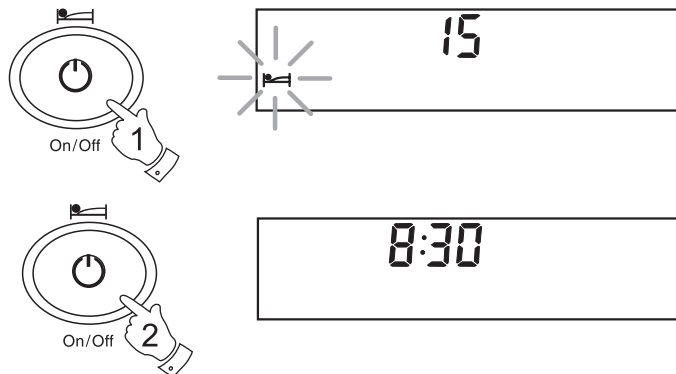

Display backlight

1. When the radio is powered via the mains the display backlight can be switched on and off by pressing the **Light button**.

When your radio is powered by batteries pressing the **Light button** or any other button will switch on the display backlight and illuminate the display for approximately 15 seconds. The display backlight may be turned off immediately by pressing the **Light button**.

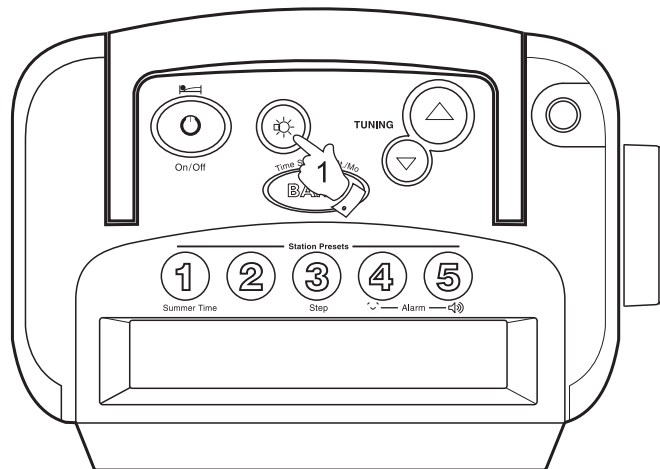

Headphone socket

A 3.5mm **Headphone Socket** located on the right-hand end of your radio is provided for use with either headphones or an earpiece. Inserting a plug automatically mutes the internal loudspeaker.



FM Stereo/Mono button

1. If a station being received is weak some hiss may be audible. To reduce the hiss press and hold down the **FM St./Mono button** to switch to mono mode. The stereo indicator will be removed from the display.

2. Press and hold down the **FM St./Mono button** to return to FM stereo operation.

Note: FM stereo is only available when using earphone/headphones

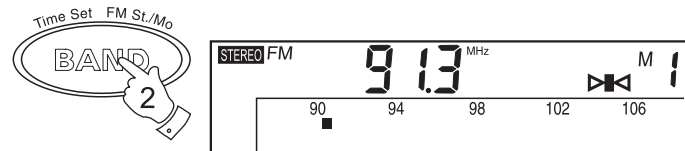
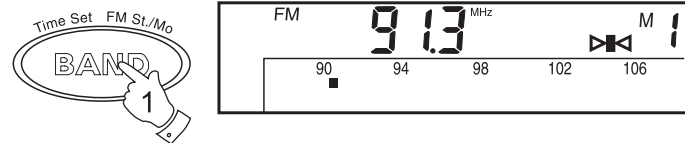

Tuning step size

In Europe and other parts of the world MW tuning steps are 9kHz, in America the MW tuning step size is 10kHz.

On FM most countries use 100kHz tuning steps, your radio can however be set so as to allow an FM tuning step size of 50kHz.

1. Ensure that your radio is switched off. Press and hold down (7sec) the **Step button** until the FM step size begins to flash in the display and then release.
2. Adjust the FM step size using the **Tuning up** or **Tuning down** buttons.
3. Press the **Step button**, the MW tuning step size will flash in the display.
4. Adjust the MW step size using the **Tuning up** or **Tuning down** buttons.
5. Press the **Step button** to complete the step size setting.

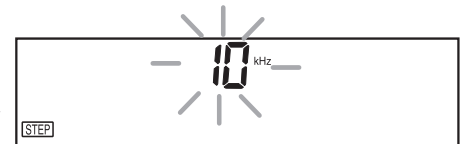
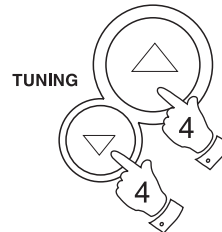
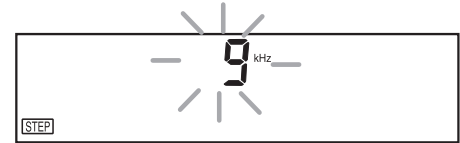
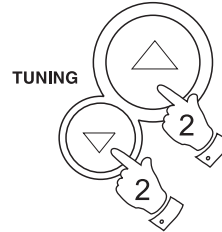
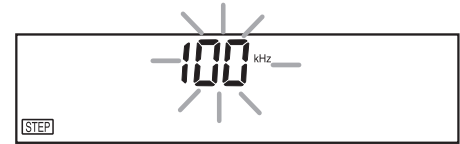

Summer time

Your radio can be set to advance the clock to summer time by pressing a single button.

1. Ensure that your radio is switched off. Press and hold down the **Summer time button** until the summer time indicator appears in the display.
2. To cancel summer time display press and hold down the **Summer time button** until the summer time indicator is removed from the display.



Reset button

If your radio fails to operate correctly, or some digits on the display are missing or incomplete carry out the following procedure.

1. With the aid of a suitable implement (the end of a paper clip) press the reset button located on the underside of your radio for at least 5 seconds, this will reset the microprocessor, clock time and clear all stations stored in preset memory.

If a problem persists our technical staff would be pleased to help offer any assistance on operating the radio. Our technical helpline number is 020 8758 0338.

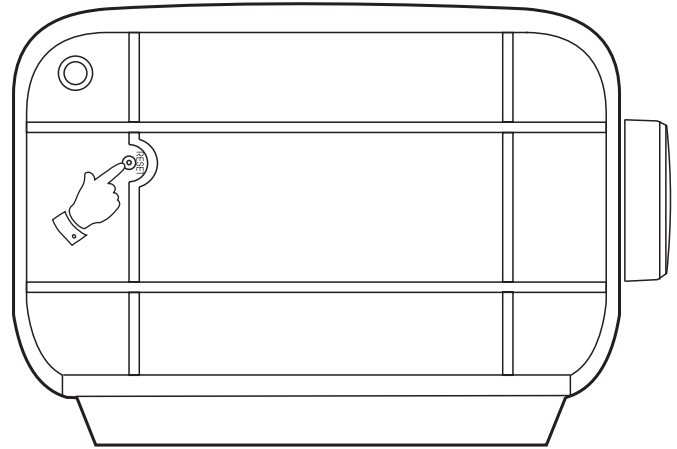

General

Do not allow this radio to be exposed to water, steam or sand. Do not leave your radio where excessive heat could cause damage such as in a parked car where the heat from the sun can build up even though the outside temperature may not seem too high. It is recommended that the FM band be used wherever possible as better results in terms of quality and freedom from interference will usually be obtained than on the MW or LW bands.

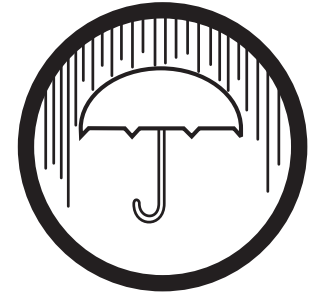
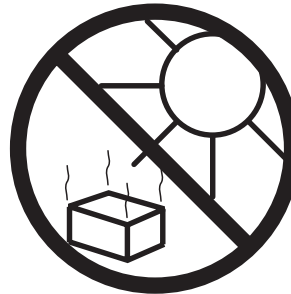

Specifications

Power Requirements

Mains	AC 230 volts, 50Hz  only
Batteries	4 x LR20 (D size)

Battery Life

Approx. 70 hours of listening for 4 hours a day at normal volume using alkaline cells.

Frequency Coverage

FM	87.5-108MHz
MW	522- 1629kHz
LW	153- 279kHz

Circuit Features

Loudspeaker	Woofers	125mm 4ohms
	Tweeter	38mm 4 ohms
Output Power	Mains	1.4 Watts
	Batteries	0.8 Watts
Headphone socket	3.5mm dia	
Aerial System	FM	Telescopic aerial
	MW	Built-in Ferrite aerial
	LW	Built-in Ferrite aerial

Mains supply

The R9943 will operate from a supply of AC 230 volts, 50Hz \sim only.

DO NOT cut off the mains plug from this equipment. If the plug fitted is not suitable for the power points in your home or the cable is too short to reach a power point, then obtain an appropriate safety approved extension lead or adaptor. If in doubt consult your dealer.

If nonetheless the mains plug is cut off, remove the fuse and dispose of the plug immediately, to avoid a possible shock hazard by inadvertent connection to the mains supply.

If this product is not supplied with a mains plug, or one has to be fitted, then follow the instructions given below:

IMPORTANT. DO NOT make any connection to the larger terminal which is marked with the letter E or by the safety earth symbol \perp or coloured Green or Green-and-yellow.

The wires in the mains lead are coloured in accordance with the following codes :-

BLUE - NEUTRAL

BROWN - LIVE

The wire coloured BLUE must be connected to the terminal marked N or coloured BLACK.

The wire coloured BROWN must be connected to the terminal marked L or coloured RED.

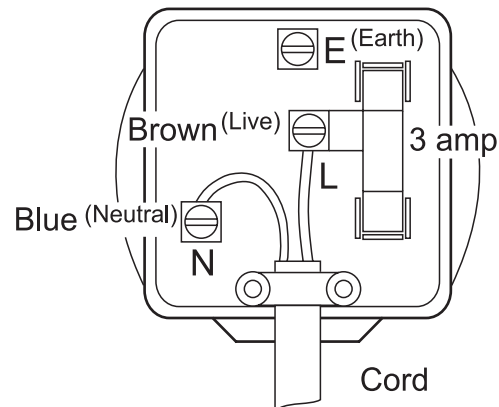

Fuse

When replacing the fuse only a 3A ASTA approved to BS1362 type should be used and be sure to re-fit the fuse cover.

IF IN DOUBT - CONSULT A QUALIFIED ELECTRICIAN.

Replacement fuse holders are available from Roberts Radio Technical Services at the address shown on the rear of this manual.

Guarantee

This instrument is guaranteed for twelve months from the date of delivery to the original owner against failure due to faulty workmanship or component breakdown, subject to the procedure stated below. Should any component or part fail during this guarantee period it will be repaired or replaced free of charge.

The guarantee does not cover:

1. Damage resulting from incorrect use.
2. Consequential damage.
3. Receivers with removed or defaced serial numbers.

N.B. Damaged or broken telescopic aerials will not be replaced under guarantee.

Procedure:

Any claim under this guarantee should be made through the dealer from whom the instrument was purchased. It is likely that your Roberts' dealer will be able to attend to any defect quickly and efficiently, but should it be necessary the dealer will return the instrument to the company's service department for attention. In the event that it is not possible to return the instrument to the Roberts' dealer from whom it was purchased, please contact Roberts Radio Technical Services at the address shown on the rear of this manual.

These statements do not affect the statutory rights of a consumer.

*If you need any further advice, please call our Technical Helpline on :-
020 8758 0338 (Mon-Fri)*

ROBERTS RADIOTECHNICAL SERVICES

97-99 Worton Road

Isleworth Middlesex

TW7 6EG

Technical Helpline :- 020 8758 0338 (*Mon-Fri during office hours*)