

# *Cub Cadet*<sup>®</sup>

## OPERATOR'S MANUAL

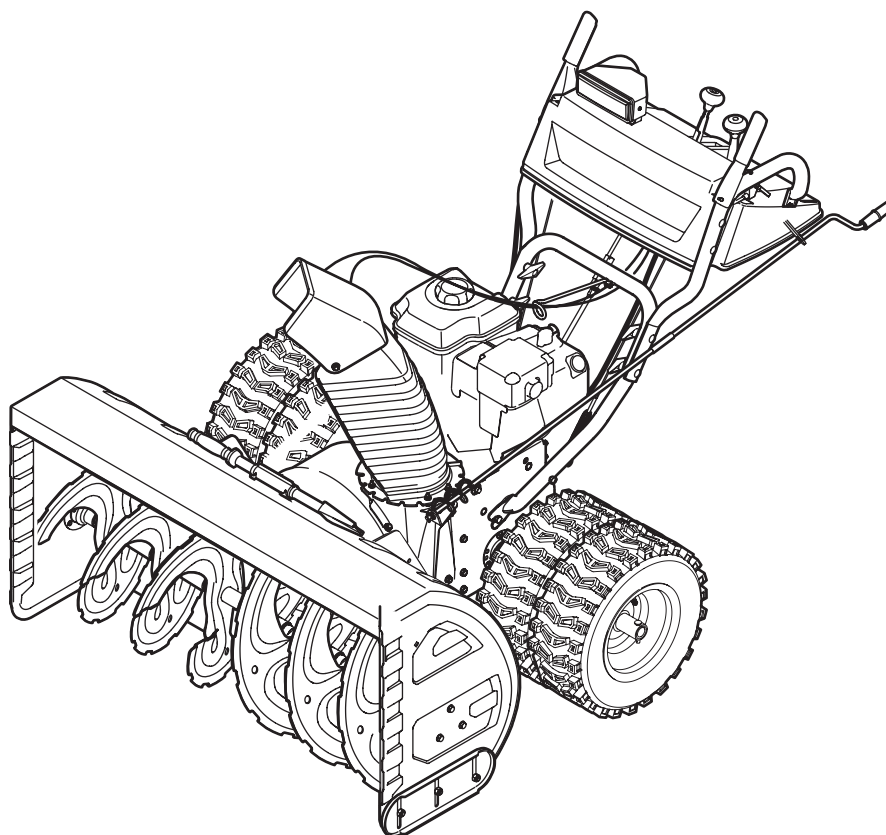

### Two Stage Snow Thrower — 945 SWE

#### **⚠ WARNING**

**READ AND FOLLOW ALL SAFETY RULES AND INSTRUCTIONS IN THIS MANUAL  
BEFORE ATTEMPTING TO OPERATE THIS MACHINE.  
FAILURE TO COMPLY WITH THESE INSTRUCTIONS MAY RESULT IN PERSONAL INJURY.**

---

CUB CADET LLC, P.O. BOX 361131 CLEVELAND, OHIO 44136-0019

---

## Thank You

Thank you for purchasing a Snow Thrower manufactured by Cub Cadet LLC. It was carefully engineered to provide excellent performance when properly operated and maintained.

Please read this entire manual prior to operating the equipment. It instructs you how to safely and easily set up, operate and maintain your machine. Please be sure that you, and any other persons who will operate the machine, carefully follow the recommended safety practices at all times. Failure to do so could result in personal injury or property damage.

All information in this manual is relative to the most recent product information available at the time of printing. Review this manual frequently to familiarize yourself with the machine, its features and operation. Please be aware that this Operator's Manual may cover a range of product specifications for various models. Characteristics and features discussed and/or illustrated in this manual may not be applicable to all models. Cub Cadet LLC reserves the right to change product specifications, designs and equipment without notice and without incurring obligation.

If you have any problems or questions concerning the machine, phone your local Cub Cadet dealer or contact us directly. Cub Cadet's Customer Support telephone numbers, website address and mailing address can be found on this page. We want to ensure your complete satisfaction at all times.

Throughout this manual, all references to *right* and *left* side of the machine are observed from the operating position..

## Table of Contents

<b>Important Safe Operation Practices.....</b>	<b>3</b>	<b>Service .....</b>	<b>19</b>
<b>Assembly &amp; Set-Up .....</b>	<b>7</b>	<b>Troubleshooting .....</b>	<b>24</b>
<b>Controls and Features .....</b>	<b>11</b>	<b>Replacement Parts .....</b>	<b>25</b>
<b>Operation .....</b>	<b>14</b>	<b>Warranty .....</b>	<b>Back Cover</b>
<b>Maintenance &amp; Adjustment.....</b>	<b>16</b>		

## Record Product Information

Before setting up and operating your new equipment, please locate the model plate on the equipment and record the information in the provided area to the right. You can locate the model plate by standing at the operator's position and looking at the lower, rear section of the frame. This information will be necessary, should you seek technical support via our web site, Customer Support Department, or with a local authorized service dealer.

### MODEL NUMBER

--	--	--	--	--	--	--	--	--	--	--	--

### SERIAL NUMBER

--	--	--	--	--	--	--	--	--	--	--	--

## Customer Support

If you have difficulty assembling this product or have any questions regarding the controls, operation, or maintenance of this unit, you can seek help from the experts. Choose from the options below:

- ◇ Visit us on the web at [www.cubcadet.com](http://www.cubcadet.com)
- ◇ Locate your nearest Cub Cadet Dealer at (877) 282-8684
- ◇ Write us at Cub Cadet LLC • P.O. Box 361131 • Cleveland, OH • 44136-0019



**WARNING!** This symbol points out important safety instructions which, if not followed, could endanger the personal safety and/or property of yourself and others. Read and follow all instructions in this manual before attempting to operate this machine. Failure to comply with these instructions may result in personal injury. When you see this symbol. **HEED ITS WARNING!**

## CALIFORNIA PROPOSITION 65



**WARNING!** Engine Exhaust, some of its constituents, and certain vehicle components contain or emit chemicals known to State of California to cause cancer and birth defects or other reproductive harm.



**DANGER:** This machine was built to be operated according to the safe operation practices in this manual. As with any type of power equipment, carelessness or error on the part of the operator can result in serious injury. This machine is capable of amputating fingers, hands, toes and feet and throwing foreign objects. Failure to observe the following safety instructions could result in serious injury or death.

### Training

1. Read, understand, and follow all instructions on the machine and in the manual(s) before attempting to assemble and operate. Keep this manual in a safe place for future and regular reference and for ordering replacement parts.
2. Be familiar with all controls and their proper operation. Know how to stop the machine and disengage them quickly.
3. Never allow children under 14 years of age to operate this machine. Children 14 and over should read and understand the instructions and safe operation practices in this manual and on the machine and be trained and supervised by an adult.
4. Never allow adults to operate this machine without proper instruction.
5. Thrown objects can cause serious personal injury. Plan your snow-throwing pattern to avoid discharge of material toward roads, bystanders and the like.
6. Keep bystanders, pets and children at least 75 feet from the machine while it is in operation. Stop machine if anyone enters the area.
7. Exercise caution to avoid slipping or falling, especially when operating in reverse.

### Preparation

Thoroughly inspect the area where the equipment is to be used. Remove all doormats, newspapers, sleds, boards, wires and other foreign objects, which could be tripped over or thrown by the auger/impeller.

1. Always wear safety glasses or eye shields during operation and while performing an adjustment or repair to protect your eyes. Thrown objects which ricochet can cause serious injury to the eyes.
2. Do not operate without wearing adequate winter outer garments. Do not wear jewelry, long scarves or other loose clothing, which could become entangled in moving parts. Wear footwear which will improve footing on slippery surfaces.
3. Use a grounded three-wire extension cord and receptacle for all machines with electric start engines.
4. Adjust collector housing height to clear gravel or crushed rock surfaces.
5. Disengage all control levers before starting the engine.
6. Never attempt to make any adjustments while engine is running, except where specifically recommended in the operator's manual.
7. Let engine and machine adjust to outdoor temperature before starting to clear snow.

## Safe Handling of Gasoline

To avoid personal injury or property damage use extreme care in handling gasoline. Gasoline is extremely flammable and the vapors are explosive. Serious personal injury can occur when gasoline is spilled on yourself or your clothes which can ignite. Wash your skin and change clothes immediately.

- a. Use only an approved gasoline container.
- b. Extinguish all cigarettes, cigars, pipes and other sources of ignition.
- c. Never fuel machine indoors.
- d. Never remove gas cap or add fuel while the engine is hot or running.
- e. Allow engine to cool at least two minutes before refueling.
- f. Never over fill fuel tank. Fill tank to no more than ½ inch below bottom of filler neck to provide space for fuel expansion.
- g. Replace gasoline cap and tighten securely.
- h. If gasoline is spilled, wipe it off the engine and equipment. Move machine to another area. Wait 5 minutes before starting the engine.
- i. Never store the machine or fuel container inside where there is an open flame, spark or pilot light (e.g. furnace, water heater, space heater, clothes dryer etc.).
- j. Allow machine to cool at least 5 minutes before storing.
- k. Never fill containers inside a vehicle or on a truck or trailer bed with a plastic liner. Always place containers on the ground away from your vehicle before filling.
- l. If possible, remove gas-powered equipment from the truck or trailer and refuel it on the ground. If this is not possible, then refuel such equipment on a trailer with a portable container, rather than from a gasoline dispenser nozzle.
- m. Keep the nozzle in contact with the rim of the fuel tank or container opening at all times until fueling is complete. Do not use a nozzle lock-open device.

## Operation

1. Do not put hands or feet near rotating parts, in the auger/impeller housing or chute assembly. Contact with the rotating parts can amputate hands and feet.
2. The auger/impeller control lever is a safety device. Never bypass its operation. Doing so makes the machine unsafe and may cause personal injury.
3. The control levers must operate easily in both directions and automatically return to the disengaged position when released.
4. Never operate with a missing or damaged chute assembly. Keep all safety devices in place and working.
5. Never run an engine indoors or in a poorly ventilated area. Engine exhaust contains carbon monoxide, an odorless and deadly gas.
6. Do not operate machine while under the influence of alcohol or drugs.
7. Muffler and engine become hot and can cause a burn. Do not touch. Keep children away.
8. Exercise extreme caution when operating on or crossing gravel surfaces. Stay alert for hidden hazards or traffic.
9. Exercise caution when changing direction and while operating on slopes.
10. Plan your snow-throwing pattern to avoid discharge towards windows, walls, cars etc. Thus, avoiding possible property damage or personal injury caused by a ricochet.
11. Never direct discharge at children, bystanders and pets or allow anyone in front of the machine.
12. Do not overload machine capacity by attempting to clear snow at too fast of a rate.
13. Never operate this machine without good visibility or light. Always be sure of your footing and keep a firm hold on the handles. Walk, never run.
14. Disengage power to the auger/impeller when transporting or not in use.
15. Never operate machine at high transport speeds on slippery surfaces. Look down and behind and use care when backing up.
16. If the machine should start to vibrate abnormally, stop the engine, disconnect the spark plug wire and ground it against the engine. Inspect thoroughly for damage. Repair any damage before starting and operating.
17. Disengage all control levers and stop engine before you leave the operating position (behind the handles). Wait until the auger/impeller comes to a complete stop before unlogging the chute assembly, making any adjustments, or inspections.
18. Never put your hand in the discharge or collector openings. Always use the clean-out tool provided to unplug the discharge opening. Do not unplug chute assembly while engine is running. Shut off engine and remain behind handles until all moving parts have stopped before unlogging.
19. Use only attachments and accessories approved by the manufacturer (e.g. wheel weights, tire chains, cabs etc.).
20. When starting engine, pull cord slowly until resistance is felt, then pull rapidly. Rapid retraction of starter cord (kickback) will pull hand and arm toward engine faster than you can let go. Broken bones, fractures, bruises or sprains could result.
21. If situations occur which are not covered in this manual, use care and good judgment. Contact Customer Support for assistance and the name of your nearest servicing dealer.

## Maintenance & Storage

1. Never tamper with safety devices. Check their proper operation regularly. Refer to the maintenance and adjustment sections of this manual.
2. Before cleaning, repairing, or inspecting machine disengage all control levers and stop the engine. Wait until the auger/impeller come to a complete stop. Disconnect the spark plug wire and ground against the engine to prevent unintended starting.
3. Check bolts and screws for proper tightness at frequent intervals to keep the machine in safe working condition. Also, visually inspect machine for any damage.
4. Do not change the engine governor setting or over-speed the engine. The governor controls the maximum safe operating speed of the engine.
5. Snow thrower shave plates and skid shoes are subject to wear and damage. For your safety protection, frequently check all components and replace with original equipment manufacturer's (OEM) parts only. "Use of parts which do not meet the original equipment specifications may lead to improper performance and compromise safety!"
6. Check control levers periodically to verify they engage and disengage properly and adjust, if necessary. Refer to the adjustment section in this operator's manual for instructions.
7. Maintain or replace safety and instruction labels, as necessary.
8. Observe proper disposal laws and regulations for gas, oil, etc. to protect the environment.
9. Prior to storing, run machine a few minutes to clear snow from machine and prevent freeze up of auger/impeller.
10. Never store the machine or fuel container inside where there is an open flame, spark or pilot light such as a water heater, furnace, clothes dryer etc.
11. Always refer to the operator's manual for proper instructions on off-season storage.
12. Check fuel line, tank, cap, and fittings frequently for cracks or leaks. Replace if necessary.
13. Do not crank engine with spark plug removed.
14. According to the Consumer Products Safety Commission (CPSC) and the U.S. Environmental Protection Agency (EPA), this product has an *Average Useful Life* of seven (7) years, or 60 hours of operation. At the end of the *Average Useful Life* have the machine inspected annually by an authorized service dealer to ensure that all mechanical and safety systems are working properly and not worn excessively. Failure to do so can result in accidents, injuries or death.

## Do not modify engine

To avoid serious injury or death, do not modify engine in any way. Tampering with the governor setting can lead to a runaway engine and cause it to operate at unsafe speeds. Never tamper with factory setting of engine governor.

## Notice Regarding Emissions

Engines which are certified to comply with California and federal EPA emission regulations for SORE (Small Off Road Equipment) are certified to operate on regular unleaded gasoline, and may include the following emission control systems: Engine Modification (EM), Oxidizing Catalyst (OC), Secondary Air Injection (SAI) and Three Way Catalyst (TWC) if so equipped.

## Spark Arrestor











**WARNING!** This machine is equipped with an internal combustion engine and should not be used on or near any unimproved forest-covered, brush covered or grass-covered land unless the engine's exhaust system is equipped with a spark arrester meeting applicable local or state laws (if any).

If a spark arrester is used, it should be maintained in effective working order by the operator. In the State of California the above is required by law (Section 4442 of the California Public Resources Code). Other states may have similar laws. Federal laws apply on federal lands.

A spark arrester for the muffler is available through your nearest engine authorized service dealer or contact the service department, P.O. Box 361131 Cleveland, Ohio 44136-0019.

## Safety Symbols

This page depicts and describes safety symbols that may appear on this product. Read, understand, and follow all instructions on the machine before attempting to assemble and operate.

Symbol	Description
	<b>READ THE OPERATOR'S MANUAL(S)</b> Read, understand, and follow all instructions in the manual(s) before attempting to assemble and operate
	<b>WARNING— ROTATING BLADES</b> Keep hands out of inlet and discharge openings while machine is running. There are rotating blades inside
	<b>WARNING— ROTATING BLADES</b> Keep hands out of inlet and discharge openings while machine is running. There are rotating blades inside
	<b>WARNING— ROTATING AUGER</b> Do not put hands or feet near rotating parts, in the auger/impeller housing or chute assembly. Contact with the rotating parts can amputate hands and feet.
	<b>WARNING—THROWN OBJECTS</b> This machine may pick up and throw and objects which can cause serious personal injury.
	<b>WARNING—GASOLINE IS FLAMMABLE</b> Allow the engine to cool at least two minutes before refueling.
	<b>WARNING— CARBON MONOXIDE</b> Never run an engine indoors or in a poorly ventilated area. Engine exhaust contains carbon monoxide, an odorless and deadly gas.
	<b>WARNING— ELECTRICAL SHOCK</b> Do not use the engine's electric starter in the rain



**WARNING!** Your Responsibility—Restrict the use of this power machine to persons who read, understand and follow the warnings and instructions in this manual and on the machine.

**SAVE THESE INSTRUCTIONS!**

## Contents of Carton

- One Snow Thrower
- One Snow Thrower Operator's Manual
- Two Replacement Auger Shear Pins
- One Briggs & Stratton Engine Operator's Manual
- One Chute Assembly
- One Product Registration Card

## Assembly

**IMPORTANT:** Two replacement auger shear pins are included with this manual (or stowed in the plastic handle panel). Refer to the Maintenance section for more information regarding shear pin replacement.

**NOTE:** All references in this manual to the left or right side of the snow thrower is from the operating position only. Exceptions, if any, will be specified.

**IMPORTANT:** This unit is shipped with the engine full of oil. After assembly, refer to the separate Engine Owner's Manual included with this unit for fuel and oil fill-up details.

**NOTE:** Specifications are subject to change without notification or obligation. Images may not reflect your exact model and are for reference purposes only.

### Handle

1. Remove any packaging material from the upper handle.
2. Remove the lower plastic wing nut, Belleville washer and carriage bolt from each side of the upper handle; then raise the upper handle assembly until it snaps over the lower handle. See Figure 3-1.

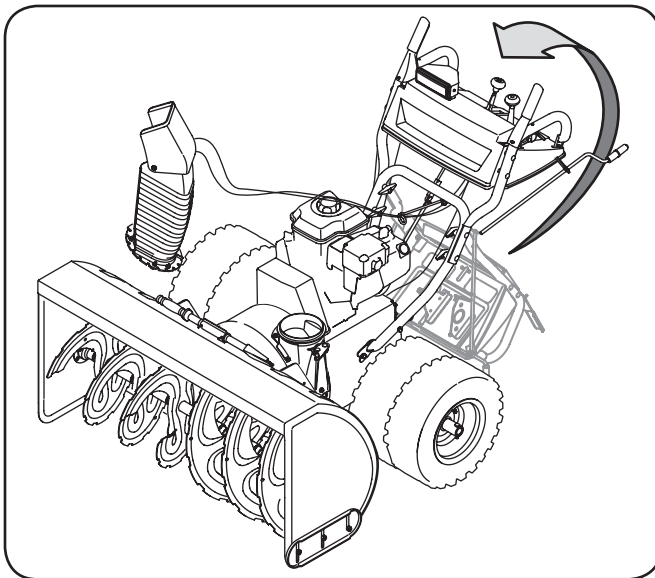

Figure 3-1

3. Looking beneath the handle panel, check that all of the cables (steering, auger, and drive) are properly routed and not pinched or kinked. Make certain the springs at the lower end of the auger and drive cables are securely hooked into their respective actuator bracket.

4. Secure the upper handle and lower handle with the two wing nuts and carriage bolts removed earlier. Tighten the two wing nuts already installed in the upper holes to firmly secure the upper handle and support tubes. See Figure 3-2.

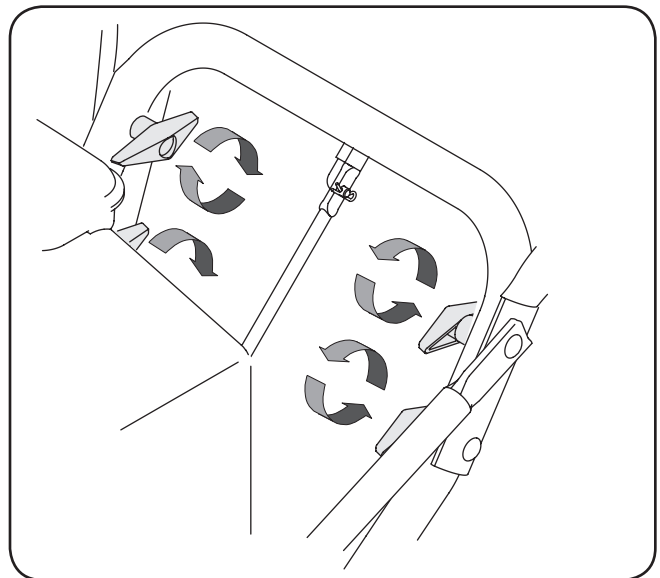

Figure 3-2

5. Align the upper and lower shift rods, then slide the shift rod connector down over the end of the lower shift rod. Tap the connector until the lower rod is completely through the connector. See Figure 3-3.

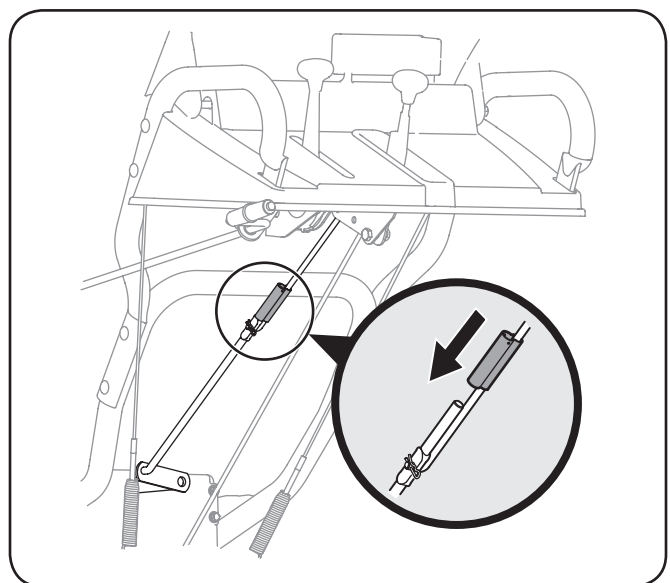

Figure 3-3

**NOTE:** If the connector is not properly assembled, the shift rod will pivot and you will not be able to change speeds or direction. If the full range of speeds (forward and reverse) can not be achieved, refer to the "Maintenance and Adjustments" section.

### Chute Directional Control

Remove the internal cotter pin from the upper chute crank. Slide the upper chute crank into the sleeve on the lower chute crank.

Align the hole in the upper chute crank with the hole in the sleeve (If necessary, use a pair of pliers to assist in aligning holes). Insert the internal cotter pin through the holes to secure the chute crank. See Figure 3-4.

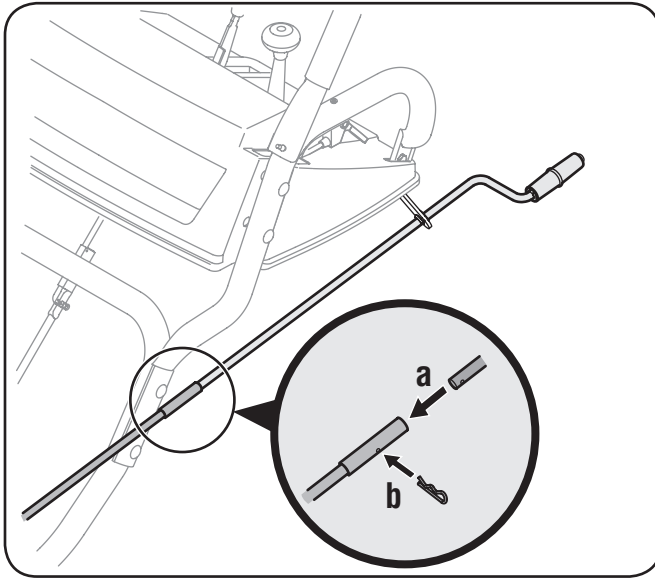

Figure 3-4

### Chute Assembly

Remove lock nuts and screws securing one of the flange keepers to the chute assembly. Loosen the fasteners of the other two flange keepers. See Figure 3-5.

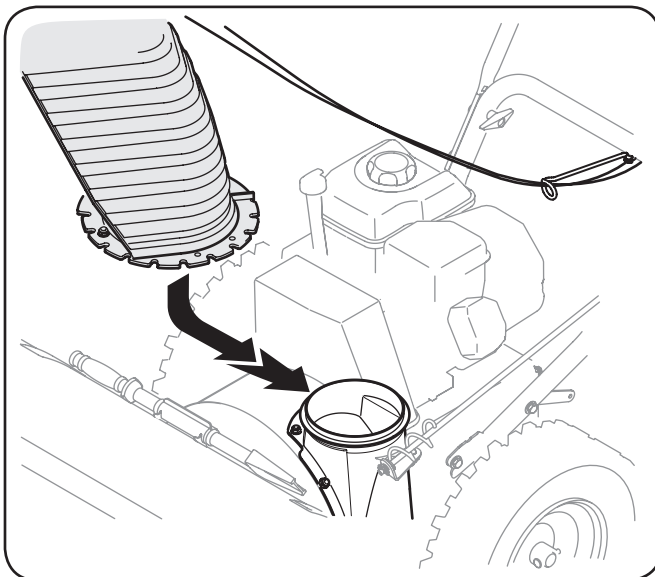

Figure 3-5

Place chute assembly onto chute base as shown in Figure 3-5. Make sure that the chute notches engage with the spiral end of chute directional control, and the two flange keepers are beneath the flange on the chute base.

Secure flange keeper removed earlier with lock nuts and screws. Tighten down nuts securing the other two flange keepers. See Figure 3-6.

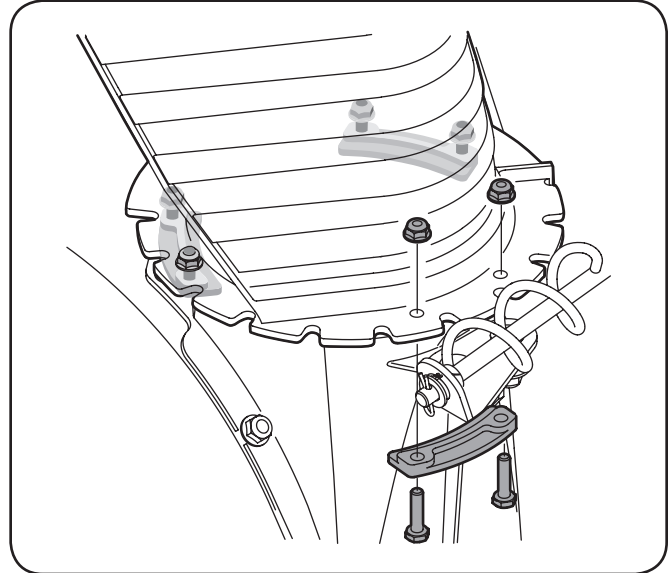

Figure 3-6

Check that the chute cables are properly routed through the cable guide attached to the lower handle assembly. See Figure 3-5.



## Set-Up

### Shear Pins

A pair of replacement auger shear pins and bow tie cotter pins have been included with your snow thrower. Store the pins in a convenient place for use if an original equipment shear pin should break.

### Chute Clean-Out Tool

The chute clean-out tool is fastened to the top of the auger housing with a mounting clip and a cable tie at the factory. Cut the cable tie before operating the snow thrower.

### Tire Pressure (Pneumatic Tires)

The tires are over-inflated for shipping purposes. Check the tire pressure before operating the snow thrower. Refer to the tire side wall for tire manufacturer's recommended psi and deflate (or inflate) the tires as necessary.

**NOTE:** If the tire pressure is not equal in all tires, the unit may pull to one side or the other and the shave plate will not sit level on the ground.

**IMPORTANT:** Under any circumstance do not exceed manufacturer's recommended psi. Equal tire pressure should be maintained at all times. Excessive pressure when seating beads may cause tire/rim assembly to burst with force sufficient to cause serious injury. Refer to sidewall of tire for recommended pressure.

## Adjustments

### Skid Shoes

The snow thrower skid shoes are adjusted upward at the factory for shipping purposes. Adjust them downward prior to operating the snow thrower.



**CAUTION:** It is not recommended that you operate this snow thrower on gravel as it can easily pick up and throw loose gravel, causing personal injury or damage to the snow thrower and surrounding property.

For close snow removal on a smooth surface, adjust the skid shoes so that the shave plate on the bottom of the auger housing is just off the ground.

Adjust the skid shoes to a lower position to raise the shave plate off the ground when clearing uneven areas, such as a ribbon type driveway or a gravel driveway

**NOTE:** If you choose to operate the snow thrower on a gravel surface, keep the skid shoes in position for maximum clearance between the ground and the shave plate.

### To adjust the skid shoes:

1. Adjust skid shoes by loosening the six (three on each side) hex nuts, washers, and carriage bolts securing the skid shoes to the auger housing. Refer to Figure 3-7.
2. While observing the distance between the shave plate and the ground, adjust the skid shoes up or down to achieve the desired shave plate height. See Figure 3-7.
3. Make certain the entire bottom surface of skid shoes are against the ground to avoid uneven wear on the skid shoes; then tighten nuts and bolts securely.

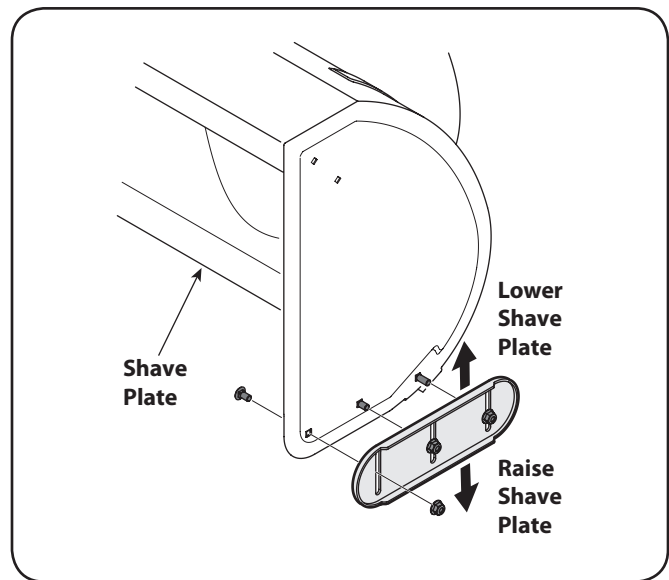

Figure 3-7

### Auger and Drive Control Cables



**WARNING!** Prior to operating your snow thrower, carefully read and follow all instructions below. Perform all adjustments to verify your snow thrower is operating safely and properly.

### Testing Auger Drive Control

When the auger control is released and in the disengaged "up" position, the cable should have very little slack. It should NOT be tight. Refer to Figure 3-8.

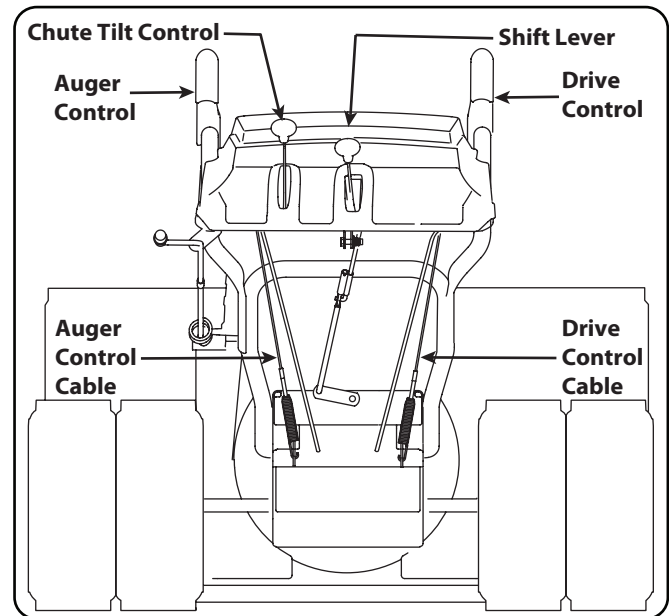

Figure 3-8

1. In a well-ventilated area, start the snow thrower engine as instructed in Section 5 - Operation.
2. While standing in the operator's position (behind the snow thrower), engage the auger.
3. Allow the auger to remain engaged for approximately ten (10) seconds before releasing the auger control. Repeat this several times.

4. With the auger control in the disengaged “up” position, walk to the front of the machine.
5. Confirm that the auger has completely stopped rotating and shows NO signs of motion. If the auger shows ANY signs of rotating, immediately return to the operator’s position and shut off the engine. Wait for ALL moving parts to stop before re-adjusting the auger control.

### Testing Drive Control & Shift Lever

1. With the engine turned off, move the shift lever into sixth (6) position. Refer to Figure 3-8.
2. With the wheel drive control released, push the snow thrower forward, then pull it back. The machine should move freely.
3. Engage the drive control and attempt to move the machine both forward and back, resistance should be felt.
4. Move the shift lever into the fast reverse (R2) position and repeat the previous two steps.
5. If you experienced resistance rolling the unit, either when repositioning the shift lever from 6 to R2 or when attempting to move the machine with the drive control released, adjust the drive control immediately. See Adjusting Drive and Auger Controls.

### Adjusting Drive and Auger Controls

1. From beneath the handle, pull downward on the appropriate cable and unhook the spring found on the end of the cable from its respective actuator bracket. Refer to Figures 3-9 and 3-10.

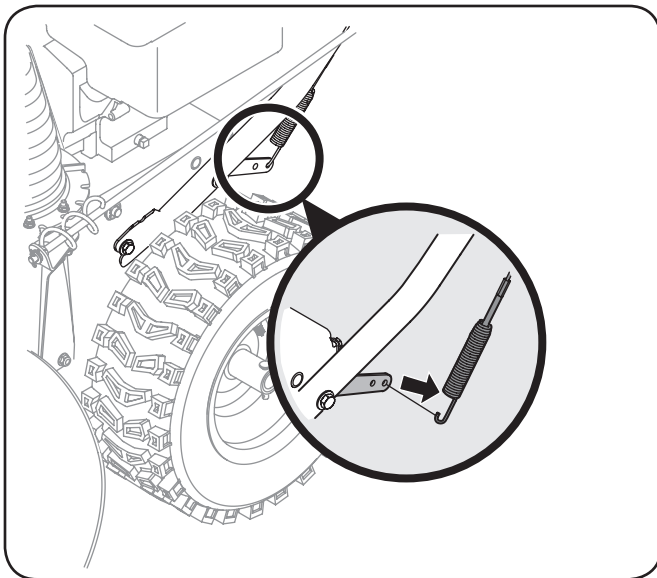

Figure 3-9

2. Slide the spring up the cable to expose the cable coupler threads and lock nut. Refer to Figure 3-10.
3. Adjust the lock nut as follows: If adjusting the drive cable, thread the lock nut outward (down the coupler) to lengthen the cable and allow the unit to move freely when the control is released. Thread the lock nut inward (up the coupler) to shorten the cable to reduce slippage and prevent the machine from being easily moved with the drive control engaged.

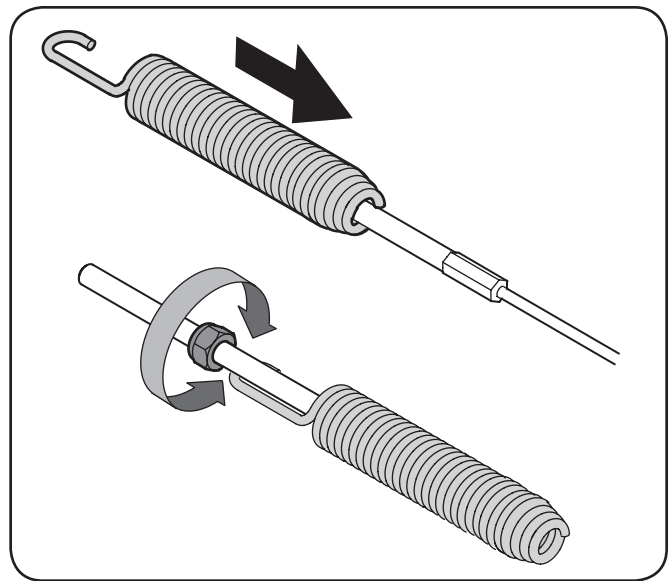

Figure 3-10



**WARNING!** Do not over-tighten the cable. Over-tightening may prevent the auger from disengaging and compromise the safety of the snow thrower.

4. If adjusting the auger cable, thread the lock nut down to lengthen the cable as necessary to stop the auger from turning when the control is released.
5. Securely hook the cable’s spring into the rear most hole of the respective actuator bracket.
6. Repeat the wheel drive and auger control tests to verify proper adjustment. Repeat previous steps if necessary to attain proper adjustment of each cable

### Gas & Oil Fill-Up



**WARNING!** Use extreme care when handling gasoline. Gasoline is extremely flammable and the vapors are explosive. Never fuel the machine indoors or while the engine is hot or running. Extinguish cigarettes, cigars, pipes and other sources of ignition.

Service the engine with gasoline and oil as instructed in the separate Engine Owner’s Manual included with this unit. Read those instructions carefully.

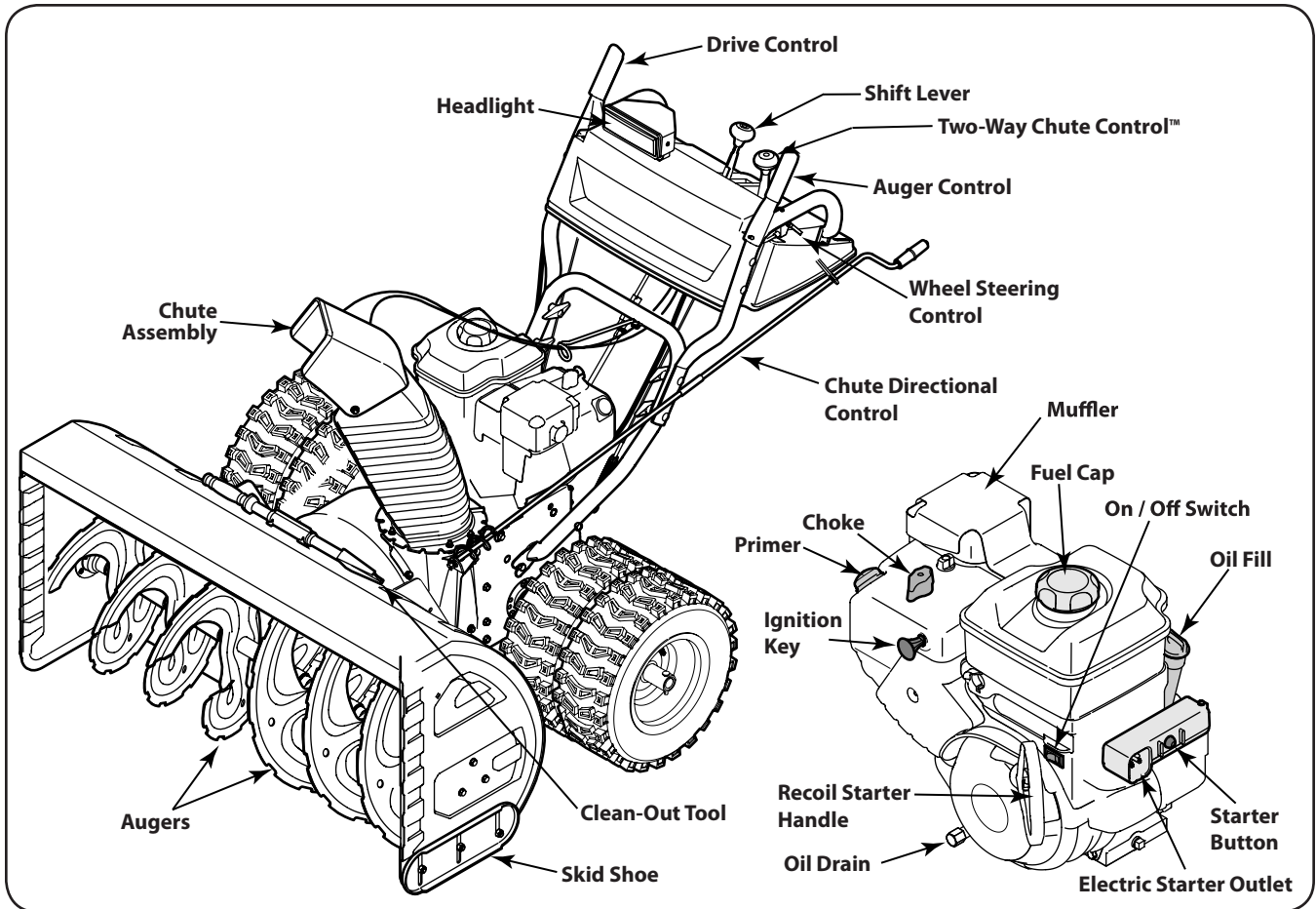

Figure 4-1

Snow thrower controls and features are described below and illustrated in Fig. 4-1.

**NOTE:** For detailed information on all engine controls, refer to the separate Briggs & Stratton Engine Operator's Manual.

### Shift Lever

The shift lever is located in the right side of the handle panel and is used to determine ground speed and direction of travel.

### Forward

There are six forward (F) speeds. Position one (1) is the slowest and position six (6) is the fastest.

### Reverse

There are two reverse (R) speeds. One (1) is the slower and two (2) is the faster.

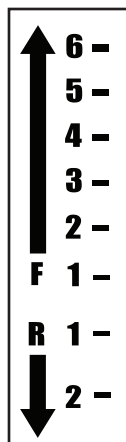

### Choke Control



The choke control is found on the top of the engine and is activated by rotating the knob clockwise. Activating the choke control closes the choke plate on the carburetor and aids in starting the engine.

### Ignition Key

The ignition key is a safety device. It must be fully inserted in order for the engine to start. Remove the ignition key when the snow thrower is not in use.

**Important:** Do not turn the ignition key in an attempt to start the engine. Doing so may cause it to break.

## Primer Bulb

Pressing the primer bulb forces fuel directly into the engine's carburetor to aid in starting a "Cold" engine.

**NOTE:** Do not use the primer bulb to restart a warm engine after a short shutdown.

## Oil Fill

Engine oil level can be checked and oil added through the oil fill.

## Skid Shoes

Position the skid shoes based on surface conditions. Adjust upward for hard-packed snow. Adjust downward when operating on gravel or crushed rock surfaces.

## Electric Starter Outlet

Requires the use of a three-prong outdoor extension cord and a 120V power source/wall outlet.

## Recoil Starter Handle

This handle is used to manually start the engine.

## Electric Starter Switch

Pressing the button on the top of the electric starter switch engages the engine's electric starter when plugged into a 120V power source.

## Augers

When engaged, the augers rotate and draw snow into the auger housing.

## Chute Assembly

Snow drawn into the auger housing is discharged out the chute assembly.

## Fuel Cap

Remove the gas cap to add gasoline to the fuel tank.

## Auger Control

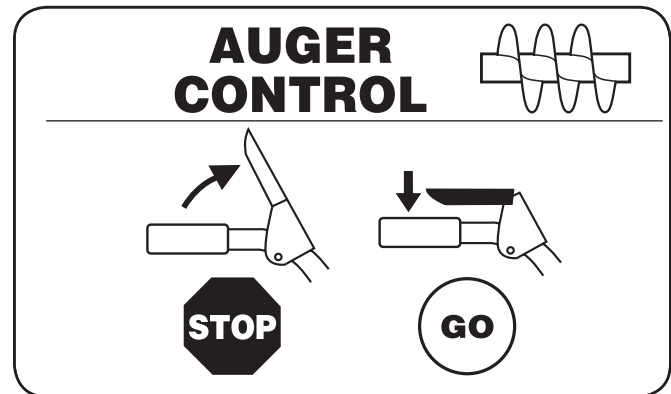

The auger control is located on the left handle. Squeeze the control grip against the handle to engage the augers and start snow throwing action. Release to stop.

## Drive Control / Auger Clutch Lock

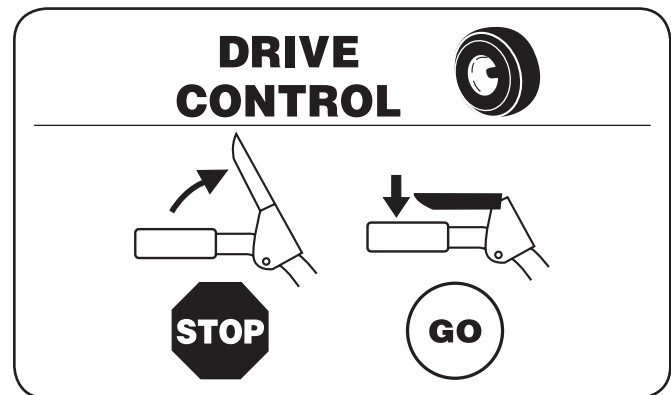

The drive control is located on the right handle. Squeeze the control grip against the handle to engage the wheel drive. Release the handle to stop.

The drive control also locks the auger control so that you can operate the chute directional control without interrupting the snow throwing process. If the auger control is engaged simultaneously with the drive control, the operator can release the auger control (on the left handle) and the augers will remain engaged. Release both controls to stop the augers and wheel drive.

**NOTE:** Always release the drive control before changing speeds. Failure to do so will result in increased wear on your machine's drive system.

## Two-Way Chute Control™

The two-way chute control is located on the left side of the dash panel and is used to control the distance of snow discharge from the chute.

- To change the upper chute angle to control the distance that snow is thrown, pivot the lever forward or backward.
- Move the lever forward to pivot the upper chute down and reduce the distance snow is thrown.

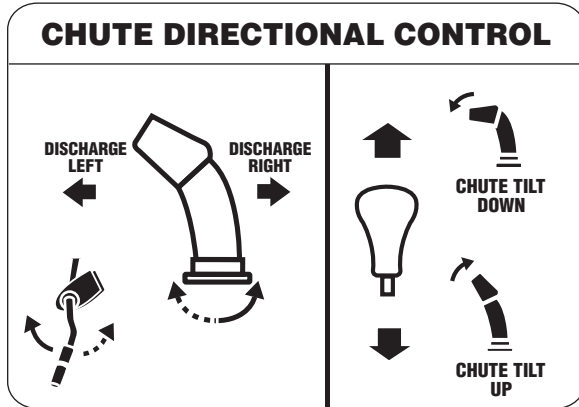

- Move the lever rearward to pivot the upper chute upward and increase the distance snow is thrown

## Chute Directional Control

The chute directional control is located on the left side of the snow thrower.

- To change the direction in which snow is thrown, crank clockwise to discharge to the left and counterclockwise to discharge to the right.

## Wheel Steering Controls

The left and right wheel steering controls are located on the underside of the handles. Squeeze the right control to turn right; squeeze the left control to turn left.

**NOTE:** Operate the snow thrower in open areas until you are familiar with these controls.

## Chute Clean-Out Tool



**WARNING!** Never use your hands to clear a clogged chute assembly. Shut off engine and remain behind handles until all moving parts have stopped before unclogging.

The chute clean-out tool is conveniently fastened to the rear of the auger housing with a mounting clip. Should snow and ice become lodged in the chute assembly during operation, proceed as follows to safely clean the chute assembly and chute opening:

1. Release both the Auger Control and the Drive Control.
2. Stop the engine by removing the ignition key.
3. Remove the clean-out tool from the clip which secures it to the rear of the auger housing.
4. Use the shovel-shaped end of the clean-out tool to dislodge and scoop any snow and ice which has formed in and near the chute assembly.
5. Refasten the clean-out tool to the mounting clip on the rear of the auger housing, reinsert the ignition key and start the snow thrower's engine.
6. While standing in the operator's position (behind the snow thrower), engage the auger control for a few seconds to clear any remaining snow and ice from the chute assembly.

## Head Light

It can be tilted by loosening the screws on the side of its housing, position the light in the desired location and then retighten the screws.

## Starting The Engine

1. Attach spark plug wire to spark plug. Make certain the metal loop on the end of the spark plug wire (inside the rubber boot) is fastened securely over the metal tip on the spark plug.
2. Make certain both the auger control and drive control are in the disengaged (released) position.
3. Insert ignition key into slot. Make sure it snaps into place. Do not attempt to turn the key.  
**NOTE:** The engine cannot start unless the key is inserted into ignition switch.
4. Position On/Off switch to "On" position.

## Electric Starter

Determine that your home's wiring is a three-wire grounded system. Ask a licensed electrician if you are not certain.



**WARNING!** The optional electric starter is equipped with a grounded three-wire power cord and plug, and is designed to operate on 120 volt AC household current. It must be used with a properly grounded three-prong receptacle at all times to avoid the possibility of electric shock. Follow all instructions carefully prior to operating the electric starter.

If you have a grounded three-prong receptacle, proceed as follows:

1. Plug the extension cord into the outlet located on the engine's surface. Plug the other end of extension cord into a three-prong 120-volt, grounded, AC outlet in a well-ventilated area.
2. Rotate choke control to FULL choke position (for a cold engine start).  
**NOTE:** If the engine is already warm, place choke control in the OFF position instead of FULL.
3. Push the primer two or three times for cold engine start, making sure to cover vent hole in the center of the primer when pushing.  
**NOTE:** DO NOT use primer to restart a warm engine after a short shutdown.
4. Push starter button to start engine. Once the engine starts, release starter button.  
**NOTE:** Do NOT hold the button down for longer than seven (7) seconds at a time. Doing so may damage your engine's electric starter.
5. As the engine warms, slowly rotate the choke control to the OFF position. If the engine falters, quickly rotate the choke control back toward FULL choke, and then slowly into the OFF position again.

6. When disconnecting the extension cord, always unplug the end at the three-prong wall outlet before unplugging the opposite end from the snow thrower.

## Recoil Starter

1. Rotate choke control to FULL choke position (cold engine start).  
**NOTE:** If the engine is already warm, place choke control in the OFF position instead of FULL.
2. Push the primer two or three times for cold engine start, making sure to cover vent hole in the center of the primer when pushing.  
**NOTE:** DO NOT use primer to restart a warm engine after a short shutdown.  
**NOTE:** Additional priming may be necessary if the temperature is below 15° Fahrenheit.
3. Grasp the recoil starter handle and slowly pull the rope out. At the point where it becomes slightly harder to pull the rope, stop pulling and allow the rope to slowly recoil.
4. Pull the starter handle with a firm, rapid stroke. Do not release the handle and allow it to snap back. Keep a firm hold on the starter handle and allow it to slowly recoil.
5. As the engine warms, slowly rotate the choke control to the OFF position. If the engine falters, quickly rotate the choke control back toward the FULL choke position, and then slowly into the OFF position again.  
**NOTE:** Allow the engine to warm up for a few minutes after starting. The engine will not develop full power until it reaches operating temperatures.

## Stopping The Engine

Run engine for a few minutes before stopping to help dry off any moisture on the engine.

1. Position On/Off switch to "Off" position.
2. Remove the ignition key and store in a safe place.
3. Wipe all snow and moisture from the area around the engine as well as the area in and around the drive control and auger control. Also, engage and release both controls several times.

## To Engage Drive

1. Move the shift lever into one of the six forward (F) positions or two reverse (R) positions. Select a speed appropriate for the snow conditions and a pace you're comfortable with.

**NOTE:** Use slower speeds in higher snow and/or until you are familiar with the snow thrower operation.

2. Squeeze the drive control against the handle the snow thrower will move. Release it and drive motion will stop.



**CAUTION:** Never move the shift lever without first releasing the wheel drive control. Doing so will cause premature wear on the drive system's friction wheel

3. To turn the snow thrower to the left or right, squeeze the respective wheel steering control. Refer to Figure 4-1.

## To Engage Augers

1. To engage the augers and start throwing snow, squeeze the auger control against the left handle. Release to stop the augers.
2. While the auger control is engaged, squeeze the drive control to engage the interlock mechanism and to drive the snow thrower. The interlock mechanism locks the auger control so you can turn the chute control without interrupting the snow throwing process.
3. Release the auger control; the interlock mechanism should keep the auger control engaged until the drive control is released.
4. Release the drive control to stop both the augers and the wheel drive. To stop the auger, both levers must be released.

## Operating Tips

**NOTE:** Allow the engine to warm up for a few minutes. The engine will not develop full power until it reaches operating temperature.



**WARNING!** The temperature of the muffler and the surrounding areas may exceed 150° F. Avoid these areas.

1. If possible, remove snow immediately after it falls.
2. Discharge snow downwind whenever possible.
3. Slightly overlap each previous path.
4. Set the skid shoes 1/4" below the shave plate for normal usage. Adjust them upward for hard-packed snow and downward when using on gravel or crushed rock.

## Replacing Shear Pins

Each of the six auger spiral assemblies are secured to the spiral shaft with a shear pin and cotter pin. If the auger should strike a foreign object or ice jam, the snow thrower is designed so that the pins may shear. If the augers will not turn, check to see if the pins have sheared. See Fig. 5-1.



**CAUTION:** Never replace the auger shear pins with anything other than OEM Part No. 738-04155 replacement shear pins. Any damage to the auger gearbox or other components as a result of failing to do so will NOT be covered by your snow thrower's warranty.



**WARNING!** Always turn off the snow thrower's engine and remove the key prior to replacing shear pins.

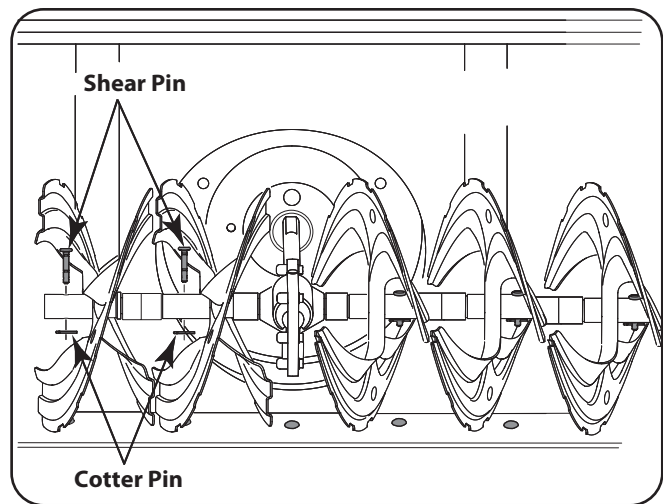

Figure 5-1

## Maintenance

### Engine

Refer to the Briggs & Stratton Engine manual packed with your machine for all engine maintenance.

### Shave Plate and Skid Shoes

The shave plate and skid shoes on the bottom of the snow thrower are subject to wear. They should be checked periodically and replaced when necessary.

**NOTE:** The skid shoes on this machine have two wear edges. When one side wears out, they can be rotated 180° to use the other edge.

To Remove skid shoes:

1. Remove the six carriage bolts, hex nuts, and bell washers that secure the two skid shoes to the sides of the auger housing. Refer to Figure 6-1.
2. Position the new skid shoes and secure with the carriage bolts, bell washers, and hex nuts. Make certain the skid shoes are adjusted to be level. See Figure 6-1.

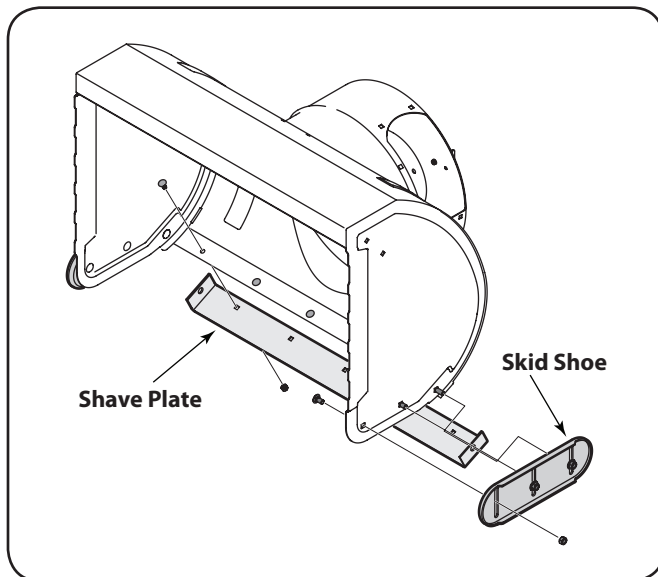

Figure 6-1

To replace shave plate:

1. Remove the hex nuts, bell washers, and carriage bolts that secure the shave plate to the bottom of the snow thrower housing.
2. Remove the rear most hex nut, bell washer, and carriage bolt securing the back of each skid shoe to the sides of the housing. Loosen the remaining hex nuts securing the skid shoes.
3. Slide the shave plate out of the off-set slot at the bottom of the housing, and from between the skid shoes and side panels of the housing.

4. With the mounting holes toward the back, slide the new shave plate into position and secure with the fasteners removed previously.

## Lubrication

### Gear Shaft

The gear (hex) shaft should be lubricated at least once a season or after every twenty-five (25) hours of operation.

1. Carefully pivot the snow thrower up and forward so that it rests on the auger housing.

**NOTE:** Before pivoting snow thrower up and forward, be sure to run the fuel tank dry to prevent leakage of fuel.

2. Remove the frame cover from the underside of the snow thrower by removing four self-tapping screws which secure it.
3. Apply a light coating of engine oil (or 3-in-1 oil) to the hex shaft. See Fig. 6-2.

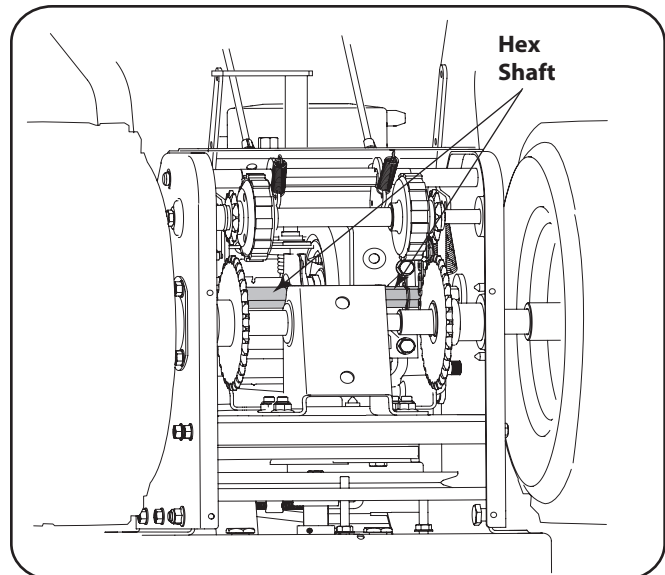

Figure 6-2

**NOTE:** When lubricating the hex shaft, be careful not to get any oil on the aluminum drive plate or the rubber friction wheel. Doing so will hinder the snow thrower's drive system. Wipe off any excess or spilled oil.

### Wheels

At least once a season, remove all four wheels. Clean and coat the axles with a multipurpose automotive grease before reinstalling wheels.

### Chute Directional Control

Once a season, lubricate the chute crank bracket bushing and the spiral with 3-in-1 oil.



## Auger Shaft

At least once a season, one at a time, remove the shear pins from the auger shaft. Spray lubricant inside the hub of each auger spiral assembly and around the spacers on the auger shaft.

Grease fittings can also be found at each end of the auger shaft. Lubricate flange bearings found at each end of the shaft with a grease gun once a season. See Figure 6-3.

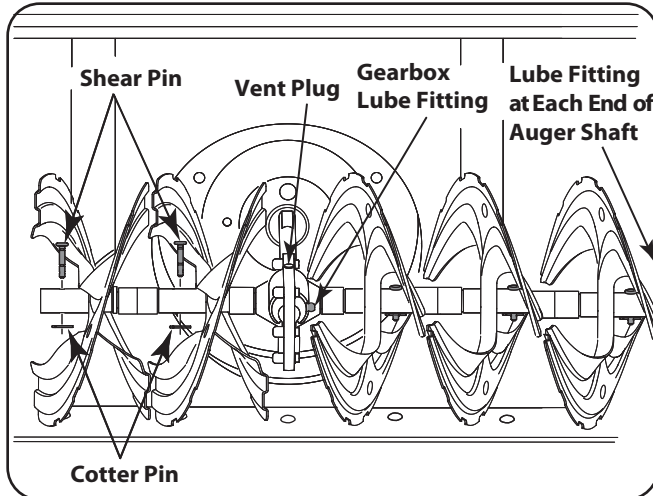

Figure 6-3

## Gear Case

The auger gear case is equipped with a grease fitting. Lubricate with Shell Alvania lead-free grease (737-0168) once a season. See Figure 6-3.

**NOTE:** To relieve pressure, remove the vent plug before lubricating the gear case. See Figure 6-3. Failure to do so could result in damage to the gear case seals.

## Augers

Each of the six auger spiral assemblies is secured to the spiral shaft with a shear pin and cotter pin. If the auger should strike a foreign object or ice jam, the snow thrower is designed so that the pins may shear.

1. If augers do not turn, check to see if pins have sheared.
2. Replace the pins if needed. Two replacement shear pins and cotter pins have been provided with the snow thrower. Spray an oil lubricant into shaft before inserting new pins and securing with new cotter pins.

## Adjustments

### Shift Rod

If the full range of speeds (forward and reverse) cannot be achieved, refer to the figure to Figure 6-4 and adjust the shift rod as follows:

1. Looking underneath the handle panel, note which of the three holes in the shift lever the ferrule is inserted into. Also note the direction of insertion. Then remove the internal cotter pin and flat washer from the ferrule and withdraw the ferrule from the shift lever. See Figure 6-4.
2. Place shift lever in sixth (6) position or fastest forward speed.
3. Push shift rod and shift arm assembly down sharply as far as it

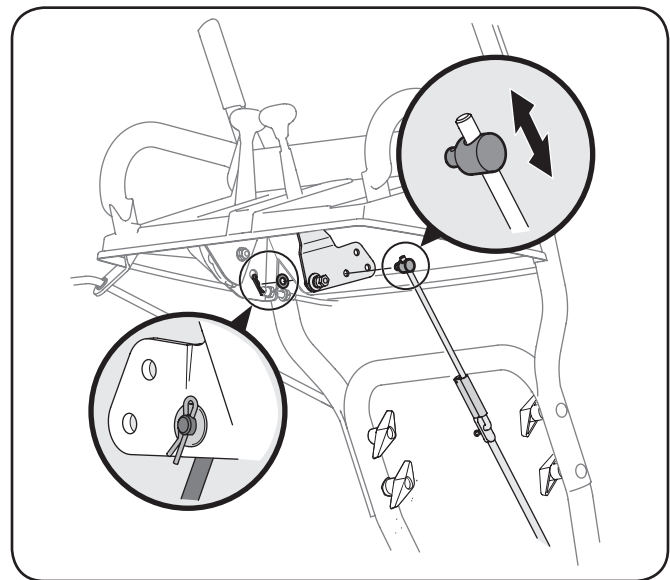

Figure 6-4

will go to shift the drive into the fastest forward position.

4. As necessary, rotate the ferrule up or down the shift rod until the ferrule lines up with the hole from which it was earlier removed. See Figure 6-4.
5. From the direction noted earlier, insert the ferrule into the proper hole. Reinstall the washer and secure with the internal cotter pin.

## Chute Bracket Adjustment

If the spiral at the bottom of the chute directional control is not fully engaging with the chute assembly, the chute bracket can be adjusted. To do so:

1. Loosen the two nuts which secure the chute bracket and reposition it slightly. Refer to Figure 6-5.
2. Retighten the nuts.

## Drive Control

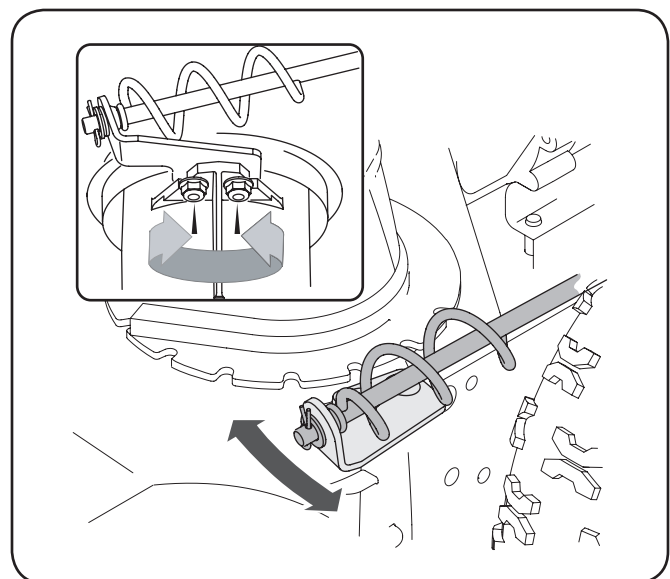

Figure 6-5

Refer to “Auger and Drive Control Cables” of the Assembly & Set-Up - Section 3 for instructions to adjust the drive control. To further check the adjustment, proceed as follows:

1. With the snow thrower tipped forward (be certain to drain gasoline or place plastic film under the gas cap if the snow thrower has already been operated), remove the frame cover underneath the snow thrower by removing the self-tapping screws. See Figure 6-6.
2. Locate the opening between the axle support bracket and the

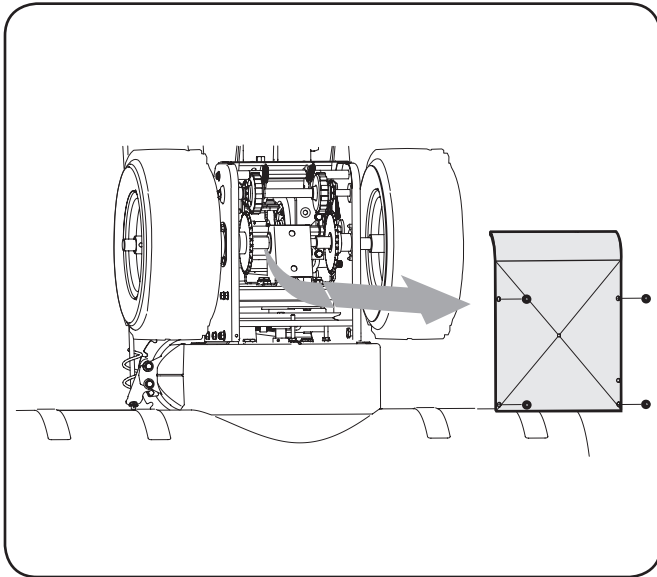

Figure 6-6

front frame support (See Figure 6-7). Looking through this opening, with the drive control released, there must be clearance between the friction wheel and the drive plate in all positions of the shift lever.

3. With the drive control engaged, the friction wheel must contact the drive plate. See Figure 6-7.

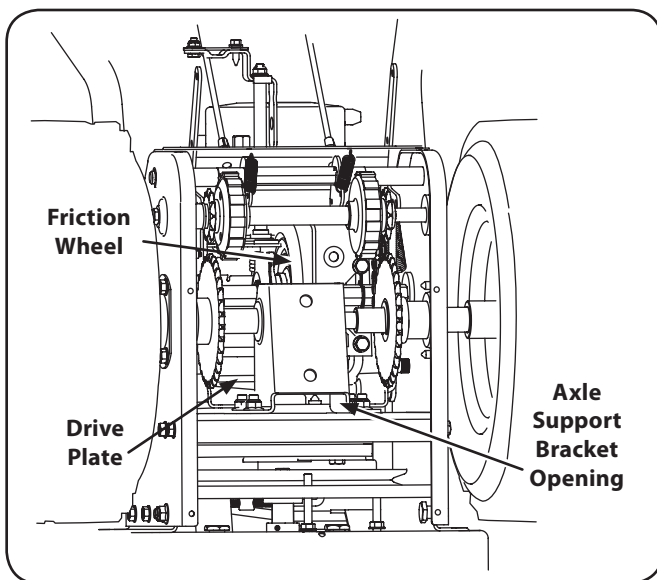

Figure 6-7

4. If there is no friction wheel clearance, or the friction wheel does not solidly contact the drive plate, re-adjust the lock nut on the lower end of the drive cable following the instructions in the Assembly section.
5. Reassemble the frame cover.

### Chute Directional Control

The distance snow is thrown can be adjusted by adjusting the angle of the chute assembly. Move the remote chute lever on the control panel forward to pivot the upper chute down; move the lever rearward to pivot the upper chute upward.

The chute directional control is located on the left side of the snow thrower. To change the direction in which snow is thrown, crank clockwise to discharge to the left and counterclockwise to discharge to the right.

### Auger Control

Refer to the Assembly and Set-up section for instructions on adjusting the auger control cable.

### Skid Shoes

Refer to the Assembly and Set-up section for instructions on adjusting the skid shoes.

### Tire Pressure

Refer to the tire sidewall for the manufacturer’s recommended tire air pressure. Keep the tires filled to the recommended psi. If the tire pressure is not equal in both tires, the unit may pull to one side or the other.

## Belt Replacement

### Belt Removal Preparation

1. Disconnect the chute crank assembly at the discharge chute end by removing the hairpin clip and the flat washer. Refer to Figure 7-1.

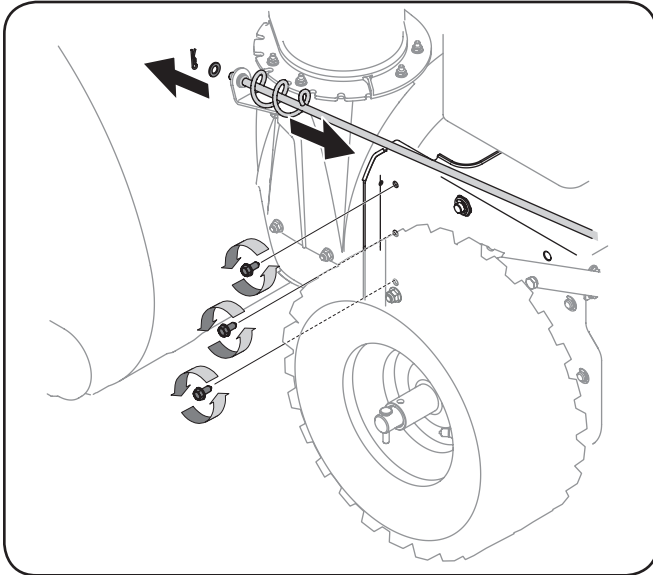

Figure 7-1

2. Remove the hex screws and lock nuts securing the forward end of the support tubes to the back of the auger housing, and pivot the tubes upward.
3. Remove the plastic belt cover on the front of the engine by removing the three self-tapping screws. See Figure 7-2.

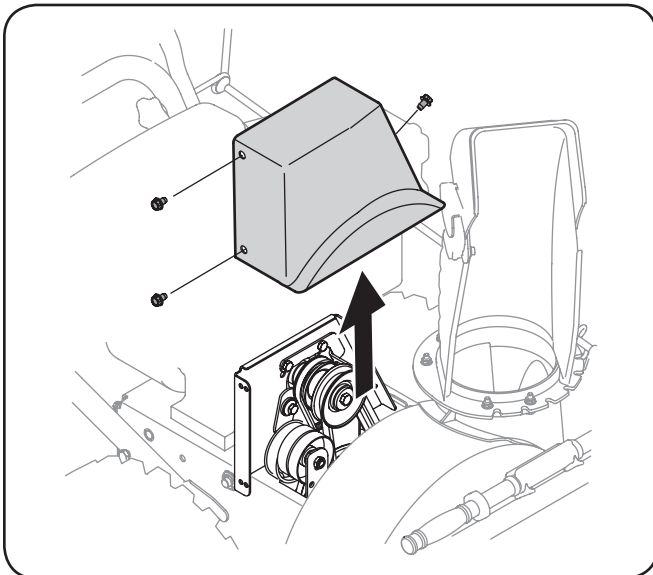

Figure 7-2

4. Loosen the bolt shown in Figure 7-3 securing the belt keeper bracket and remove the other bolt. Push the belt keeper bracket up off the engine pulley. Refer to Figure 7-3.

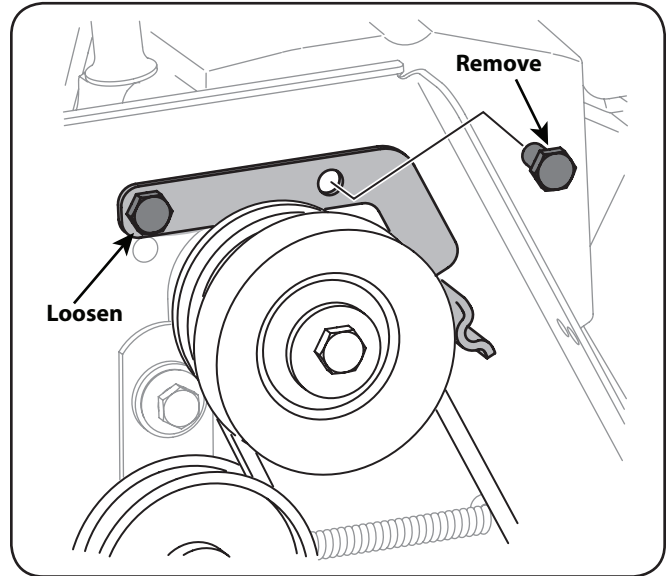

Figure 7-3

### Auger Belt Replacement

To remove and replace your snow thrower's auger belt, proceed as follows:

1. Remove the hairpin clip and flat washer from the ferrule in order to disconnect the auger idler rod from the brake bracket assembly. See Figure 7-4.

**NOTE:** Make sure to maintain the location of the ferrule on the idler rod.

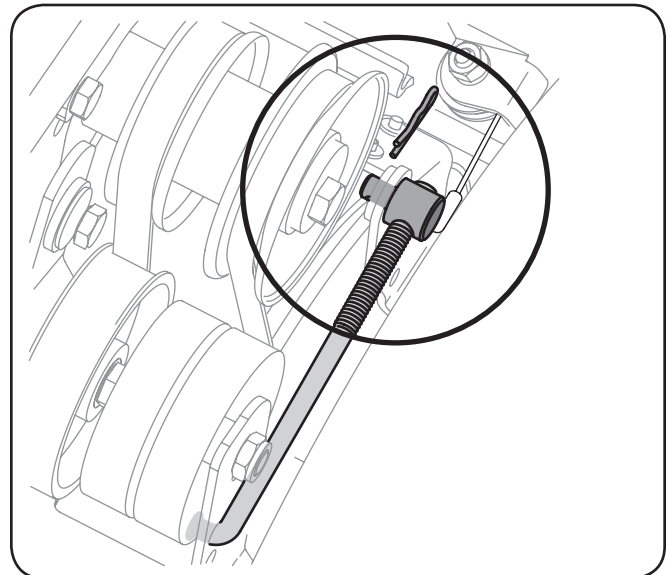

Figure 7-4

- Slip the auger control belt (the front belt) off the engine pulley.
- Pull the brake bracket assembly towards the cable guide roller and unhook the auger cable "Z" fitting. Refer to Figure 7-5.

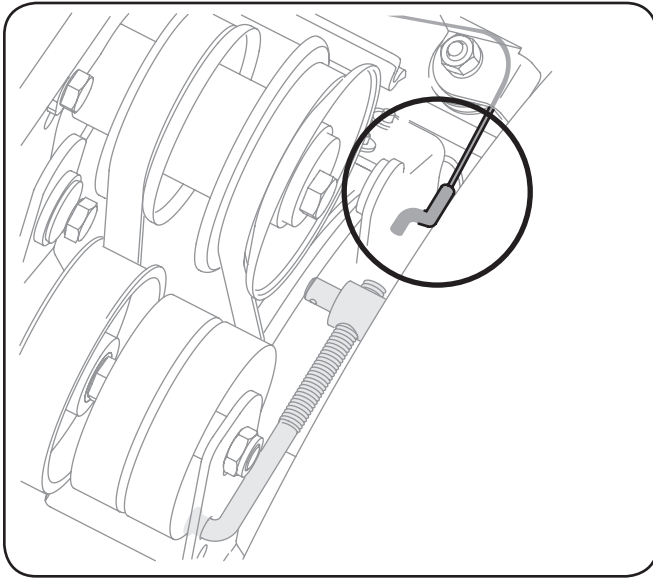

Figure 7-5

- From both sides of the frame assembly, use a 1/2" wrench to remove the three hex tap screws securing the transmission frame to the auger housing assembly. Refer to Figure 7-1. **NOTE:** Do not remove the lower hex flange lock nut on each side.
- Place a block of wood underneath the auger housing as shown in Figure 7-6 and separate auger housing from the transmission frame by tilting the housing forward and pulling up the handles.

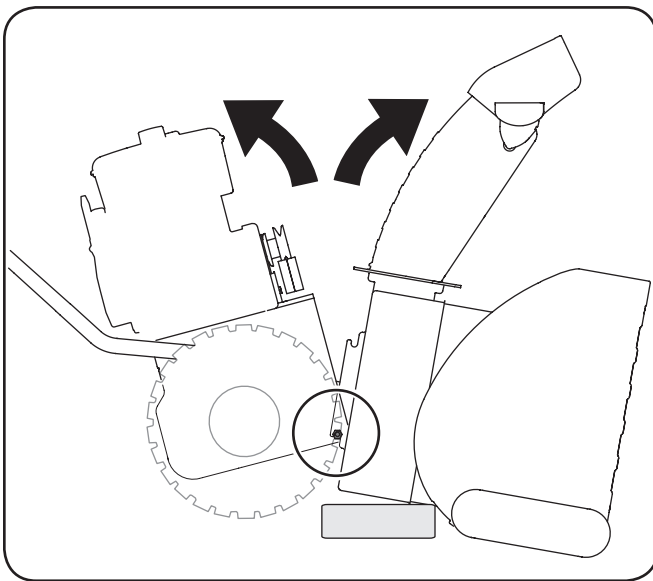

Figure 7-6

- Block the impeller with a piece of wood to prevent from spinning and use a 1/2" wrench to remove the hex screw and flat washer from the center of the auger input shaft and auger pulley adapter. Refer to Figure 7-7.

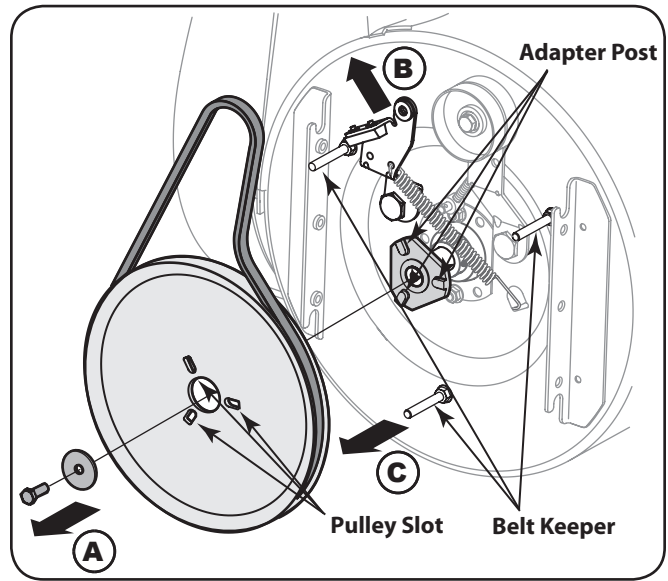

Figure 7-7

- Lift the brake bracket assembly out of the pulley groove and slide the pulley assembly off the posts of the auger pulley adapter to remove the old belt. Refer to Figure 7-7.

**NOTE:** The pulley adapter may slide off the auger input shaft when removing the pulley. Use extra caution to ensure the adapter does not fall and get damaged when removing the pulley.

- Place the new auger belt in the V-groove of the auger pulley and place the pulley w/belt inside the belt keepers.
  - Turn the pulley as necessary to align its three slots approximately with the posts of the pulley adapter, then move the brake bracket assembly away from the input shaft. While aligning the pulley slots and adapter posts, push the auger pulley fully onto the adapter. Refer to Figure 7-7.
- NOTE:** If the pulley adapter was removed with the pulley, align the splines of the pulley adapter and auger input shaft, and push the pulley and adapter onto the input shaft. Refer to Figure 7-7.
- Slide the washer onto the hex screw removed earlier and apply Loctite 262 to the threads of the hex screw.
  - Insert the hex screw through the pulley assembly and into the threads of the input shaft. Torque the hex screw to 250-325 in. /lbs. to secure the auger pulley assembly on the input shaft.

- If also replacing the drive belt, proceed to the "Drive Belt" instruction. If not, reposition the transmission frame back onto the auger housing. Install the drive belt on the engine pulley, re-connect the auger cable "Z" fitting and auger idler rod ferrule to the brake bracket. Reposition and secure the engine pulley belt guard, and re-install the belt cover.

**NOTE:** Make sure to remove the piece of wood blocking the impeller.

Check the auger drive belt adjustment. With the auger clutch lever in the disengaged position, the top surface of the new belt should be even with the outside diameter of the pulley.

To adjust, disconnect ferrule from brake bracket assembly. Thread ferrule in (towards idler) to increase tension on belt, or out to decrease belt tension.

**NOTE:** The brake puck must always be firmly seated in the pulley groove when auger control is disengaged.



**CAUTION:** Repeat the "Testing Auger Drive Control" from the Assembly and Set-up section before operating the snow thrower.

### Drive Belt Replacement

If not already done, remove the auger drive belt from the front pulley of the engine double pulley. Refer to "Auger Belt Replacement" instructions in the previous sub-section.

- Pull the idler pulley away from the backside of the drive belt to relieve the tension and slip the drive belt off the idler pulley. Carefully release the idler pulley. See Figure 7-8.

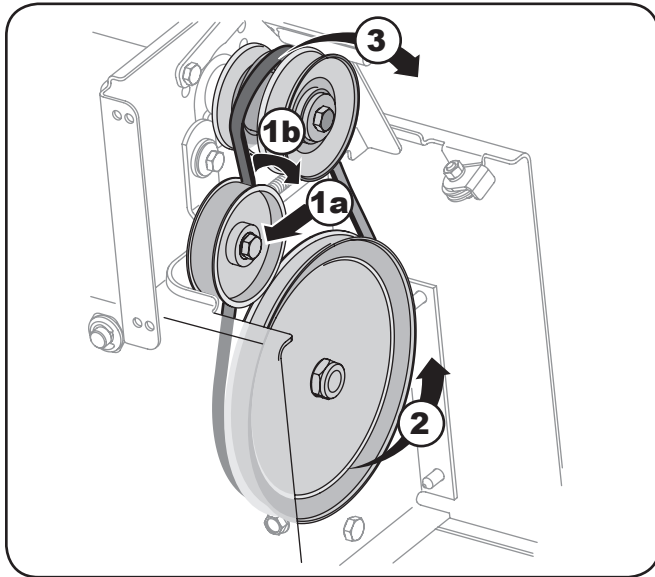

Figure 7-8

- Roll the drive belt off the lower drive pulley and then remove the belt from the engine pulley.

- Install the new belt on the pulleys in the reverse order and re-tension with the idler pulley.
- Reassemble by performing the previous steps in the opposite order and manner of removal.

### Changing Friction Wheel

The rubber on the friction wheel is subject to wear and should be checked periodically. Replace the friction wheel if any signs of wear or cracking are found.

- Drain the gasoline from the snow thrower, or run the fuel tank dry to prevent a hazardous situation.
- Tip the snow thrower up and forward, so that it rests on the housing.
- Remove screws from the frame cover underneath the snow thrower (refer to Figure 7-9). Remove the right wheels from the axle.

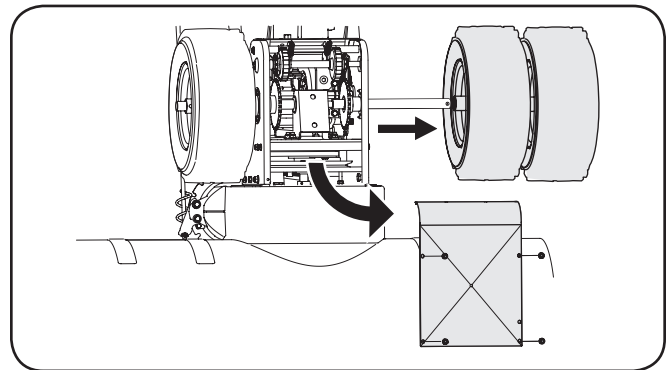

Figure 7-9

- Using a 3/4" wrench, hold the hex shaft and remove the hex screw and belleville washer and bearing from left side of the frame. Refer to Figure 7-10.

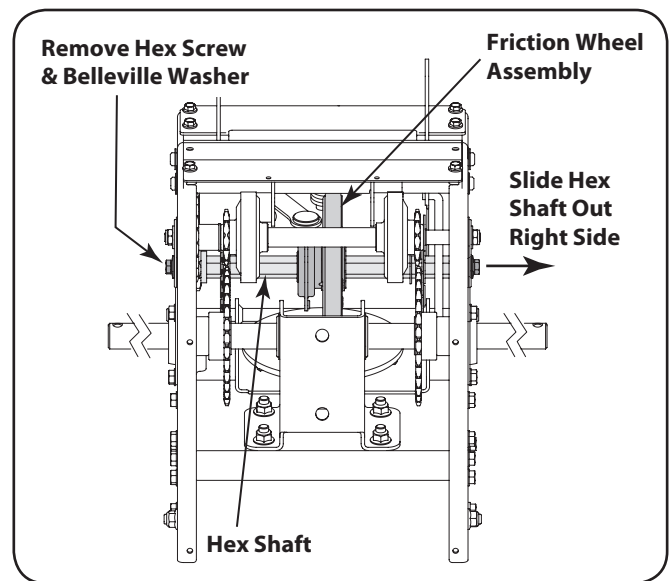
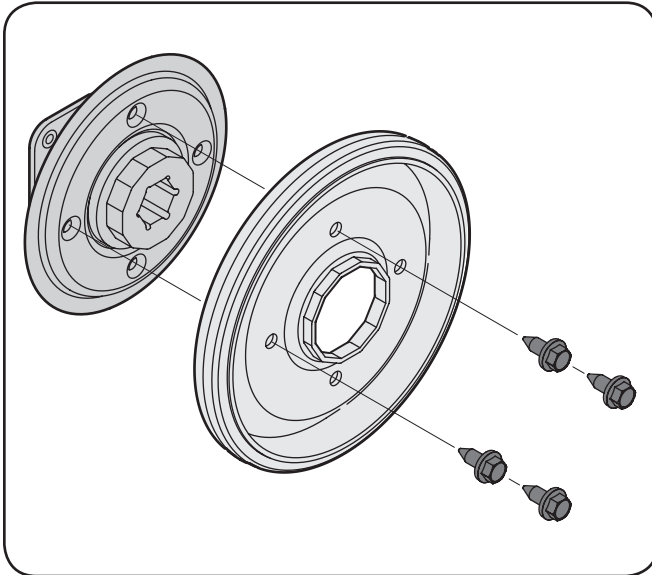

Figure 7-10

5. Holding the friction wheel assembly, slide the hex shaft out of the right side of the frame. The spacer on the left side of the hex shaft will fall and the sprocket should remain hanging loose in the chain.
6. Lift the friction wheel assembly out between the axle shaft and the drive shaft assemblies.
7. Remove four screws securing the friction wheel to the hub assembly (refer to Figure 7-11). Discard old friction wheel.



**Figure 7-11**

8. Reassemble the new friction wheel onto the hub assembly, tightening the four screws in rotation and with equal force. It is important to assemble the friction wheel symmetrically for proper functioning. Refer to Figure 7-11.
  9. Reposition the friction wheel assembly in the snow thrower frame. Insert the pin from the shift arm assembly into the friction wheel assembly and hold assembly in position. Refer to Figure 7-12.
  10. Slide the hex shaft through the right side of the frame toward the left side and through the friction wheel assembly.
- NOTE:** If the sprocket fell from the snow thrower chain while removing the hex shaft, position the hex hub of the sprocket toward the friction wheel and place the sprocket in the chain.
11. After making certain that the chain is on both the large and the small sprocket, align the hex shaft with the hex hub of the small sprocket, and slide the shaft through the sprocket.
  12. Slide the spacer onto the end of the hex shaft.
  13. Align the bearing on the right end of the hex shaft with the hole in the right side of the frame, then push the hex shaft to the left into position in the frame.

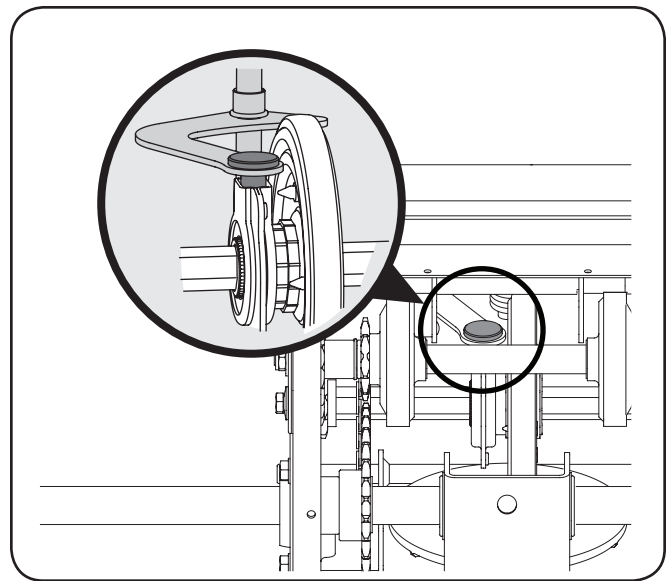

**Figure 7-12**

14. Slide the bearing onto the left end of the hex shaft and press into the hole on the left side the frame.
15. Place the belleville washer (rounded side toward head) onto the hex screw removed earlier, and insert the screw into the threaded hole of the hex shaft.
16. Gradually tighten the hex screw to fully seat the bearings in each side of the frame and to secure the hex shaft.
17. Position the frame cover on the bottom of the frame and secure with the self-tapping screws. Pivot the snow thrower down to its normal operating position.

## Off-Season Storage

If the snow thrower will not be used for 30 days or longer, the equipment needs to be stored properly. Follow storage instructions below to ensure top performance from the snow thrower for many more years.

**NOTE:** Refer to the engine manual for more detailed information on preparing the snow thrower engine for storage.

### Short-Term Storage

It is important to prevent gum deposits from forming in essential fuel system parts of the engine such as the carburetor, fuel filter, fuel hose, or tank during short-term storage (15-30 days). To prevent this, treat the fuel system using a fuel stabilizer.

Fuel stabilizer (such as STA-BIL™ or ULTRA-FRESH™) is an acceptable alternative in minimizing the formation of fuel gum deposits during storage. Add stabilizer to gasoline in fuel tank or storage container. Always follow mix ratio found on stabilizer container. Run engine at least 10 minutes after adding stabilizer to allow it to reach the carburetor.



**WARNING!** Never store snow thrower with fuel in tank indoors or in poorly ventilated areas, where fuel fumes may reach an open flame, spark or pilot light as on a furnace, water heater, clothes dryer or gas appliance.

### Long-Term Storage

To avoid engine problems, the fuel system should be emptied before storage for 30 days or longer.

1. Run the engine until the fuel tank is empty and it stops due to lack of fuel. Do not attempt to pour fuel from the engine.
2. Remove the spark plug and pour one (1) ounce of engine oil through the spark plug hole into the cylinder. Cover spark plug hole with a rag and crank the engine several times to distribute the oil. Replace spark plug.





**WARNING!** Never use engine or carburetor cleaning products in the fuel tank or permanent damage may occur.

Problem	Cause	Remedy
Engine fails to start	<ol style="list-style-type: none"> <li>1. Choke control not in ON position.</li> <li>2. Spark plug wire disconnected.</li> <li>3. Fuel tank empty or stale fuel.</li> <li>4. Engine not primed.</li> <li>5. Faulty spark plug.</li> <li>6. Safety key not inserted .</li> </ol>	<ol style="list-style-type: none"> <li>1. Move choke control to ON position.</li> <li>2. Connect wire to spark plug.</li> <li>3. Fill tank with clean, fresh gasoline.</li> <li>4. Prime engine as instructed in the Operation section.</li> <li>5. Clean, adjust gap, or replace spark plug.</li> <li>6. Insert key fully into the switch.</li> </ol>
Engine runs erratic	<ol style="list-style-type: none"> <li>1. Engine running on CHOKE.</li> <li>2. Stale fuel.</li> <li>3. Water or dirt in fuel system.</li> <li>4. Carburetor out of adjustment.</li> </ol>	<ol style="list-style-type: none"> <li>1. Move choke control to OFF position.</li> <li>2. Fill tank with clean, fresh gasoline.</li> <li>3. Drain fuel tank. Refill with fresh fuel.</li> <li>4. Contact a Briggs &amp; Stratton Engine Service Center.</li> </ol>
Engine overheats	<ol style="list-style-type: none"> <li>1. Carburetor not adjusted properly.</li> </ol>	<ol style="list-style-type: none"> <li>1. Contact a Briggs &amp; Stratton Engine Service Center.</li> </ol>
Excessive vibration	<ol style="list-style-type: none"> <li>1. Loose parts or damaged auger.</li> </ol>	<ol style="list-style-type: none"> <li>1. Stop engine immediately and disconnect spark plug wire. Tighten all bolts and nuts. If vibration continues, have unit serviced by an authorized Service Center.</li> </ol>
Loss of power	<ol style="list-style-type: none"> <li>1. Spark plug wire loose.</li> <li>2. Gas cap vent hole plugged.</li> </ol>	<ol style="list-style-type: none"> <li>1. Connect spark plug wire.</li> <li>2. Remove ice and snow from gas cap. Be certain vent hole is clear.</li> </ol>
Unit fails to propel itself	<ol style="list-style-type: none"> <li>1. Drive control cable in need of adjustment.</li> <li>2. Drive belt loose or damaged.</li> <li>3. Friction wheel worn.</li> </ol>	<ol style="list-style-type: none"> <li>1. Adjust drive control cable. Refer to Maintenance &amp; Adjustments section.</li> <li>2. Replace drive belt. Refer to Service section</li> <li>3. Replace friction wheel.</li> </ol>
Unit fails to discharge snow	<ol style="list-style-type: none"> <li>1. Chute assembly clogged.</li> <li>2. Foreign object lodged in auger.</li> <li>3. Auger control cable in need of adjustment.</li> <li>4. Auger belt loose or damaged.</li> <li>5. Shear pin(s) sheared.</li> </ol>	<ol style="list-style-type: none"> <li>1. Stop engine immediately and disconnect spark plug wire. Clean chute assembly and inside of auger housing with clean-out tool or a stick.</li> <li>2. Stop engine immediately and disconnect spark plug wire. Remove object from auger with clean-out tool or a stick.</li> <li>3. Adjust auger control cable. Refer to Assembly &amp; Set-Up section.</li> <li>4. Replace auger belt refer to Service section.</li> <li>5. Replace shear pin(s).</li> </ol>

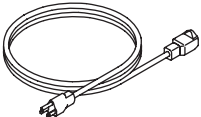
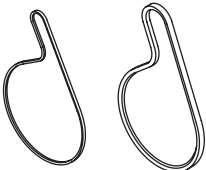
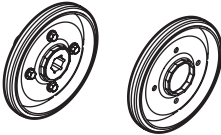
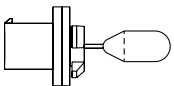
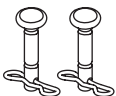
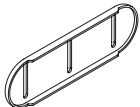
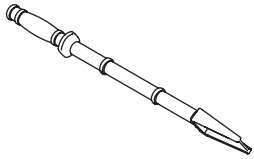
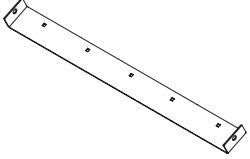

# Replacement Parts

# 9

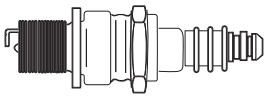
Component	Description	Part Number
	Extension Cord, 110V	929-0071
	Auger Drive Belt	954-04131
	Wheel Drive Belt	954-0367
	Friction Wheel Assembly	918-04178
	Friction Wheel w/Bonded Rubber	718-04034
	Halogen Lamp, 12V, (#890)	725-1658
	Shear Pin, 1.50	738-04155
	Bow-tie Cotter Pin	714-04040
	Stainless Steel Skid Shoe	790-00199
	Chute Clean-out Tool	731-2643
	Shave Plate, Stainless	790-00195A
	Key	BS-794696
	Champion® RC12YC	759-3336

Phone (800) 965-4CUB (4282) to order replacement parts or a complete Parts Manual (have your full model number and serial number ready). Parts Manual downloads are also available free of charge at [www.cubcadet.com](http://www.cubcadet.com).





---

## CUB CADET LLC MANUFACTURER'S LIMITED WARRANTY FOR SNOW THROWERS

The limited warranty set forth below is given by Cub Cadet LLC with respect to new merchandise purchased and used in the United States, its possessions and territories, and by MTD Products Limited with respect to new merchandise purchased and used in Canada and/or its territories and possessions.

**For non-commercial use:** Cub Cadet warrants this product (excluding *Normal Wear Parts*, as described below) against defects in material and workmanship for a period of three (3) years from the date of original retail purchase or lease.

**For commercial uses and applications:** Cub Cadet warrants this product (excluding *Normal Wear Parts*, as described below) against defects in material and workmanship for a period of one (1) year from the date of original retail purchase or lease.

"Cub Cadet" will, at its option, repair or replace, free of charge, any part found to be defective in materials or workmanship. This limited warranty shall only apply if this product has been operated and maintained in accordance with the Operator's Manual furnished with the product, and has not been subject to misuse, abuse, neglect, accident, improper maintenance, alteration, vandalism, theft, fire, water, or damage because of other peril or natural disaster. Damage resulting from the installation or use of any part, accessory or attachment not approved by Cub Cadet for use with the product(s) covered by this manual will void your warranty as to any resulting damage.

*Normal Wear Parts* are warranted to be free from defects in material and workmanship for a period of thirty (30) days from the date of purchase. Normal wear parts include, but are not limited to items such as: belts, skid shoes, shave plates and tires.

**HOW TO OBTAIN SERVICE:** Warranty service is available, WITH PROOF OF PURCHASE, through your local authorized service dealer. To locate the dealer in your area:

### **In the U.S.A.**

To locate the dealer in your area, check your Yellow Pages, or contact Cub Cadet LLC at P.O. Box 361131, Cleveland, Ohio 44136-0019, or call 1-877-282-8684, or log on to our Web site at [www.cubcadet.com](http://www.cubcadet.com).

### **In Canada**

Contact MTD Products Limited, Kitchener, ON N2G 4J1, or call 1-800-668-1238 or log on to our Web site at [www.mtdcanada.com](http://www.mtdcanada.com).

This limited warranty does not provide coverage in the following cases:

- a. The engine or component parts thereof. These items may carry a separate manufacturer's warranty. Refer to applicable manufacturer's warranty for terms and conditions.
- b. Routine maintenance items such as lubricants, filters, blade sharpening, tune-ups, brake adjustments, clutch adjustments, deck adjustments, and normal deterioration of the exterior finish due to use or exposure.

- c. Cub Cadet does not extend any warranty for products sold or exported outside of the United States and/or Canada, and their respective possessions and territories, except those sold through Cub Cadet's authorized channels of export distribution.
- d. Replacement parts that are not genuine Cub Cadet parts.
- e. Service completed by someone other than an authorized service dealer.
- f. Transportation charges and service calls.

**No implied warranty, including any implied warranty of merchantability of fitness for a particular purpose, applies after the applicable period of express written warranty above as to the parts as identified. No other express warranty, whether written or oral, except as mentioned above, given by any person or entity, including a dealer or retailer, with respect to any product, shall bind Cub Cadet. During the period of the warranty, the exclusive remedy is repair or replacement of the product as set forth above.**

**The provisions as set forth in this warranty provide the sole and exclusive remedy arising from the sale. Cub Cadet shall not be liable for incidental or consequential loss or damage including, without limitation, expenses incurred for substitute or replacement lawn care services or for rental expenses to temporarily replace a warranted product.**

Some states do not allow the exclusion or limitation of incidental or consequential damages, or limitations on how long an implied warranty lasts, so the above exclusions or limitations may not apply to you.

In no event shall recovery of any kind be greater than the amount of the purchase price of the product sold. **Alteration of safety features of the product shall void this warranty.** You assume the risk and liability for loss, damage, or injury to you and your property and/or to others and their property arising out of the misuse or inability to use the product.

This limited warranty shall not extend to anyone other than the original purchaser or to the person for whom it was purchased as a gift.

**HOW STATE LAW RELATES TO THIS WARRANTY:** This limited warranty gives you specific legal rights, and you may also have other rights that vary in different jurisdictions.

**IMPORTANT:** Owner must present Original Proof of Purchase to obtain warranty coverage.

**Cub Cadet LLC, P.O. BOX 361131 CLEVELAND, OHIO 44136-0019; Phone: 1-877-282-8684  
MTD Canada Limited - KITCHENER, ON N2G 4J1; Phone 1-800-668-1238**