

www.GELighting.com



GE Consumer Products
Lighting

 and General Electric are both registered trade marks of the General Electric Company, USA © General Electric Company (USA) 2003

ENT.CAT 02/2003

SHOWBIZ™ FOR STAGE, STUDIO, DISCO AND PHOTOGRAPHIC LIGHTING



GE Lighting

SHOWBIZ™

SHOWBIZ™ FOR STAGE, STUDIO, DISCO AND PHOTOGRAPHIC LIGHTING

Introduction

Welcome to this new updated catalogue. Under the SHOWBIZ™ brand GE Lighting will continue to be a leading supplier to the various sectors which make up the entertainment lighting industry.

GE Lighting have an ongoing strategy of product innovation and improvement to meet the demands and applications of O.E.M.s and end users.

This updated catalogue shows those lamps, from the extensive range of entertainment lighting products, which are currently in popular use. Please note the many new products including a more comprehensive range of discharge range.

Certain other USA manufactured lamp types may be available to special order. Please contact your local GE Lighting Sales Office for details.

Notes

- A Hemispherical shield in front of filament masking all direct light
- B Operate at or near horizontal
- C Protect from moisture. Safety screening techniques recommended
- D Replace broken lamp immediately. Inner bulb pressurised and could shatter unexpectedly
- E Use safety screen external to lamp
- F Operate BDTH
- G Operate BD $\pm 30^\circ$
- H 100V rating available to order
- J 120V rating available to order
- K Specially designed for searchlight applications
- L Twin filament lamp. Lumen figures relate to single and twin filament options
- M Tungsten Halogen minimum bulb wall temp 250°C
- N 3 or 4 amp HBC fuse necessary
- P 5 or 6 amp HBC fuse necessary
- Q 6 or 7 amp HBC fuse necessary
- R 10 amp HBC fuse necessary
- S Due to internal integral reflector nominal lumens not shown
- T Obscured top
- V Due to integral dichroic reflector nominal lumens not shown
- W Axial coiled coil single ended lamps will generally give better reliability against premature arcing if orientations in which the main support spine is under the filament are avoided

Contents

| | |
|-----------------------------|-----------|
| Symbols | 2 - 3 |
| PAR Lamps | 4 - 17 |
| Single Ended Halogen Lamps | 18 - 35 |
| Linear Halogen Lamps | 36 - 43 |
| Specialist Projector Lamps | 44 - 61 |
| Discharge Lamps | 62 - 81 |
| Technical Information | 82 - 117 |
| Index | 118 - 141 |
| GE Lighting World Addresses | 142 - 148 |

Symbols

| English | Français | Italiano | Español | Deutsch | English | Français | Italiano | Español | Deutsch |
|---|------------------------|----------------------------------|---------------------------------------|----------------------|--|---|--|---|---------------------------------|
| W Watts | Watt | Watt | Vatios | Nennleistung in Watt | A Length 1 | Longueur 1 | Lunghezza 1 | Longitud 1 | Länge 1 |
| V Volts | Volt | Volt | Voltios | Spannung in Volt | C Length 2 | Longueur 2 | Lunghezza 2 | Longitud 2 | Länge 2 |
| amp AMP | Courant (amp) | Corrente | Intensidad (A) | Strom (A) | B Diameter | Diamètre | Diametro | Diámetro | Durchmesser |
| OC Order Code | Code de Commande | Codice ordinazione | Código de pedido | Auftragscode | mm Gap (mm) | Distance (mm) | Distanza fra gli elettrodi (mm) | Distancia (mm) | Lichtbogenlänge |
| D Description | Description | Descrizione | Descripción | Beschreibung | + Filament Form | Forme du Filament | Forma filamento | Forma del filamento | Wendelausführung |
| Lightbulb Product Code | Code Produit | Codice prodotto | Código de producto | Produktcode | H Rated Life | Durée de Vie Moyenne | Durata nominale | Vida media | Lebensdauer |
| ANSI ANSI | ANSI | Codice ANSI | ANSI | ANSI-Code | H Life, burning position horizontal (hours) | Durée de vie, fonctionnement horizontal | Vita, posizione di funzionamento orizzontale | Vida, posición de funcionamiento horizontal | Mittlere Lebensdauer, Brennlage |
| LIF LIF | LIF | Codice LIF | LIF | LIF - Code | V Life, burning position vertical (hours) | Durée de vie, fonctionnement vertical | Vita, posizione di funzionamento verticale | Vida, posición de funcionamiento vertical | Mittlere Lebensdauer, Vertikal |
| A Primary Application | Application Principale | Applicazione principale | Aplicación básica | Erstanwendung | Cd Peak Intensity | Pic d'Intensité | Intensita' di picco | Intensidad máxima | Lichtstärke in cd |
| Cap Cap | Culot | Attacco | Casquillo | Socket | 10% Beam 10% | Faisceau 10% | Apertura del fascio al 10% del picco massimo | Haz 10% | Austrahlwinkel 10% |
| Lightbulb Bulb/Lamp | Ampoule | Forma /lampada | Lámpara/bulbo | Lampe | 50% Beam 50% | Faisceau 50% | Apertura del fascio al 50% del picco massimo | Haz 50% | Austrahlwinkel 50% |
| F Finish | Finition | Finitura | Acabado | Finish | 1/2 Angle 1/2 | Ouverture 50% de l'intensité max | Apertura al 50% dell'intensità massima | Angulo mitad de pico (grados) | Halbwerts-winkel |
| Lightbulb Working Distance /Focal Distance | Distance de Montage | Distanza Focale /Distancia focal | Distancia de trabajo /Distance Focale | Betriebsabstand | 1/10 Angle 1/10 | Ouverture 10% de l'intensité max | Apertura al 10% dell'intensità massima | Angulo décima parte de pico (grados) | Zehntwerts-winkel |

| English | Français | Italiano | Español | Deutsch | English | Français | Italiano | Español | Deutsch |
|--------------------------------------|----------------------------|---|--------------------------------|----------------------------|--------------------------------|-------------------------------|--------------------------------|-----------------------------|----------------------|
| HxW HxW | HxW | Apertura in Gradi (orizzontale x verticale) | HxW | HxW | RT Run up time (mins) | Temps de mise en régime (min) | Tempo di andata a regime (min) | Tiempo de arranque (min) | Anlaufzeit (min) |
| LM Initial Lumens | Lumens initiaux | Lumen iniziali | Lúmenes iniciales | Anfangslichtstrom in Lumen | RC Restrike time (mins) | Temps de Réamorçage (min) | Tempo di riaccensione (min) | Tiempo de reencendido (min) | Wiederzündzeit (min) |
| LM 100 Lumens 100hrs | Lumens 100Hres | Lumen 100 ore | Lúmenes 100 | Anfangslichtstrom (lm) | Wave Pulse | Fréquence | Impulso di accensione | Frecuencia | Impuls |
| % Lightbulb Lumen Maintenance | Maintenance de flux | Lumen | Mantenimiento de flujo | Lichtstromerhalt | RC Run up Current | Courant d'Amorçage | Corrente di avviamento | Corriente de arranque | Einschaltstrom |
| XY Chromaticity | Chromaticité | Coordinate cromatiche | Cromaticidad | Farbart | Ballast Ballast Choke | Ballast | Ballast | Balasto magnético | Drosselspule |
| Color Colour | Couleur | Colore | Color | Farbe | I Ignitor | Amorceur | Accenditore | Ignitor | Anzünden |
| K Colour Temperature | Température de Couleur | Temperatura colore | Temperatura de color | Farbtemperatur | Capacitor Capacitor | Capaciteur | Condensatore | Capacitador | Kondensator |
| CRI Ra | IRC | Índice di resa cromatica | Índice de resolución cromática | CRI | Pack Pack Quantity | Quantité par Emballage | Imballo pezzi | Unidad de embalaje | Verpackungseinheit |
| BP Burn Position | Position de Fonctionnement | Posizione di funzionamento | Posición de funcionamiento | Brennlage | FIG N° Figure Number | Numéro de schéma | Figura n. | Figura número | Fig. nummer |
| SO Starting Time (sec) | Temps d'Amorçage (sec) | Tempo di accensione (sec) | Tiempo de encendido (sec) | Startzeit (sec) | Notes Notes | Notes | Note | Notas | Bemerkung |

PAR Lamps

| | |
|-------------------------|---------|
| PAR 36 | 6 - 8 |
| PAR 46 | 9 - 10 |
| PAR 56 | 11 - 12 |
| PAR 64 | 13 - 17 |
| New Super PAR 64 | |

PAR lamps provide a robust and flexible design solution for a wide range of theatre, studio and nightclub applications.



Twister, Wilhelmshafen, Germany By Fischer Art of Light & Sound GmbH, Bremen

PAR 36



PAR 56



PAR 64



Lampes Par

Les lampes PAR sont une ressource flexible et robuste pour une large gamme d'applications dans les théâtres, les discothèques et les studios.

Lampade PAR

Le lampade PAR forniscono la possibilità di progettare soluzioni efficaci e flessibili per applicazioni in teatro, studio e locali notturni.

Lámparas PAR

Las lámparas PAR son una solución robusta y a la vez flexible cuando se realizan diseños de iluminación en todo tipo de teatros, escenarios, discotecas.

PAR Lampen

Par Lampen bieten eine robuste und flexible Designlösung für eine umfangreiche Anwendung an Theater-, Studio- und Nachtclub-Anwendungen.

PAR Lamps

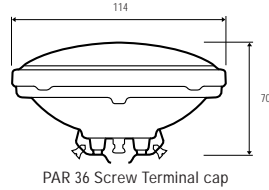
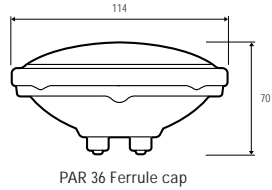

PAR 36 Ferrule cap

| W | V | OC | Cd | K | 10% | 50% | H | BC | Lightbulb | |
|-----|-----|-----|-------|------|-----|-------|-----|----|-----------|-------|
| 650 | 120 | FCW | - | 3200 | - | 60x55 | 100 | 12 | BC | 41672 |
| 650 | 120 | FCX | 24000 | 3200 | - | 40x30 | 100 | 12 | BC | 41673 |

PAR 36 Screw Terminal cap

| W | V | OC | Cd | K | 10% | 50% | H | BC | Lightbulb | |
|---------|------|---------------|--------|------|-----------|-------|------|----|-----------|-------|
| 0.5Amp | 4.7 | 4546 | 6300 | - | 3x3 | - | 1000 | 12 | - | 24780 |
| 12.5Amp | 4.75 | 4547 | 20000 | - | 3x3 | - | 100 | 12 | - | 24788 |
| 25 | 5.5 | 25PAR36 | 30000 | 3000 | 5.5x4.5 | - | 1000 | 12 | A | 14553 |
| 25 | 12 | 25PAR36/NSP | 4500 | - | 19x17 | 10x8 | 2000 | 12 | A | 14554 |
| 25 | 12 | 25PAR36/WFL | 500 | - | 49x41 | 37x26 | 2000 | 12 | A | 14555 |
| 25 | 12 | 25PAR36/VWFL | 250 | - | 82x80 | 40x33 | 2000 | 12 | A | 14556 |
| 30 | 12.8 | 4405 | 50000 | - | 6x5 | - | 100 | 12 | AD | 24425 |
| 30 | 6.2 | 4511 | 2300 | - | TRAPEZOID | - | 300 | 12 | - | 24663 |
| 30 | 6.4 | H4515 | 67000 | - | 5.5x4 | - | 100 | 12 | AD | 15133 |
| 30 | 6.4 | 4515 | 55000 | - | 5x5 | - | 100 | 12 | A | 24673 |
| 30 | 6.4 | H7604 | 100000 | - | 7x5 | - | 100 | 12 | - | 43576 |
| 30 | 6.2 | 4516 | 45000 | - | 9x4 | - | 300 | 12 | - | 24678 |
| 37.5 | 12.8 | H7616 | 70000 | - | 7x4 | - | 300 | 12 | A | 42838 |
| 50 | 12 | 50PAR36/VNSP | 25000 | - | 11x9 | - | 2000 | 12 | A | 12892 |
| 50 | 12 | 50PAR36/NSP | 9200 | - | 20x17 | 11x9 | 2000 | 12 | A | 16540 |
| 50 | 12 | 50PAR36/WFL | 1300 | - | 48x41 | 36x28 | 2000 | 12 | A | 16541 |
| 50 | 12 | 50PAR36/WFL/H | - | 3050 | - | - | 4000 | 12 | - | 19880 |
| 50 | 12 | 50PAR36/VWFL | 600 | - | 80x80 | 40x37 | 2000 | 12 | A | 16542 |
| 50 | 28 | 4502 | 10000 | - | 40x7 | - | 400 | 12 | - | 24627 |
| 50 | 28 | 4505 | 45000 | - | 11x5 | - | 400 | 12 | - | 24640 |
| 100 | 13 | 4509 | 110000 | - | 12x6 | - | 25 | 12 | - | 24650 |
| 100 | 13 | 4509X | 110000 | - | 12x6 | - | 25 | 12 | - | 41503 |
| 100 | 13 | 4595 | 60000 | - | 14x16 | - | 300 | 12 | - | 24892 |
| 100 | 28 | 4591 | 90000 | - | 12x6 | - | 25 | 12 | - | 24882 |

PAR Lamps continued

PAR 36 Screw Terminal cap continued

| W | V | OC | Cd | K | 10% | 50% | H | | | | |
|-----|-----|------|--------|------|-------|-------|-----|----|----|-------|--|
| 50 | 28 | 4593 | 1500 | - | 80x30 | - | 400 | 12 | - | 24887 | |
| 100 | 28 | 4594 | 70000 | - | 13x7 | - | 300 | 12 | BC | 24891 | |
| 150 | 28 | 4626 | 25000 | - | 40x9 | - | 300 | 12 | - | 24964 | |
| 150 | 28 | 4627 | 3000 | - | 80x30 | - | 300 | 12 | - | 24966 | |
| 250 | 28 | 4587 | 4000 | - | 40x13 | - | 25 | 12 | - | 24867 | |
| 250 | 28 | 4596 | 150000 | 3000 | 11x12 | - | 25 | 12 | - | 24898 | |
| 650 | 120 | DWE | 24000 | 3200 | - | 40x30 | 100 | 12 | BC | 41667 | |
| 650 | 120 | FBE | 35000 | 5000 | - | 25x15 | 35 | 12 | BC | 41669 | |
| 650 | 120 | FBO | 75000 | 3400 | - | 25x15 | 30 | 12 | BC | 41671 | |

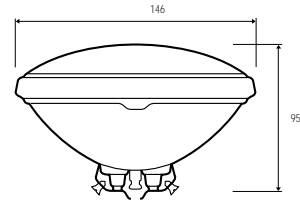

PAR 46 Screw Terminal cap

| W | V | OC | Cd | K | 10% | 50% | H | | | | |
|-----|------|--------|--------|---|-------|-----|------|----|---|-------|--|
| 30 | 6.4 | 4535 | 95000 | - | 5.5x4 | - | 100 | 12 | A | 24735 | |
| 30 | 12.8 | 4435 | 75000 | - | 5x5 | - | 300 | 12 | A | 24577 | |
| 40 | 12.5 | 4531 | 30000 | - | 20x5 | - | 400 | 12 | - | 24726 | |
| 50 | 12.8 | H7635 | 160000 | - | 6.5x4 | - | 100 | 12 | D | 43591 | |
| 100 | 13 | 4537-2 | 200000 | - | 11x16 | - | 25 | 12 | - | 40822 | |
| 100 | 13 | 4537 | 200000 | - | 11x6 | - | 25 | 12 | - | 24742 | |
| 150 | 28 | 4570 | 32000 | - | 50x9 | - | 300 | 12 | - | 24828 | |
| 150 | 28 | 4571 | 7000 | - | 80x25 | - | 300 | 12 | - | 24830 | |
| 150 | 28 | 4572 | 4500 | - | 55x55 | - | 300 | 12 | - | 24833 | |
| 250 | 28 | 4551 | 75000 | - | 50x10 | - | 25 | 12 | - | 24795 | |
| 250 | 28 | 4553 | 300000 | - | 11x12 | - | 25 | 12 | E | 24799 | |
| 450 | 28 | 4580 | 400000 | - | 13x14 | - | 10 | 12 | - | 24859 | |
| 450 | 28 | 4581 | 400000 | - | 13x14 | - | 10 | 12 | - | 24862 | |
| 450 | 16.5 | 4635 | 325000 | - | 14x15 | - | 25 | 12 | - | 33284 | |
| 450 | 28 | Q4554 | 65000 | - | 50x11 | - | 25 | 12 | - | 37706 | |
| 450 | 28 | Q4597 | 16000 | - | 60x35 | - | 1000 | 12 | - | 37372 | |
| 450 | 28 | Q4681 | 310000 | - | 15x9 | - | 50 | 12 | - | 36271 | |

PAR Lamps continued

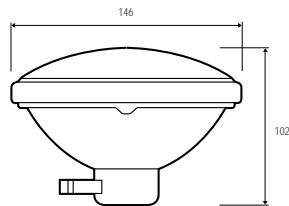

PAR 46 Medium Side Prong cap



| W | V | OC | Cd | K | 10% | 50% | H | E | Lightbulb | |
|-----|-----|---------------|-------|------|-------|-------|------|----|-----------|-------|
| 150 | 125 | 150PAR46/3MFL | 8000 | 2750 | 39x25 | 26x13 | 2000 | 12 | E | 41968 |
| 200 | 120 | 200PAR46/3MFL | 11500 | 2750 | 40x24 | 27x13 | 2000 | 12 | E | 20138 |

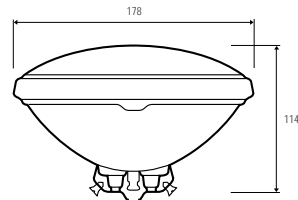

PAR 56 Screw Terminal cap



| W | V | OC | Cd | K | 10% | 50% | H | E | Lightbulb | |
|-----|----|---------------|--------|---|-------|-------|------|----|-----------|-------|
| 100 | 12 | 4545 | 225000 | - | 9x5 | - | 100 | 12 | A | 24768 |
| 120 | 12 | 120PAR56/VNSP | 60000 | - | 15x10 | 8x6 | 2000 | 12 | - | 19023 |
| 120 | 12 | 120PAR56/MFL | 19000 | - | 29x15 | 18x9 | 2000 | 12 | - | 19024 |
| 120 | 12 | 120PAR56/WFL | 5625 | - | 50x25 | 35x18 | 2000 | 12 | - | 19025 |
| 200 | 30 | 200PAR | 270000 | - | 9x9 | - | 500 | 12 | - | 20122 |
| 240 | 12 | 240PAR56/VNSP | 140000 | - | 7x10 | 9x6 | 2000 | 12 | C | 20575 |
| 240 | 12 | 240PAR56/MFL | 46000 | - | 28x15 | 18x9 | 2000 | 12 | C | 20576 |
| 240 | 12 | 240PAR56/WFL | 13000 | - | 50x27 | 35x18 | 2000 | 12 | C | 20577 |
| 300 | 12 | 300PAR56/WFL | - | - | - | - | 1000 | 12 | - | 23427 |

PAR Lamps continued

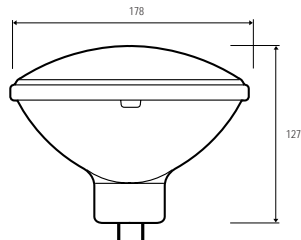

PAR 56 GX16d cap

| W | V | OC | Cd | K | 10% | 50% | H | □ | □ | □ | □ |
|-----|-----|---------------|-------|------|-------|-------|------|----|----|-------|---|
| 300 | 120 | 300PAR56/NSP | 68000 | 2750 | 20x14 | 10x8 | 2000 | 12 | C | 20803 | |
| 300 | 120 | 300PAR56/MFL | 24000 | 2750 | 34x19 | 23x11 | 2000 | 12 | C | 20836 | |
| 300 | 120 | 300PAR56/WFL | 11000 | 2750 | 57x27 | 37x18 | 2000 | 12 | C | 20849 | |
| 300 | 230 | 300PAR56/NSP | 40000 | - | - | - | 2000 | 12 | C | 20853 | |
| 300 | 230 | 300PAR56/MFL | 30000 | - | - | - | 2000 | 12 | C | 20852 | |
| 300 | 230 | 300PAR56/WFL | 10000 | - | - | - | 2000 | 12 | C | 20854 | |
| 300 | 240 | 300PAR56/NSP | 40000 | - | - | - | 2000 | 12 | C | 18676 | |
| 300 | 240 | 300PAR56/MFL | 30000 | - | - | - | 2000 | 12 | C | 18677 | |
| 300 | 240 | 300PAR56/WFL | 10000 | - | - | - | 2000 | 12 | C | 18678 | |
| 500 | 120 | Q500PAR56/NSP | 96000 | 2950 | 32x15 | 13x8 | 4000 | 6 | CD | 43494 | |
| 500 | 120 | Q500PAR56/MFL | 43000 | 2950 | 42x20 | 26x10 | 4000 | 6 | CD | 43495 | |
| 500 | 120 | Q500PAR56/WFL | 19000 | 2950 | 66x34 | 44x20 | 4000 | 6 | CD | 43496 | |

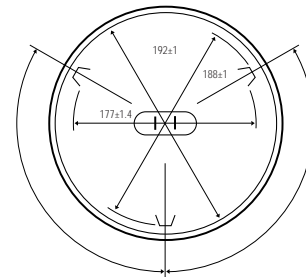
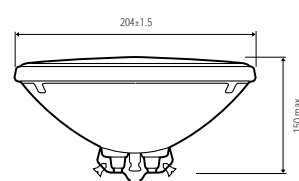

PAR 64 Screw Terminal cap

| W | V | OC | Cd | K | 10% | 50% | H | □ | □ | □ | □ |
|-----|----|--------|--------|---|--------|-----|-----|----|----|-------|---|
| 250 | 28 | 4552 | 500000 | - | 8x7 | - | 25 | 12 | - | 40576 | |
| 600 | 28 | 4559 | 600000 | - | 11x12 | - | 25 | 12 | C | 40578 | |
| 600 | 28 | Q4559 | 600000 | - | 12x8 | - | 100 | 12 | CD | 40579 | |
| 600 | 28 | Q4559X | 765000 | - | 11x7.5 | - | 100 | 12 | CD | 42552 | |

PAR Lamps continued

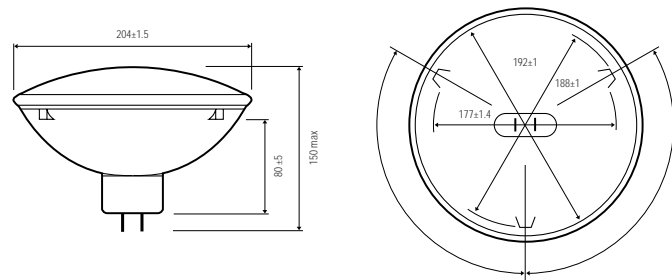

PAR 64 GX16d base (EMEP)



| | | | | | | | | | | | | |
|------------|------|------|----------------|---------------|--------|-------|--------|-------|-----|----|-------|-------|
| 500 | 230 | CP86 | Q500PAR64/VNSP | 240000 | 3200 | 16x13 | 10x7 | 300 | 6 | CD | 30280 | |
| 500 | 240 | CP86 | Q500PAR64/VNSP | 240000 | 3200 | 16x13 | 10x7 | 300 | 6 | CD | 30282 | |
| 500 | 230 | CP87 | Q500PAR64/NSP | 140000 | 3200 | 19x16 | 11x9 | 300 | 6 | CD | 30283 | |
| 500 | 240 | CP87 | Q500PAR64/NSP | 140000 | 3200 | 19x16 | 11x9 | 300 | 6 | CD | 30286 | |
| 500 | 230 | CP88 | Q500PAR64/MFL | 65000 | 3200 | 32x19 | 21x10 | 300 | 6 | CD | 30287 | |
| 500 | 240 | CP88 | Q500PAR64/MFL | 65000 | 3200 | 32x19 | 21x10 | 300 | 6 | CD | 30288 | |
| 500 | 230 | - | 500/PAR64/MFL | - | 2700 | 32x19 | 21x10 | 2000 | 12 | CD | 39411 | |
| 500 | 230 | - | 500/PAR64/W FL | - | 2700 | - | - | 2000 | 12 | CD | 39414 | |
| New | 1000 | 230 | CP60 | EXC SUPER | 352000 | 3200 | 12x9 | 20x17 | 300 | 6 | CD | 93409 |
| | 1000 | 240 | CP60 | EXC SUPER | 352000 | 3200 | 12x9 | 20x17 | 300 | 6 | CD | 10925 |
| | 1000 | 230 | CP61 | EXD SUPER | 297000 | 3200 | 14x10 | 22x20 | 300 | 6 | CD | 10928 |
| | 1000 | 240 | CP61 | EXD SUPER | 297000 | 3200 | 14x10 | 22x20 | 300 | 6 | CD | 10929 |
| | 1000 | 230 | CP62 | EXE SUPER | 138000 | 3200 | 24x11 | 38x20 | 300 | 6 | CD | 10930 |
| | 1000 | 240 | CP62 | EXE SUPER | 138000 | 3200 | 24x11 | 38x20 | 300 | 6 | CD | 10931 |
| | 1000 | 230 | CP95 | - | 15000 | 3200 | 125x95 | 70x70 | 300 | 6 | CD | 30277 |
| | 1000 | 240 | CP95 | - | 15000 | 3200 | 125x95 | 70x70 | 300 | 6 | CD | 30278 |
| | 1000 | 230 | - | EXG/PAR64/WFL | 38000 | 3200 | 73x36 | 57x21 | 300 | 6 | CD | 35482 |
| | 1000 | 240 | - | EXG/PAR64/WFL | 38000 | 3200 | 73x36 | 57x21 | 300 | 6 | CD | 35483 |

PAR Lamps continued

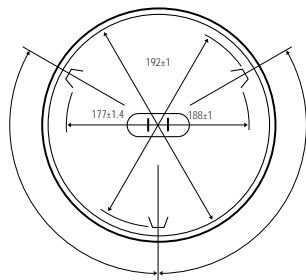
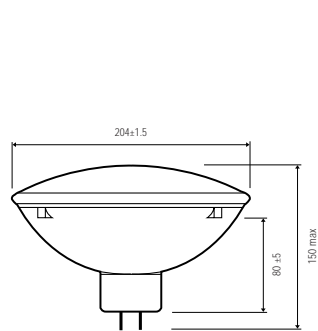

PAR 64 GX16d cap (EMEP)



| W | V | OC | Cd | K | 10° | 50° | Lumens | Beam | CD | Part No. |
|------|-----|-----------------|--------|------|-------|-------|--------|------|----|----------|
| 500 | 120 | 500PAR64/NSP | 110000 | 2800 | 19x14 | 12x7 | 2000 | 12 | CD | 39406 |
| 500 | 120 | 500PAR64/MFL | 37000 | 2800 | 35x19 | 23x11 | 2000 | 12 | CD | 39409 |
| 1000 | 120 | FFN | 400000 | 3200 | 24x10 | 12x6 | 800 | 6 | CD | 13233 |
| 1000 | 120 | FFP | 330000 | 3200 | 26x14 | 14x7 | 800 | 6 | CD | 13229 |
| 1000 | 120 | FFR | 125000 | 3200 | 44x11 | 28x12 | 800 | 6 | CD | 13228 |
| 1000 | 120 | FFS | 40000 | 3200 | 71x45 | 48x24 | 800 | 6 | CD | 13227 |
| 1000 | 120 | FGN | 70000 | 5200 | 43x20 | 27x11 | 200 | 6 | CD | 13225 |
| 1000 | 120 | Q1000PAR64/NSP | 200000 | 3000 | 31x14 | 15x8 | 4000 | 6 | CD | 43497 |
| 1000 | 120 | Q1000PAR64/MFL | 80000 | 3000 | 45x22 | 28x12 | 4000 | 6 | CD | 43498 |
| 1000 | 120 | Q1000PAR64/VNSP | 33000 | 3000 | 72x45 | 48x24 | 4000 | 6 | CD | 43499 |

Single Ended Halogen Lamps

| | |
|-------------------------------|---------|
| HPL | 20 |
| New HPL additions | |
| G9.5 base | 21 |
| GY9.5 base | 22 - 23 |
| GX9.5 base | 24 - 25 |
| GY16 base | 26 |
| G22 base | 27 |
| New G22 80V | |
| P28s base | 28 - 29 |
| G38 base | 30 - 31 |
| New GX38 high wattages | |
| GX38q base | 33 |
| E40 base | 34 |
| P40s base | 35 |

An extensive range of lamps designed to optimal performance in today's precision range of stage, studio and architectural luminaires.

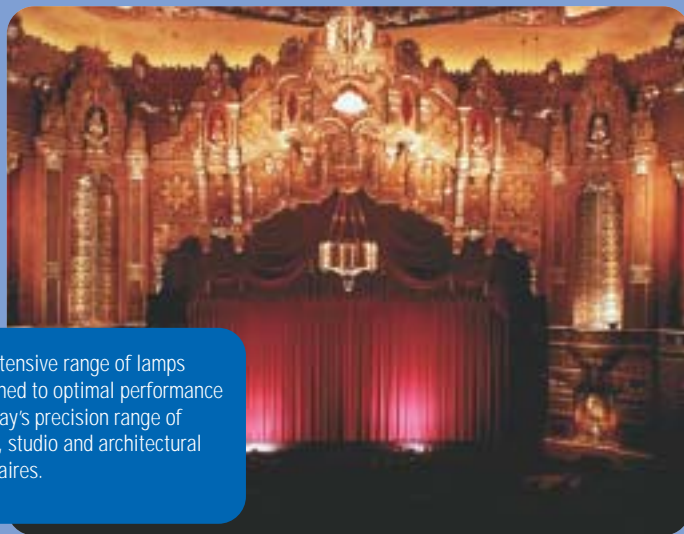

HPL



Lampes Halogenes Mono Culot

Une large gamme de lampes conçues pour optimiser les performances des luminaires destinés à l'éclairage architectural et studio.

OC 1200



Lampade Alogene ad Attacco Singolo

Una vasta gamma di lampade concepite per ottimizzare le prestazioni di sofisticati apparecchi di illuminazione per palcoscenico, studio e impiego architettonico.

12K GX38



Lámparas Halogenas Bipin

Un amplio rango de lámparas diseñadas para un óptimo rendimiento dentro de los aparatos de iluminación de precisión utilizados actualmente en la iluminación espectacular.

Einseitig-gesockelte Halogenlampen

Eine umfassende Auswahl an Lampen wurde entworfen, um eine optimale Leistung in der heutigen Präzisionsauswahl an Bühnen-, Studio- und architektonischer Beleuchtung zu bieten.

Single Ended Halogen

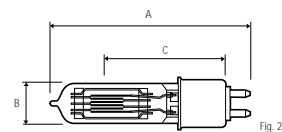
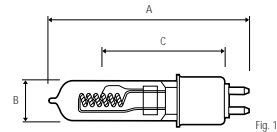
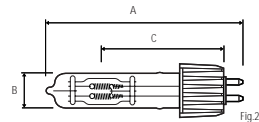
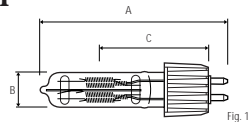

High Performance Lamps

| W | V | OC | LM | K | HxW | A | B | C | H | Life | FIG N° | | |
|-----|-----|-----------------|-------|------|-----|------------|-----|----|------|------|--------|--------|---|
| 575 | 230 | HPL 575 | 14900 | 3200 | SCH | 10 x 9.5 | 106 | 18 | 60.3 | 300 | 12 | 37128 | 1 |
| 575 | 240 | HPL 575 | 14900 | 3200 | SCH | 10 x 9.5 | 106 | 18 | 60.3 | 300 | 12 | 37131 | 1 |
| 575 | 120 | HPL 575-C | 16520 | 3250 | SCS | 9 x 6 | 106 | 18 | 60.3 | 300 | 12 | 92433 | 2 |
| 575 | 115 | HPL 575-C | 16520 | 3250 | SCS | 9 x 6 | 106 | 18 | 60.3 | 300 | 12 | 92431 | 2 |
| 575 | 230 | HPL 575-X LL | 11780 | 3050 | SCH | 12 x 9.5 | 106 | 18 | 60.3 | 1500 | 12 | 37817 | 1 |
| 575 | 240 | HPL 575-X LL | 11780 | 3050 | SCH | 12 x 9.5 | 106 | 18 | 60.3 | 1500 | 12 | 37818 | 1 |
| 575 | 120 | HPL 575-X LL-C | 12360 | 3050 | SCS | 11 x 6 | 106 | 18 | 60.3 | 2000 | 12 | 92435 | 2 |
| 575 | 115 | HPL 575-X LL-C | 12360 | 3050 | SCS | 11 x 6 | 106 | 18 | 60.3 | 2000 | 12 | 92434 | 2 |
| 750 | 230 | HPL 750 | 19750 | 3200 | SCH | 11.5 x 9.5 | 106 | 18 | 60.3 | 300 | 12 | 37824 | 1 |
| 750 | 240 | HPL 750 | 19750 | 3200 | SCH | 11.5 x 9.5 | 106 | 18 | 60.3 | 300 | 12 | 37826 | 1 |
| 750 | 115 | HPL 750-C | 22000 | 3250 | SCS | 10.5 x 6.3 | 106 | 18 | 60.3 | 300 | 12 | 92432 | 2 |
| 750 | 115 | HPL 750-XLL-C | 16400 | 3050 | SCS | 13 x 6.3 | 106 | 18 | 60.3 | 2000 | 12 | 92770* | 2 |
| 750 | 230 | HPL 750-XLL-C | 15600 | 3050 | SCH | 13 x 8 | 106 | 18 | 60.3 | 1500 | 12 | 92768* | 1 |
| 750 | 240 | HPL 750-C-XLL-C | 15600 | 3050 | SCH | 13 x 8 | 106 | 18 | 60.3 | 1500 | 12 | 92769* | 1 |

*Available mid 2003
The HPL 750w version has a pinned base to ensure correct application

G9.5 base

| W | V | OC | ANSI | LM | K | HxW | A | B | C | H | Life | FIG N° | |
|------|-----|-------|--------|-------|------|----------------|-----|----|------|------|------|---------|---|
| 500 | 120 | - | EHD | 10000 | 2900 | CC-8 18x5 | 105 | 20 | 60.5 | 2000 | 24 | W 39768 | 1 |
| 575 | 115 | HX600 | FLK | 16500 | 3200 | CC-8 12.7x6 | 105 | 18 | 60.5 | 300 | 24 | W 11450 | 1 |
| 575 | 115 | - | FLK/LL | 12800 | 3100 | CC-8 13.7x6 | 105 | 18 | 60.5 | 1500 | 50 | W 39730 | 1 |
| 600 | 230 | HX600 | GKV | 14000 | 3200 | C13-D 13.5x7.5 | 105 | 18 | 60.5 | 250 | 24 | - 39739 | 2 |
| 600 | 240 | HX600 | GKV | 14000 | 3200 | C13-D 13.5x7.5 | 105 | 18 | 60.5 | 250 | 24 | - 39750 | 2 |
| 600 | 230 | - | GKV/LL | 11000 | 3000 | C13-D 16x8 | 105 | 18 | 60.5 | 1500 | 24 | - 39751 | 2 |
| 600 | 240 | - | GKV/LL | 11000 | 3000 | C13-D 16x8 | 105 | 18 | 60.5 | 1500 | 24 | - 39752 | 2 |
| 650 | 230 | - | FKR | 15000 | 3100 | CC-8 24x5 | 105 | 20 | 60.5 | 300 | 24 | W 39734 | 1 |
| 650 | 240 | - | FKR | 15000 | 3100 | CC-8 24x5 | 105 | 20 | 60.5 | 300 | 24 | W 39735 | 1 |
| 750 | 120 | - | EHF | 20000 | 3200 | CC-8 19x7 | 105 | 20 | 60.5 | 300 | 24 | W 39771 | 1 |
| 750 | 120 | - | EHG | 15000 | 3000 | CC-8 19x7 | 105 | 20 | 60.5 | 2000 | 24 | W 39770 | 1 |
| 800 | 230 | HX800 | - | 20000 | 3200 | C13-D 15.8x8.4 | 105 | 18 | 60.5 | 250 | 24 | - 39753 | 2 |
| 800 | 240 | HX800 | - | 20000 | 3200 | C13-D 15.8x8.4 | 105 | 18 | 60.5 | 250 | 24 | - 39754 | 2 |
| 1000 | 120 | CP77 | FEL | 27500 | 3200 | CC-8 19x7 | 105 | 20 | 60.5 | 300 | 24 | W 39769 | 1 |
| 1000 | 230 | CP77 | FEP | 25000 | 3200 | CC-8 24x7 | 105 | 20 | 60.5 | 300 | 24 | W 39738 | 1 |
| 1000 | 240 | CP77 | FEP | 25000 | 3200 | CC-8 24x7 | 105 | 20 | 60.5 | 300 | 24 | W 39736 | 1 |

GKV/LL IS EQUIVALENT TO GLB

Single Ended Halogen Continued

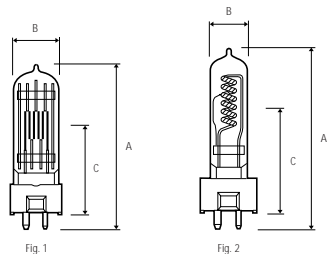

GY9.5 base - Grid-form Filament

| W | V | LIF | OC | LM | K | | HxW | A | B | C | | | | | FIG N° |
|-----|-----|------|-----|-------|------|----|-----------|----|----|----|-----|----|---|-------|--------|
| 300 | 120 | CP81 | FKW | 6900 | 3200 | S | 15x10 | 90 | 25 | 46 | 50 | 24 | - | 39781 | 1 |
| 300 | 230 | CP81 | FSL | 6900 | 3200 | S | 11x10 | 90 | 25 | 46 | 150 | 24 | - | 39780 | 1 |
| 300 | 240 | CP81 | FSK | 6900 | 3200 | S | 11x10 | 90 | 25 | 46 | 150 | 24 | - | 39779 | 1 |
| 500 | 120 | CP82 | FRG | 13000 | 3200 | MP | 12.5x11.5 | 90 | 25 | 46 | 150 | 24 | - | 39623 | 1 |
| 500 | 230 | CP82 | FRH | 12500 | 3200 | MP | 13x13 | 90 | 25 | 46 | 150 | 24 | - | 39624 | 1 |
| 500 | 240 | CP82 | FRJ | 12500 | 3200 | MP | 13x13 | 90 | 25 | 46 | 150 | 24 | - | 39628 | 1 |

GY9.5 base - Grid-form filament

| W | V | LIF | OC | LM | K | | HxW | A | B | C | | | | | FIG N° |
|-----|-----|------|-----|-------|------|----|-----------|----|----|------|-----|----|---|-------|--------|
| 500 | 230 | T18 | GCV | 11000 | 3050 | MP | 13.5x13 | 90 | 23 | 46 | 400 | 24 | - | 39717 | 1 |
| 500 | 240 | T18 | GCW | 11000 | 3050 | MP | 13.5x13 | 90 | 23 | 46 | 400 | 24 | - | 39629 | 1 |
| 500 | 230 | T25 | GCV | 11000 | 3000 | BP | 11X11 | 90 | 23 | 46.5 | 360 | 24 | - | 39455 | 1 |
| 500 | 240 | T25 | GCW | 11000 | 3000 | BP | 11X11 | 90 | 23 | 46.5 | 360 | 24 | - | 39262 | 1 |
| 650 | 230 | T27 | GCT | 14500 | 3050 | BP | 13X11 | 90 | 23 | 46.5 | 400 | 24 | - | 39456 | 1 |
| 650 | 240 | T27 | GCS | 14500 | 3050 | BP | 13X11 | 90 | 23 | 46.5 | 400 | 24 | - | 39457 | 1 |
| 650 | 120 | T26 | FRE | 15500 | 3100 | MP | 13.5x13.5 | 90 | 23 | 46 | 500 | 24 | - | 39630 | 1 |
| 650 | 230 | T26 | GCT | 15500 | 3100 | MP | 15.5x13.5 | 90 | 23 | 46 | 400 | 24 | - | 39635 | 1 |
| 650 | 240 | T26 | GCS | 15500 | 3100 | MP | 15.5x13.5 | 90 | 23 | 46 | 400 | 24 | - | 39636 | 1 |
| 650 | 120 | CP89 | FRK | 16900 | 3200 | MP | 12.5x11.5 | 90 | 25 | 46 | 200 | 24 | - | 39637 | 1 |
| 650 | 230 | CP89 | FRL | 16250 | 3200 | MP | 13x13 | 90 | 25 | 46 | 150 | 24 | - | 39640 | 1 |
| 650 | 240 | CP89 | FRM | 16250 | 3200 | MP | 13x13 | 90 | 25 | 46 | 150 | 24 | - | 39642 | 1 |

S = Staggered Filament Burning position VBD ±90

GY9.5 base - Coiled Coil Filament

| | | | | | | | | | | | | | | | |
|-----|-----|--|-----|-------|------|------|------|----|----|----|------|----|---|-------|---|
| 600 | 120 | | FMR | 12600 | 3050 | CC-8 | 16x6 | 85 | 16 | 51 | 2000 | 24 | W | 30475 | 2 |
|-----|-----|--|-----|-------|------|------|------|----|----|----|------|----|---|-------|---|

Single Ended Halogen Continued

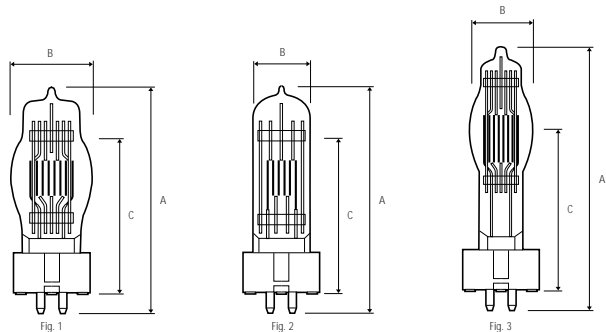

GX9.5 base



| | | | | | | | | | | | | | | | |
|------|---------|------|------------|-------|------|----|-----------|-----|----|----|-----|----|----|-------|---|
| 650 | 230 | T12 | - | 13500 | 3000 | MP | 15.5x14.5 | 110 | 25 | 55 | 750 | 12 | - | 39661 | 2 |
| 650 | 240 | T12 | - | 13500 | 3000 | MP | 15.5x14.5 | 110 | 25 | 55 | 750 | 12 | - | 39663 | 2 |
| 650 | 230 | CP23 | - | 16900 | 3200 | MP | 12x14.5 | 110 | 25 | 55 | 100 | 12 | - | 39654 | 2 |
| 650 | 240 | CP23 | - | 16900 | 3200 | MP | 12x14.5 | 110 | 25 | 55 | 100 | 12 | - | 39660 | 2 |
| 1000 | 230 | CP24 | - | 26000 | 3200 | MP | 18.5x17.5 | 110 | 35 | 55 | 200 | 12 | - | 39651 | 1 |
| 1000 | 240 | CP24 | - | 26000 | 3200 | MP | 18.5x17.5 | 110 | 35 | 55 | 200 | 12 | - | 39653 | 1 |
| 1000 | 115/120 | T11 | Q1000T8/CL | 23500 | 3050 | MP | 16x14 | 110 | 35 | 55 | 750 | 24 | - | 29331 | 1 |
| 1000 | 230 | T11 | - | 23000 | 3050 | MP | 17.5x17.5 | 110 | 35 | 55 | 750 | 12 | - | 39656 | 1 |
| 1000 | 240 | T11 | - | 23000 | 3050 | MP | 17.5x17.5 | 110 | 35 | 55 | 750 | 12 | - | 39659 | 1 |
| 1000 | 230 | T19 | FWR | 21000 | 3050 | BP | 15x12 | 110 | 35 | 55 | 750 | 12 | HJ | 39657 | 2 |
| 1000 | 240 | T19 | FWR | 21000 | 3050 | BP | 15x12 | 110 | 35 | 55 | 750 | 12 | HJ | 39658 | 2 |
| 1000 | 230 | CP70 | FVA | 25000 | 3200 | BP | 15x12 | 110 | 35 | 55 | 200 | 12 | HJ | 39241 | 2 |
| 1000 | 240 | CP70 | FVB | 25000 | 3200 | BP | 15x12 | 110 | 35 | 55 | 200 | 12 | HJ | 39242 | 2 |
| 1200 | 120 | T29 | - | 30500 | 3050 | BP | 15x13 | 125 | 35 | 67 | 400 | 12 | - | 39647 | 3 |
| 1200 | 230 | T29 | FWS | 29000 | 3050 | BP | 16x13 | 125 | 35 | 67 | 400 | 12 | - | 39723 | 3 |
| 1200 | 240 | T29 | FWT | 29000 | 3050 | BP | 16x13 | 125 | 35 | 67 | 400 | 12 | - | 39667 | 3 |
| 1200 | 230 | CP90 | - | 33000 | 3200 | BP | 16x12 | 125 | 35 | 67 | 200 | 12 | J | 39724 | 3 |
| 1200 | 240 | CP90 | - | 33000 | 3200 | BP | 16x12 | 125 | 35 | 67 | 200 | 12 | - | 39725 | 3 |

Burning position VBD ±90

Single Ended Halogen Continued

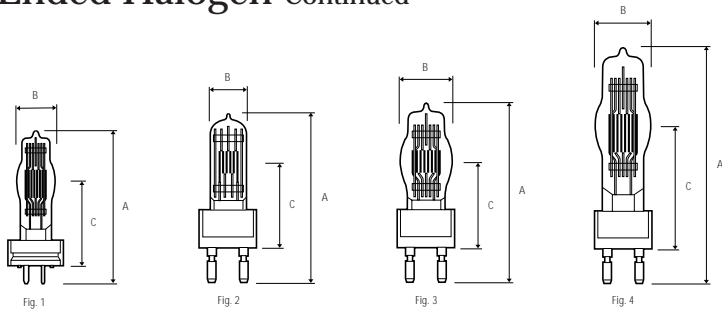

GY16 base

| W | V | LIF | OC | LM | K | BP | HxW | A | B | C | Light | Beam | File | Light | FIG N° |
|------|-----|------|-----|-------|------|----|---------|-----|----|----|-------|------|------|----------|--------|
| 2000 | 230 | CP43 | FTM | 54000 | 3200 | MP | 22x22.5 | 145 | 40 | 70 | 400 | 12 | - | 20309 | 1 |
| 2000 | 240 | CP43 | FTL | 54000 | 3200 | MP | 22x22.5 | 145 | 40 | 70 | 400 | 12 | - | 20310 | 1 |
| 2000 | 120 | CP79 | - | 56000 | 3200 | BP | 17.5x16 | 145 | 40 | 70 | 400 | 12 | - | 13053864 | 1 |
| 2000 | 230 | CP79 | - | 54000 | 3200 | BP | 18.5x17 | 145 | 40 | 70 | 350 | 12 | H | 30497 | 1 |
| 2000 | 240 | CP79 | - | 54000 | 3200 | BP | 18.5x17 | 145 | 40 | 70 | 350 | 12 | - | 30498 | 1 |

Burning position VBD ±90

New

G22 Low Voltage

| W | V | OC | LM | K | BP | HxW | A | B | C | Light | Beam | File | Light | FIG N° |
|------|----|--------|-------|------|----|-----------|-----|----|------|-------|------|------|-------|--------|
| 1200 | 80 | OC1200 | 37500 | 3300 | BP | 10.5x12.5 | 140 | 26 | 63.5 | 300 | 12 | - | 91580 | 2 |

G22 base

| W | V | LIF | ANSI | LM | K | BP | HxW | A | B | C | Light | Beam | File | Light | FIG N° |
|------|-----|------|------|-------|------|----|-----------|-----|----|------|-------|------|------|-------|--------|
| 500 | 120 | - | EGN | 13000 | 3200 | MP | 12x11.5 | 140 | 21 | 63.5 | 150 | 12 | - | 30373 | 2 |
| 650 | 230 | CP39 | FKH | 16900 | 3200 | MP | 12x14.5 | 140 | 25 | 63.5 | 100 | 12 | - | 20320 | 2 |
| 650 | 240 | CP39 | FKH | 16900 | 3200 | MP | 12x14.5 | 140 | 25 | 63.5 | 100 | 12 | - | 20321 | 2 |
| 1000 | 120 | - | EGT | 28500 | 3200 | MP | 14.5x14 | 140 | 22 | 63.5 | 250 | 12 | - | 39191 | 2 |
| 1000 | 230 | CP40 | FKJ | 26000 | 3200 | MP | 18.5x17.5 | 140 | 26 | 63.5 | 200 | 12 | - | 39655 | 2 |
| 1000 | 240 | CP40 | FKJ | 26000 | 3200 | MP | 18.5x17.5 | 140 | 26 | 63.5 | 200 | 12 | - | 20286 | 2 |
| 1200 | 240 | CP93 | - | 33000 | 3200 | BP | 16x12 | 140 | 35 | 63.5 | 200 | 12 | - | 30384 | 3 |
| 2000 | 120 | CP92 | - | 55000 | 3200 | BP | 18x17 | 175 | 40 | 90 | 400 | 12 | - | 30391 | 4 |
| 2000 | 230 | CP92 | - | 52000 | 3200 | BP | 18.5x17 | 175 | 40 | 90 | 400 | 12 | - | 30394 | 4 |
| 2000 | 240 | CP92 | - | 52000 | 3200 | BP | 18.5x17 | 175 | 40 | 90 | 400 | 12 | - | 30397 | 4 |
| 2500 | 230 | CP91 | - | 67500 | 3200 | BP | 24x18 | 175 | 40 | 90 | 400 | 12 | - | 30415 | 4 |
| 2500 | 240 | CP91 | - | 67500 | 3200 | BP | 24x18 | 175 | 40 | 90 | 400 | 12 | - | 30423 | 4 |

Burning position VBD ±90

Single Ended Halogen Continued

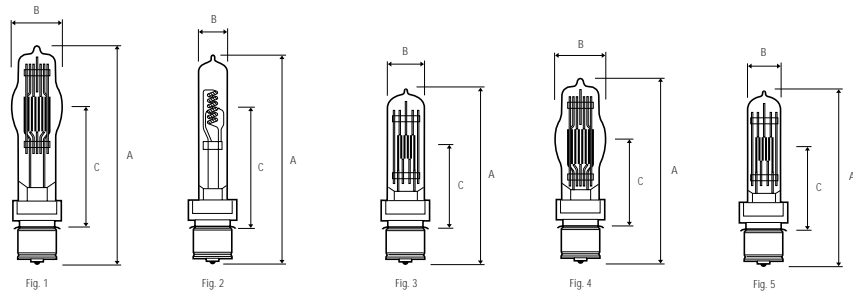

P28s base (medium prefocus)

| W | V | LIF | ANSI | LM | K | | HxW | A | B | C | | | | | FIG N° |
|-----|-----|-----|------|-------|------|------|-----------|-----|----|------|------|----|---|-------|--------|
| 500 | 120 | - | EGE | 10450 | 2950 | CC-8 | 18x5 | 152 | 13 | 88.9 | 2000 | 12 | - | 39135 | 2 |
| 500 | 120 | - | BTM | 13000 | 3200 | MP | 12x11.5 | 130 | 21 | 55.5 | 150 | 12 | - | 16465 | 5 |
| 500 | 230 | T17 | FKF | 9500 | 2950 | MP | 13.5x14.5 | 130 | 21 | 55.5 | 750 | 12 | - | 30535 | 5 |
| 500 | 240 | T17 | - | 9500 | 2950 | MP | 13.5x14.5 | 130 | 21 | 55.5 | 750 | 12 | - | 30536 | 5 |
| 500 | 230 | T28 | - | 11000 | 3000 | MP | 15x12 | 130 | 12 | 55.5 | 300 | 12 | - | 39731 | 5 |

Burning position VBU ±90

P28s base (medium prefocus)

| W | V | LIF | ANSI | LM | K | | HxW | A | B | C | | | | | FIG N° |
|------|-----|------|------|-------|------|------|-----------|-----|----|------|-----|----|---|-------|--------|
| 500 | 240 | T28 | - | 11000 | 3000 | MP | 15x12 | 130 | 21 | 55.5 | 300 | 12 | - | 39733 | 5 |
| 650 | 230 | T13 | FKB | 13500 | 3000 | MP | 15.5x14.5 | 130 | 25 | 55.5 | 750 | 12 | - | 30541 | 3 |
| 650 | 240 | T13 | - | 13500 | 3000 | MP | 15.5x14.5 | 130 | 25 | 55.5 | 750 | 12 | - | 30542 | 3 |
| 650 | 230 | CP51 | FKM | 16900 | 3200 | MP | 12x14.5 | 130 | 25 | 55.5 | 200 | 12 | - | 20323 | 3 |
| 650 | 240 | CP51 | - | 16900 | 3200 | MP | 12x14.5 | 130 | 25 | 55.5 | 200 | 12 | - | 20324 | 3 |
| 1000 | 120 | - | EGJ | 27500 | 3200 | CC-8 | 19x7 | 152 | 20 | 88.9 | 500 | 12 | W | 38853 | 2 |
| 1000 | 230 | - | EWE | 26500 | 3200 | CC-8 | 24x6 | 152 | 20 | 88.9 | 250 | 12 | W | 30533 | 2 |
| 1000 | 230 | T14 | FKD | 23000 | 3050 | MP | 17.5x17.5 | 130 | 35 | 55.5 | 750 | 12 | - | 20385 | 4 |
| 1000 | 240 | - | EWE | 26500 | 3200 | CC-8 | 24x6 | 152 | 20 | 88.9 | 250 | 12 | W | 30534 | 2 |
| 1000 | 240 | T14 | - | 23000 | 3050 | MP | 17.5x17.5 | 130 | 35 | 55.5 | 750 | 12 | - | 20388 | 4 |
| 1000 | 240 | T15 | FKE | 23000 | 3050 | MP | 17.5x17.5 | 160 | 35 | 88.9 | 750 | 12 | - | 30532 | 1 |
| 1000 | 240 | CP52 | FKN | 26000 | 3200 | MP | 18.5x17.5 | 130 | 35 | 55.5 | 200 | 12 | - | 30546 | 4 |

Burning position VBD ±90

Single Ended Halogen Continued

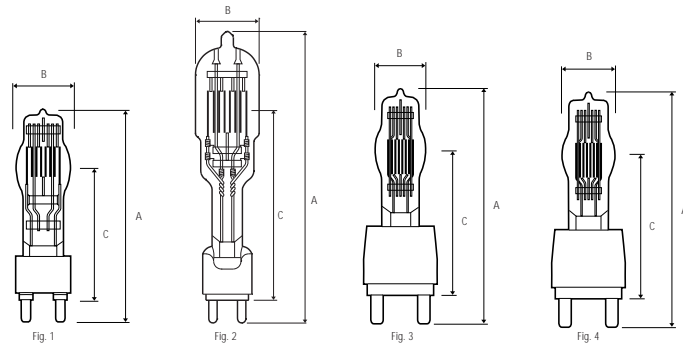

G38 base (mogul prefocus)



| | | | | | | | | | | | | | | | |
|-------|---------|-------|-----|--------|------|----|-----------|-----|----|-----|-----|----|---|-------|---|
| 1000 | 230 | HX270 | - | 25000 | 3200 | BP | 15x12 | 216 | 35 | 127 | 200 | 12 | - | 35234 | 3 |
| 1000 | 240 | HX270 | - | 25000 | 3200 | BP | 15x12 | 216 | 35 | 127 | 200 | 12 | - | 35233 | 3 |
| 2000 | 120 | HX270 | CYX | 59000 | 3200 | MP | 21.5x20.5 | 216 | 32 | 127 | 400 | 6 | - | 36636 | 3 |
| 2000 | 230 | CP41 | FKK | 54000 | 3200 | MP | 22x22.5 | 216 | 32 | 127 | 400 | 12 | - | 31844 | 3 |
| 2000 | 240 | CP41 | FKK | 54000 | 3200 | MP | 22x22.5 | 216 | 32 | 127 | 400 | 12 | - | 31849 | 3 |
| 2500 | 230 | CP94 | - | 67500 | 3200 | BP | 24x18 | 210 | 40 | 127 | 400 | 12 | - | 30499 | 3 |
| 2500 | 240 | CP94 | - | 67500 | 3200 | BP | 24x18 | 210 | 40 | 127 | 400 | 12 | - | 30500 | 3 |
| 3000 | 230 | HX48 | - | 82000 | 3200 | MP | 24x26 | 210 | 47 | 127 | 400 | 12 | K | 30503 | 4 |
| 3000 | 240 | HX48 | - | 82000 | 3200 | MP | 24x26 | 210 | 47 | 127 | 400 | 12 | K | 30504 | 4 |
| 5000 | 120 | CP29 | DPY | 143000 | 3200 | MP | 31x36 | 280 | 65 | 165 | 500 | 6 | - | 41736 | 1 |
| 5000 | 230 | CP29 | - | 135000 | 3200 | MP | 36x33 | 280 | 65 | 165 | 500 | 12 | - | 30505 | 1 |
| 5000 | 240 | CP29 | - | 135000 | 3200 | MP | 36x33 | 280 | 65 | 165 | 500 | 12 | - | 30506 | 1 |
| 10000 | 220/230 | CP83 | - | 280000 | 3200 | MP | 38x56 | 405 | 85 | 254 | 250 | 1 | - | 12036 | 2 |
| 10000 | 240 | CP83 | - | 280000 | 3200 | MP | 39x56 | 405 | 85 | 254 | 250 | 1 | - | 12037 | 2 |

Burning position VBD ±90 except HX48 VBD ±45

Single Ended Halogen Continued

New

GX38 base - Single-ended High Wattage Halogen Lamps

| W | V | LM | K | | HxW | A | B | C | | | | | FIG N° |
|---|---|----|---|--|-----|---|---|---|--|--|--|--|--------|
|---|---|----|---|--|-----|---|---|---|--|--|--|--|--------|

| | | | | | | | | | | | | | |
|-------|-----|--------|------|----|-------|-----|-----|-----|-----|---|---|-------|---|
| 12000 | 120 | 420000 | 3400 | MP | 31x56 | 410 | 254 | 85 | 150 | 1 | - | 48770 | 1 |
| 12000 | 230 | 420000 | 3400 | MP | 37x56 | 410 | 254 | 85 | 130 | 1 | - | 48771 | 1 |
| 12000 | 240 | 420000 | 3400 | MP | 36x56 | 410 | 254 | 85 | 130 | 1 | - | 48779 | 1 |
| 20000 | 230 | 580000 | 3200 | MP | 50x92 | 560 | 354 | 103 | 400 | 1 | - | 48773 | 2 |
| 20000 | 240 | 580000 | 3200 | MP | 52x92 | 560 | 354 | 103 | 400 | 1 | - | 48774 | 2 |
| 24000 | 230 | 800000 | 3400 | MP | 46x92 | 560 | 354 | 103 | 150 | 1 | - | 48776 | 2 |
| 24000 | 240 | 800000 | 3400 | MP | 52x92 | 560 | 354 | 103 | 150 | 1 | - | 48777 | 2 |

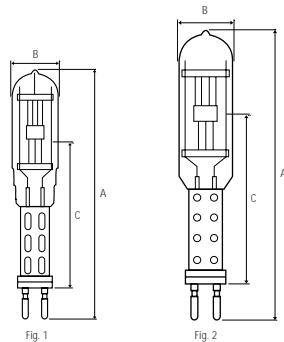

GX38q base - Twin filament

| W | V | LIF | LM | K | | HxW | A | B | C | | | | | FIG N° |
|---|---|-----|----|---|--|-----|---|---|---|--|--|--|--|--------|
|---|---|-----|----|---|--|-----|---|---|---|--|--|--|--|--------|

| | | | | | | | | | | | | | | |
|-----------|-----|-------|-------------------|------|----|---------------|-----|----|-----|-----|----|---|-------|---|
| 1250/650 | 230 | CP105 | 27000/13000 | 3050 | TF | 24x18.5 | 220 | 55 | 143 | 250 | 12 | L | 34056 | 1 |
| 1250/650 | 240 | CP105 | 27000/13000 | 3050 | TF | 24x18.5 | 220 | 55 | 143 | 250 | 12 | L | 34024 | 1 |
| 1250/1250 | 230 | CP30 | 27000/56000 | 3200 | TF | 24x18.5(x2) | 220 | 55 | 143 | 300 | 12 | L | 30513 | 1 |
| 1250/1250 | 240 | CP30 | 27000/56000 | 3200 | TP | 24x18.5(x2) | 220 | 55 | 143 | 300 | 12 | L | 30514 | 1 |
| 1250/2250 | 230 | CP58 | 27000/59000/91000 | 3200 | TF | 27.5x25/24x22 | 220 | 70 | 143 | 300 | 12 | L | 30515 | 1 |
| 1250/2500 | 240 | CP58 | 27000/59000/91000 | 3200 | TF | 27.5x25/24x22 | 220 | 70 | 143 | 300 | 12 | L | 30517 | 1 |
| 2500/2500 | 230 | CP32 | 59000/127000 | 3200 | TF | 27.5x25(x2) | 220 | 70 | 143 | 300 | 12 | L | 30518 | 1 |
| 2500/2500 | 240 | CP32 | 59000/127000 | 3200 | TF | 27.5x25(x2) | 220 | 70 | 143 | 300 | 12 | L | 30519 | 1 |

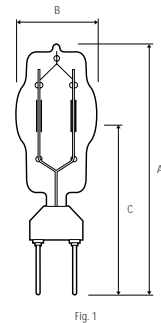

Burning position VBD ±45

Single Ended Halogen Continued

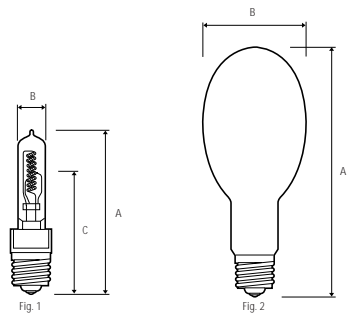

E40 base - Clear, Coil Filament



| | | | | | | | | | | | | | | | |
|------|---------|------|---|-------|------|------|------|-----|----|-----|-----|----|---|-------|---|
| 2000 | 220/230 | CP59 | - | 50000 | 3200 | CC-8 | 40x7 | 190 | 30 | 133 | 300 | 12 | W | 29424 | 1 |
| 2000 | 240 | CP59 | - | 50000 | 3200 | CC-8 | 40x7 | 190 | 30 | 133 | 300 | 12 | W | 29426 | 1 |

E40 base - Frosted, Coil Filament

| | | | | | | | | | | | | | | | |
|------|-----|---|---------|-------|------|------|---|-----|-----|---|------|----|---|-------|---|
| 1000 | 120 | - | DKZ/DSE | 28000 | 3200 | CC-8 | - | 330 | 165 | - | 750 | 10 | - | 34377 | 2 |
| 1500 | 120 | - | DKX/DSF | 41000 | 3200 | CC-8 | - | 330 | 165 | - | 1000 | 12 | - | 40357 | 2 |

DKX/DSF Burning position - any

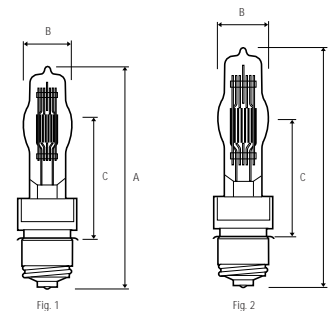

P40s base (mogul prefocus)



| | | | | | | | | | | | | | | | |
|------|-----|------|-----|-------|------|----|-----------|-----|----|----|-----|----|---|-------|---|
| 1000 | 240 | T16 | - | 23000 | 3050 | MP | 17.5x17.5 | 180 | 35 | 87 | 750 | 12 | - | 30521 | 1 |
| 1500 | 120 | T16 | DTA | 41000 | 3200 | MP | 19x17 | 200 | 40 | 87 | 300 | 6 | - | 30522 | 2 |
| 2000 | 230 | CP53 | - | 54000 | 3200 | MP | 22x22.5 | 200 | 40 | 87 | 400 | 12 | - | 20311 | 2 |
| 2000 | 240 | CP53 | - | 54000 | 3200 | MP | 22x22.5 | 200 | 40 | 87 | 400 | 12 | - | 20312 | 2 |

Burning position VBD ±90

Linear Halogen Lamps

Double-Ended Quartzline®

| | |
|-----------------|----|
| Length 79.4 mm | 38 |
| Length 95.3 mm | 39 |
| Length 119.1 mm | 40 |
| Length 142.9 mm | 41 |
| Length 189.1 mm | 42 |

This precision range of quartzline lamps are widely used in television broadcast studios around the world.



CNBC Europe's Studio.
CNBC, the 24-hour global business television news channel

P2/27



Lampes Halogenes Lineaires

Cette gamme spécifique de lampes quartz est très largement utilisée par les studios de télévision à travers le Monde.

Lampade Alogene Lineari

Questa gamma di lampade alogene è usata negli studi di produzione televisiva di tutto il mondo.

Lámparas Halógenas Lineales

Este rango de lámparas de cuarzo de alta precisión es ampliamente utilizado en los estudios de televisión de todo el mundo.

Stabförmige Halogenlampen

Die Genauigkeit der Quarzlampen sind weltweit in den Fernsehstudios verbreitet.

Linear Halogen

Double-Ended Quartzline® Lamps with R7s Caps

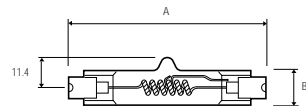

Fig. 1

Length 79.4mm

| W | V | LIF | OC | LM | K | + | A | B | H | □ | ☰ | 💡 | FIG N° |
|-----|-----|-------|-----|-------|------|------|------|------|-----|----|---|-------|--------|
| 650 | 120 | P2/6 | FAD | 16500 | 3200 | CC-8 | 79.4 | 13.5 | 100 | 24 | C | 30325 | 1 |
| 800 | 230 | P2/13 | DXX | 21400 | 3200 | CC-8 | 79.4 | 13.5 | 75 | 24 | C | 36952 | 1 |
| 800 | 240 | P2/13 | DXX | 21400 | 3200 | CC-8 | 79.4 | 13.5 | 75 | 24 | C | 36953 | 1 |

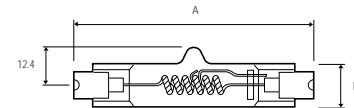
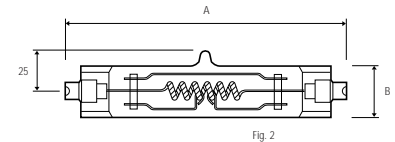
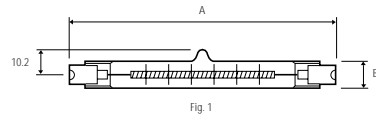

Fig. 2

Length 95.3mm

| W | V | OC | LM | K | + | A | B | H | □ | ☰ | 💡 | FIG N° |
|------|-----|-----|-------|------|------|------|----|-----|----|-------|-------|--------|
| 1000 | 120 | DXW | 28000 | 3200 | CC-8 | 95.3 | 16 | 150 | 24 | - | 30157 | 2 |
| 1000 | 120 | FBY | 26000 | 3200 | CC-8 | 95.3 | 16 | 150 | 24 | Frost | 30374 | 2 |

Linear Halogen Continued



Length 119.1mm - Burn Horizontal $\pm 4^\circ$

| W | V | LIF | OC | LM | K | | | | | | | | FIG N° |
|------|-----|-------|-------------|-------|------|-----|-------|----|------|----|---|-------|--------|
| 300 | 120 | - | EHM | 6200 | 2950 | C-8 | 119.1 | 11 | 2000 | 6 | - | 43703 | 1 |
| 500 | 120 | - | FCL | 11100 | 3000 | C-8 | 119.1 | 11 | 2000 | 12 | - | 23731 | 1 |
| 750 | 120 | - | EJG | 20600 | 3200 | C-8 | 119.1 | 11 | 400 | 12 | - | 23756 | 1 |
| 800 | 240 | P2/11 | EME/Clear | 22000 | 3200 | C-8 | 119.1 | 11 | 150 | 12 | - | 23760 | 1 |
| 800 | 240 | P2/11 | EMF/Frosted | 21400 | 3200 | C-8 | 119.1 | 11 | 150 | 12 | - | 23761 | 1 |
| 1000 | 120 | P2/28 | FCM | 28000 | 3200 | C-8 | 119.1 | 11 | 400 | 12 | - | 23797 | 1 |

Length 142.9mm - Burn Horizontal $\pm 4^\circ$ - RX7s Caps

| W | V | LIF | OC | LM | K | | | | | | | | FIG N° |
|------|-----|-------|-----|-------|------|------|-------|----|-----|----|---|-------|--------|
| 2000 | 230 | P2/27 | FEX | 50000 | 3200 | CC-8 | 142.9 | 30 | 300 | 12 | - | 35338 | 2 |
| 2000 | 240 | P2/27 | FEX | 50000 | 3200 | CC-8 | 142.9 | 30 | 300 | 12 | - | 35339 | 2 |
| 2000 | 120 | P2/27 | FEY | 57000 | 3200 | CC-8 | 142.9 | 30 | 400 | 12 | - | 39790 | 2 |

Linear Halogen Continued

Notes

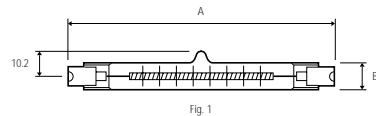

Length 189.1mm - Burn Horizontal $\pm 4^\circ$

| W | V | LIF | OC | LM | K | | A | B | | | | | FIG N° |
|------|-----|-------|-----|-------|------|-----|-------|----|-----|----|---|-------|--------|
| 625 | 230 | P2/10 | - | 16900 | 3200 | C-8 | 189.1 | 12 | 300 | 12 | - | 19697 | 1 |
| 625 | 240 | P2/10 | - | 16900 | 3200 | C-8 | 189.1 | 12 | 300 | 12 | - | 19698 | 1 |
| 1000 | 230 | P2/7 | EKM | 28000 | 3200 | C-8 | 189.1 | 12 | 300 | 12 | - | 20249 | 1 |
| 1000 | 240 | P2/7 | EKM | 28000 | 3200 | C-8 | 189.1 | 12 | 300 | 12 | - | 20253 | 1 |
| 1250 | 230 | P2/12 | - | 35000 | 3200 | C-8 | 189.1 | 12 | 300 | 12 | - | 19695 | 1 |
| 1250 | 240 | P2/12 | - | 35000 | 3200 | C-8 | 189.1 | 12 | 300 | 12 | - | 19696 | 1 |

Specialist Projector Lamps

| | |
|--------------------------|---------|
| Single-ended Quartzline® | 46 - 47 |
| A1 class projector | 48 |
| G17q | 49 |
| Low volt single ended | 50 |
| Mains volt single ended | 51 |
| Linear projector | 52 |
| MR16 projector | 53 -57 |
| New ELC 500 | |
| MR11 projector | 58 |
| MR13 projector | 59 |
| MR14 projector | 60 |
| High intensity arc | 61 |



A full range of specialist projection lamps designed to deliver excellent optical performance and reliability.

Overhead Projector, ACCO UK

Projector



Lampes Photo-Projection

Une gamme complète de lampes projection spécialement conçues afin de délivrer une excellente performance optique et d'une grande fiabilité.

Single Ended Capsules



Lampade da Proiezione

Una gamma completa di lampade da proiezione di grande affidabilità progettate per fornire eccellenti prestazioni ottiche

Specialist Projector



Projektionslampen

Eine komplette Auswahl an speziellen Projektionslampen, entworfen um eine ausgezeichneten optischen Performance und Verlässlichkeit zu bieten.

Specialist Projector

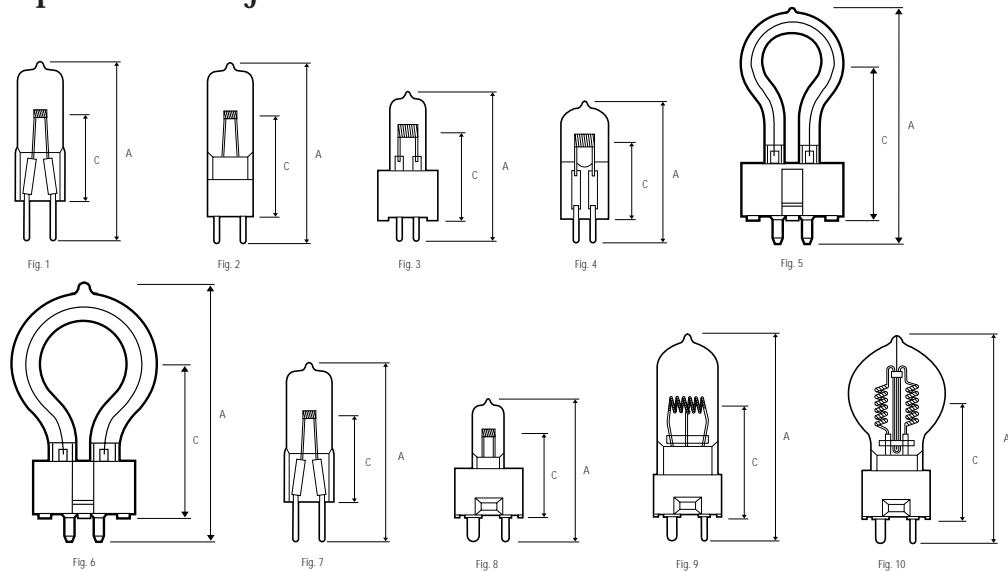

Single-ended Quartzline® - Projector Lamps



| | | | | | | | | | | | | | | | | |
|------|------|---------|--------|-------|------|----------|-----------|------|------|----|------|---------|-----|-----|-------|----|
| 30 | 6.6 | EXL | - | 375 | - | C-8 | 3.3x1.3 | 2900 | 44.5 | 25 | 1000 | GZ9.5 | 24 | M | 11478 | - |
| 30 | 10.8 | DZA | - | 800 | BDTH | C-6 | 3.8x1.3 | 3100 | 51 | 27 | 400 | G5.3 | 24 | M | 37346 | 4 |
| 50 | 12 | BRL | A1/220 | 1400 | BDTH | C-6 | 3.3x1.6 | 3400 | 44 | 30 | 50 | G6.35 | 100 | M | 18234 | 1 |
| 100 | 12 | FCR | A1/215 | 3500 | BDTH | C-6 | 5.1x3.8 | 3300 | 44 | 30 | 50 | GY6.35 | 100 | M | 14876 | 1 |
| 100 | 12 | FDT | A1/261 | 2900 | BDTH | C-6 Oval | 5.8x3.8 | 3300 | 54 | 27 | 50 | GZ9.5 | 24 | M | 35321 | 8 |
| 120 | 6.6 | EVV | - | 3150 | - | C-6 Oval | 6.4x3 | 3200 | 64 | 39 | 500 | GZ9.5 | 24 | M | 10099 | - |
| 150 | 6.6 | EWR | - | 4100 | - | C-6 Oval | 6.4x4.1 | 3200 | 64 | 39 | 500 | GZ9.5 | 24 | M | 11427 | - |
| 150 | 15 | BRJ/EVB | A1/234 | 5000 | BDTH | C-6 Oval | 4.8x3.0 | 3400 | 44 | 30 | 50 | G6.35 | 100 | M | 18235 | 1 |
| 150 | 24 | DZE/FDS | A1/262 | 5000 | BDTH | C-6 Oval | 6.4x3.8 | 3250 | 68 | 33 | 100 | GZ9.5 | 24 | M | 37695 | 8 |
| 150 | 24 | FCS | A1/216 | 4500 | BDTH | C-6 Oval | 6.4x3.8 | 3300 | 51 | 30 | 50 | G6.35 | 100 | M | 13598 | 1 |
| 175 | 24 | EML | - | 5000 | BDTH | C-6 | 5.3x4.8 | 3200 | 54 | 27 | 125 | G5.3 | 24 | M | 42612 | 3 |
| 250 | 24 | EHJ | A1/223 | 9000 | BDTH | C-6 Oval | 7.6x3.8 | 3400 | 57 | 33 | 50 | G6.35 | 100 | M | 14874 | 1 |
| 275 | 24 | FNT | - | 10000 | BDTH | C-6 Oval | 3.5x7.1 | 3400 | 57 | 33 | 50 | G6.35 | 100 | M | 18241 | 1 |
| 300 | 24 | FLW | - | 10200 | BDTH | C-6 Oval | 8.6x5.8 | 3500 | 55 | 33 | 50 | GY6.35* | 20 | M | 19886 | 2 |
| 400 | 36 | EVD | A1/239 | 16000 | BDTH | C-6 Oval | 9.4x4.7 | 3200 | 60 | 36 | 50 | GY6.35 | 25 | M | 41164 | 1 |
| 400 | 36 | - | A1/270 | 14500 | BDTH | CC | 9x4.6 | - | 57 | 36 | 150 | GY6.35 | 100 | M | 30888 | 7 |
| 500 | 230 | - | HX501 | 11500 | BDTH | - | - | 3050 | 60 | 46 | 300 | GX9.5 | 24 | M | 35484 | 5 |
| 600 | 120 | DYS | A1/264 | 17000 | BDTH | CC-6 | 12.7x6.4 | 3200 | 64 | 37 | 75 | GZ9.5 | 24 | CM | 32955 | 9 |
| 600 | 120 | FFJ | - | 17000 | - | CC-8 | - | 3250 | - | - | 85 | R7S | 24 | - | 29592 | - |
| 650 | 230 | DYR | A1/233 | 16500 | Any | 2CC-8 | 11.4x11.4 | 3200 | 64 | 37 | 50 | GZ9.5 | 24 | CMN | 33248 | 10 |
| 650 | 240 | DYR | A1/233 | 16500 | Any | 2CC-8 | 11.4x11.4 | 3200 | 64 | 37 | 50 | GZ9.5 | 24 | CM | 33250 | 10 |
| 800 | 120 | - | HX185 | 19000 | BDTH | - | - | 3050 | 100 | 53 | 300 | GX9.5 | 24 | M | 32714 | 6 |
| 800 | 230 | - | HX185 | 19000 | BDTH | - | - | 3050 | 100 | 53 | 300 | GX9.5 | 24 | M | 30949 | 6 |
| 800 | 240 | - | HX185 | 19000 | BDTH | - | - | 3050 | 100 | 53 | 300 | GX9.5 | 24 | M | 35232 | 6 |
| 1000 | 120 | BRH | - | 30000 | - | CC-8 | - | 3350 | - | - | 60 | R7S | 24 | - | 29604 | - |

* Ceramic

Specialist Projector continued

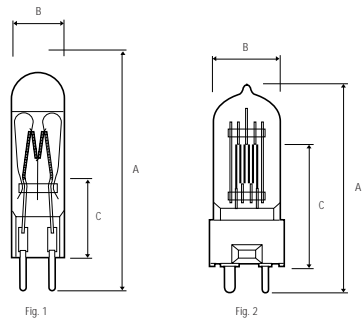

A1 Class Projector Bulbs



| | | | | | | | | | | | | | | |
|-----|---------|--------|-------|------|----|----|------|------|----|-------|----|-----|-------|---|
| 150 | 220/230 | A1/248 | 3000 | BDTH | MP | 62 | 16.3 | 40 | 50 | G6.35 | 50 | MT | 30584 | 1 |
| 150 | 240 | A1/248 | 3000 | BDTH | MP | 62 | 16.3 | 40 | 50 | G6.35 | 50 | MT | 30585 | 1 |
| 300 | 220/230 | A1/249 | 7200 | BDTH | MP | 62 | 16.3 | 40 | 50 | G6.35 | 50 | MNT | 30587 | 1 |
| 300 | 240 | A1/249 | 7200 | BDTH | MP | 62 | 16.3 | 40 | 50 | G6.35 | 50 | MNT | 30588 | 1 |
| 500 | 220/230 | A1/244 | 13000 | BDTH | MP | 75 | 28.5 | 36.5 | 75 | GY9.5 | 24 | MN | 39643 | 2 |
| 500 | 240 | A1/244 | 13000 | BDTH | MP | 75 | 28.5 | 36.5 | 75 | GY9.5 | 24 | MN | 39644 | 2 |
| 650 | 240 | A1/247 | 17750 | BDTH | MP | 75 | 28.5 | 36.5 | 75 | GY9.5 | 24 | MP | 39650 | 2 |
| 800 | 220/230 | A1/245 | 21500 | BDTH | MP | 87 | 28.5 | 44.5 | 75 | GY9.5 | 24 | MP | 39648 | 2 |
| 800 | 240 | A1/245 | 21500 | BDTH | MP | 87 | 28.5 | 44.5 | 75 | GY9.5 | 24 | MP | 39649 | 2 |

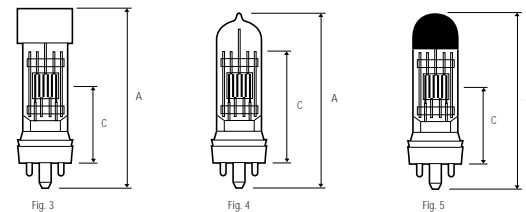

G17q cap



| | | | | | | | | | | | | | | |
|-----|-----|-----|--------|---|------|----|------|----|----|----|----|-------|-------|---|
| 500 | 240 | - | A1/241 | - | BDTH | BP | 3200 | 83 | 40 | 50 | 24 | MNSTQ | 39727 | 5 |
| 500 | 120 | CBA | - | - | BDTH | BP | 3200 | 92 | 44 | 50 | 24 | MNT | 36117 | 3 |
| 500 | 220 | EPS | A1/268 | - | BDTH | MP | 3250 | 94 | 40 | 50 | 24 | MNS | 39728 | 4 |
| 500 | 240 | EPS | A1/268 | - | BDTH | MP | 3250 | 94 | 40 | 50 | 24 | MNS | 39729 | 4 |

Specialist Projector continued

Single-ended Tungsten Halogen Lamps

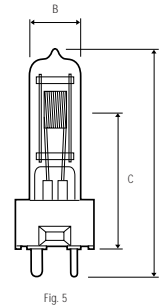
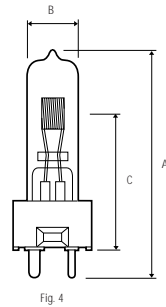
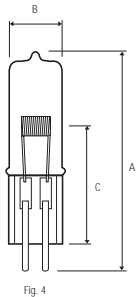
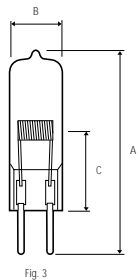
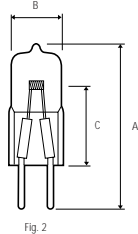
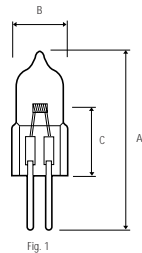

Low Voltage single-ended capsule

| W | V | LIF | A | B | C | LM | K | GY | Base | Life (hrs) | Temp (°C) | FIG N° | |
|-----|----|---------|----|------|------|------|------|--------|----------|------------|-----------|--------|---|
| 10 | 6 | M29/ESA | 30 | 10 | 19.5 | 200 | 3200 | G4 | Trans | 100 | 20 | 34720 | 1 |
| 20 | 6 | M30/ESB | 30 | 10 | 19.5 | 450 | 3200 | G4 | Trans | 100 | 20 | 34718 | 1 |
| 50 | 12 | M32 | 44 | 12 | 30 | 930 | 3000 | GY6.35 | Trans | 4000 | 20 | 34702 | 2 |
| 100 | 12 | M28/EVA | 44 | 12 | 30 | 2400 | 3000 | GY6.35 | C-6 Oval | 2000 | 20 | 34676 | 3 |
| 250 | 24 | M33 | 55 | 13.5 | 33 | 8600 | 3000 | G6.35 | C-6 Oval | 300 | 100 | 34768 | 3 |
| 250 | 24 | M36 | 58 | 15 | 30 | 5750 | 3000 | G6.35 | C-6 Oval | 2000 | 100 | 29231 | 4 |

Mains Voltage single-ended capsule

| W | V | LIF | A | B | C | LM | K | GY | Base | Life (hrs) | Temp (°C) | FIG N° | |
|-----|---------|-----|----|------|------|------|------|-------|------|------------|-----------|--------|---|
| 300 | 120 | M38 | 80 | 28.5 | 45.5 | 5500 | 2900 | GY9.5 | CC | 2000 | 24 | 39786 | 4 |
| 300 | 220/230 | M38 | 80 | 28.5 | 45.5 | 5000 | 2900 | GY9.5 | CC | 2000 | 24 | 39785 | 4 |
| 300 | 240/250 | M38 | 80 | 28.5 | 45.5 | 5000 | 2900 | GY9.5 | CC | 2000 | 24 | 39784 | 4 |
| 500 | 220/230 | M40 | 85 | 30 | 45.5 | 8500 | 2900 | GY9.5 | SC | 2000 | 24 | 39621 | 5 |
| 500 | 240/250 | M40 | 85 | 30 | 45.5 | 8500 | 2900 | GY9.5 | SC | 2000 | 24 | 39622 | 5 |

Specialist Projector continued

Double-ended lamps with R7s caps

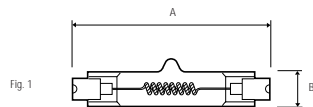

Linear Projector Lamps



| | | | | | | | | | | | | | |
|-----|-----|-----|--------|--------------------|------|------|------|------|------|----|---|-------|---|
| 200 | 20 | DDN | - | Microfilm | - | CC-8 | 60.1 | 13.5 | 3150 | 24 | M | 34570 | 1 |
| 375 | 30 | DWZ | A1/226 | Overhead projector | 1000 | CC-8 | 80.9 | 10 | 3000 | 24 | M | 29578 | 1 |
| 420 | 120 | FAL | A1/227 | Overhead projector | 75 | CC-8 | 66.5 | 13.5 | 3200 | 24 | M | 29581 | 1 |

Multi-Mirror® Quartzline® Projection lamps

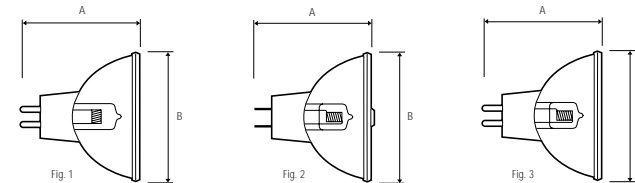

MR-16 Faceted Dichroic Reflector



| | | | | | | | | | | | | | | | |
|----|------|-----|--------|------------------|------|-----|------|-------|-------|------|--------|----|----|-------|---|
| 30 | 10.8 | EKZ | - | 16mm projection | 200 | 40 | C-6 | 44.45 | 50.67 | 3100 | GX5.3 | 20 | MV | 36902 | 1 |
| 50 | 13.8 | DJT | - | Microfilm | 1000 | 155 | CC-6 | 44.45 | 50.67 | 3150 | GX5.3 | 20 | MV | 44854 | 1 |
| 50 | 8 | EFM | A1/229 | 8mm projection | 50 | 32 | C-6 | 44.45 | 50.67 | 3300 | GZ6.35 | 20 | MV | 41251 | 2 |
| 75 | 12 | EFN | A1/230 | 8mm projection | 50 | 32 | CC-6 | 44.45 | 50.67 | 3350 | GZ6.35 | 20 | MV | 41252 | 2 |
| 80 | 19 | DDM | - | Slide projection | 50 | 155 | CC-6 | 44.45 | 50.67 | 3350 | GX5.3 | 20 | MV | 43206 | 1 |
| 80 | 21 | DDS | - | Microfilm | 1000 | 165 | CC-6 | 44.45 | 50.67 | 3125 | GX5.3 | 20 | MV | 43988 | 1 |

Specialist Projector continued

MR-16 Faceted Dichroic Reflector continued



| | | | | | | | | | | | | | | | | |
|------------|------|---------|--------|----------------------|-------|-----|------|-------|-------|-------|--------|-------|----|--------------|--------------|---|
| 85 | 13.8 | DED | - | Microfilm | 1000 | 165 | CC-6 | 44.45 | 50.67 | 3150 | GX5.3 | 20 | MV | 43950 | 1 | |
| 100 | 12 | EFP | A1/231 | 8mm projection | 50 | 32 | CC-6 | 44.45 | 50.67 | 3350 | GZ6.35 | 20 | MV | 41253 | 2 | |
| 150 | 15 | EFR | A1/232 | 8mm projection | 50 | 32 | CC-6 | 44.45 | 50.67 | 3350 | GZ6.35 | 20 | MV | 41254 | 2 | |
| 150 | 20 | DDL | - | Microfilm | 500 | 200 | CC-6 | 44.45 | 50.67 | 3150 | GX5.3 | 20 | MV | 43537 | 1 | |
| 150 | 21 | ELD/EJN | - | Microfilm | 40 | 165 | CC-6 | 44.45 | 50.67 | 3350 | GX5.3 | 20 | MV | 38306 | 1 | |
| 150 | 21 | EJM | - | 8mm projection | 40 | 40 | CC-6 | 44.45 | 50.67 | 3350 | GX5.3 | 10 | MV | 29151 | 1 | |
| 150 | 21 | EKE | - | 8mm projection | 200 | 45 | CC-6 | 44.45 | 50.67 | 3250 | GX5.3 | 20 | MV | 35200 | 1 | |
| 200 | 24 | EKX | - | Microfilm | 25 | 145 | CC-6 | 44.45 | 50.67 | 3400 | GX5.3 | 20 | MV | 36899 | 1 | |
| 200 | 24 | EJL | A1/252 | 16mm, Colour printer | 50 | 32 | CC-6 | 44.45 | 50.67 | 3400 | GX5.3 | 20 | MV | 29150 | 1 | |
| 250 | 24 | ELC | A1/259 | 16mm, Colour printer | 50 | 30 | CC-6 | 44.45 | 50.67 | 3400 | GX5.3 | 20 | MV | 37462 | 1 | |
| New | 250 | 24 | ELC500 | - | Disco | 500 | 30 | CC-6 | 44.45 | 50.67 | 3250 | GY5.3 | 20 | MV | 15377 | 1 |
| 250 | 120 | ENH | - | Slide projection | 175 | 155 | CC-8 | 44.45 | 50.67 | 3250 | GY5.3 | 20 | MV | 38686 | 3 | |
| 300 | 120 | ELH | - | Slide projection | 35 | 155 | CC-8 | 44.45 | 50.67 | 3350 | GY5.3 | 10 | MV | 38476 | 1 | |
| 300 | 120 | ENG | - | Slide projection | 15 | 155 | CC-8 | 44.45 | 50.67 | 3450 | GY5.3 | 10 | MV | 38685 | 3 | |

MR-16 Dichroic Reflector



| | | | | | | | | | | | | | | | |
|-----|----|-----|---|----------------|----|----|------|-------|-------|------|-------|----|----|--------------|---|
| 80 | 19 | EJY | - | Fibre optics | 25 | 40 | CC-6 | 44.45 | 50.67 | 3400 | GX5.3 | 20 | MV | 32886 | 1 |
| 80 | 30 | ELB | - | 8mm projection | 18 | 32 | CC-6 | 44.45 | 50.67 | 3400 | GX5.3 | 20 | MV | 37412 | 1 |
| 150 | 21 | EJA | - | Fibre optics | 40 | 28 | CC-6 | 44.45 | 50.67 | 3350 | GX5.3 | 20 | MV | 32882 | 1 |
| 150 | 21 | EJV | - | 8mm, printer | 40 | 45 | CC-6 | 44.45 | 50.67 | 3350 | GX5.3 | 20 | MV | 32831 | 1 |

MR-16 Dichroic Reflector



| | | | | | | | | | | | | | | | |
|-----|----|-----|--------|----------------|----|----|-------|------|----|----|------|-------|----|--------------|---|
| 150 | 21 | DNF | A1/266 | 8mm projection | 25 | 70 | Horiz | CC-6 | 45 | 50 | 3400 | GX7.9 | 24 | 39742 | 1 |
|-----|----|-----|--------|----------------|----|----|-------|------|----|----|------|-------|----|--------------|---|

Specialist Projector continued

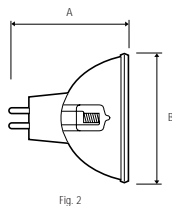
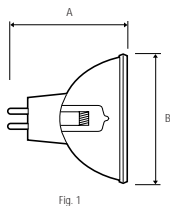

MR-16 Faceted Dichroic Reflector



| | | | | | | | | | | | | | | |
|-----|------|---------|----------------------|------|-----|------|-------|-------|------|-------|----|----|-------|---|
| 25 | 13.8 | FHX | Microfilm | 250 | 110 | CC-6 | 44.45 | 50.67 | 3200 | GX5.3 | 20 | MV | 47914 | 1 |
| 42 | 10.8 | EPT | Fibre optics | 8000 | 40 | C-6 | 44.45 | 50.67 | 2900 | GX5.3 | 20 | MV | 41729 | 1 |
| 50 | 12 | ENL | Fibre optics* | 4000 | 40 | C-6 | 44.45 | 50.67 | 3050 | GX5.3 | 20 | MV | 25475 | 1 |
| 50 | 13.8 | EPZ | Microfilm | 1000 | 110 | CC-6 | 44.45 | 50.67 | 3150 | GX5.3 | 20 | MV | 43948 | 1 |
| 50 | 13.8 | FML | Microfilm | 1000 | 215 | CC-6 | 44.45 | 50.67 | 3150 | GX5.3 | 20 | MV | 14887 | 1 |
| 80 | 19 | ENW/ENC | 8mm projection | 200 | 45 | CC-6 | 44.45 | 50.67 | 3200 | GX5.3 | 10 | MV | 40248 | 1 |
| 90 | 14.5 | EPV | Microfilm | 500 | 155 | CC-6 | 44.45 | 50.67 | 3150 | GX5.3 | 20 | MV | 41882 | 1 |
| 90 | 14.5 | EPX | Microfilm | 500 | 165 | CC-6 | 44.45 | 50.67 | 3150 | GX5.3 | 20 | MV | 42614 | 1 |
| 150 | 120 | ESD | Enlarger, projection | 12 | 45 | CC-8 | 44.45 | 50.67 | 3350 | GY5.3 | 20 | MV | 43756 | 2 |
| 150 | 120 | EZK | Camera light | 200 | - | CC-8 | 44.45 | 50.67 | 3200 | GY5.3 | 20 | MV | 15477 | 2 |
| 200 | 24 | EWf | Overhead projection | 50 | 300 | CC-8 | 44.45 | 50.67 | 3300 | GX5.3 | 20 | MV | 11132 | 2 |
| 200 | 82 | EYA | Enlarger | 50 | - | CC-8 | 44.45 | 50.67 | 3300 | GY5.3 | 20 | MV | 13152 | 2 |
| 250 | 82 | EVW | Overhead projection | 50 | 300 | CC-8 | 44.45 | 50.67 | 3300 | GY5.3 | 20 | MV | 11110 | 2 |
| 250 | 120 | EXX | Camera light | 25 | - | CC-8 | 44.45 | 50.67 | 3300 | GY5.3 | 20 | MV | 11750 | 2 |
| 340 | 36 | ERV | Overhead projection | 75 | 300 | CC-8 | 44.45 | 50.67 | 3300 | GX5.3 | 20 | MV | 41874 | 2 |
| 360 | 100 | EPW | Overhead projection | 75 | 300 | CC-6 | 44.45 | 50.67 | 3250 | GY5.3 | 20 | MV | 41702 | 2 |
| 360 | 82 | ENX | Overhead projection | 75 | 300 | CC-8 | 44.45 | 50.67 | 3300 | GY5.3 | 20 | MV | 41705 | 2 |
| 410 | 82 | FXL | Overhead projection | 38 | 300 | CC-8 | 44.45 | 50.67 | 3300 | GY5.3 | 20 | MV | 21613 | 2 |

* Display lighting

Specialist Projector continued

Multi-Mirror® Quartzline® Projection lamps

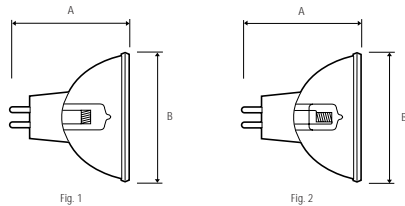

MR-11 Faceted Dichroic Reflector



| | | | | | | | | | | | | | | |
|----|------|-----|-----------|------|-----------|------|----|------|------|-----|----|----|-------|---|
| 28 | 12 | FLS | Microfilm | 1000 | 216 | CC-6 | 40 | 35.3 | 3000 | GZ4 | 10 | MV | 30894 | 1 |
| 28 | 13.8 | FLT | Microfilm | 500 | 76 or 175 | CC-6 | 40 | 35.3 | 3050 | GZ4 | 10 | MV | 31964 | 1 |

MR-13 Faceted Dichroic Reflector



| | | | | | | | | | | | | | | |
|-----|----|---------|------------------|-----|-----|------|------|------|------|-------|----|----|-------|---|
| 250 | 82 | EXY | Slide projection | 200 | 150 | CC-8 | 44.4 | 42.4 | 3200 | GX5.3 | 10 | MV | 12097 | 2 |
| 225 | 68 | EZF/EZJ | Colour printer | 500 | - | CC-8 | 44.4 | 42.4 | | GX5.3 | 10 | MV | 15832 | 2 |
| 300 | 82 | EXR | Slide projection | 35 | 150 | CC-8 | 44.4 | 42.4 | 3350 | GX5.3 | 10 | MV | 12092 | 2 |
| 300 | 82 | EXW | Slide projection | 15 | 150 | CC-8 | 44.4 | 42.4 | 3450 | GX5.3 | 10 | MV | 12095 | 2 |
| 300 | 82 | FHS | Slide projection | 70 | 150 | CC-8 | 44.4 | 42.4 | 3300 | GX5.3 | 10 | MV | 47614 | 2 |

Specialist Projector continued

G7.9 Vented Cap Reflector Quartzline®

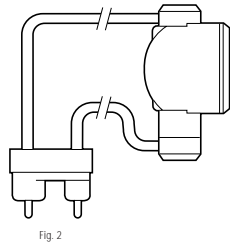
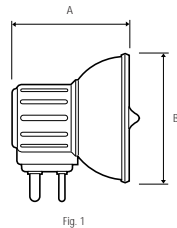

MR-14 Dichroic Reflector



| | | | | | | | | | | | | | | | |
|-----|----|---------|--------|-----------------|-----|-----|------|------|------|------|------|-------|----|-------|---|
| 50 | 16 | ELS/ELR | - | Microfilm | 650 | 120 | BDTH | CC-6 | 36 | 44.4 | 3100 | GX7.9 | 24 | 41885 | 1 |
| 250 | 24 | EMM/EKS | A1/258 | 16mm projection | 50 | 67 | BDTH | CC-6 | 42.2 | 44.4 | 3400 | GX7.9 | 24 | 40017 | 1 |

High Intensity Arc

| W | V | ANSI | D | | | | | | | | | | | | |
|-----|----|------|--------------------|--|------------------------------|----|----|------|---|-------|---|--|--|--|--|
| 300 | 35 | EZG | Gemini 300 (EZG) | Quartz Arc Tube in 50mm dichroic reflector | Special 2-pin polarized plug | 37 | 75 | 6000 | 4 | 11134 | 2 | | | | |
| 350 | 45 | EZT | Marc-350/16T (EZT) | Quartz Arc Tube in 76mm dichroic reflector | Special 2-pin polarized plug | 52 | 50 | 5000 | 4 | 39936 | 2 | | | | |

Gemini and Marc lamps should be operated with the plane of the reflector vertical. These lamps should not be operated for periods of less than three minutes since short operating cycles reduce life and degrade performance.

Discharge Lamps

| | |
|--|-------|
| New CSR & CSD | 64-65 |
| CMH (Ceramic Metal Halide) | 66-68 |
| CSS compact | 69 |
| CSI/CID | 70-75 |
| Circuit diagrams | 76-78 |
| New Cinema Lamps-High Lumen Biax™ | 79 |
| New Cinema Lamps-Fluorescent | 79-81 |
| Linear ultra violet | 81 |

New CSR & CSD lamps have been introduced to increase the range of discharge products for use in Stage & Studio applications.



MGM Grand, Las Vegas, Discharge lighting being used in one of the top Entertainment resorts.

CSD 250/2



CSR 575/2



Lampes à Decharge
 Les nouvelles lampes CSR & CSD ont été lancées afin d'élargir l'offre destinée aux applications scéniques et studios

Lampade a Scarica
 Le nuove lampade CSR & CSD sono state introdotte per implementare la gamma delle lampade scarica utilizzabili in teatri e studi

Lámparas de Descarga
 Nuevas lamparas CSR y CSD han sido lanzadas al mercado para incrementar el rango de productos de descarga para uso en aplicaciones de Estudio y Teatro

Hochdruckentladungslampen
 Die neuen CSR & CSD Lampen wurden eingeführt, als Sortimentserweiterung im Entladungslampenbereich für die Bühnen und Studioleuchtung.

Discharge lamps

New

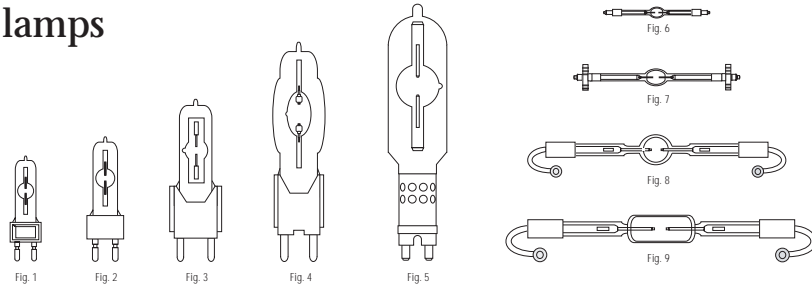

Single Ended Hot Restrike

| W | CCT | V | | F | BP | H | LM | D | | H | FIG N° |
|-------|------|-----|--------|-------|-----------|------|---------|----------------|-----|-------|--------|
| 125 | 5600 | 80 | GZY9.5 | CLEAR | UNIVERSAL | 200 | 9400 | CSR125/SE/HR | 10 | 48461 | 1 |
| 200 | 5600 | 80 | GZY9.5 | CLEAR | UNIVERSAL | 200 | 15000 | CSR200/SE/HR | 10 | 48462 | 1 |
| 400 | 5900 | 70 | GX9.5 | CLEAR | UNIVERSAL | 1000 | 32000 | CSR400/SE/HR | TBA | TBA* | - |
| 575 | 6000 | 95 | G22 | CLEAR | UNIVERSAL | 750 | 48000 | CSR575/SE/HR | 10 | 48463 | 2 |
| 1200 | 6000 | 100 | G38 | CLEAR | UNIVERSAL | 750 | 110000 | CSR1200/SE/HR | 6 | 48464 | 3 |
| 2500 | 6000 | 115 | G38 | CLEAR | UNIVERSAL | 500 | 220000 | CSR2500/SE/HR | 6 | 48465 | 4 |
| 4000 | 6000 | 200 | G38 | CLEAR | UNIVERSAL | 500 | 380000 | CSR4000/SE/HR | 6 | 48466 | 4 |
| 6000 | 6000 | 123 | G38 | CLEAR | UNIVERSAL | 300 | 540000 | CSR6000/SE/HR | 6 | 48467 | 5 |
| 12000 | 6000 | 160 | G38 | CLEAR | UNIVERSAL | 250 | 1100000 | CSR12000/SE/HR | 4 | 48468 | 5 |

* Available late 2003

New

Single Ended Cold Start

| W | CCT | V | | F | BP | H | LM | D | | H | FIG N° |
|------|------|-----|-----------|-------|-----------|------|--------|----------------|----|-------|--------|
| 250 | 8500 | 90 | GY9.5 | CLEAR | UNIVERSAL | 2000 | 18000 | CSD250/2/SE | 10 | 10744 | - |
| 575 | 7200 | 95 | GX9.5 | CLEAR | UNIVERSAL | 1000 | 49000 | CSR575/2/T/SE | 10 | 49492 | - |
| 575 | 7200 | 95 | GX9.5 | CLEAR | UNIVERSAL | 1000 | 49000 | CSR575/2/SE | 10 | 15378 | - |
| 700 | 7200 | 72 | G22 | CLEAR | UNIVERSAL | 1000 | 55000 | CSR700/2/SE | 10 | 49491 | - |
| 1200 | 7200 | 100 | G22/30x53 | CLEAR | UNIVERSAL | 1000 | 110000 | CSR1200/2/T/SE | 6 | 15379 | - |
| 1200 | 7200 | 100 | G22/30x53 | CLEAR | UNIVERSAL | 1000 | 110000 | CSR1200/2/SE | 6 | 49490 | - |

Double Ended Hot Restrike

| | | | | | | | | | | | |
|-------|------|---|------------------------------|-------|----------------|-----|---------|--------------|----|-------|---|
| 200 | 6000 | - | X515 | CLEAR | HORIZONTAL±15° | 300 | 16000 | CSR200/DE | 10 | 48450 | 6 |
| 575 | 6000 | - | SFc 10-4 Sleeve/Thd.Pin M4 | CLEAR | HORIZONTAL±15° | 750 | 49000 | CSR575/DE | 10 | 48451 | 7 |
| 1200 | 6000 | - | SFc 10-4 Sleeve/Thd.Pin M6 | CLEAR | HORIZONTAL±15° | 500 | 110000 | CSR1200S/DE | 10 | 48452 | 7 |
| 1200 | 6000 | - | SFc 10-5-6 Sleeve/Thd.Pin M6 | CLEAR | HORIZONTAL±15° | 750 | 110000 | CSR1200/DE | 10 | 48453 | 7 |
| 2500 | 6000 | - | Sta 21-12 | CLEAR | HORIZONTAL±15° | 500 | 240000 | CSR2500/DE | 6 | 48454 | 8 |
| 4000 | 6000 | - | Sta 21-12 | CLEAR | HORIZONTAL±15° | 500 | 410000 | CSR4000/DE | 6 | 48455 | 8 |
| 6000 | 6000 | - | 25x51 cylinder LEAD 165mm | CLEAR | HORIZONTAL±15° | 300 | 570000 | CSR6000/DE | 10 | 48456 | 8 |
| 12000 | 6000 | - | 30x70 cylinder LEAD 165mm | CLEAR | HORIZONTAL±15° | 300 | 1100000 | CSR12000/DE | 10 | 48457 | 9 |
| 18000 | 6000 | - | 30x70 cylinder LEAD 165mm | CLEAR | HORIZONTAL±15° | 300 | 1650000 | CSR18000/DE | 6 | 48459 | 9 |
| 18000 | 6000 | - | 30x70 cylinder LEAD 165mm | CLEAR | HORIZONTAL±15° | 300 | 1650000 | CSR18000S/DE | 6 | 48460 | 9 |

Short Arc

| | | | | | | | | | | | |
|------|------|-----|-------|-------|---------------------|------|-------|-----------|-----|--------|---|
| 700 | 5600 | 70 | GY9.5 | CLEAR | UNIVERSAL/LEAD DOWN | 750 | 55000 | CSR700SA | TBA | 15380* | - |
| 1200 | 5600 | 100 | GY22 | CLEAR | UNIVERSAL/LEAD DOWN | 1000 | 96000 | CSR1200SA | TBA | TBA* | - |

* Available late 2003

Discharge lamps continued

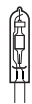

Fig 1

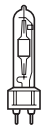

Fig 2



Fig 3

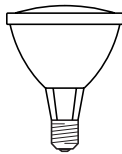

Fig 4

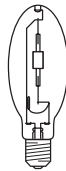

Fig 5



Fig 6

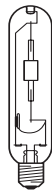

Fig 7

Ceramic Metal Halide (CMH)



Single Ended 'Minis'

| | | | | | | | | | | | | |
|----|------|-----|------|------|-------|-----------|-------|-------|------|-------------------------|-------|---|
| 20 | 3000 | 80+ | T4.5 | G8.5 | CLEAR | UNIVERSAL | 9000 | 7500 | 1700 | CMH20/TC/UVC/U/830/G8.5 | 92079 | 1 |
| 35 | 3000 | 80+ | T4.5 | G8.5 | CLEAR | UNIVERSAL | 10000 | 10000 | 3400 | CMH35/TC/UVC/U/830/G8.5 | 38697 | 1 |
| 70 | 3000 | 80+ | T4.5 | G8.5 | CLEAR | UNIVERSAL | 9000 | 9000 | 6200 | CMH70/TC/UVC/U/830/G8.5 | 38700 | 1 |

Single Ended

| | | | | | | | | | | | | |
|-----|------|-----|----|-----|-------|-----------|-------|-------|-------|------------------------|-------|---|
| 35 | 3000 | 80+ | T6 | G12 | CLEAR | UNIVERSAL | 10000 | 10000 | 3400 | CMH35/T/UVC/U/830/G12 | 38696 | 2 |
| 70 | 3000 | 80+ | T6 | G12 | CLEAR | UNIVERSAL | 15000 | 15000 | 6000 | CMH70/T/UVC/U/830/G12 | 36844 | 2 |
| 70 | 4200 | 90+ | T6 | G12 | CLEAR | UNIVERSAL | 15000 | 15000 | 6000 | CMH70/T/UVC/U/942/G12 | 38701 | 2 |
| 150 | 3000 | 80+ | T6 | G12 | CLEAR | UNIVERSAL | 12000 | 12000 | 14000 | CMH150/T/UVC/U/830/G12 | 36863 | 2 |
| 150 | 4200 | 90+ | T6 | G12 | CLEAR | UNIVERSAL | 12000 | 12000 | 13000 | CMH150/T/UVC/U/942/G12 | 38694 | 2 |

Ceramic Metal Halide (CMH)



Double Ended

| | | | | | | | | | | | | |
|-----|------|-----|----|---------|-------|------------------|-------|---|-------|---------------------------|-------|---|
| 70 | 3000 | 80+ | T6 | Rx7s | CLEAR | HORIZONTAL ± 45° | 15000 | - | 7000 | CMH70/TD/UVC/830/Rx7s | 36910 | 3 |
| 70 | 4200 | 90+ | T6 | Rx7s | CLEAR | HORIZONTAL ± 45° | 15000 | - | 6200 | CMH70/TD/UVC/942/Rx7s | 38698 | 3 |
| 150 | 3000 | 80+ | T7 | Rx7s-24 | CLEAR | HORIZONTAL ± 45° | 15000 | - | 14500 | CMH150/TD/UVC/830/Rx7s-24 | 36912 | 3 |
| 150 | 4200 | 90+ | T7 | Rx7s-24 | CLEAR | HORIZONTAL ± 45° | 15000 | - | 12500 | CMH150/TD/UVC/942/Rx7s-24 | 38692 | 3 |

PAR 20

| | | | | | | | | | | | | |
|----|------|-----|-------|-----|-------|-----------|-------|-------|------|------------------------|-------|---|
| 35 | 3000 | 80+ | PAR20 | E27 | CLEAR | UNIVERSAL | 10000 | 10000 | 2100 | CMH35/PAR20/830/E27/SP | 41883 | 4 |
| 35 | 3000 | 80+ | PAR20 | E27 | CLEAR | UNIVERSAL | 10000 | 10000 | 2100 | CMH35/PAR20/830/E27/FL | 41884 | 4 |

PAR 30

| | | | | | | | | | | | | |
|----|------|-----|-------|-----|-------|-----------|-------|-------|------|------------------------|-------|---|
| 35 | 3000 | 80+ | PAR30 | E27 | CLEAR | UNIVERSAL | 10000 | 10000 | 2400 | CMH35/PAR30/830/E27/SP | 41886 | 4 |
| 35 | 3000 | 80+ | PAR30 | E27 | CLEAR | UNIVERSAL | 10000 | 10000 | 2400 | CMH35/PAR30/830/E27/FL | 41887 | 4 |
| 70 | 3000 | 80+ | PAR30 | E27 | CLEAR | UNIVERSAL | 10000 | 10000 | 4700 | CMH70/PAR30/830/E27/SP | 41621 | 4 |
| 70 | 3000 | 80+ | PAR30 | E27 | CLEAR | UNIVERSAL | 10000 | 10000 | 4700 | CMH70/PAR30/830/E27/FL | 41620 | 4 |

Architainment PAR64

| | | | | | | | | | | | | |
|-----|-----|-----|-------|-------|-----|-----|-----|-----|-----|--------------------------|------|---|
| 150 | TBA | TBA | PAR64 | GX16d | TBA | TBA | TBA | TBA | TBA | CMH PAR64 150W GX16d NSP | TBA* | - |
| 150 | TBA | TBA | PAR64 | GX16d | TBA | TBA | TBA | TBA | TBA | CMH PAR64 150W GX16d MF | TBA* | - |
| 150 | TBA | TBA | PAR64 | GX16d | TBA | TBA | TBA | TBA | TBA | CMH PAR64 150W GX16d WFL | TBA* | - |

* Available late 2003

Stage & Studio

| | | | | | | | | | | | | |
|-----|------|----|--|-----|-------|-----------|------|------|-------|---------------|------|---|
| 150 | 4200 | 96 | | G12 | CLEAR | UNIVERSAL | 6000 | 6000 | 12900 | CMH150 SA G12 | TBA* | - |
|-----|------|----|--|-----|-------|-----------|------|------|-------|---------------|------|---|

* Available late 2003

Discharge lamps continued

Ceramic Metal Halide (CMH) continued



Elliptical Clear

| | | | | | | | | | | | | |
|-----|------|-----|------|-----|-------|-----------|-------|-------|------|----------------------|-------|---|
| 70 | 3000 | 80+ | ED17 | E27 | CLEAR | UNIVERSAL | 15000 | 15000 | 6300 | CMH70/E/U/830/E27/C | 46189 | 5 |
| 100 | 3000 | 80+ | ED17 | E27 | CLEAR | UNIVERSAL | 15000 | 10000 | 9200 | CMH100/E/U/830/E27/C | 46191 | 5 |

Elliptical Diffuse

| | | | | | | | | | | | | |
|-----|------|-----|------|-----|---------|------------|-------|-------|-------|------------------------|--------|---|
| 70 | 3000 | 80+ | ED17 | E27 | DIFFUSE | UNIVERSAL | 15000 | 15000 | 6000 | CMH70/E/U/830/E27/D | 46187 | 6 |
| 100 | 3000 | 80+ | ED17 | E27 | DIFFUSE | UNIVERSAL | 15000 | 10000 | 8700 | CMH100/E/U/830/E27/D | 46194 | 6 |
| 250 | 3000 | 80+ | ED28 | E40 | DIFFUSE | UNIVERSAL | 15000 | 15000 | 23500 | CMH250/E/VBU/830/E40/D | 10591* | 6 |
| 400 | 3000 | 80+ | ED18 | E40 | DIFFUSE | VBU | - | 15000 | 40000 | CMH400/E/VBU/830/E40/D | 92952 | 6 |
| 400 | 3000 | 80+ | ED37 | E40 | DIFFUSE | HORIZONTAL | 15000 | - | 40000 | CMH400/E/HOR/830/E40/D | 13087* | 6 |

Tubular Clear

| | | | | | | | | | | | | |
|-----|------|-----|------|-----|-------|------------|-------|-------|-------|----------------------|---------|---|
| 70 | 3000 | 80+ | T12 | E27 | CLEAR | UNIVERSAL | 15000 | 15000 | 6600 | CMH70/T/830/E27 | 38752 | 7 |
| 100 | 3000 | 80+ | T15 | E40 | CLEAR | UNIVERSAL | 12000 | 12000 | 9200 | CMH100/T/830/E40 | 92478** | 7 |
| 150 | 3000 | 80+ | T15 | E40 | CLEAR | UNIVERSAL | 12000 | 12000 | 14000 | CMH150/T/830/E40 | 38749 | 7 |
| 250 | 3000 | 80+ | T15 | E40 | CLEAR | UNIVERSAL | 15000 | 15000 | 25000 | CMH250/T/U/830/E40 | 10589* | 7 |
| 400 | 3000 | 80+ | ED18 | E40 | CLEAR | VBU | - | 15000 | 42000 | CMH400/T/VBU/830/E40 | 92951 | 7 |
| 400 | 3000 | 80+ | ED37 | E40 | CLEAR | HORIZONTAL | 15000 | - | 42000 | CMH400/T/HOR/830/E40 | 13067* | 7 |

*available in the second quarter 2003

**available in the fourth quarter 2003

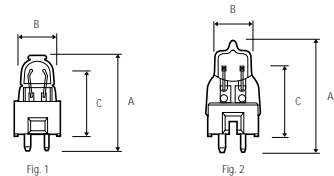

CSS



| | | | | | | | | | | |
|-----|----|------------------|-------|------|----|----|----|------|----|-------|
| 140 | 85 | CSS150/850/GY9.5 | 10000 | 5000 | 48 | 22 | 30 | 1000 | 10 | GY9.5 |
| 575 | 95 | CSS575/855/GY9.5 | 40250 | 5500 | 94 | 22 | 52 | 500 | 10 | GY9.5 |



| | | | | | | | | | | |
|--------|--------|----|-----|---|------|-----|---|---------|-------|---|
| x0.346 | y0.358 | 80 | BDH | 6 | 1.87 | 120 | 3 | 3.5 - 5 | 34813 | 1 |
| x0.322 | y0.341 | 85 | BDH | 9 | 7 | 60 | 5 | 9 | 34822 | 2 |

Discharge lamps continued

CSI/CID Lamps (Compact Source Iodide/Compact Iodide Daylight)

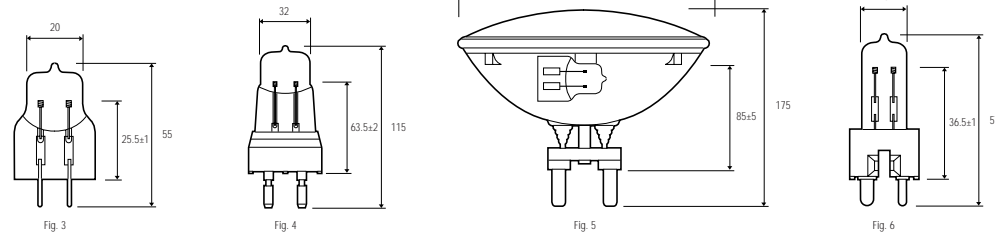

Special bipin base (2 pin 9mm)

| W | V | OC | LM 100 | % | H | K | XY | CRI | BP | mm | |
|-----|-----|----------------|--------|--------------------------------|----------|-----------------------|------------------|-----|--------|-----|--------------------------|
| 400 | 100 | 99-0201 CSI | 32000 | 85% at 500 hrs | 500 | 4000±400 | x0.385 y0.395 | 80 | VBD±90 | 9±1 | ±0.5 spacing 0.76 dia |
| amp | RC | SO | RO | I | TV | + | FIG N° | | | | |
| 5 | 30 | 9 Peak | 5 | G53444 or Bag Turgi SE15/7U | G53371.T | 7xGC2331 40µF 250V | 30555 | 3 | | | |

G22 base (medium bipost)

| W | V | OC | LM 100 | % | H | K | XY | CRI | BP | mm | |
|------|----|----------------|--------|--------------------------------|----------|------------------------|------------------|-----|--------|------|---|
| 1000 | 77 | 99-0221 CSI | 90000 | 85% at 500 hrs | 500 | 4000±400 | x0.385 y0.395 | 80 | VBD±90 | 14±1 | - |
| amp | RC | SO | RO | I | TV | + | FIG N° | | | | |
| 15 | 60 | 9 Peak | 5 | G53444 or Bag Turgi SE15/7U | G53307.T | 7xGC2346 175µF 250V | 30558 | 4 | | | |

G38 base (mogul bipost)

| W | V | OC | Cd | 1/2 | 1/10 | H | K | XY | CRI | BP | |
|------|----|----------------|---------------------------|--------------------------------|----------|------------------------|--------------|------------------|-----|--------|--------|
| 1000 | 77 | 99-1222 CSI | 1350000 | 6 | 18 | 3500 | 3800±500 | x0.393 y0.395 | 80 | HOR±90 | 15±1.5 |
| 1000 | 77 | 99-1422 CSI | 1350000 | 6 | 18 | 3500 | 3800±500 | x0.393 y0.395 | 80 | HOR±90 | 15±1.5 |
| amp | RC | SO | RO | I | TV | + | FIG N° | | | | |
| 15 | 60 | 12 Peak | 10 | G53444 or Bag Turgi SE15/7U | G53307.T | 7xGC2346 175µF 250V | 29333 | 5 | | | |
| 15 | 60 | 25* | Instant (hot restrike) | G53352.T or IREM AD1540 | G53307.T | 7xGC2346 175µF 250V | 29336 | 5 | | | |

*Measured between sphere gap of 7.5mm in air
Circuit diagrams for CSI/CID lamps can be found on pages 76-78 this includes other essential components

Discharge lamps continued

Special Bipin base

| W | V | OC | LM 100 | % | h | K | XY | CRI | BP | mm |
|-----|----|----------------|---------------------------|----------------|----------|---------------------|------------------|-----|--------|---------|
| 200 | 70 | 99-0211 CID | 14000 | 90% at 150 hrs | 150 | 5500±400 | x0.332 y0.341 | 85 | VBD±90 | 5.5±1.5 |
| amp | RC | S | R | I | | | | | | FIG N° |
| 3.3 | 60 | 12 Peak | Instant (hot restrike) | IREM AD312R | G53398.T | GC2382 35µF 250V | 30560 | 6 | | |

Circuit diagrams for CSI/CID lamps can be found on pages 76-78 this includes other essential components

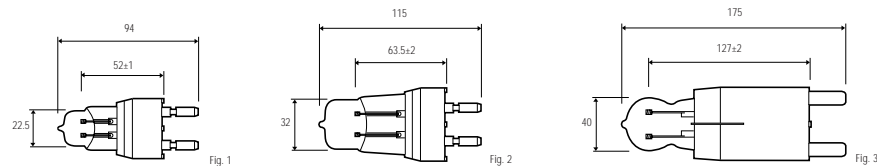

G22 base (medium bipost)

| W | V | OC | LM 100 | % | h | K | XY | CRI | BP | mm |
|------|----|----------------|--------|--------------------------------|--------------|------------------------|------------------|-----|--------|--------|
| 575 | 95 | 99-0415 CID | 40250 | 90% at 500 hrs | 500 | 5500±400 | x0.322 y0.341 | 85 | VBD±90 | 9±1 |
| 1000 | 77 | 99-0222 CID | 70000 | 90% at 500 hrs | 500 | 5500±400 | x0.332 y0.341 | 85 | VBD±90 | 15±1.5 |
| amp | RC | S | R | I | | | | | | FIG N° |
| 7 | 60 | 9 Peak | 5 | G53444 or Bag Turgi SE15/7U | IREM ZA57 | 4xGC2331 80µF 250V | 30563 | 1 | | |
| 15 | 60 | 9 Peak | 5 | G53444 or Bag Turgi SE15/7U | G53307.T | 7xGC2346 175µF 250V | 30561 | 2 | | |

Discharge lamps continued

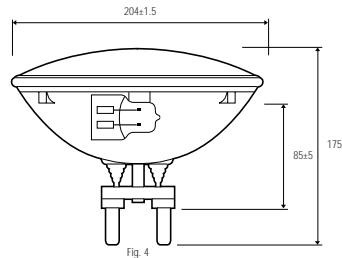

G38 base (mogul bipost)

| W | V | OC | Cd | % ⚡ | ⚡ | K | XY | CRI | BP | mm |
|------|-----|----------------|--------|----------------|-----|----------|------------------|-----|--------|------|
| 2500 | 100 | 99-0431 CID | 200000 | 90% at 350 hrs | 350 | 5500±400 | x0.332 y0.341 | 85 | VBD±90 | 18±1 |

| amp | RC | SO | RO | I | ⚡ | ⚡ | ⚡ | FIG N° |
|-----|----|-----|---------------------------|-----------------|-------------|-------------------------|--------------|--------|
| 28 | 60 | 50* | Instant (hot restrike) | IREM AD30/50 | 2x G53307.T | 11xGC2346 275µF 250V | 30567 | 3 |

* Measured between sphere gap of 17mm in air

G38 base (mogul bipost)

| W | V | OC | Cd | ⚡ ₂ | ⚡ ₁₀ | ⚡ | K | XY | CRI | BP | mm |
|------|-----|----------------|--------|----------------|-----------------|------|----------|------------------|-----|--------|--------|
| 1000 | 77 | 99-1225 CID | 850000 | 8 | 20 | 1500 | 5500±400 | x0.333 y0.341 | 85 | HOR±90 | 15±1.5 |
| 1000 | 77 | 99-1425 CID | 850000 | 8 | 20 | 1000 | 5500±400 | x0.333 y0.341 | 85 | HOR±90 | 15±1.5 |
| 1200 | 100 | 99-1435 CID | 820000 | 9 | 18 | 1000 | 5500±400 | x0.332 y0.341 | 85 | HOR±90 | 18±1 |

| amp | RC | SO | RO | I | ⚡ | ⚡ | ⚡ | FIG N° |
|-----|----|---------|---------------------------|--------------------------------|----------|------------------------|--------------|--------|
| 15 | 60 | 12 Peak | 10 | G53444 or Bag Turgi SE15/7U | G53307.T | 7xGC2346 175µF 250V | 30360 | 4 |
| 15 | 60 | 25* | Instant (hot restrike) | G53352.T or IREM AD1540 | G53307.T | 7xGC2346 175µF 250V | 30371 | 4 |
| 14 | 80 | 50** | Instant (hot restrike) | IREM AD1550 | G53307.T | 6xGC2346 150µF 250V | 30372 | 4 |

* Measured between sphere gap of 7.5mm in air

** Measured between sphere gap of 17mm in air

Circuit diagrams for CSI/CID lamps can be found on pages 76-78 this includes other essential components

Discharge lamps continued

200 Watt CID Hot-Restart Lamp Circuit Diagram

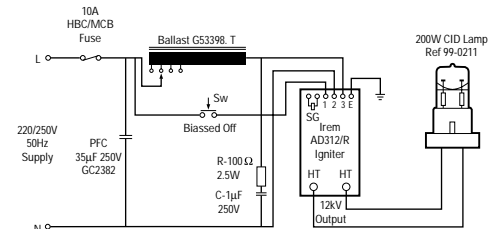

Sw - Normally open contacts - Manual switch or 2 second ON timer
Maximum cable capacitance between igniter and lamp - 30pF (200mm length)

400 Watt CSI Lamp Circuit Diagram

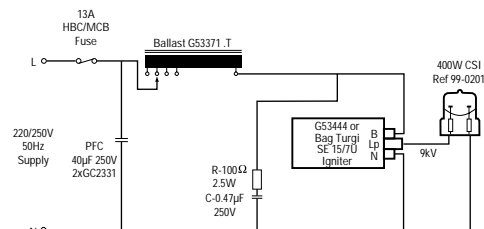

Maximum cable capacitance between igniter and lamp - 50pF (300mm length)

575 Watt CID Lamp Circuit Diagram

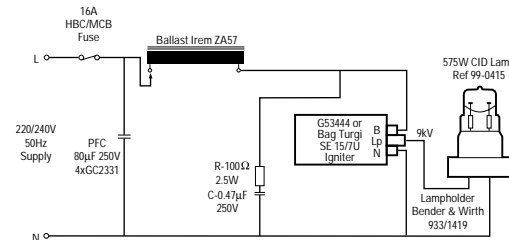

Maximum cable capacitance between igniter and lamp - 50pF (300mm length)

1000 Watt CSI Lamp Circuit Diagram

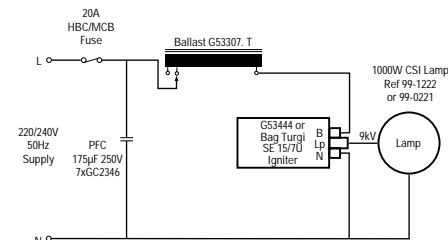

Lampholder for 99-1222 - Bender & Wirth 938/223 and for 99-0221 - Bender & Wirth 933/1419
Maximum cable capacitance between igniter and lamp - 50pF (300mm length)
Replace G53445 (or Bag Turgi SE600/D) igniter sparkgap element when replacing a failed lamp

Discharge lamps continued

1000 Watt CID Lamp Circuit Diagram

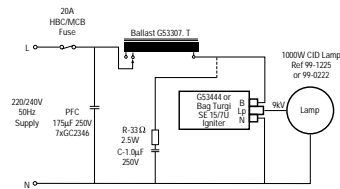

Lampholder for 99-1222 - Bender & Wirth 938/223 and for 99-0222 - Bender & Wirth 933/1419
 R/C components necessary ONLY when used on a 220V rate supply
 Maximum cable capacitance between igniter and lamp - 50pF (300mm length)
 Replace G53445 (or Bag Turgl SE600/D) igniter sparkgap element when replacing a failed lamp

1000 Watt CSI/CID Hot-Restart Lamp Circuit Diagram

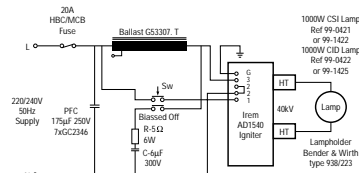

Sw - Normally open contacts - Manual switch or 2 second ON timer
 Maximum cable capacitance between igniter and lamp - 30pF (200mm length)

1200 Watt CID Hot-Restart Lamp Circuit Diagram

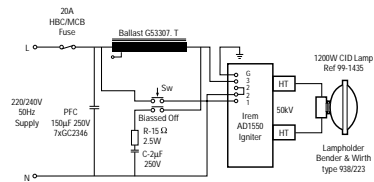

Sw - Normally open contacts - Manual switch or 2 second ON timer
 Maximum cable capacitance between igniter and lamp - 30pF (200mm length)

2500 Watt CID Hot-Restart Lamp Circuit Diagram

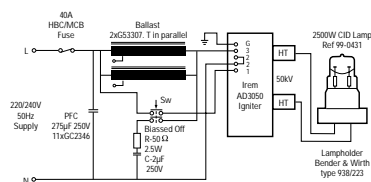

Sw - Normally open contacts - Manual switch or 2 second ON timer
 Maximum cable capacitance between igniter and lamp - 30pF (200mm length)

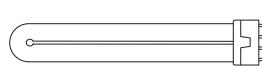
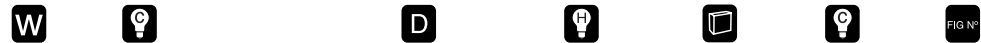

Fig. 1



Fig. 2

Cinema Lamps



Cinema High Lumen Biax™

| 36 | F36BX/CINEMA32 | Indoor | 10000 | 10 | 15816 | 1 |
|----|----------------|----------|-------|----|-------|---|
| 36 | F36BX/CINEMA56 | Daylight | 10000 | 10 | 15819 | 1 |
| 55 | F55BX/CINEMA32 | Indoor | 10000 | 10 | 15811 | 1 |
| 55 | F55BX/CINEMA56 | Daylight | 10000 | 10 | 15814 | 1 |





Cinema Lamps 32 & 55

| T8 | | | | | | |
|----|--------------------|----------|-------|----|-------|---|
| 15 | F15T8/CINEMA32 | Indoor | 7500 | 24 | 15722 | 2 |
| 15 | F15T8/CINEMA55 | Daylight | 7500 | 24 | 15723 | 2 |
| 15 | F15T8/CINEMA32/CVG | Indoor | 7500 | 24 | 15800 | 2 |
| 15 | F15T8/CINEMA55/CVG | Daylight | 7500 | 24 | 15801 | 2 |
| 17 | F17T8/CINEMA32 | Indoor | 15000 | 24 | 15724 | 2 |
| 17 | F17T8/CINEMA55 | Daylight | 15000 | 24 | 15725 | 2 |
| 17 | F17T8/CINEMA32/CVG | Indoor | 15000 | 24 | 15806 | 2 |
| 17 | F17T8/CINEMA55/CVG | Daylight | 15000 | 24 | 15810 | 2 |
| 32 | F32T8/CIN55 | Daylight | 20000 | 36 | 47869 | 2 |
| 32 | F32T8/CIN32 | Indoor | 20000 | 36 | 47868 | 2 |
| 32 | F32T8/CIN55/CVG | Daylight | 20000 | 36 | 47882 | 2 |
| 32 | F32T8/CIN32/CVG | Indoor | 20000 | 36 | 47881 | 2 |

CVG = These lamps feature GE's exclusive CovRguard coating

Cinema Lamps 32 & 55 continued





T12

| W |  | D |  |  |  | FIG N° |
|----|---|----------|---|---|---|--------|
| 20 | F20T12/CINEMA32 | Indoor | 9000 | 24 | 15558 | 2 |
| 20 | F20T12/CINEMA55 | Daylight | 9000 | 24 | 15710 | 2 |
| 20 | F20T12/CINEMA32/CVG | Indoor | 9000 | 24 | 15766 | 2 |
| 20 | F20T12/CINEMA/55CVG | Daylight | 9000 | 24 | 15774 | 2 |
| 30 | F30T12/CINEMA32 | Indoor | 15000 | 24 | 15714 | 2 |
| 30 | F30T12/CINEMA55 | Daylight | 15000 | 24 | 15715 | 2 |
| 30 | F30T12/CINEMA32/CVG | Indoor | 15000 | 24 | 15779 | 2 |
| 30 | F30T12/CINEMA/55/CVG | Daylight | 15000 | 24 | 15780 | 2 |
| 35 | F20T12/CINEMA32/HO | Indoor | 7000 | 24 | 15712 | 2 |
| 35 | F20T12/CINEMA55/HO | Daylight | 7000 | 24 | 15713 | 2 |
| 35 | F20T12/CINEMA32/HO/CVG | Indoor | 7000 | 24 | 15775 | 2 |
| 35 | F20T12/CINEMA55/HO/CVG | Daylight | 7000 | 24 | 15776 | 2 |
| 40 | F40T12/CIN55 | Daylight | 20000 | 30 | 47864 | 2 |
| 40 | F40T12/CIN32 | Indoor | 20000 | 30 | 47857 | 2 |
| 40 | F40T12/CIN55/CVG | Daylight | 20000 | 30 | 47877 | 2 |
| 40 | F40T12/CIN32/CVG | Indoor | 20000 | 30 | 47876 | 2 |
| 75 | F40T12/CINEMA32/HO | Indoor | 12000 | 30 | 15716 | 2 |
| 75 | F40T12/CINEMA55/HO | Daylight | 12000 | 30 | 15717 | 2 |
| 75 | F40T12/CINEMA32/HO/CVG | Indoor | 12000 | 30 | 15782 | 2 |
| 75 | F40T12/CINEMA55/HO/CVG | Daylight | 12000 | 30 | 15783 | 2 |

CVG = These lamps feature GE's exclusive CovRguard coating

Cinema Lamps 32 & 55 continued

T12

| W |  | D |  |  |  | FIG N° |
|-----|---|----------|---|---|---|--------|
| 85 | F72T12/CINEMA32/HO | Indoor | 12000 | 15 | 15718 | 2 |
| 85 | F72T12/CINEMA55/HO | Daylight | 12000 | 15 | 15719 | 2 |
| 85 | F72T12/CINEMA32/HO/CVG | Indoor | 12000 | 15 | 15785 | 2 |
| 85 | F72T12/CINEMA55/HO/CVG | Daylight | 12000 | 15 | 15786 | 2 |
| 110 | F96T12/CINEMA32/HO | Indoor | 12000 | 15 | 15720 | 2 |
| 110 | F96T12/CINEMA55/HO | Daylight | 12000 | 15 | 15721 | 2 |
| 110 | F96T12/CINEMA32/HO/CVG | Indoor | 12000 | 15 | 15794 | 2 |
| 110 | F96T12/CINEMA55/HO/CVG | Daylight | 12000 | 15 | 15798 | 2 |

Fluorescent Cinema Lamps - life on rapid start ballast

CVG = These lamps feature GE's exclusive CovRguard coating

Blacklight Blue (produce long wave ultra-violet light)

T12

| W |  |  | D |  |  |  | FIG N° |
|----|---|---|-----------------|---|---|---|--------|
| 20 | 600 | F20T12/BLB | Blacklight Blue | 9000 | 6 | 34747 | 2 |
| 40 | 1200 | F40BLB | Blacklight Blue | 20000 | 6 | 25618 | 2 |

Technical information

| | |
|--------------------------------|-----------|
| Explanation of codes | 83 - 86 |
| Glossary | 87 - 90 |
| Operating notes | 91 - 92 |
| Health and safety guide | 93 - 96 |
| Filament & cap designations | 97 - 98 |
| Lamp comparison / construction | 99 - 105 |
| Lamp performance | 106 - 109 |
| Surge current | 110 - 111 |
| Discharge lamps | 112 - 117 |

Explanation of codes

Lamps listed in this catalogue are those designed for use as follows:

A1 Prefix - L.I.F. (Lighting Industries Federation) reference indicates lamps which were primarily designed for use with slide, film and overhead projectors.

ANSI Codes - These are 3-letter codes assigned by the American National Standards Institute. They provide a system for assuring mechanical and electrical interchangeability among similarly coded lamps from various manufacturers.

CP Prefix - Lamps designed for use in conjunction with film balanced for 3200K. These are single ended types intended for use in Fresnel/ellipsoidal luminaires etc.

P2 Prefix - Again for use with 3200K film stock for open faced luminaires and video sun guns.

P1 Prefix - For use with 3400K film stock.

T Prefix - Lamps intended for theatre luminaire applications. These are of lower colour temperature (2900 - 3050K) and longer life than the often similar CP types above.

C.S.I. - Discharge lamps with a colour temperature of around 4000K for outside broadcast and follow spot use.

C.I.D. - Discharge lamps with a colour temperature of 5500-6000K for location filming and applications such as disco lighting where a very bright compact source is required.

Special and Experimental Lamps

In addition to these standard ranges, a number of similar types are available to special order and in most cases, a minimum order quantity will apply. These include non-standard voltage ranges of some types e.g. 100V, 100/115V, 120V and also a number of types which have the GE "HX" or "THE" prefix.

Lamp Bases

The listings use the IEC International designations for lamp bases. Where appropriate, alternative local descriptions are appended.

Incandescent tungsten halogen lamps

Filament Format

The listings use the following codings for filament shape:

S.C. - Axial Single Coil - equivalent to ANSI C8

C.C. - Axial Coiled Coil - equivalent to ANSI CC8

M.P. - Monoplane Grid - equivalent to ANSI C13

B.P. - Biplane Grid - equivalent to ANSI C13D

T.F. - Twin Monoplane Grid - equivalent to ANSI 2C13

S.C.H. - Single Coil Hexagonal - equivalent to ANSI 6-C8

S.C.S. - Single Coil Square - equivalent to ANSI 4-C8

CP Range of Lamps for Fresnel and Spotlight Fittings

As the result of extensive and sustained development work, much of it original, GE are able to offer a comprehensive range of lamps of quartz construction, operating on the tungsten halogen principle for all Television Studio, 'motion picture', and Theatre lighting purposes.

GE has been strongly supported by the television and film industries in its decision to discontinue glass lamps for studio lighting purposes. This is because the industry has appreciated the financial advantages of quartz halogen lamps, their reliability and virtually constant colour temperature.

The increase in the use of the lamps we now manufacture is due to the GE policy of exploiting the important advantages of compact size offered by quartz halogen construction.

As a result GE are able to supply quartz halogen lamps for use in Fresnel and spotlight fittings from 300 watts to 24,000 watts. These lamps employ a wide range of commonly accepted bases. This gives fittings manufacturers a comprehensive range of compact lamps and permits the construction of smaller, lighter and more efficient luminaires.

Glossary of basic product information

Rated Average Life

Average life ratings of Projection Lamps are based on closely controlled laboratory tests of lamps, at their rated voltage, over a long period of production time. Rated Average Life is not necessarily the same as service life; mechanical shock and vibration, voltage fluctuation, temperature and other environmental factors may result in shorter service life. As with any average value, some individual lamps may operate longer, and some may operate shorter, than their Rated Average Life. (Supply voltage variation can significantly affect lamp life; see comments under Lamp Life Ratings, page 107).

'T' Class Lamps for Theatre Spotlight Fittings

With this group of lamps GE are continuing their policy of developing quartz halogen lamps. These lamps operate at a lower colour temperature than the CP range. An average life of a remarkable 750 hours is achieved for most of the GE range. Similar cost savings to those offered by quartz halogen CP lamps are now presented by the quartz halogen 'T' range.

Typical Working Distance

For Multi-Mirror® and other reflector lamps and MARC™ lamps, the Working Distance shown is the distance from the front surface of the reflector rim to the film plane, in the optical system for which the lamp was first designed. In most cases, it provides a uniform plane of light for the intended aperture.

Light Centre Length (LCL)

This dimension defines the location of the filament in relation to the lamp base. It is measured from the geometric centre of the filament to a specified point on, or plane through, the base. Light Centre Length is subject to manufacturing tolerances.

Maximum Overall Length (MOL)

This dimension includes the lamp bulb and all rigid parts of the base. Since the listed lengths include maximum tolerances, actual lamps are generally slightly shorter.

Approximate Initial Lumens

The value shown is based on spherical photometry, at rated voltage, of lamps that have been seasoned for approximately 15% (or a minimum of 2 hours) or more of their rated average life.

Approximate Colour Temperature

The radiation within the visible spectrum from tungsten filament lamps is similar in spectral distribution to that from a “blackbody” at specific colour temperatures. The Colour Temperatures shown are approximate initial values in Kelvin (K) for lamps operated at rated voltage. As the spectral distribution of MARC lamps does not conform to that of a “blackbody”, the values shown are ‘correlated’ colour temperatures expressed in Kelvin.

Important Notice

This catalogue contains accumulated data to February 2003. Additional information is constantly being uncovered through research and testing, which may modify the data given herein. This is particularly true of newer lamps. For the latest lamp design data and information, contact your General Electric Lamp Representative.

The data and suggested applications contained in this catalogue, as well as any additional information our representative may be able to furnish, are for general information only and are not intended and should not be taken as representations or warranties as to the suitability of a lamp for any particular attention or use in any particular equipment, nor are our representatives authorised to make any such representations or give any such warranties. Applications and conditions of use are many and varied, and beyond our control. We cannot possibly have the same degree of knowledge that the purchaser has with respect to the design of their equipment and the conditions of its use. Therefore, it is up to the purchaser to make their own determination as to the suitability of a lamp for his intended application or use and to assume the responsibility for that determination.

General Electric desires to supply the best possible products at all times. For this reason, General Electric reserves the right to make changes in its products when it believes such changes will improve its products.

Operating Notes

Caution notices are included with all lamps. Users are urged to read and comply with these.

Operating precautions

All lamps in this catalogue must be operated with a series fuse in the circuit, as directed in the Technical Digest.

Lamps of quartz construction use a gas filling at a pressure higher than atmospheric and as the lamp can in rare instances shatter in use, suitable shielding techniques should be employed where appropriate. Also protect the lamp from mishandling, scratches and abrasions, and do not operate at above correct rated voltage.

Operating position

For good performance lamps must be used within specified limitations on operating position. The following abbreviations are used in the lamp tables to indicate these limits:

BD - Base Down. Operate only vertical, base down.

BU - Base Up. Operate only vertical, base up.

BDTH - Base Down To Horizontal. Do not operate with base above horizontal.

Horiz. - Horizontal. Operate only in horizontal position.

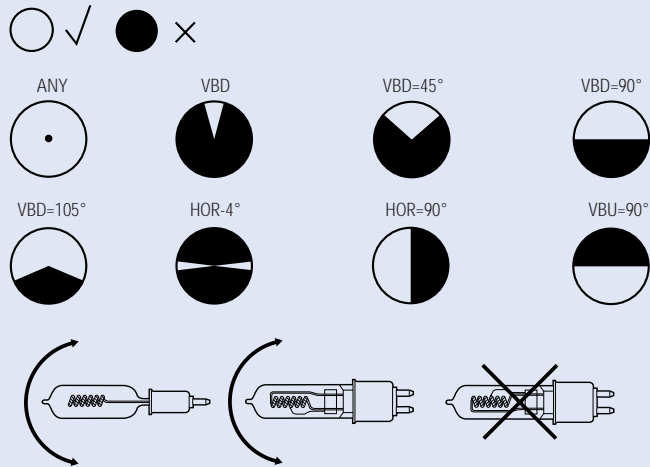

Fig. 1

Axial coiled coil single ended lamps will generally give better reliability against premature arcing if orientations in which the main support spine is under the filament are avoided.

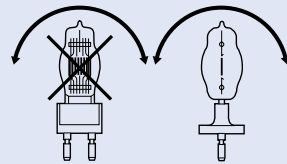

Fig. 2

The lamp must not be rotated in the filament plane (or electrode plane).

Health and safety guide

Instructions for PAR64, PAR56, Closed Stage & Studio lamps Stage & Studio and Unshielded lamps

- 1 Disconnect from power supply before removing and/or replacing lamp or fuse
- 2 Install by holding the lamp cap and if necessary wear eye protection.
- 3 If the lamp is handled, clean before operation with lint free cloth moistened with alcohol or Methylated Spirits.
- 4 Avoid improper operation of the lamp e.g. at over voltage or at burning angles not designated for the lamp type or rating. Operate in series with a quick acting high breaking capacity fuse of suitable rating. Non observation of these points may damage the lamp or equipment.
- 5 In operation:
 - (a) lamps develop a high internal pressure and could shatter
 - (b) lamps develop a high surface temperature
 - (c) direct exposure may cause UV irritation to skin and eyes

The use of glass or other UV filters is advised if the lamp is used in close proximity for a prolonged period.
Avoid operation in proximity to combustibles
Allow to cool before attempting replacement
- 6 Life expired lamps should be broken in a suitable robust container or wrapping to retain flying fragments. There is a toxic content in the fill gas and larger quantities should only be broken in a well ventilated area
- 7 Always check that replacement lamps are the correct type for the application and that rating, cap and control gear are correct
- 8 Lamps having outer bulbs must not be operated if the outer glass is broken

ANSI notice for PAR64, Super PAR64, PAR56, Closed Stage & Studio lamps

Warning

- Risk of electric shock
Turn power off before inspection, installation or removal.
- Risk of fire
Keep combustible materials away from lamp.
Use in fixture rated for this product.
- A damaged lamp emits UV radiation which may cause eye / skin injury
Turn power off if glass bulb is broken. Remove and dispose of lamp.
- Pressurized lamp – unexpected rupture may cause injury, fire, or property damage
Do not exceed 110% of rated voltage.
Avoid direct water / liquid contact.
Use in enclosed fixture rated for this product.
Do not use lamp if outer glass is scratched or broken.

Caution

- Risk of burn
Allow lamp to cool before handling.
Turn power off before installing lamp.
- Lamp may shatter and cause injury if broken
Do not use lamp if outer glass is scratched or broken
Dispose of lamp in a closed container

ANSI notice for Stage & Studio unshielded lamps

Warning

- Risk of electric shock
Turn power off before inspection, installation or removal
- Risk of fire
Keep combustible materials away from lamp
Use in fixture rated for this product.
- Pressurized lamp – unexpected rupture may cause injury, fire, or property damage
Do not exceed 110% of rated voltage.
Do not touch glass with bare hands
Use in enclosed fixture rated for this product.
Do not use lamp if outer glass is scratched or broken.
Operate lamp only in specified position.

Caution

- Risk of burn
Allow lamp to cool before handling.
Turn power off before installing lamp.
- Lamp emits UV radiation which may cause eye / skin irritation. RG-2
Limit unshielded exposure to less than 15 minutes per day.
- Lamp may shatter and cause injury if broken
Wear safety glasses and gloves when handling lamp.
Do not use lamp if outer glass is scratched or broken.
Dispose of lamp in a closed container.

Additional Special Precautions for the Operation of Metal Halide Discharge Lamps

- 1 Check that replacement lamp is correct type for the application, that rating, cap and control gear are correct.
- 2 Lamps having outer bulbs must not be operated if the outer glass is broken.
- 3 Instructions given with metal halide lamps must be carefully followed in all respects. Protection against the explosion of lamp must be maintained, do not remove any covering or shields until the lamp is located in an approved enclosed housing.
- 4 Certain lamps generate ozone in use and should be operated only in well ventilated locations.
- 5 Metal halide lamps with quartz envelopes without glass outer bulbs may emit short wave ultra violet radiation which is harmful to eyes and skin. Operators must be shielded from direct or indirect short wave ultra violet radiation.

Filament designation

The configuration of the filaments in all tungsten filament lamps is identified by a prefix letter or letters, followed by a number. The letter indicates whether the wire is a single coil (C) or coiled coil (CC); the number indicates the form or arrangement of the coil on its support structure. Note that the illustrations are not to scale.

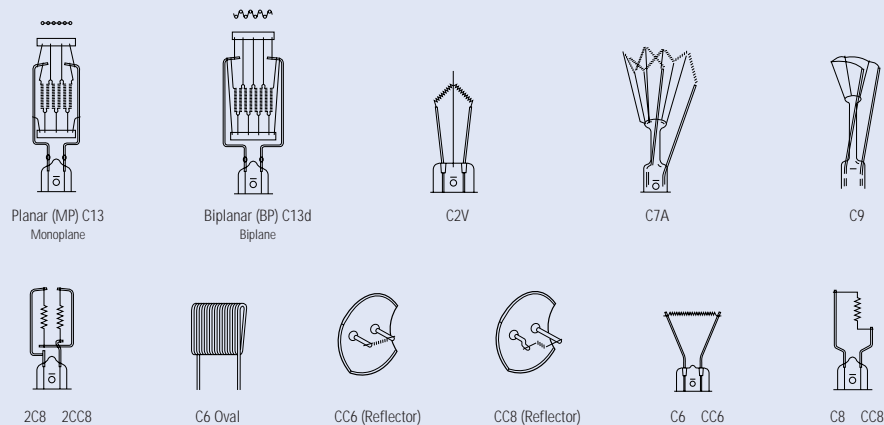

Lamp caps

Typical caps used on the Photographic lamps listed in this catalogue are shown below along with their IEC codes and normal names or common abbreviations. The IEC codes are used in the majority of table entries. Note that the illustrations are not to scale.

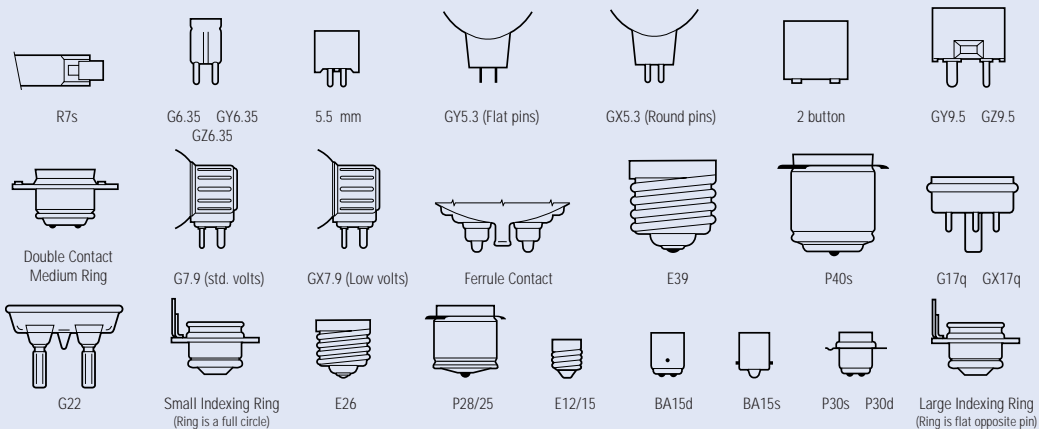

Lamp Comparison and Construction

Lamps for Ellipsoidal Spotlights

A problem is encountered with some ellipsoidal spotlight luminaires due to the fact that a portion of the reflected beam of light is directed onto the cap of the lamp designed for Fresnel fittings. This leads to overheating of the cap and seal which may result in premature lamp failure.

GE have therefore designed lamps intended for use in ellipsoidal spotlights where the size of the cap has been reduced and the neck length correspondingly increased, thus removing the critical seal area from the reflected radiation and ensuring that optimum lamp life is obtained.

Linear and 'U' Lamps - for Studio Lighting 3200K

Whilst a comprehensive selection of lamps for spotlight fittings is important to the lighting director, of almost equal importance is a range suitable for the many different fittings now on the market which use tungsten halogen lamps of tubular construction. GE believe their range gives a wide choice and is unmatched in performance and reliability.

Hard glass Halogen compared with Quartz Halogen

The tungsten halogen principle is now so well known and documented elsewhere that it is considered unnecessary to describe it here. However should you require details of this principle then please contact GE Lighting Ltd or your nearest Subsidiary Company. It is important to distinguish between hard glass lamps that merely have a halogen compound added to the filling gas and lamps such as those enumerated, which are of quartz construction. The former are from the point of view of life and performance identical to conventional glass lamps of the same rating, the halogen only serving to prolong the usefulness of the lamp by preventing internal blackening due to evaporated tungsten. However, once a lamp is constructed from quartz with its higher melting point, instead of glass, the designer can make use of the much greater strength of the small envelope. It is then possible to increase the filling pressure which by reducing tungsten evaporation from the filament prolongs the life of the lamp to at least twice that of a glass lamp of equivalent efficacy.

Biplane or Monoplane?

The filament format of a lamp will have an effect on the beam performance of a luminaire.

In Fresnel optics a biplane filament will, due to its smaller area, produce a narrower spot of slightly increased peak intensity, compared to an equivalent monoplane filament. However, in intermediate and flood positions better light collection is obtained from a monoplane source, as the additional light collected by the rear mirror is largely obscured with a biplane source. A wider angle beam for a given intensity is thus provided by a monoplane filament.

Ellipsoidal optics are designed around a specific filament area. Larger areas will allow some of the light to fall outside the gate and be lost. A smaller filament area will concentrate the light on the centre of the gate producing a hot spot. The choice between a monoplane and a smaller equivalent biplane is, therefore, dependent on luminaire design and customer preference.

GE pursue a policy of allowing the customers to make this choice by offering both monoplane and biplane versions of relevant lamp types.

Arc Prevention in Tungsten Halogen Studio Lamp Applications

Almost all production personnel in the film and television industry have at some time encountered sudden failure of incandescent studio lamps. When this occurs at a crucial moment and forces a re-shoot the cost can be considerable.

The significant features of these failures were that they almost always occurred during the first 20 hours of use and the incidence of failure increased with operating temperatures. Failure invariably resulted from an arc across the filament plugs which destroyed the tails of the filament.

Tungsten halogen lamps are gas filled. The introduction of hydrogen is predicted to react with the halogen to 'slow down' the tungsten halogen cycle. In addition it is known that hydrogen will slowly diffuse through the hot quartz bulb so that the hydrogen concentration would gradually diminish.

The rate of loss of hydrogen during lamp operation is less than previously predicted and based upon spectroradiometer measurements and calculations, maximum protection is only required during the initial 50 hours of life. Hence the use of hydrogen additions is the most advantageous method of ensuring reliable operation of lamps during early life, particularly in demanding operating conditions.

GE Lighting offer lamps with proprietary hydrogen addition*. This offers adequate arcing protection without significantly interfering with the halogen cycle.

*owned by GE under US PAT #4743802

Lamp performance as a function of operating voltage

Tungsten halogen lamp performance (light output, power consumption, life, colour, temperature) is a strong function of operating voltage. The rated performances claimed in this catalogue have been achieved at nominal rated volts. Operating the lamps at other than the rated voltage will significantly affect performance, as shown graphically on pages 106 and 107. All lamps are designed for use with proprietary dimming equipment as required.

Lamp comparison and construction

A typical high wattage studio lamp

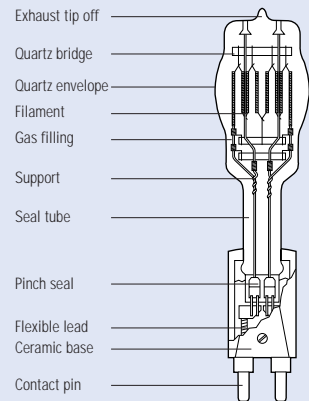

A typical 4 pin twin filament studio lamp

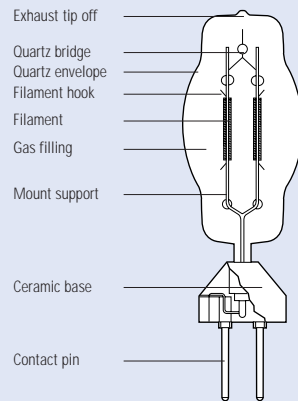

A typical low wattage theatre class tungsten halogen lamp

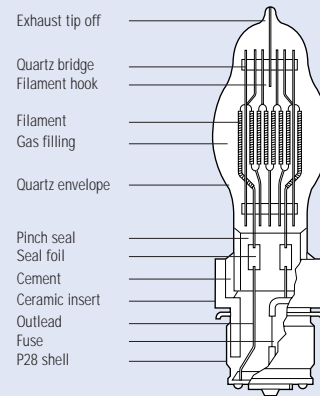

End section of a typical quartz linear tungsten halogen lamp

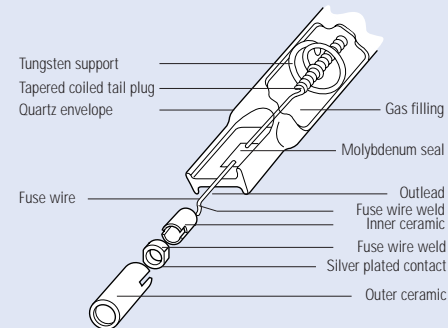

Lamp performance

Variation of light output and wattage with applied voltage for a typical studio lamp

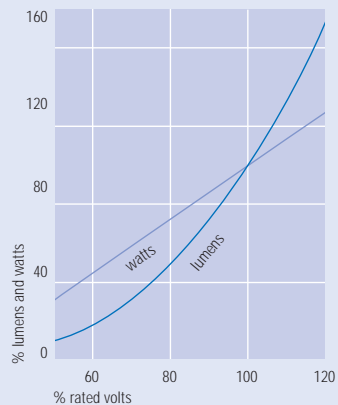

Colour temperature variation with voltage for typical studio lamp

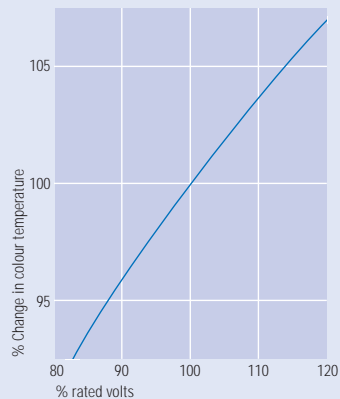

Typical life variation against operation voltage

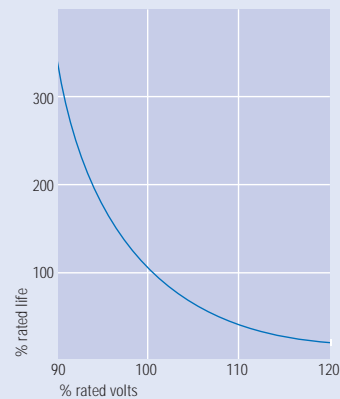

Spectral distribution of luminous flux (lumens) for typical theatre and studio lamp

Calculations of lamp life achievement taken from this graph should be considered strictly theoretical as the life factor is considerably influenced by frequency of switching, environment, vibration, handling, cleaning etc. This graph is based on the average achievement of numerous lamp tests, and thus should only be used as an approximate guide to performance.

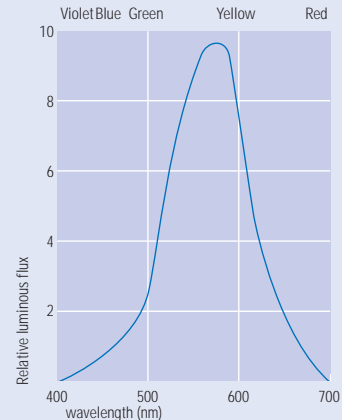

Total spectral energy distribution of typical studio lamp

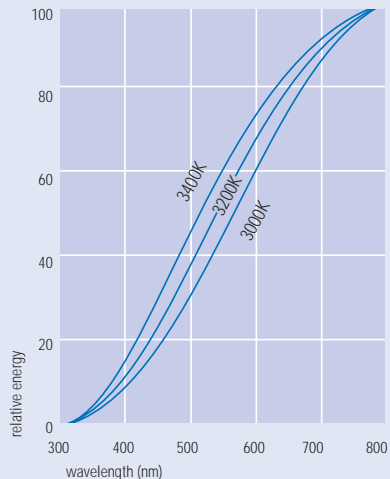

Spectral energy distribution can be shown in absolute terms whereas radiation in terms of visible light is related to the response of the human eye. (Spectral distribution chart on previous page)

Operating Temperature of Tungsten Halogen Studio Lamps

The following maximum and minimum temperatures are suggested for optimum life. Operation outside these figures will not necessarily cause immediate failure but will affect life adversely to an increasing extent.

Seal - 450°C maximum

Above this figure the sealing foil oxidises at a rate increasing with temperature and is frequently the cause of short life due to seal failure.

Bulb - 250° - 800°C

Outside this range the halogen cycle becomes less efficient and blackening may occur. Temperatures above 1200°C will cause the bulb to soften.

Pins - 350°C maximum

Above this figure the plating on the pins may lose adhesion and the contact will deteriorate. Such deterioration may form local hot spots which rapidly worsen and may result in arcing and irreparable damage to both lamp and holder. Should signs of this be evident on removal of a failed lamp, it is important that a good contact is restored by replacing the lampholder before the next lamp is fitted. Otherwise the new lamp will rapidly fail in a similar manner.

Turn on time of studio lamps

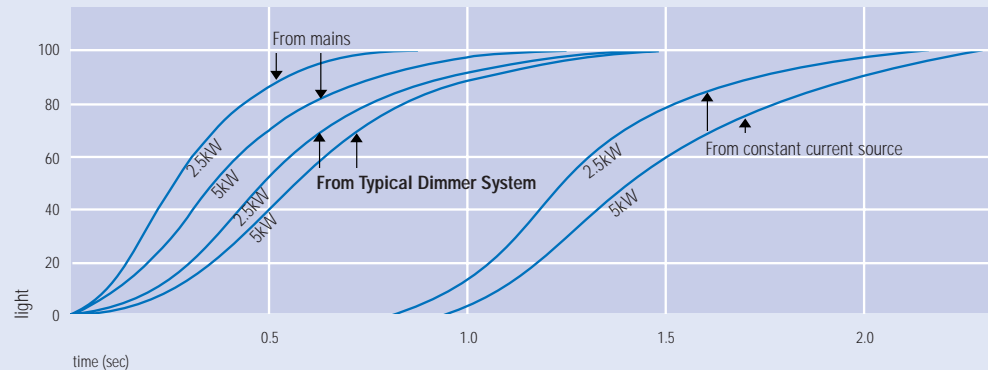

Surge Current

The cold resistance of a halogen studio lamp is approx. 1/17 of its value in normal operation. On switch on, theoretically a surge current of $17\sqrt{2}$ x the normal current would flow and depending on the thermal mass of the filament* this will fall to the lamp normal current in approx. 1 sec. In practice this maximum theoretical current does not appear due to (a) switch on does not always occur at the peak of the AC voltage, (b) the supply has some impedance which is comparable with the cold resistance of high wattage lamps, i.e. maximum possible surge current where V is the applied voltage and Z is the sum of the lamp cold resistance and the supply impedance.

Typically supply impedance is the order of 0.3 ohm and lamp life is based on testing with such a supply. In the rare cases where the line impedance is lower than this figure, an adverse effect on life may be encountered particularly with high wattage types, due to the then extremely high surge current on switching.

| lamp | type | cold resistance (ohms) | max. surge current (amps) line impedance = | | | | normal operating current |
|------|------|------------------------|---|----------|----------|----------|--------------------------|
| | | | 0 ohms | 0.1 ohms | 0.3 ohms | 0.5 ohms | |
| 240V | 10kW | 0.34 | 1000 | 774 | 530 | 405 | 41.5 |
| 240V | 5kW | 0.7 | 486 | 424 | 340 | 283 | 20.8 |
| 115V | 5kW | 0.15 | 1085 | 650 | 360 | 250 | 43.5 |
| 240V | 2kW | 1.7 | 200 | 189 | 170 | 154 | 8.35 |
| 117V | 2kW | 0.41 | 404 | 324 | 233 | 182 | 17.1 |
| 240V | 1kW | 3.4 | 100 | 97 | 92 | 87 | 4.15 |

Fusing of Tungsten Halogen Studio and Theatre Lamps

A lamp normally fails at end of life by fusing of the filament. Often an arc then forms and as there is little resistance to limit the current this rises to a very high value which if maintained can result in a serious overload on the envelope and seals. This might result in the lamp shattering. A quick acting high breaking capacity fuse must be connected in the supply line in all applications. Suitable types are given in BS88 (IEC 60269), IEC 60127 or IEC 60241.

| lamp power (watts) | fuse (rated current) (amps) 100-115V | 115-130V | | 220-250V | |
|--------------------|---|------------|--|------------|--|
| | | | | | |
| 500 | 6 | 6 | | 4 | |
| 650 | 10 | 6 | | 4 | |
| 1000 | 16 (15 UK) | 10 | | 6 | |
| 1500 | 20 | 16 (15 UK) | | 10 | |
| 2000 | 25 (30 UK) | 25 (20 UK) | | 10 | |
| 2500 | 35 (30 UK) | 25 (30 UK) | | 16 (15 UK) | |
| 5000 | 63 (60 UK) | 50 | | 25 (30 UK) | |
| 10000 | 125 | 100 | | 50 | |

Discharge lamps

Even with all the advances which have been made in tungsten halogen technology in recent years there are still occasions, particularly whilst working on location, when handling the number of fittings required to give an acceptable illumination level can be a logistical headache.

One GE metal halide discharge lamp can provide more light than three tungsten halogen lamps of the same rating. That means one third the power consumption and one third the number of fittings to transport and aim. The potential for major cost savings is clear.

GE Lighting has led the way in adapting discharge lamps for use in the performing arts. The company was the first and for many years the only manufacturer to offer metal halide lamps in the compact, single ended capsule format. The minimal dimensions of these lamps can be incorporated into fittings which are much smaller than corresponding luminaires using double ended lamps of the same power. With a near point light source excellent optical control is possible.

Compact iodide lamps are also available in a sealed beam format. With the light source carefully positioned in the reflector, optimum optical performance is guaranteed.

The nitrogen filling gas in the outer bulb prevents oxygen attacking the seal of the inner capsule and so increases the life of the lamp dramatically.

All CID discharge studio and stage lamps are dimmable to 50% of peak lumens and the great majority are available in hot re-strike versions for applications where frequent changes in lighting levels are required. All lamps will re-strike within ten minutes of switch off.

Compact Iodide Daylight (CID) Discharge Lamps

With a colour temperature of 5500K these lamps provide an excellent simulation of daylight. For location filming, colour matching with natural light presents no problem.

In the studio, interior scenes can be given a realistic appearance. As relatively small numbers of lamps are required the amount of heat generated is substantially less than under tungsten halogen lamps giving the same illumination. For all personnel the working environment is much more comfortable. Of course, the running costs are correspondingly lower too.

In the theatre CID discharge lamps are particularly useful in follow spotlights. The very high light output from a point source creates a very intense, sharp beam.

Compact Source Iodide (CSI) Discharge Lamps

CSI lamps offer all the advantages of the CID range, but operate at the warmer colour temperature of 4000K. This allows the lamps to be readily blended with tungsten halogen lighting.

Compact Source Special (CSS) Discharge Lamps

These lamps are specially developed for disco and fibre optics applications. Life may be extended if fan or forced cooling is used.

CSR

High efficiency compact arc cold start metal halide lamps.

CSR HR

High efficiency compact arc hot start metal halide lamps.

CSD

Long life compact arc metal halide lamps with high colour temperature.

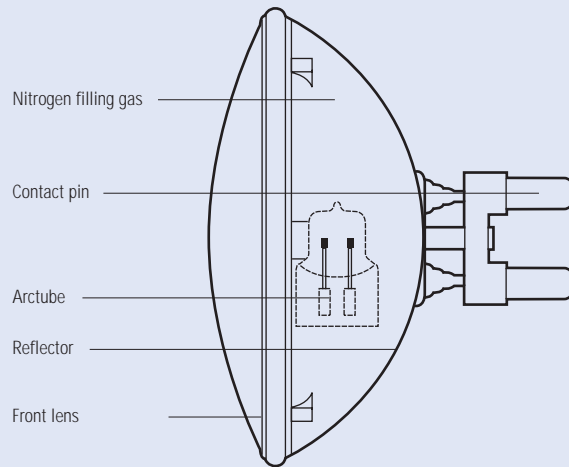
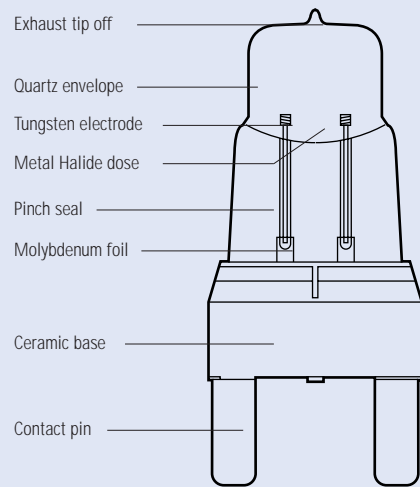

Operating Temperature of Discharge Studio Lamps

The following maximum and minimum temperatures are suggested for optimum life. Operation outside of these figures will not necessarily cause immediate failure but will effect life adversely to an increasing extent.

Cap/bulb interface capsule lamps - 450° maximum

Above this figure the sealing foil oxidises at a rate increasing with temperature and is frequently the cause of short life due to seal failure.

Bulb

capsule lamps 700° - 1000°C

sealed beam lamps 150° - 400°C

Above 1000°C, quartz may devitrify, which will cause the arc tube to leak, loss of dose will cause the arc tube to operate below the minimum temperature, the metal halides will not vaporise as required, and lamp performance will be impaired.

Pins - 350°C maximum

Above this figure the plating on the pins may lose adhesion and the contact will deteriorate. Such deterioration may form local hot spots which rapidly worsen and may result in arcing and irreparable damage to both lamp and holder. Should signs of this be evident on removal of a failed lamp, it is important that a good contact is restored by replacing the lampholder before the next lamp is fitted, otherwise the new lamp will rapidly fail in a similar manner.

N.B. For sealed beam lamps - to ensure that the above conditions are met, it is important that the lamp does not operate above 400°C even in an enclosed fitting.

Fusing of Discharge Studio and Theatre Lamps

A quick acting high breaking capacity fuse must be connected in the supply line in all applications. Suitable types are given in BS88 (IEC 60269), IEC 60127 or IEC 60241. See page 111 for suitable fuse ratings.

Spectral distribution of luminous flux (lumens) for CSI discharge lamps

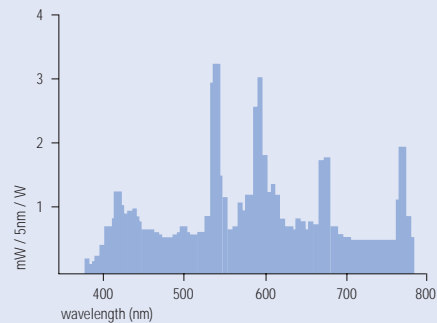

Spectral distribution of luminous flux (lumens) for CID discharge lamps

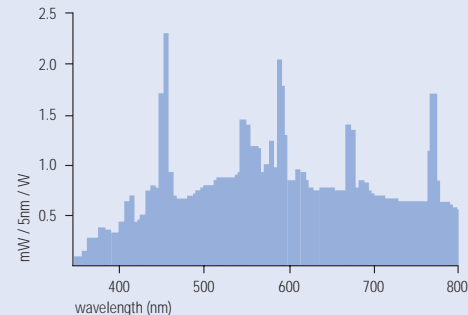

Index

Lamp type page

PAR lamps by order code

| Lamp type | page | Audio visual | Micrographic | Photographic | Theatre / Stage | Disco | TV / Film / Studio | Outside Broadcast |
|---------------|------|--------------|--------------|--------------|-----------------|-------|--------------------|-------------------|
| 25PAR36 | 7 | | | | • | | | |
| 25PAR36/NSP | 7 | | | | • | | | |
| 25PAR36/WFL | 7 | | | | • | | | |
| 25PAR36/VWFL | 7 | | | | • | | | |
| 50PAR36/VNSP | 7 | | | | • | | | |
| 50PAR36/NSP | 7 | | | | • | | | |
| 50PAR36/WFL | 7 | | | | • | | | |
| 50PAR36/VWFL | 7 | | | | • | | | |
| 50PAR36/WFL/H | 7 | | | | • | | | |
| 150PAR46/3MFL | 10 | | | | • | | | |
| 200PAR46/3MFL | 10 | | | | • | | | |
| 120PAR56/VNSP | 11 | | | | • | | | |
| 120PAR56/MFL | 11 | | | | • | | | |
| 120PAR56/WFL | 11 | | | | • | | | |
| 200PAR | 11 | | | | • | | | |
| 240PAR56/VNSP | 11 | | | | • | | | |
| 240PAR56/MFL | 11 | | | | • | | | |
| 240PAR56/WFL | 11 | | | | • | | | |

Lamp type page

| Lamp type | page | Audio visual | Micrographic | Photographic | Theatre / Stage | Disco | TV / Film / Studio | Outside Broadcast |
|-----------------|------|--------------|--------------|--------------|-----------------|-------|--------------------|-------------------|
| 300PAR56/NSP | 12 | | | | • | | | |
| 300PAR56/MFL | 12 | | | | • | | | |
| 300PAR56/WFL | 12 | | | | • | | | |
| 500PAR64/NSP | 17 | | | | • | | | |
| 500PAR64/MFL | 17 | | | | • | | | |
| Q500PAR56/NSP | 12 | | | | | • | | |
| Q500PAR56/MFL | 12 | | | | | • | | |
| Q500PAR56/WFL | 12 | | | | | • | | |
| Q500PAR64/VNSP | 15 | | | | | • | | |
| Q500PAR64/NSP | 15 | | | | | • | | |
| Q500PAR64/MFL | 15 | | | | | • | | |
| 500PAR64/WFL | 15 | | | | | • | | |
| 500PAR64/MFL | 15 | | | | | • | | |
| Q1000PAR64/NSP | 17 | | | | | | • | |
| Q1000PAR64/MFL | 17 | | | | | | • | |
| Q1000PAR64/VNSP | 17 | | | | | | • | |
| DWE | 8 | | | | | | • | |
| EXC | 15 | | | | | • | | |
| EXD | 15 | | | | | • | | |

| Lamp type | page | Audio visual | Micrographic | Photographic | Theatre / Stage | Disco | TV / Film / Studio | Outside Broadcast |
|-----------|------|--------------|--------------|--------------|-----------------|-------|--------------------|-------------------|
| EXE | 15 | | | | | | | |
| EXG | 15 | | | | | | | |
| FBE | 8 | | | | | | | |
| FBO | 8 | | | • | | | | |
| FCX | 6 | | | | | | | |
| FCW | 9 | | | | | | | |
| FFN | 17 | | | • | • | | | |
| FFP | 17 | | | • | • | | | |
| FFR | 17 | | | • | • | | | |
| FFS | 17 | | | • | • | | | |
| FGN | 17 | | | • | | | | |
| 4405 | 7 | | | | | | | |
| 4435 | 9 | | | | | | | |
| 4502 | 7 | | | | | | | |
| 4505 | 7 | | | | | | | |
| 4509 | 7 | | | | | | | |
| 4509X | 7 | | | | | | | |
| 4511 | 7 | | | | | | | |
| 4515 | 7 | | | | | | | |

| Lamp type | page | Audio visual | Micrographic | Photographic | Theatre / Stage | Disco | TV / Film / Studio | Outside Broadcast |
|-----------|------|--------------|--------------|--------------|-----------------|-------|--------------------|-------------------|
| H4515 | 7 | | | | | | | |
| 4516 | 7 | | | | | | | |
| 4531 | 9 | | | | | | | |
| 4535 | 9 | | | | | | | |
| 4537 | 7 | | | | | | | |
| 4537-2 | 9 | | | | | | | |
| 4545 | 11 | | | | | | | |
| 4546 | 7 | | | | | | | |
| 4547 | 7 | | | | | | | |
| 4551 | 9 | | | | | | | |
| 4552 | 13 | | | | | | | |
| 4553 | 9 | | | | | | | |
| Q4554 | 9 | | | | | | | |
| 4559 | 13 | | | | | | | |
| Q4559 | 13 | | | | | | | |
| Q4559X | 13 | | | | | | | |
| 4570 | 9 | | | | | | | |
| 4571 | 9 | | | | | | | |
| 4572 | 9 | | | | | | | |

| Lamp type | page | Audio visual | Micrographic | Photographic | Theatre / Stage | Disco | TV / Film / Studio | Outside Broadcast |
|-----------|------|--------------|--------------|--------------|-----------------|-------|--------------------|-------------------|
| 4580 | 9 | | | | • | | | |
| 4581 | 9 | | | | • | | | |
| 4587 | 8 | | | | • | | | |
| 4591 | 7 | | | | • | | | |
| 4593 | 8 | | | | • | | | |
| 4594 | 8 | | | | • | | | |
| 4595 | 7 | | | | • | | | |
| 4596 | 8 | | | | • | | | |
| 4626 | 8 | | | | • | | | |
| 4627 | 8 | | | | • | | | |
| 4635 | 9 | | | | • | | | |
| Q4597 | 9 | | | | • | | | |
| Q4681 | 9 | | | | • | | | |
| H7604 | 7 | | | | • | | | |
| H7616 | 7 | | | | • | | | |
| H7635 | 9 | | | | • | | | |

| Lamp type | page | Audio visual | Micrographic | Photographic | Theatre / Stage | Disco | TV / Film / Studio | Outside Broadcast |
|----------------------------------|------|--------------|--------------|--------------|-----------------|-------|--------------------|-------------------|
| Theatre lamps by LIF code | | | | | | | | |
| T11 | 25 | | | | • | | | |
| T12 | 25 | | | | • | | | |
| T13 | 29 | | | | • | | | |
| T14 | 29 | | | | • | | | |
| T15 | 29 | | | | • | | | |
| T16 | 35 | | | | • | | | |
| T17 | 28 | | | | • | | | |
| T18 | 23 | | | | • | | | |
| T19 | 25 | | | | • | | | |
| T25 | 23 | | | | • | | | |
| T26 | 23 | | | | • | | | |
| T27 | 23 | | | | • | | | |
| T28 | 28 | | | | • | | | |
| T29 | 25 | | | | • | | | |
| OC1200 | 27 | | | | • | | | |

Lamp type page

TV Film & Studio lamps by LIF code

| Lamp type | page | Audio visual | Micrographic | Photographic | Theatre / Stage | Disco | TV / Film / Studio | Outside Broadcast |
|-----------|------|--------------|--------------|--------------|-----------------|-------|--------------------|-------------------|
| CP23 | 25 | | | | | | • | |
| CP24 | 25 | | | | | | • | |
| CP29 | 31 | | | | | | • | |
| CP30 | 33 | | | | | | • | |
| CP32 | 33 | | | | | | • | |
| CP39 | 27 | | | • | | | • | |
| CP40 | 27 | | | • | | | • | |
| CP41 | 31 | | | • | | | • | |
| CP43 | 26 | | | | | | • | |
| CP51 | 29 | | | | | | • | |
| CP52 | 29 | | | | | | • | |
| CP53 | 35 | | | | | | • | |
| CP58 | 33 | | | | | | • | |
| CP59 | 34 | | | | | | • | |
| CP60 | 15 | | | • | • | | • | |
| CP61 | 15 | | | • | • | | • | |
| CP62 | 15 | | | • | • | | • | |
| CP70 | 25 | | | | | | • | |

Lamp type page

| Lamp type | page | Audio visual | Micrographic | Photographic | Theatre / Stage | Disco | TV / Film / Studio | Outside Broadcast |
|-----------|------|--------------|--------------|--------------|-----------------|-------|--------------------|-------------------|
| CP77 | 21 | | | | | | | |
| CP79 | 26 | | | | | | | • |
| CP81 | 22 | | | • | | | | • |
| CP82 | 22 | | | • | | | | • |
| CP83 | 31 | | | | | | | • |
| CP86 | 15 | | | | • | • | | • |
| CP87 | 15 | | | | • | • | | • |
| CP88 | 15 | | | | • | • | | • |
| CP89 | 23 | | | | | | | • |
| CP90 | 25 | | | | | | | • |
| CP91 | 27 | | | | | | | • |
| CP92 | 27 | | | | | | | • |
| CP93 | 27 | | | | | | | • |
| CP94 | 31 | | | | | | | • |
| CP95 | 15 | | | | • | • | | • |
| CP105 | 33 | | | | | | | • |
| HX48 | 31 | | | | | | | • |
| HX270 | 31 | | | | | | | • |
| HX800 | 21 | | | • | | | | |

| Lamp type | page | Audio visual | Micrographic | Photographic | Theatre / Stage | Disco | TV / Film / Studio | Outside Broadcast |
|--|------|--------------|--------------|--------------|-----------------|-------|--------------------|-------------------|
| GX38 12K | 32 | | | | | | | |
| GX38 20K | 32 | | | | | | | |
| GX38 24K | 32 | | | | | | | |
| High Performance Lamps | | | | | | | | |
| HPL575 | 20 | | | | | | | |
| HPL575-C | 20 | | | | | | | |
| HPL575-XLL | 20 | | | | | | | |
| HPL575-XLL-C | 20 | | | | | | | |
| HPL750 | 20 | | | | | | | |
| HPL750-C | 20 | | | | | | | |
| HPL750-XLL | 20 | | | | | | | |
| Theatre TV Film & Studio lamps by ANSI code | | | | | | | | |
| BTM | 28 | | | | | | | |
| CYX | 31 | | | | | | | |
| DKX/DSF | 33 | | | | | | | |
| DKZ/DSE | 33 | | | | | | | |
| DPY | 31 | | | | | | | |

| Lamp type | page | Audio visual | Micrographic | Photographic | Theatre / Stage | Disco | TV / Film / Studio | Outside Broadcast |
|-----------|------|--------------|--------------|--------------|-----------------|-------|--------------------|-------------------|
| DTA | 34 | | | | | | | |
| DWE | 8 | | | | | | | |
| EGE | 28 | | | | | | | |
| EGJ | 29 | | | | | | | |
| EGN | 27 | | | | | | | |
| EGT | 27 | | | | | | | |
| EHD | 21 | | | | | | | |
| EHF | 21 | | | | | | | |
| EHG | 21 | | | | | | | |
| EWE | 29 | | | | | | | |
| FBE | 8 | | | | | | | |
| FBO | 8 | | | | | | | |
| FCX | 6 | | | | | | | |
| FCW | 9 | | | | | | | |
| FEL | 21 | | | | | | | |
| FEP | 21 | | | | | | | |
| FFN | 17 | | | | | | | |
| FFP | 17 | | | | | | | |
| FFR | 17 | | | | | | | |

| Lamp type | page | Audio visual | Micrographic | Photographic | Theatre / Stage | Disco | TV / Film / Studio | Outside Broadcast |
|-----------|------|--------------|--------------|--------------|-----------------|-------|--------------------|-------------------|
| FFS | 17 | | • | • | • | • | | |
| FGN | 17 | | | • | | • | | |
| FKB | 29 | | | • | | | | |
| FKD | 29 | | | • | | | | |
| FKE | 29 | | | • | | | | |
| FKF | 28 | | | • | | | | |
| FKH | 27 | | | | | • | | |
| FKJ | 27 | | | | | • | | |
| FKK | 31 | | | | | • | | |
| FKM | 29 | | | | | • | | |
| FKN | 29 | | | | | • | | |
| FKR | 21 | | | • | | | | |
| FKW | 22 | | | | | • | | |
| FLK | 21 | | | • | | | | |
| FLK/LL | 21 | | | • | | | | |
| FMR | 23 | | | • | | | | |
| FRE | 23 | | | • | | | | |
| FRG | 22 | | | | | • | | |
| FRH | 22 | | | | | • | | |

| Lamp type | page | Audio visual | Micrographic | Photographic | Theatre / Stage | Disco | TV / Film / Studio | Outside Broadcast |
|-----------|------|--------------|--------------|--------------|-----------------|-------|--------------------|-------------------|
| FRJ | 22 | | | | | • | | |
| FRK | 23 | | | | | • | | |
| FRL | 23 | | | | | • | | |
| FRM | 23 | | | | | • | | |
| FSK | 22 | | | | | • | | |
| FSL | 22 | | | | | • | | |
| FTL | 26 | | | • | | • | | |
| FTM | 26 | | | • | | • | | |
| FVA | 25 | | | | | • | | |
| FVB | 25 | | | | | • | | |
| FWP | 25 | | | • | | | | |
| FWR | 25 | | | • | | | | |
| FWS | 25 | | | • | | | | |
| FWT | 25 | | | • | | | | |
| GCS | 23 | | | • | | | | |
| GCT | 23 | | | • | | | | |
| GCV | 23 | | | • | | | | |
| GCW | 23 | | | • | | | | |
| GKV | 21 | | | • | | | | |

| Lamp type | page | Audio visual | Micrographic | Photographic | Theatre / Stage | Disco | TV / Film / Studio | Outside Broadcast |
|---|------|--------------|--------------|--------------|-----------------|-------|--------------------|-------------------|
| GKV/LL | 21 | | | • | | | | |
| Linear TV & Studio lamps by LIF code | | | | | | | | |
| P2/6 | 38 | | • | | | • | | |
| P2/7 | 42 | | • | | | • | | |
| P2/10 | 42 | | • | | | • | | |
| P2/11 | 40 | | • | | | • | | |
| P2/12 | 42 | | • | | | • | | |
| P2/13 | 38 | | • | | | • | | |
| P2/27 | 41 | | • | | | • | | |
| P2/28 | 40 | | • | | | • | | |
| Linear TV Film & Studio lamps by ANSI code | | | | | | | | |
| DXW | 39 | | | | | • | | |
| DXX | 38 | | | | | • | | |
| EHM | 40 | | | | | • | | |
| EKM | 42 | | | | | • | | |
| EJG | 40 | | | | | • | | |
| EME | 40 | | | | | • | | |

| Lamp type | page | Audio visual | Micrographic | Photographic | Theatre / Stage | Disco | TV / Film / Studio | Outside Broadcast |
|----------------------------------|------|--------------|--------------|--------------|-----------------|-------|--------------------|-------------------|
| EMF | 40 | | | | | | • | |
| FAD | 38 | | | | | | • | |
| FBY | 39 | | | | | | • | |
| FCL | 40 | | | | | | • | |
| FCM | 40 | | | | | | • | |
| FEX | 41 | | | | | | • | |
| FEY | 41 | | | | | | • | |
| Single Ended Hot restrike | | | | | | | | |
| CSR 12S/SE/HR | 64 | | | | | • | • | |
| CSR 200/SE/HR | 64 | | | | | • | • | |
| CSR 575/SE/HR | 64 | | | | | • | • | |
| CSR 1200/SE/HR | 64 | | | | | • | • | |
| CSR 2500/SE/HR | 64 | | | | | • | • | |
| CSR 4000/SE/HR | 64 | | | | | • | • | |
| CSR 6000/SE/HR | 64 | | | | | • | • | |
| CSR 12000/SE/HR | 64 | | | | | • | • | |

| Lamp type | page | Audio visual | Micrographic | Photographic | Theatre / Stage | Disco | TV / Film / Studio | Outside Broadcast |
|----------------------------------|------|--------------|--------------|--------------|-----------------|-------|--------------------|-------------------|
| Single Ended Cold Start | | | | | | | | |
| CSD 250/2 SE | 65 | | | | • | • | | |
| CSR 575/2 | 65 | | | | • | • | | |
| CSR 700/2 | 65 | | | | • | • | | |
| CSR 1200/2 | 65 | | | | • | • | | |
| Double Ended Hot restrike | | | | | | | | |
| CSR 200/DE | 65 | | | | | • | | |
| CSR 575/DE | 65 | | | | | • | | |
| CSR 1200S/DE | 65 | | | | | • | | |
| CSR 1200/DE | 65 | | | | | • | | |
| CSR 2500/DE | 65 | | | | | • | | |
| CSR 4000/DE | 65 | | | | | • | | |
| CSR 6000/DE | 65 | | | | | • | | |
| CSR 12000/DE | 65 | | | | | • | | |
| CSR 18000/DE | 65 | | | | | • | | |
| CSR 18000S/DE | 65 | | | | | • | | |

| Lamp type | page | Audio visual | Micrographic | Photographic | Theatre / Stage | Disco | TV / Film / Studio | Outside Broadcast |
|------------------------|------|--------------|--------------|--------------|-----------------|-------|--------------------|-------------------|
| CMH | | | | | | | | |
| SINGLE ENDED MINIS | 66 | | | | • | | | • |
| SINGLE ENDED | 66 | | | | • | | | • |
| PAR | 67 | | | | • | | | • |
| DOUBLE ENDED | 67 | | | | • | | | • |
| ELLIPTICAL CLEAR | 68 | | | | • | | | • |
| ELLIPTICAL DIFFUSE | 68 | | | | • | | | • |
| TUBULAR CLEAR | 68 | | | | • | | | • |
| Discharge lamps | | | | | | | | |
| CSI | | | | | | | | |
| 99-0201 | 70 | | | | | | | • |
| 99-0221 | 71 | | | | | | | • |
| 99-1222 | 71 | | | | | | | • |
| 99-1422 | 71 | | | | | | | • |
| CID | | | | | | | | |
| 99-0211 | 72 | | | | | | | • |
| 99-0222 | 73 | | | | | | | • |

| Lamp type | page | Audio visual | Micrographic | Photographic | Theatre / Stage | Disco | TV / Film / Studio | Outside Broadcast |
|--------------------------|-------|--------------|--------------|--------------|-----------------|-------|--------------------|-------------------|
| 99-0415 | 73 | | | | | | | |
| 99-0431 | 74 | | | | | | | |
| 99-1225 | 75 | | | | | | | |
| 99-1425 | 75 | | | | | | | |
| 99-1435 | 75 | | | | | | | |
| CSS | | | | | | | | |
| 150/850 | 69 | | | | | | | |
| 575/855 | 69 | | | | | | | |
| Blacklight blue | | | | | | | | |
| F20 T12/BLB | 81 | | | | | | | |
| F40 BLB | 81 | | | | | | | |
| Cinema Lamps | | | | | | | | |
| BIAX-COMPACT FLUORESCENT | 79 | | | | | | | |
| LINEAR FLUORESCENT | 79-81 | | | | | | | |

| Lamp type | page | Audio visual | Micrographic | Photographic | Theatre / Stage | Disco | TV / Film / Studio | Outside Broadcast |
|---|------|--------------|--------------|--------------|-----------------|-------|--------------------|-------------------|
| Specialist Projector lamps by LIF code | | | | | | | | |
| A1/215 | 47 | | | | | | | |
| A1/216 | 47 | | | | | | | |
| A1/220 | 47 | | | | | | | |
| A1/223 | 47 | | | | | | | |
| A1/226 | 52 | | | | | | | |
| A1/227 | 52 | | | | | | | |
| A1/229 | 53 | | | | | | | |
| A1/230 | 53 | | | | | | | |
| A1/231 | 54 | | | | | | | |
| A1/232 | 54 | | | | | | | |
| A1/233 | 47 | | | | | | | |
| A1/234 | 47 | | | | | | | |
| A1/239 | 47 | | | | | | | |
| A1/241 | 49 | | | | | | | |
| A1/244 | 48 | | | | | | | |
| A1/245 | 48 | | | | | | | |
| A1/247 | 48 | | | | | | | |
| A1/248 | 48 | | | | | | | |

Lamp type **page**

| | |
|--------|----|
| A1/249 | 48 |
| A1/252 | 54 |
| A1/258 | 60 |
| A1/259 | 54 |
| A1/261 | 47 |
| A1/262 | 47 |
| A1/264 | 47 |
| A1/266 | 55 |
| A1/268 | 49 |
| A1/270 | 47 |
| HX501 | 47 |
| HX185 | 47 |

Specialist Projector lamps by ANSI code

| | |
|---------|----|
| BRH | 47 |
| BRJ/EVB | 47 |
| BRL | 47 |
| CBA | 49 |
| DDL | 54 |

Audio visual
Micrographic
Photographic
Theatre / Stage
Disco
TV / Film / Studio
Outside Broadcast

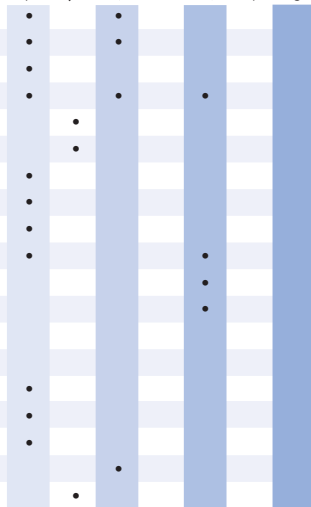

Lamp type **page**

| | |
|---------|----|
| DDM | 53 |
| DDN | 52 |
| DDS | 53 |
| DED | 54 |
| DJT | 53 |
| DNF | 55 |
| DWZ | 52 |
| DYR | 47 |
| DYS | 47 |
| DZA | 47 |
| DZE/FDS | 47 |
| EFM | 53 |
| EFN | 53 |
| EFP | 54 |
| EFR | 54 |
| EHJ | 47 |
| EJA | 55 |
| EJL | 54 |
| EJM | 54 |

Audio visual
Micrographic
Photographic
Theatre / Stage
Disco
TV / Film / Studio
Outside Broadcast

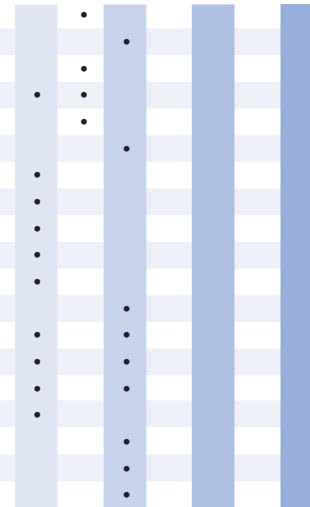

| Lamp type | page | Audio visual | Micrographic | Photographic | Theatre / Stage | Disco | TV / Film / Studio | Outside Broadcast |
|-----------|------|--------------|--------------|--------------|-----------------|-------|--------------------|-------------------|
| EJV | 55 | | | • | | | | |
| EJY | 55 | | | • | | | | |
| EKE | 54 | | | • | | | | |
| EKX | 54 | | • | | | | | |
| EKZ | 53 | | • | | | | | |
| ELB | 55 | | | • | | | | |
| ELC | 54 | • | | • | • | | | |
| ELC 500 | 54 | | | | • | | | |
| ELD/EJN | 54 | | | • | | | | |
| ELH | 54 | | | • | • | | | |
| ELS/ELR | 60 | | • | • | | | | |
| EML | 47 | • | | | | | | |
| EMM/EKS | 60 | • | | • | | | | |
| ENG | 54 | • | | • | | | | |
| ENH | 54 | | | • | • | | | |
| ENL | 57 | | | • | | | | |
| ENW/ENC | 57 | • | | • | | | | |
| ENX | 57 | • | • | | | | | |
| EPS | 49 | • | | | | | | |

| Lamp type | page | Audio visual | Micrographic | Photographic | Theatre / Stage | Disco | TV / Film / Studio | Outside Broadcast |
|-----------|------|--------------|--------------|--------------|-----------------|-------|--------------------|-------------------|
| EPT | 57 | | | • | | | | |
| EPV | 57 | | • | | | | | |
| EPW | 57 | | • | | | | | |
| EPX | 57 | | • | | | | | |
| EPZ | 57 | | • | | | | | |
| ERV | 57 | | • | | | | | |
| ESA | 50 | | | • | | | | |
| ESB | 50 | | | • | | | | |
| ESD | 57 | • | | | | | | |
| EVA | 50 | • | | | | | | |
| EVD | 47 | • | | | • | | | |
| EVV | 47 | | | • | | | | |
| EVW | 57 | | | • | | | | |
| EWF | 57 | | • | | | | | |
| EWR | 47 | | | • | | | | |
| EXL | 47 | | | • | | | | |
| EXR | 59 | • | • | • | | | | |
| EXW | 59 | • | • | • | | | | |
| EXX | 57 | • | | • | | | | |

GE Lighting World addresses

ARGENTINA

GE Iluminacion S.A.
Av. San Martin S/N Esquina 25 de Mayo
1618-El Talar
Tigre, Pcia de Buenos
Tel: (54) 11 4736 6600
Fax: (54) 11 4736 6616

AUSTRALIA

GE Lighting Australia Ltd.
125-127 Long Street
Smithfield, NSW 2164
Tel: (61) 2 9729 0011
Fax: (61) 2 9729 1144

AUSTRIA

GE Lighting Gmbh
Praunheimer Landstr. 50
60488 Frankfurt
GERMANY
Tel: (49) 69 768 010
Fax: (49) 69 768 01 430

BAHRAIN, EGYPT, JORDAN, KUWAIT, OMAN, QATAR, SAUDI ARABIA, UAE, & YEMEN

GE International Operations Co.
54 Lebanon Street, Mohandessin, Giza
EGYPT
Tel: (20) 2 301 8060 or 8065
Fax: (20) 2 303 1082

BOTSWANA, NAMIBIA, SOUTH AFRICA, ZIMBABWE

GE Lighting South Africa
5 Bridget Road
Benrose 2094
SOUTH AFRICA
Tel: (27) 11 618 3870/9
Fax: (27) 11 624 2485

BRAZIL, URUGUAY

General Electric do Brasil
Parque Industrial Thomas Edison
Rua Miguel Angelo, 37, Maria da Graca
Rio de Janeiro 20783-900
BRAZIL
Tel: (55) 21 582 6471
Fax: (55) 21 582 6533

BULGARIA

Representative Office of GE Hungary
Tungsram Lighting
15 Zar Assen, 1st floor
1680 Sofia
Tel.: (359) 2 9813492
Fax: (359) 2 9813492

CAMBODIA, LAOS, THAILAND, VIETNAM

GE Lighting (Thailand) Ltd.
191 Silom Complex Building
17th Floor, Silom Road, Bangrak
Bangkok 10500
THAILAND
Tel: (66) 2 266 2621/5
Fax: (66) 2 266 2626

CANADA

GE Lighting Canada
468 South Service Road E,
Oakville,
Ontario L6J 2X6
Tel: (1) 877 259 0941

CARIBBEAN & CENTRAL AMERICA

General Electric Company
790 N.W. 107 Avenue,
Suite 204
Miami, Florida 33172,
USA
Tel: (1) 305 551 5114
Fax: (1)305 551 5116

CHILE / BOLIVIA

General Electric de Chile S/A
Casilla 2103,
Av. Vicuna Mackenna 2385
Santiago
CHILE
Tel: (56) 2 555 3031
Fax: (56) 2 556 7329

CHINA

GE Lighting China
Nan Zheng Building
No. 580 West Nanjing Road
Shanghai, 2000041
Tel: (86) 21 5234 1111
Fax: (86) 21 52341168

Hong Kong

GE International Operations Co.Inc.
Room 801, The Lee Gardens
33 Hysan Avenue,
Causeway Bay
Hong Kong
Tel: (852) 2100 6900
Fax: (852) 2376 0013

COLOMBIA

GE Lighting, Colombia
Carrera 5 No. 81-50 Apto 204
El Pinar Alto
Santafe de Bogota
Tel: (571) 404 2203
Fax: (571) 218 4502

CROATIA

Adria Lighting
Vila Tacen d.o.o.
Exclusive agent of GE Hungary RT
Lighting Business
Tacenska 114a, 1210 Ljubljana
SLOVENIA
Tel: (386) 1 512 9245
Fax: (386) 1 530 4361

CYPRUS, GREECE, LEBANON, MALTA, SYRIA, EAST-WEST & NORTH AFRICA

GE Hungary Tungsram Lighting
1340 Budapest
Váci út 77
HUNGARY
Tel: (36) 1 399 1100
Fax: (36) 1 399 1672

CZECH REPUBLIC

GE Lighting spol. s.r.o.
Lidicka 31
658 34 Brno
Tel: (420) 5 4132 1015, (420) 5 4132 1016
Fax: (420) 5 4132 1017

DENMARK

GE Lighting A/S
Park Alle 295
DK-2605 Brøndby
Tel: (45) 43 42 44 51
Fax: (45) 43 42 44 52

ESTONIA, LATVIA, LITHUANIA

Representative Office GE Hungary
Tungsram Lighting
Elizabetes 2
LV 1340 Riga
LATVIA
Tel: (371) 7 321 710
Fax: (371) 7 321 762

FINLAND

GE Lighting Oy
Malmin kauppatie 18, 5 krs.
FIN-00700 Helsinki
Tel: (358) 9 8560 6780
Fax: (358) 9 8560 6790

FRANCE & BENELUX

GE Lighting SARL
ZAC Paris Nord II
13, rue de la Perdrix
B.P. 50073
95947 Roissy CDG Cedex
FRANCE
Tel: (33) 1 48 63 68 00
Fax: (33) 1 48 63 68 08

GERMANY

GE Lighting Gmbh
Praunheimer Landstr. 50
60488 Frankfurt
Tel: (49) 69 768 010
Fax: (49) 69 768 01 430

HUNGARY

GE Hungary Tungsram Lighting
1340 Budapest
Váci út 77
Tel: (36) 1 399 1100
Fax: (36) 1 399 1672

INDIA

GE Lighting Ltd.
H.R. Complex , 310/6 Industrial
Main Road
Koramangala 5th Block
Bangalore 560 095
Tel: (91) 80 552 2023
Fax: (91) 80 552 2021

INDONESIA

PT. GE Lighting Indonesia
BRI II Tower, Fl. 27th
Jalan Jenderal Sudirman Kav. 44-46
Jakarta 10210
Tel: (62) 21 573 0491
Fax: (62) 21 574 5241

IRELAND

GE Lighting Ltd.
280 Holly Road
Western Industrial Estate
Naas Road
Dublin 12
Tel: (353) 1 456 5591
Fax: (353) 1 450 4142

ITALY

GE Lighting Srl
Via Astichello 2,
36010 Vicenza
Tel: (39) 0444 391 311
Fax: (39) 0444 391 443

ISRAEL

GE Hungary Tungsram Lighting
1340 Budapest,
Váci út 77
Tel: (36) 1 399 1100
Fax: (36) 1 399 1672

JAPAN

GE Consumer Products Japan Ltd.
2nd Fl., Kowa 16 Building, South Wing,
9-20, Akasaka 1-chome
Minato-ku, Tokyo 107-0052
Tel.: (81) 3 6229 1460
Fax: (81) 3 3224 1560

KAZAKHSTAN

GE Lighting Rep. Office
Prime Business Centre
100. G.ul.Furmanova, 2nd Floor
480091 Almaty
Tel: (7) 3272 509 833, (7) 3272 509 834
Fax: (7) 3272 507 851

KOREA

GE Samsung Lighting Co.Ltd.
3rd Floor Shinjungang B/D 646-9
Yoksam-Dong, Kangnam-Gu
Seoul, Korea 135-911
Tel: (82) 2 569-4181
Fax: (82) 2 563-9933

MACEDONIA, SERBIA, MONTENEGRO & BiH

VSD MERKUR dooel Exclusive Agent of
GE Hungary Rt.
Kozle 88 B-3/7
1000 Skopje
MACEDONIA
Tel: (389) 2 391129
Fax: (389) 2 3917530

MALAYSIA

General Electric International, Inc.
Suit 3B-8-3 Block 3B
Level 8, Plaza Sentral
Jalan Stesen Sentral 5,
Kuala Lumpur Sentral 50470
Kuala Lumpur.
Tel : (603) 2273-9788
Fax : (603) 2273-3473

MEXICO

GE Lighting Mexico, SA de CV
Av. Churubusco No 3900 Norte
Apartado Postal 216
64510 Monterrey, N.L. Mexico
Tel: (52) 8 318 5600
Fax: (52) 8 318 5693

NEW ZEALAND

GE Lighting New Zealand
Level 10, Lumley House
7 City Road
Auckland
Tel: (64) 9 353 6706
Fax: (64) 9 353 6707

NORWAY

GE Lighting AS
Karenslyst Allé 2,
0214 Oslo
Tel: (47) 23 28 21 00
Fax: (47) 23 28 21 09

PERU & ECUADOR

GE Lighting Peru
Av. Garcilaso de la Vega 1420
Esquina Con Av. Espana,
Lima
PERU
Tel: (511) 433 9862
Fax: (511) 332 0482

PHILIPPINES

GE Lighting Philippines
1873 P. Domingo Street
1207 Makati City, Metro Manila
POB 2087 MCC
Tel: (632) 895 7051
Fax: (632) 890 8186

POLAND

General Electric Co. Polska Sp.z.o.o.
Ul. Jagiellonska 74,
03-301 Warsaw
Tel: (48) 22 675 4466
Fax: (48) 22 814 1629

PORTUGAL

GE Lighting Appliances España, s.a.
Llull 95 – 97 Planta Baja
08005 Barcelona
SPAIN
Freephone in Portugal: 800 836 010
Free fax in Portugal: 800 836 007

ROMANIA

GE Romania SRL
Besta Center
Str. Constantin Apostol nr. 10, etaj 4,
Sector 6, Bucuresti
Tel: (40) 1 413 3328, 2247
Fax: (40) 1 413 5386

RUSSIA

Representative Office of GE Hungary
Tungsram Lighting
Kosmodamianskaya nab.52
Building 1, 6th Floor
Moscow 115054
Tel: (7) 095 935 7211
Fax: (7) 095 935 7279

SINGAPORE, BRUNEI

GE Pacific Pte. Ltd.
240, Tanjong Pagar Rd.
GE Tower #06-00, Singapore 088540
SINGAPORE
Tel: (65) 6326 3393
Fax: (65) 6326 3015

SLOVAKIA

GE Lighting Tungsram RT Representative
Office
Cyrilometódska 38
94069 Nové Zámky
Tel: (421) 35 642 3075
Fax: (421) 35 642 3075

SLOVENIA

ADRIA LIGHTING
Vila Tacen d.o.o. Exclusive agent of GE
Hungary RT Lighting Business
Tacenska 114a
1210 Ljubljana
Tel: (386) 1 512 9245
Fax: (386) 1 530 4361

SPAIN

GE Lighting Appliances España, s.a.
Llull 95 – 97 Planta Baja
08005 Barcelona
Freephone in Spain: 900 993 612
Free fax in Spain: 900 993 609

SWEDEN

GE Lighting AB
Box 306, Solna strandväg 98
171 75 Stockholm
Tel: (46) 8 51 99 22 12
Fax: (46) 8 51 99 22 14

SWITZERLAND

GE Lighting GmbH
Praunheimer Landstr. 50
60488 Frankfurt
GERMANY
Tel: (49) 69 768 010
Fax: (49) 69 768 01 430

TAIWAN

GE Lighting Taiwan
2Fl., No. 170,
Min Chuan E. Road, Sec. 3,
Taipei, Taiwan, R.O.C.
Tel: (886) 2 2719 6000
Fax: (886) 2 2547 4568

TURKEY

General Elektrik T.A.S.
Keskin Kalem Sk. No:5
80280 Esentepe/Istanbul
Tel: (90) 212 337 45 00
Fax: (90) 212 337 45 55

UKRAINE

General Electric Co.
Horizont Tower
42/44 Shovkovichna str., 8 Floor
Kiev 01004
Tel: (380) 44 490 69 83
Fax: (380) 44 490 69 82

UNITED KINGDOM

GE Lighting Ltd.
Lincoln Road, Enfield
Middlesex,
EN1 1SB
Tel (44) 208 366 1166
Fax (44) 208 727 4400

UNITED STATES OF AMERICA

GE Lighting
Nela Park, 1975 Noble Road
Cleveland, Ohio 44112
Tel: (1) 216 266 2121
Fax: (1) 216 266 2780

VENEZUELA

GE Iluminacion de Venezuela S.A.
TERMAQ
Centro Banaven (Cubo Negro)
Torre A Piso 6
Avenida La Estancia, Chuao
Caracas,
Tel: (58) 212 902 5131
Fax: (58) 212 902 5158

VIETNAM

GE International, Inc.
Suite 701, Central Building,
31 Hai Ba Trung Str
Hanoi
Tel. 844 8251016
Fax. 844 8250551

YUGOSLAVIA

VSD MERKUR dooel Exclusive Agent of
GE Hungary Rt.
Oton Zupancic 32b/9,
11000 Belgrade
Tel: (381) 11 3193741
Fax: (381) 11 3193741

Web site

www.GELighting.com