

GE Monogram®

Owner's Manual

Stainless Steel

Professional

30" Range

*Exclusive  
40-point  
inspection*

Please call for your exclusive 40-Point Inspection! In the U.S.A.: 800.444.1845.  
In Canada, please call 1.888.880.3030.

Owners of Monogram professional ranges enjoy the additional benefit of a complimentary visit by a specially trained technician. This includes temperature calibration of each oven and cooktop element. This is Monogram’s way of ensuring correct installation and precise operation of your new professional range.

Our Preferred Service Specialists are always at your service. If any Monogram appliance should ever require service, please call the Monogram Preferred Service number shown above. Call anytime—24 hours a day, 7 days a week. The Monogram Preferred Service Specialist will promptly coordinate a service appointment.

*Contents*

**Care and Cleaning**

Broiler Pan and Grid ..... 22

Burner Assembly ..... 23

Control Panel and Knobs ..... 21

Drip Tray ..... 21

Oven Heating Elements ..... 21

Oven Light ..... 22

Shelves ..... 21

Stainless Steel ..... 22

**Consumer Services**

Important Phone Numbers ..... 25

Model and Serial Number ..... 3, 28

Problem Solver ..... 24

Product Registration ..... 3, 27, 28

Safety Instructions ..... 2, 4–8

Warranty ..... 26

**Oven**

Aluminum Foil ..... 6, 14, 17

Baking/Roasting ..... 13–15

Broiling/Broiling Guide ..... 17, 18

Controls ..... 9, 13, 16, 17, 20

Convection Cooking ..... 15, 16

Features ..... 9

Self-Cleaning Instructions ..... 19, 20

**Surface Cooking**

Burners ..... 10–11

Controls ..... 9, 10

Cookware ..... 12

Features ..... 9

Electronic Ignitors ..... 11

Simmering ..... 11



**WARNING: If the information in this manual is not followed exactly, a fire or explosion may result causing property damage, personal injury or death.**

- Do not store or use gasoline or other flammable vapors and liquids in the vicinity of this or any other appliance.
- **WHAT TO DO IF YOU SMELL GAS**
  - Do not try to light any appliance.
  - Do not touch any electrical switch; do not use any phone in your building.
  - Immediately call your gas supplier from a neighbor’s phone. Follow the gas supplier’s instructions.
  - If you cannot reach your gas supplier, call the fire department.
- Installation and service must be performed by a qualified installer, service agency or the gas supplier.



**⚠ WARNING**

- ALL RANGES CAN TIP
- INJURY COULD RESULT
- INSTALL ANTI-TIP BRACKET PACKED INSIDE OVEN
- SEE INSTRUCTIONS

---

*Before  
using  
your  
range*

Read this manual carefully. It is intended to help you operate and maintain your new range properly.  
Keep it handy for answers to your questions.

If you don't understand something or need more help, there is a list of toll-free consumer service numbers included in the back section of this manual.

OR

Visit our Website at: [www.monogram.com](http://www.monogram.com)

---

*Write  
down the  
model &  
serial  
numbers*

You'll find them on a label in the rear of the burner box below the burner grates.

These numbers are also on the Consumer Product Ownership Registration Card included in this manual.

**Before sending in this card, please write these numbers here:**

\_\_\_\_\_

Model Number

\_\_\_\_\_

Serial Number

Use these numbers in any correspondence or service calls concerning your range.

---

*If you  
received a  
damaged  
range*

Immediately contact the dealer (or builder) that sold you the range.

---

*Save time  
& money*

Before you request service, check the Problem Solver in the back of this manual.

It lists causes of minor operating problems that you can correct yourself.

---

*If you  
need  
service*

To obtain service, see the Consumer Services page in the back of this manual.

We're proud of our service and want you to be pleased. If for some reason you are not happy with the service you receive, here are the steps to follow for further help.

FIRST, contact the people who serviced your appliance. Explain why you are not pleased. In most cases, this will solve the problem.

NEXT, if you are still not pleased, write all the details—including your phone number—to:

Manager, Customer Relations  
GE Appliances  
Appliance Park  
Louisville, KY 40225

# IMPORTANT SAFETY INSTRUCTIONS

---

## IMPORTANT SAFETY NOTICE

- **The California Safe Drinking Water and Toxic Enforcement Act** requires the Governor of California to publish a list of substances known to the state to cause cancer, birth defects or other reproductive harm, and requires businesses to warn customers of potential exposure to such substances.
- **The fiberglass insulation in self-clean ovens gives off a very small amount of carbon monoxide during the cleaning cycle.** Exposure can be minimized by venting with an open window or using a ventilation fan or hood.
- **Gas appliances can cause minor exposure to four of these substances**, namely benzene, carbon monoxide, formaldehyde and soot, caused primarily by the incomplete combustion of natural gas or LP fuels.  
  
Properly adjusted burners, indicated by a bluish rather than a yellow flame, will minimize incomplete combustion. Exposure to these substances can be minimized further by venting with an open window or using a ventilation fan or hood.

---

## SAFETY PRECAUTIONS

When using your appliance, follow basic safety precautions, including the following:

- **Have the installer show you the location of the range gas cut-off valve and how to shut it off if necessary.**
- **Be sure all packing materials are removed from the range** before operating it to prevent fire or smoke damage should the packing material ignite.
- **After prolonged use of a range, high floor temperatures may result and many floor coverings will not withstand this kind of use.** Never install the range over vinyl tile or linoleum that cannot withstand such use. Never install it directly over interior kitchen carpeting.
- **Be sure your range is correctly adjusted by a qualified service technician or installer for the type of gas (natural or LP) that is to be used.**

**WARNING:** These adjustments must be made by a qualified service technician in accordance with the manufacturer's instructions and all codes and requirements of the authority having jurisdiction. Failure to follow these instructions could result in serious injury or property damage. The qualified agency performing this work assumes responsibility for the conversion.

### **▲ WARNING—**

All ranges can tip and injury could result. To prevent accidental tipping of the range, attach it to the wall by installing the Anti-Tip device supplied.



To check if the device is installed and engaged properly, carefully tip the range forward. The Anti-Tip device should engage and prevent the range from tipping over.



If you pull the range out from the wall for any reason, make sure the device is properly engaged when you push the range back against the wall.

If it is not, there is a possible risk of the range tipping over and causing injury if you or a child stand, sit or lean on an open door.

Please refer to the Anti-Tip information in the installation instructions.

Failure to take this precaution could result in tipping of the range and injury.

- **Locate the range out of kitchen traffic path and out of drafty locations and areas with poor air circulation.**

---

## SAFETY PRECAUTIONS

- **Use this appliance only for its intended use** as described in this manual.
- **Be sure your appliance is properly installed and grounded** by a qualified technician in accordance with the provided installation instructions.
- **Do not attempt to repair or replace any part of your range unless it is specifically recommended in this manual.** All other servicing should be referred to a qualified technician.
- **Before performing any service, DISCONNECT THE RANGE POWER SUPPLY AT THE HOUSEHOLD DISTRIBUTION PANEL BY REMOVING THE FUSE OR SWITCHING OFF THE CIRCUIT BREAKER.**
- **Do not leave children alone**—children should not be left alone or unattended in an area where an appliance is in use. They should never be allowed to sit or stand on any part of the appliance.
- **Do not allow anyone to climb, stand or hang on the door, kick panel, drip tray handle, or cooktop.** They could damage the range and even tip it over, causing severe personal injury.
- **Do not store flammable materials in the oven or near the cooktop.**
- **CAUTION: ITEMS OF INTEREST TO CHILDREN SHOULD NOT BE STORED IN CABINETS ABOVE A RANGE OR ON THE BACKSPASH OF A RANGE—CHILDREN CLIMBING ON THE RANGE TO REACH ITEMS COULD BE SERIOUSLY INJURED.**
- **For your safety, never use your appliance for warming or heating the room.**
- **Never wear loose-fitting or hanging garments while using the appliance.** Be careful when reaching for items stored over the range. Flammable material could be ignited if brought in contact with surface burners, burner grates or oven heating elements and may cause severe burns.
- **Use only dry pot holders**—moist or damp pot holders on hot surfaces may result in burns from steam. Do not let pot holders touch surface burners, burner grates or oven heating elements. Do not use a towel or other bulky cloth.
- **When surface cooking, do not touch the surface burners, burner grates or the surrounding areas.**  
**When using the oven, do not touch the oven heating elements,** the interior surface of the oven or the exterior area immediately surrounding the door or back trim.  
These surfaces may be hot enough to burn.  
During and after use, do not touch, or let clothing or other flammable materials contact, the surface burners, areas near the surface burners, or any interior area of the oven; allow sufficient time for cooling first.  
Potentially hot surfaces include the cooktop, areas facing the cooktop, oven vent opening, surfaces near the opening, crevices around the oven door, the drip tray handle directly above the oven door and metal trim parts above the door.  
The drip tray gets hot when the oven is on. Do not remove the drip tray until it is cool.  
**CAUTION:** The inside surface of the oven may be hot when the door is opened.
- **Do not store plastic, flammable liquids or combustible materials on top of the optional high shelf.**
- **Keep the ventilator hood and grease filters clean to maintain good venting and to avoid grease fires.** Turn the ventilator OFF in case of fire or when intentionally “flaming” liquor or other spirits on the cooktop. The blower, if in operation, could spread the flames.
- **DO NOT obstruct the flow of combustion or ventilation air to the appliance.** Be sure a fresh air supply is available.

# IMPORTANT SAFETY INSTRUCTIONS

---

## SAFETY PRECAUTIONS

- **Do not use water on grease fires. Never pick up a flaming pan.** Turn the controls off. Smother a flaming pan on a surface unit by covering the pan completely with a well-fitting lid, cookie sheet or flat tray. Use a multi-purpose dry chemical or foam-type fire extinguisher.

Flaming grease outside a pan can be put out by covering it with baking soda or, if available, by using a multi-purpose dry chemical or foam-type fire extinguisher.

Flame in the oven can be smothered completely by closing the oven door and turning the oven off or by using a multi-purpose dry chemical or foam-type fire extinguisher.

- **DO NOT STORE OR USE COMBUSTIBLE MATERIALS, GASOLINE OR OTHER FLAMMABLE VAPORS AND LIQUIDS IN THE VICINITY OF THIS OR ANY OTHER APPLIANCE.**
- **Do not let cooking grease or other flammable materials accumulate in or near the range. Clean the drip tray after every use.**
- **If you smell gas**, the installer has not done a proper job of checking for leaks. You can have a small leak and therefore a faint gas smell if the connections are not completely tight.

Finding a gas leak is **NOT** a do-it-yourself procedure. Some leaks can only be found with the burner control in the ON position and for your protection it must be done by a qualified service technician. Never use an open flame to locate a leak.

- **If by some chance a burner goes out and gas escapes, open a window or a door to let the room air out.** Do not attempt to use the appliance until the gas has had time to dissipate. Follow the instructions in What to do if You Smell Gas.
- **Do not use aluminum foil to line any part of the oven or cooktop.** Using a foil liner could result in a fire hazard or the obstruction of the flow of combustion and ventilation air. Foil is an excellent heat insulator and heat will be trapped underneath it. This trapped heat can upset the cooking performance and can damage the finish of the oven or the cooktop.
- **Cook meat and poultry thoroughly—meat to at least an INTERNAL temperature of 160°F. and poultry to at least an INTERNAL temperature of 180°F.** Cooking to these temperatures usually protects against foodborne illness.

---

## SURFACE COOKING

- **Do not heat unopened food containers;** a build-up of pressure may cause the container to burst.
- **Set the burner control so that the flame heats only the bottom of the pan** and does not extend beyond the bottom of the pan. Excessive flame is hazardous. The high BTU burners can easily melt cookware handles.
- **Hold the handle of the pan, using a dry pot holder,** to prevent movement of the utensil when stirring or turning food.
- **Always heat fat slowly, and watch as it heats.**
- **Always use the LITE position when igniting the surface burners** and make sure the burners have ignited, including the center simmer flame.
- **Do not let pot holders come near open flames when lifting cookware.** Do not use a towel or other bulky cloth in place of a pot holder.
- **Never leave the surface burners unattended at high flame settings.** Boilovers cause smoking and greasy spillovers that may catch on fire. If the burner flames are smothered by a severe boilover which affects the ignitor, unburned gas will escape into the room.

---

## SURFACE COOKING

- **To minimize the possibility of burns**, ignition of flammable materials and spillage, turn cookware handles toward the side or back of the range without extending over adjacent burners.
- **Never block the vents (air openings) of the range.** They provide the air inlet and outlet that are necessary for the range to operate properly with correct combustion. Air openings are located at the top and bottom of the oven door, drip tray, drip tray handle area, vent area, and area immediately surrounding the top burners (burner pans).
- **Always turn the surface burners to OFF before removing cookware.**
- **Carefully watch foods being fried at a high flame setting.**
- **Foods for frying should be as dry as possible.** Frost on frozen foods or moisture on fresh foods can cause hot fat to bubble up and over the sides of the pan.
- **Use the least possible amount of fat for effective shallow or deep fat frying.** Filling the pan too full of fat can cause spillovers when food is added.
- **Use a deep fat thermometer** whenever possible to prevent overheating fat beyond the smoking point.
- **Never try to move a pan of hot fat**, especially a deep fat fryer. Wait until the fat is cool.
- **When using glass cookware**, make sure it is designed for top-of-range cooking.
- **If a combination of oils or fats will be used in frying**, stir together before heating or as fats melt slowly.
- **Use proper pan size**—avoid pans that are unstable or easily tipped. Select cookware having flat bottoms large enough to properly contain food and avoid boilovers and spillovers and large enough to cover burner grate. This will both save cleaning time and prevent hazardous accumulations of food, since heavy spattering or spillovers left on the range can ignite. Use pans with handles that can be easily grasped and remain cool.
- **Do not leave any items on the cooktop.** The hot air from the vent may ignite flammable items and will increase pressure in closed containers, which may cause them to burst.
- **Keep all plastics away from the top burners.**
- **Do not leave plastic items on the cooktop**—they may melt if left too close to the vent.
- **To avoid the possibility of a burn**, always be certain that the controls for all burners are at the OFF position and all grates are cool before attempting to remove them.
- **When preparing flaming foods under the vent hood, turn the fan on.**
- **Grease is flammable.** Let hot grease cool before attempting to handle it. Avoid letting grease deposits collect in the container under the cooktop burners. Clean these areas after each use or boilover.
- **For proper lighting and performance of the cooktop burners, keep the burner ports clean.** It may be necessary to clean these when there is a boilover or when the burner does not light, even though the electronic ignitors click.
- **After cleaning, it is important to make sure the outer cap/burner port is properly aligned with the burner base.** Incorrect alignment will produce poor burner performance. Never operate the burner without all burner parts in place.
- **Clean the cooktop with caution.** Avoid steam burns; do not use a wet sponge or cloth to clean the cooktop while it is hot. Some cleaners produce noxious fumes if applied to a hot surface. Follow manufacturer's directions.
- **If range is located near a window**, do not hang long curtains that could blow over the surface burners and create a fire hazard.
- **Be sure all the range and/or cooktop controls are turned off and the appliance is cool** before using any type of aerosol cleaner or cooking spray on or around the appliance. The chemical that produces the spraying action could, in the presence of heat, ignite or cause metal parts to corrode.

# IMPORTANT SAFETY INSTRUCTIONS

---

## OVEN

- **Stand away from the range when opening the oven door.** Hot air or steam which escapes can cause burns to hands, face and/or eyes.
- **Never “open door broil” with children nearby.** They could quickly come into contact with a hot oven interior surface, causing severe burns.
- **Children in walkers, or children crawling, can be attracted to the round oven door handle and may grab and open the oven door.** This can result in injury from the door being pulled open on a child, or severe burns if the oven is in use and hot.
- **Do not heat unopened food containers.** Pressure could build up and the container could burst, causing an injury.
- **Keep the oven vent unobstructed.**
- **Keep the oven free from grease buildup.**
- **Place the oven shelf in the desired position while the oven is cool.** If shelves must be handled when hot, do not let pot holder contact the heating elements.
- **Pulling out the shelf to the shelf stop is a convenience in lifting heavy foods.** It is also a precaution against burns from touching hot surfaces of the door or oven walls.
- **When using cooking or roasting bags in the oven,** follow the manufacturer’s directions.
- **Do not use your oven to dry newspapers.** If overheated, they can catch on fire.
- **Do not use oven for a storage area.** Items stored in an oven can ignite.
- **Do not leave paper products, cooking utensils or food in the oven when not in use.**

---

## SELF-CLEANING OVEN

- **Do not clean the door gasket.** The door gasket is essential for a good seal. Care should be taken not to rub, damage or move the gasket.
- **Do not use oven cleaners.** No commercial oven cleaner or oven liner protective coating of any kind should be used in or around any part of the oven. Residue from oven cleaners will damage the inside of the oven when the self-clean cycle is used.
- **Clean only parts listed in this Owner’s Manual.**
- **Before self-cleaning the oven,** remove the oven shelves, **oven shelf slide assemblies,** broiler pan, grid and other cookware.
- **Be sure to wipe up excess spillage before starting the self-cleaning operation.**
- **If the self-cleaning mode malfunctions,** turn the oven off and disconnect the power supply. Have it serviced by a qualified technician.

SAVE THESE INSTRUCTIONS



# Features of Your Range

Stainless Steel Range

## Design information

(Not all features are on all models. Appearance may vary.)

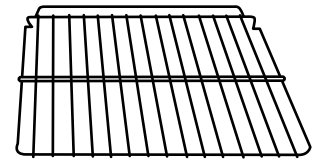
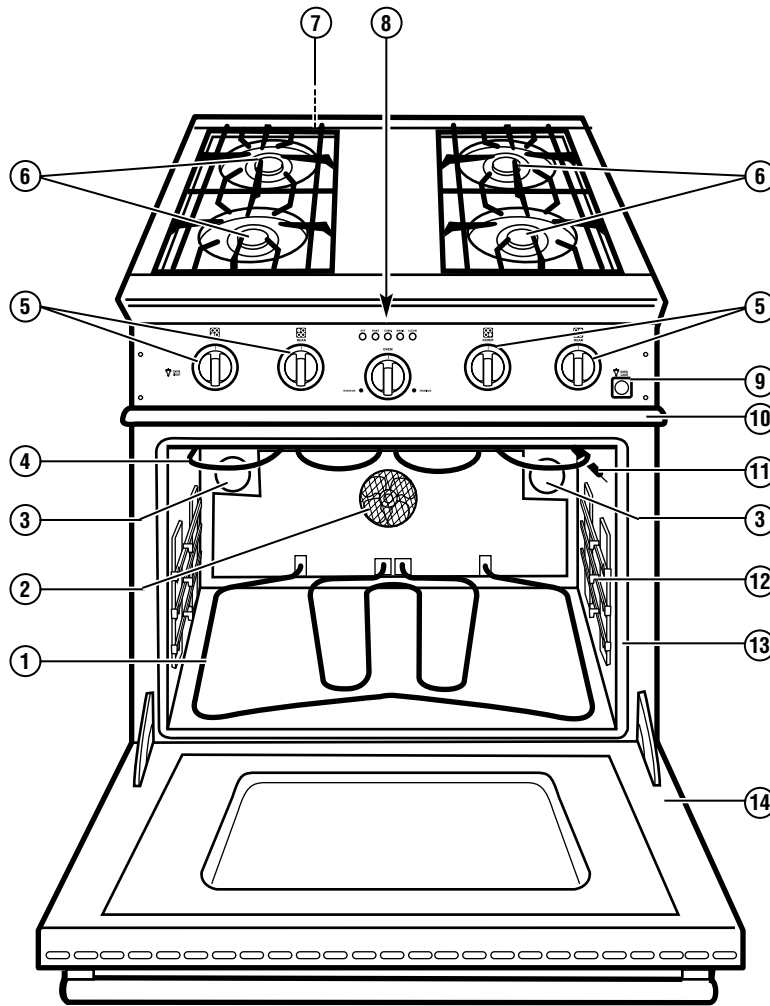

Oven shelf

ZDP30L4G  
ZDP30N4G

Feature Index	Page
1 Bake Element	21
2 Convection Fan	15
3 Oven Lights	22
4 Broil Element	21
5 Cooktop Burner Control Knobs	10, 21
6 Burner Assemblies	10, 23
7 Model and Serial Numbers (in rear of burner box below grates—can be seen when grates are removed)	3, 28
8 Oven Controls	13, 16, 17, 20, 21
9 Oven Light Switch	—
10 Drip Tray	5, 6, 21
11 Thermostat Bulb	—
12 Oven Shelf Slide Assemblies	19
13 Oven Door Gasket	8
14 Oven Door	17

### Control knobs

The control knobs are in front of the burner they control. The oven controls are placed slightly lower than the surface burner control knobs.

The surface burners have an infinite number of heat settings as there are no fixed positions between HI and LO.

To turn ON a surface burner, push the control in, then turn it counterclockwise to the LITE position.

Check to be sure the burner you turned on is the one you want to use.

You will hear the ignitor click. When the gas is ignited all around the burner and into the central simmer burner below the simmer cap, turn the knob back to the desired setting.

When using the simmer burner, always ensure that it lights from the main burner.

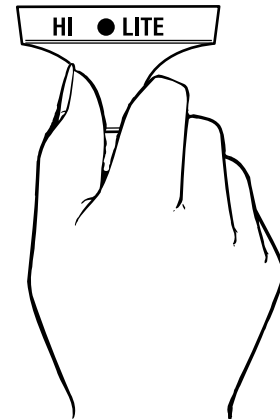

Push the control in and turn it counterclockwise to the LITE position.

### Burners

Your new professional gas range is equipped with burners typical of those used in restaurants. These burners are designed in two pieces for easy cleaning and control.

The center, smaller cap covers and protects the simmer burner from boilovers that could put the flame out. This cap also spreads the simmer burner heat out to avoid too much heat being concentrated on the center of the pan.

The simmer burner is always on when the burner is in use. The burner should never be operated if the simmer cap is not in place.

The outer cap /port ring constitute the main burner and are in operation between the HI and LO settings.

The burners have electronic spark ignition to eliminate continuously burning pilots. When the outer cap/port ring is on and the flame is blown out, it will relight. The burners are rated at 15,000 BTU around the outer cap/port ring. When turned to the simmer setting, only the center of the burner is lit, and it is rated at 500 BTU.

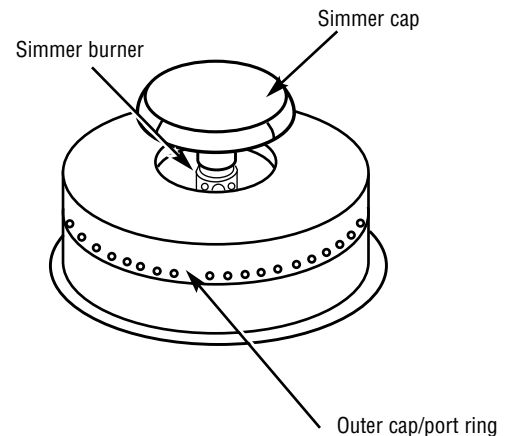

---

## *Electronic ignitors*

**NOTE:** Keep the ignitor, ignitor cap and burner ports clean.

If a burner does not ignite, listen for the clicking sound. If the ignitor is not clicking, turn off the burner. Check the circuit breaker for a blown fuse or a tripped circuit breaker. If the ignitor still fails to operate, check the Problem Solver in the back of this manual or the Power Failure information in this section.

**NOTE:** If you are using propane gas, a slight pop or flash may occur at the burner ports a few seconds after the burner has been turned off. This “extinction pop” is normal for propane gas.

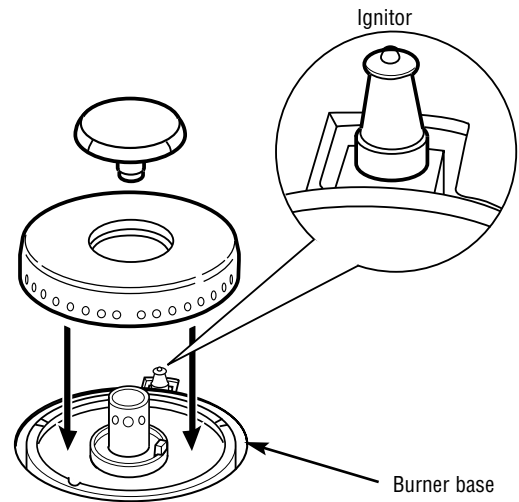

---

## *Simmering*

Your new professional gas range has exceptionally low simmering capabilities. The center simmer cap serves as a heat diffuser to spread out the heat to avoid having a center hot spot. Keep in mind that because of the high heat capacity of the outer burner, and the mass of the cast iron burner grates (they retain heat longer than lighter, conventional grates), some foods may continue to cook by retained heat after the burner has been turned off.

The simmer burner is lit from the outside burner flame.

The flame travels through the simmer ignition channels and crosses over onto the simmer burner located just beneath the simmer cap. When lighting only the simmer burner, always light the main burner first. This will in turn provide the ignition source for the simmer burner. Ensure that the simmer ports are lit before turning the control knob down to the simmer position. Should a strong draft or boilover extinguish the simmer flame, it will not relight automatically as the outer burner would.

---

## *Burner efficiency and flame characteristics*

The burner flame should burn completely around and within the burner with no excessive noise or lifting. The flame should be blue in color and stable with no yellow tips.

An improper air-gas mixture may cause either a burner flutter or a yellow-tipped flame. A technician should adjust the flame.

During initial use, foreign particles in the gas line, or dust in the air or around the appliance may cause an orange flame. This will disappear with use.

---

## *Power failure*

The electric ignition that lights the surface burners will not operate during a power failure.

To light the surface burners during a power failure, turn the control knob for the burner you want to light to LITE while holding a lighted match to the outer ring.

After the flame is burning all the way around the burner, adjust the flame.

It is necessary to light each burner separately each time you want to use it during a power failure.

### Flame height

The correct height of the flame mainly depends on the size of the bottom of the cooking utensil, the material of the cooking utensil, the amount and type of food and the amount of liquid in the utensil.

For safe handling of cookware, never let the flame extend up the sides of the cookware. Any flame larger than the bottom of the cookware is wasted heat and only serves to heat the handle.

Watch the flame, not the knob, as you reduce heat.

- For safety reasons the flame must never extend beyond the bottom of the cooking utensil. Never allow flames to curl up the side of the pan.
- Be very careful if the pans have plastic handles, as these large professional-size burners can flame up on the outside of the pan and melt or bubble the handles.
- Utensils which conduct heat slowly (such as glass-ceramic) should be used with medium to low flames. If you are cooking with a large amount of liquid, a slightly larger flame can be used.

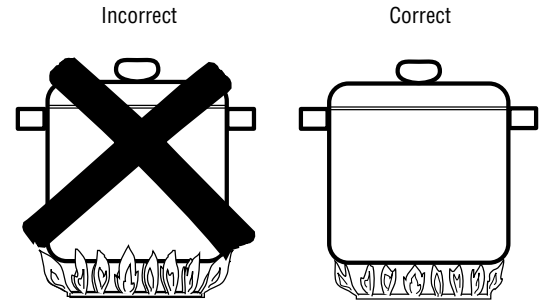

**Note:** The flame size on a gas burner should match the cookware you are using.

### Cookware

**Do not operate a burner for an extended period of time without cookware on the grate. The finish on the grate may chip without cookware to absorb the heat.**

**Aluminum:** Medium-weight cookware is recommended because it heats quickly and evenly. Most foods brown evenly in an aluminum skillet. Use saucepans with tight-fitting lids for cooking with minimum amounts of water.

**Cast Iron:** If heated slowly, most skillets will give satisfactory results.

**Enamelware:** Under some conditions, the enamel of some cookware may melt. Follow cookware manufacturer's recommendations for cooking methods.

**Glass:** There are two types of glass cookware—those for oven use only and those for surface cooking (saucepans, coffee and teapots). Glass conducts heat very slowly.

**Heatproof Glass-Ceramic:** Can be used for either surface or oven cooking. It conducts heat very slowly and cools very slowly. Check cookware manufacturer's directions to be sure it can be used on gas cooktops.

**Stainless Steel:** This metal alone has poor heating properties, and is usually combined with copper, aluminum or other metals for improved heat distribution. Combination metal skillets generally work satisfactorily if they are used at medium heat as the manufacturer recommends.

**Wok:** A large, professional-sized wok and wok ring, specially designed for use on this range, is available from your dealer. Ask for model ZXWK22Y.

### Oven shelves

**To avoid possible burns**, place the shelves in the correct position before you turn the oven on.

The correct shelf position depends on the kind of food and the browning desired.

The shelves have stop-locks, so that when placed correctly on the supports, they will stop before coming completely out, and will not tilt. When placing and removing cookware, pull the shelf out to the bump on the shelf support.

**To remove a shelf**, pull it toward you, tilt the front end up and pull it out.

**To replace**, place the end of the shelf (stop-locks) on the support, tilt up the front and push the shelf in.

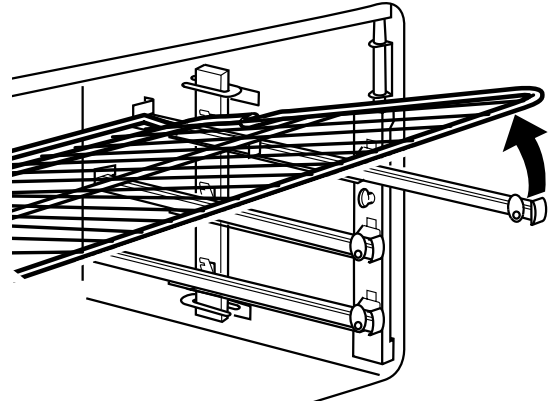

The oven has 3 shelf positions.

### How to set the oven for baking or roasting

**1** Push in the BAKE selector button.

**2** Using the thermostat dial, set the desired temperature.

- The OVEN ON light turns on and remains on until the OFF selector button has been pushed.
- The HEATING light turns on. Once the HEATING light initially cycles off, the oven is preheated.

**3** Check the food for doneness at the minimum time on the recipe. Cook longer if necessary.

**4** Push in the OFF selector button when baking is finished.

**NOTE:** When roasting, check the weight of the meat. Place the meat fat side up, or for poultry, breast side up, on the roasting grid in a shallow pan. The melting fat will baste the meat. Select a pan as close to the size of the meat as possible. (The broiler pan with grid is a good pan for this.)

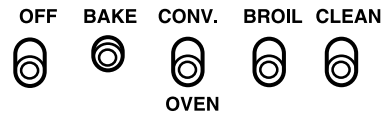

Thermostat dial

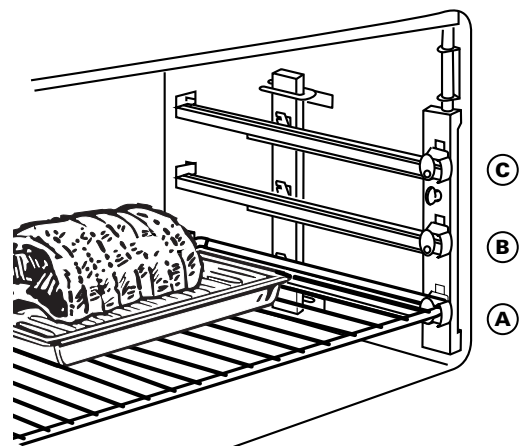

When roasting, use the A or B shelf position.

## Using the Oven

### *Stainless Steel Range*

---

#### *Baking pans/sheets*

Use the proper baking pan. The type of finish on the pan determines the amount of browning that will occur.

- Dark, rough or dull pans absorb heat resulting in a browner, crisper crust. Use this type for pies.

- Shiny, bright and smooth pans reflect heat, resulting in a lighter, more delicate browning. Cakes and cookies require this type of pan or sheet.

- Glass baking dishes also absorb heat. When baking in glass baking dishes, the temperature may need to be reduced by 25°F.

#### *Pan placement*

For even cooking and proper browning, there must be enough room for air circulation in the oven. Baking results will be better if baking pans are centered as much as possible rather than being placed to the front or to the back of the oven.

Pans should not touch each other or the walls of the oven. Allow 1- to 1½-inch space between pans as well as from the back of the oven, the door and the sides.

If you need to use two shelves, stagger the pans so one is not directly above the other. Check food on both shelves at the minimum time. Sometimes one shelf may cook slightly faster than the other, depending on the food.

#### *Preheating*

Preheat the oven if the recipe calls for it. To preheat, set the oven at the correct temperature—selecting a higher temperature does not shorten preheat time.

Preheat for about 15 minutes. Preheating is necessary for good results when baking cakes, cookies, pastry and breads.

#### *Aluminum foil*

Never entirely cover a shelf with aluminum foil. This will disturb the heat circulation and result in poor baking. A smaller sheet of foil may be used to catch a spillover by placing it on a lower shelf several inches below the food.

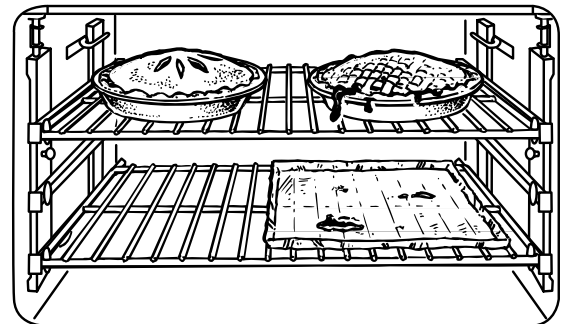

---

*What is convection cooking?*

**In a convection oven,** a fan circulates the heated air evenly, over and around the food. This circulating hot air is evenly distributed throughout the oven cavity. As a result, foods are evenly cooked and browned—often in less time with convection heat. Preheating is not necessary with foods having a bake time of over 15 minutes.

- Food is heated faster in a convection oven. When using the convection feature, many types of food can be cooked at lower temperatures than those suggested for regular ovens.
- Good for large quantities of baked foods.
- Good results with cookies, biscuits, brownies, cream puffs, sweet rolls, angel food cake and bread.
- Ideal for baked foods cooked on two or three shelves. Because heated air is circulated evenly throughout the oven, foods can be baked with excellent results on two or three shelves at a time. Multi-shelf baking may increase cook times slightly for some foods but the overall result is time saved. Multi-shelf baking provides very good results with cookies, biscuits and other quickbreads.
- Recipe books often give times and temperatures for cooking in regular ovens. Convection ovens make it possible to reduce the temperature by 25–50°F.
- Check foods for doneness at the minimum suggested cooking time.
- Some package instructions for frozen casseroles or main dishes have been developed using commercial convection ovens. For best results in this oven, preheat the oven and use the temperature on the package.

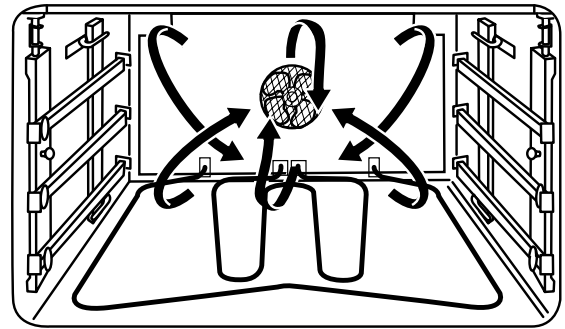

## How to set the oven for convection baking

- 1 Push in the CONV. selector button.
- 2 Using the thermostat dial, set the desired temperature.
  - The OVEN ON light turns on and remains on until the OFF selector button has been pushed.
  - The HEATING light turns on. Once the HEATING light initially cycles off, the oven is preheated.
- 3 Check the food for doneness at the minimum time on the recipe. Cook longer if necessary.
- 4 Push in the OFF selector button when convection baking is finished.



Thermostat dial

## Convection cookware

Before using your convection oven, check to see if your cookware leaves room for air circulation in the oven. If you are baking with several pans, leave space between them. Also, be sure the pans do not touch each other or the walls of the oven. Use the pan size recommended in the recipe.

**When baking cookies**, you will get the best results if you use a flat cookie sheet instead of a pan with low sides.

**For recipes like oven-baked chicken**, you should use a pan with low sides. Hot air cannot circulate well around food in a pan with high sides.

### Metal and Glass

Any type of cookware will work in your convection oven. However, metal pans heat the fastest and are recommended for convection baking.

- Darkened or matte-finished pans will bake faster than shiny pans.
- Glass or ceramic pans cook more slowly.

### Paper and Plastic

Heat-resistant paper and plastic containers that are recommended for use in regular ovens can be used in convection ovens. Plastic cookware that is heat-resistant to temperatures of 400°F. can also be used.



---

## *How to set the oven for broiling*

1 If the meat has fat or gristle around the edge, cut vertical slashes through both about 2 inches apart. If desired, the fat may be trimmed, leaving a layer about 1/8 inch thick.

2 Place the meat or fish on the broiler grid in the broiler pan. Always use the grid so that any fat will drip into the broiler pan; otherwise the juices may become hot enough to catch on fire.

3 Position a shelf on the recommended shelf position as suggested in the Broiling Guide.

4 Leave the door open to the broil stop position. The door stays open by itself, yet the proper temperature is maintained in the oven.

5 Push in the BROIL selector button.

**NOTE:** A cooling fan will be activated when the BROIL selector button is pushed. This cooling fan cools the oven controls when open door broiling. Use caution when reaching into the oven during open door broiling as the drip tray handle may be hot.

6 Turn the thermostat dial to BROIL.

The broiler does not need to be preheated for most broiling. However, foods that cook quickly, such as thin strips of meat or fish may require a short preheating period of 2 to 3 minutes to allow the food surface to brown in the same time the food takes to be cooked throughout.

Turn the food only once during broiling. Time the foods for the first side according to the Broiling Guide.

7 When broiling is finished, push in the OFF selector button.

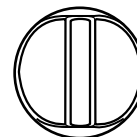
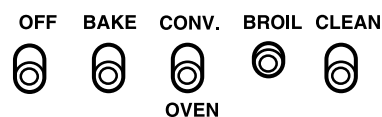

Thermostat dial

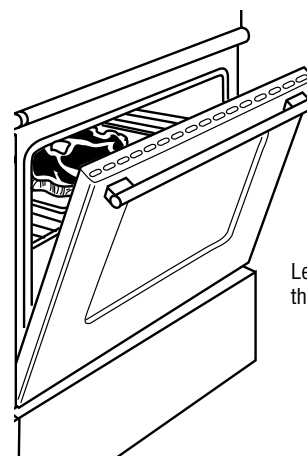

Leave the door open to the broil stop position.

---

## *Aluminum foil*

You can use aluminum foil to line the broiler pan and broiler grid. However, you must mold the foil tightly to the grid and cut slits in it just like the grid.

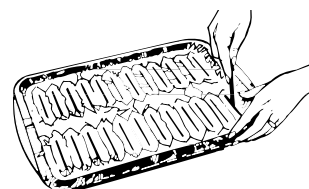

## Using the Oven

*Stainless Steel Range*

### *Broiling guide*

Suggested shelf positions and cooking times are intended as general guidelines only. Experiment with these settings for specific foods and your personal preference.

<b>Food</b>	<b>Quantity/ Thickness</b>	<b>Shelf Position</b>	<b>1st Side Minutes</b>	<b>2nd Side Minutes</b>	<b>Comments</b>
<b>Bacon</b>	1/2 lb. (about 8 thin slices)	C	3-5	3-5	Arrange in single layer.
<b>Ground Beef</b> Well Done	2 lbs. (8 patties) 1/2 to 3/4" thick	B	10-13	7-10	Space evenly. Up to 8 patties take about the same time.
<b>Beef Steaks</b> Rare Medium Well Done	1" thick (1 to 1 1/2 lbs.)	B B B	7 8-10 20-25	7 6-9 15	Steaks less than 1" thick cook through before browning. Pan frying is recommended.
Rare Medium Well Done	1 1/2" thick (2 to 2 1/2 lbs.)	B B A	10 15 25	7-8 14-16 20-25	Slash fat.
<b>Chicken</b>	1 whole (2 to 2 1/2 lbs.), split lengthwise	A	30-35	25-30	Reduce time about 5 to 10 minutes per side for cut-up chicken. Brush each side with melted butter. Broil skin-side- down first.
<b>Bakery Products</b> Bread (Toast) Toaster Pastries English Muffins	2 to 4 slices 1 pkg. (2) 2 (split)	B or C B or C B or C	1 1/2-2 1 1/2-2 4-6	1/2 1/2	Start off using B then switch to C if faster toasting is needed. Space evenly. Place English muffins cut-side-up.
<b>Lobster Tails</b>	2-4 (6 to 8 oz. each)	B	14-18	<i>Do not turn over.</i>	Cut through back of shell. Spread open. Brush with melted butter before broiling and after half of broiling time.
<b>Fish</b>	1-lb. fillets 1/4 to 1/2" thick	B	8-10	5-10	Handle and turn very carefully. Brush with lemon butter before and during cooking, if desired. Preheat broiler to increase browning.
<b>Ham Slices</b> (precooked)	1" thick	B	9	8-10	Increase time 5 to 10 minutes per side for 1 1/2" thick or home cured.
<b>Pork Chops</b> Well Done	2 (1/2" thick) 2 (1" thick), about 1 lb.	B B	15 15-20	10-15 15-18	Slash fat.
<b>Lamb Chops</b> Medium Well Done Medium Well Done	2 (1" thick), 10 to 12 oz. 2 (1 1/2" thick), about 1 lb.	B B B B	8-10 12-15 10-13 17	4-7 8-10 10-12 12-14	Slash fat.
<b>Wieners, Sausages, Bratwurst</b>	1-lb. pkg. (10)	B	6-8	1-4	If desired, split in half lengthwise; cut into 5 to 6" pieces.

# Self-Cleaning Oven

*Stainless Steel Range*

## *Before a clean cycle*

**The range must be completely cool in order to set the self-clean cycle.**

We recommend venting with an open window or using a ventilation fan or hood during the first self-clean cycle.

Remove all cookware and any aluminum foil from the oven.

Remove the oven shelves and shelf slide assembly.

**Make sure the oven light bulb cover is in place and the oven light is off.**

**Do not use commercial oven cleaners or oven protectors in or near the self-cleaning oven.**

## *Oven shelf slide assembly*

An interlock system has been designed so that the self-clean cycle will not start until the shelf slide assemblies have been removed.

The roller-assisted shelf supports are designed to withstand standard baking temperatures.

They will not withstand the extreme temperatures of self-cleaning.

### **To remove the slide assemblies:**

- 1 Loosen the retaining screws on both sides of the oven.
- 2 Lift up slightly and pull the entire assembly out. Set aside.

### **To replace the slide assemblies:**

When self-cleaning is finished, and the oven has cooled, replace the assemblies and retaining screws.

- 1 Guide the rear of the shelf slide assembly into the bottom rear bracket.
- 2 Guide the top rear of the shelf slide assembly into the top "U"-shaped bracket.
- 3 Lift up the push rod so that it rests on the ledge of the side support of the assembly.
- 4 Reattach the assembly securely to the oven with the retaining screw. Repeat for the other side of the oven.

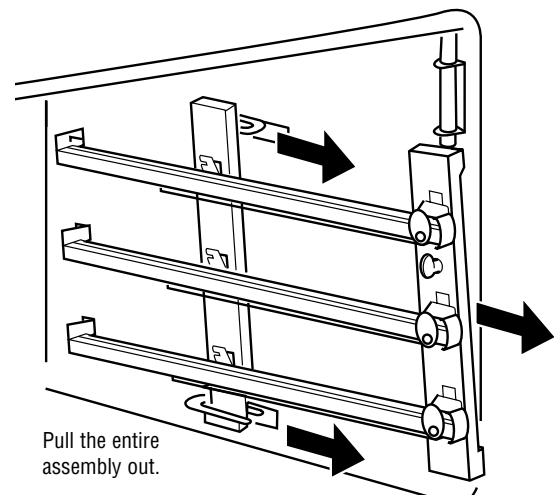
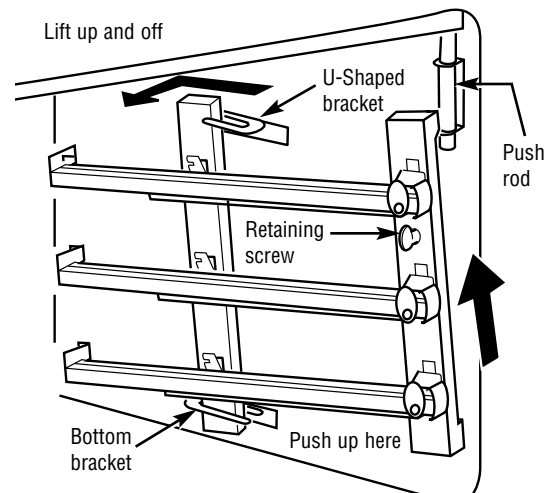

# Self-Cleaning Oven

Stainless Steel Range

## How to set the oven for self-cleaning

The clean cycle takes about 5 hours plus about 30 minutes to cool down.

- 1 Push in the CLEAN selector button.
- 2 Set the thermostat dial to CLEAN.
  - Cooling blower turns on.
  - The OVEN ON light and HEATING light turn on.
  - The DOOR LOCKED light turns on.

- 3 When cleaning has finished, push the OFF selector button.

The blower and the OVEN ON light will turn off once the cycle has finished.

The door latch will open automatically after the oven temperature falls below 550°F.

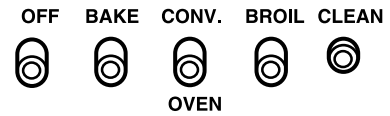

Thermostat dial

## After a clean cycle

**If white spots remain,** remove them with warm sudsy water and rinse thoroughly with a vinegar and water mixture. These deposits are usually a salt residue that cannot be removed by the clean cycle.

**If the oven is not clean after one clean cycle,** repeat the cycle.

**You may notice some white ash in the oven.** Wipe it up with a damp cloth after the oven cools.

## Care and Cleaning

### Stainless Steel Range

---

#### *Control panel and knobs*

Clean up spatters with a damp cloth. Remove heavier soil with warm, soapy water.

Do not use abrasives of any kind on the control panel.

The control knobs may be removed for easier cleaning. To remove a knob, pull it straight off the stem. Wash the knobs in soap and water but do not soak.

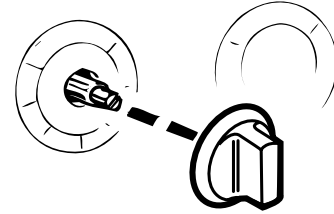

#### *Oven heating elements*

Do not clean the bake elements or the broil elements. Any soil will burn off when the elements are heated.

The bake elements can be lifted gently to clean the oven floor. If spillovers, residue or ash accumulate around the bake elements, gently wipe around the element with warm water.

#### *Oven shelves*

Clean the shelves with an abrasive cleanser or steel wool. After cleaning, rinse the shelves with clean water and dry with a clean cloth.

#### *Drip tray*

Located beneath the cooktop is a drip tray. The drip tray is made of stainless steel and is on rollers, so it is easy to remove and replace.

**To remove the drip tray**, pull it forward. If something has spilled into the tray it should be cleaned up as soon as possible to prevent “baked on” food soil.

Do not allow the grease to accumulate in the drip tray as it can be a fire hazard. Clean the drip tray as soon as it is cool. Clean with hot, soapy water.

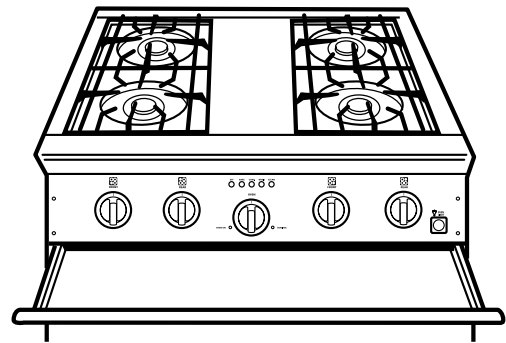

#### Oven light

**NOTE:** The glass cover should be removed only when cold. Wearing latex gloves may offer a better grip.

The light bulb is located on the back of the oven. Before replacing the bulb, disconnect electrical power to the range at the main fuse or circuit breaker panel.

Let the bulb cool completely before removing it. For your safety, do not touch a hot bulb with a damp cloth. If you do, the bulb will break.

**To remove:**

Turn to remove the cover, then remove the bulb.

**To replace:**

Put in a new 40-watt appliance bulb. A 40-watt appliance bulb is smaller than a standard 40-watt household bulb.

Install and tighten the cover.

Reconnect electrical power to the range.

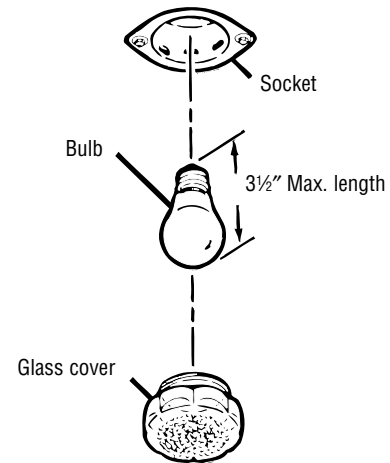

#### Broiler pan and grid

**After broiling,** remove the broiler pan from the oven. Remove the grid from the pan. Carefully pour out the grease from the pan into a proper container. Wash and rinse the broiler pan and grid in hot water with a soap-filled or plastic scouring pad.

**If food has burned on,** sprinkle the grid with detergent while hot and cover with wet paper towels or a dishcloth. Soaking the pan will remove burned-on foods.

The broiler pan may be cleaned with a commercial oven cleaner. The grid is chrome; do not use an oven cleaner to clean it.

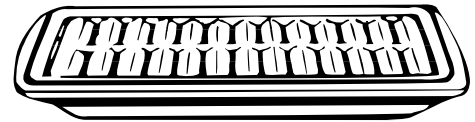

Do not store a soiled broiler pan and grid anywhere in the range.

Both the broiler pan and grid can also be cleaned in the dishwasher.

#### Stainless steel

**Do not use a steel wool pad; it will scratch the surface.**

To clean the stainless steel surface, use a hot, damp cloth with a mild detergent suitable for stainless steel surfaces. Use a clean, hot, damp cloth to remove soap. Dry with a dry, clean cloth.

If food soil remains, try a general kitchen cleaner, such as Fantastik<sup>®</sup>, Simple Green<sup>®</sup> or Formula 409<sup>®</sup>.

For hard-to-clean soil, use a standard stainless steel cleaner, such as Bon-Ami<sup>®</sup> or Cameo<sup>®</sup>.

Apply cleaner with a damp sponge. Use a clean, hot, damp cloth to remove cleaner. Dry with a dry, clean cloth. Always scrub lightly in the direction of the grain.

After cleaning, use a stainless steel polish such as Stainless Steel Magic<sup>®</sup>, Revere Copper and Stainless Steel Cleaner<sup>®</sup>, or Wenol All Purpose Metal Polish<sup>®</sup>. Follow the product instructions for cleaning the stainless steel surface.

## *Burner assembly*

The burner assemblies should be washed regularly and, of course, after spills.

Turn all the controls to OFF before removing the burner parts.

The electrode of the spark ignitor is exposed beyond the top of the burner. When cleaning the burner tray, be careful not to snag the electrode of the spark ignitor with your cleaning cloth. Do not hit the spark ignitor. Be careful not to turn on any surface controls while cleaning the burner tray. A slight electrical shock might result which could cause you to knock over hot cookware.

The burner grates and burner caps can be lifted off, making them easy to clean. Removing them gives you access to the burner bases.

To avoid snagging cloth on spark ignitors, leave burner caps in place when cleaning the burner tray.

The burners have been designed in two pieces for ease of cleaning. When the burner grate and the burner are cool, remove the grate. The burner caps can easily be lifted off. Wash these parts in hot soapy water, rinse and dry thoroughly.

A bristle brush can be used to clean out the burner ports, if necessary.

The burner grates are porcelain enamel. When cool they may be wiped clean using hot, soapy water, then rinsed and wiped dry. When lifting the burner grates, be careful as they are heavy. Place them on a protected surface, so they won't scratch the surface of the cooktop.

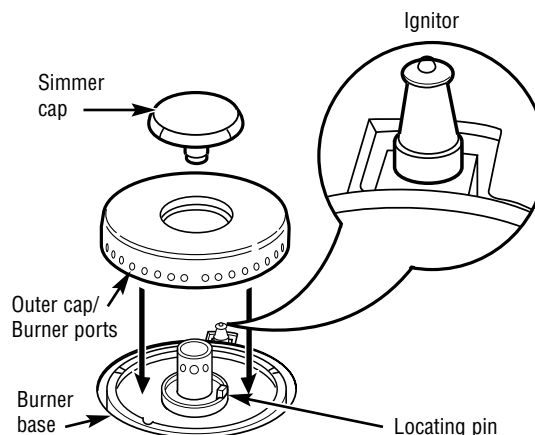

### **CAUTION:**

Do not operate the burner without all burner parts in place.

**After cleaning, it is important to make sure the indentation on the bottom side of the outer cap/burner port is properly aligned with the corresponding locating pin in the burner base. Incorrect alignment will produce poor burner performance.**

# The Problem Solver

*Stainless Steel Range*

*Questions?  
Use this  
problem  
solver!*

<b>PROBLEM</b>	<b>POSSIBLE CAUSE</b>
<b>SURFACE BURNERS DO NOT LIGHT</b>	<ul style="list-style-type: none"> <li>· Burners assembled incorrectly after cleaning. Make sure the burner assembly is put together correctly and that the outer caps/burner ports are aligned.</li> <li>· Ports blocked in the outer cap near the ignitor. Clean and reassemble. See “Burner assembly” in the Care and Cleaning section.</li> <li>· Inspect the manual cut-off valve to insure that it is not closed.</li> <li>· Make sure the electrical plug is plugged into a live power outlet.</li> <li>· Check for a power outage.</li> </ul>
<b>SURFACE BURNER FLAMES VERY LARGE OR YELLOW</b>	<ul style="list-style-type: none"> <li>· Improper air/gas ratio in burners. Call for service.</li> </ul>
<b>TICKING SOUND OF SPARK IGNITOR AFTER SURFACE BURNER LIGHTS</b>	<ul style="list-style-type: none"> <li>· The spark ignitor is not deactivated. Turn the burner OFF and relight. Some ticking is normal. If ticking is excessive, call for service.</li> </ul>
<b>STRONG ODOR FROM SURFACE BURNERS</b>	<ul style="list-style-type: none"> <li>· Improper air/gas ratio in surface burners. Call for service.</li> </ul>
<b>OVEN LIGHT DOES NOT WORK</b>	<ul style="list-style-type: none"> <li>· The light bulb is loose or defective. Tighten or replace the bulb.</li> <li>· The switch operating light is broken. Call for service.</li> </ul>
<b>FOOD DOES NOT BAKE OR ROAST PROPERLY</b>	<ul style="list-style-type: none"> <li>· The oven controls are improperly set. See the “How to set your oven for baking or roasting” section.</li> <li>· Incorrect cookware or cookware of improper size being used. See the “How to set your oven for baking or roasting” section.</li> <li>· Use a foil tent to slow down browning during roasting.</li> </ul>
<b>FOOD DOES NOT BROIL PROPERLY</b>	<ul style="list-style-type: none"> <li>· The oven control is not set at BROIL.</li> <li>· The oven door is not open to the broil stop position as recommended.</li> <li>· Improper shelf position being used. See the Broiling Guide.</li> <li>· Food is being cooked in a hot pan.</li> <li>· Cookware is not suited for broiling. Use the broiling pan and grid that came with your range.</li> <li>· Aluminum foil used on the broiling pan and grid has not been fitted properly and slit as recommended.</li> <li>· In some areas the power (voltage) may be low. Preheat the broil element for 10 minutes. Broil for the longest period of time recommended in the Broiling Guide.</li> </ul>
<b>OVEN WILL NOT WORK</b>	<ul style="list-style-type: none"> <li>· Plug on the range is not completely inserted in the electrical outlet.</li> <li>· A fuse in your home may be blown or the circuit breaker tripped.</li> <li>· The oven controls are not properly set.</li> <li>· The oven controls are set for cleaning. If necessary, allow the oven to cool, then open the door.</li> </ul>
<b>OVEN WILL NOT SELF-CLEAN</b>	<ul style="list-style-type: none"> <li>· The oven temperature is too high to set a self-clean operation. Allow the range to cool to room temperature and reset the controls.</li> <li>· The controls are not properly set.</li> <li>· The self-clean cycle will not start until the shelf slide assemblies have been removed.</li> </ul>
<b>“CRACKING” OR “POPPING” SOUND DURING CLEANING</b>	<ul style="list-style-type: none"> <li>· This is normal. This is the sound of the metal heating and cooling during both the cooking and cleaning functions.</li> </ul>
<b>EXCESSIVE SMOKING OCCURS DURING CLEANING</b>	<ul style="list-style-type: none"> <li>· Excessive soil. Press the OFF selector button. Open the windows to rid the room of smoke. Wait until the DOOR LOCKED light goes off. Wipe up excess soil and reset the clean cycle.</li> </ul>
<b>STRONG ODOR FROM SELF-CLEAN CYCLE</b>	<ul style="list-style-type: none"> <li>· An odor from the insulation around the inside of the oven is normal for the first few times the oven is used. This is temporary.</li> </ul>
<b>OVEN NOT CLEAN AFTER A CLEAN CYCLE</b>	<ul style="list-style-type: none"> <li>· The oven was heavily soiled. Clean up heavy spillovers before starting the clean cycle. Heavily soiled ovens may need to self-clean again.</li> <li>· The oven controls are not properly set. See the Self-Cleaning section.</li> </ul>



*With the purchase of your new Monogram appliance, receive the assurance that if you ever need information or assistance from GE, we'll be there. All you have to do is call—toll-free!*

---

## ***GE Answer Center®***

**800.626.2000**

Whatever your question about any Monogram major appliance, GE Answer Center® information service is available to help. Your call—and your question—will be answered promptly and courteously. And you can call any time. GE Answer Center® service is open 24 hours a day, 7 days a week.

OR

Visit our Website at: [www.monogram.com](http://www.monogram.com)

---

## ***In-Home Repair Service***

***In the U.S.A. :  
800.444.1845***

***In Canada :  
888.880.3030***

A GE consumer service professional will provide expert repair service, scheduled at a time that's convenient for you. Many GE Consumer Service company-operated locations offer you service today or tomorrow, or at your convenience (7:00 a.m. to 7:00 p.m. weekdays, 9:00 a.m. to 2:00 p.m. Saturdays). Our factory-trained technicians know your appliance inside and out—so most repairs can be handled in just one visit.

---

## ***For Customers With Special Needs...***

**800.626.2000**

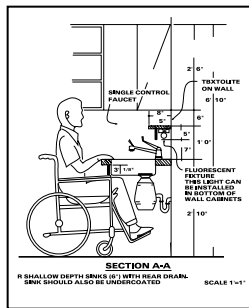

GE offers, free of charge, a brochure to assist in planning a barrier-free kitchen for persons with limited mobility.

Consumers with impaired hearing or speech who have access to a TDD or a conventional teletypewriter may call 800.TDD.GEAC (800.833.4322) to request information or service.

---

## ***Service Contracts***

**800.626.2224**

You can have the secure feeling that GE Consumer Service will still be there after your warranty expires. Purchase a GE contract while your warranty is still in effect and you'll receive a substantial discount. With a multiple-year contract, you're assured of future service at today's prices.

---

## ***Parts and Accessories***

**800.626.2002**

Individuals qualified to service their own appliances can have parts or accessories sent directly to their home. The GE parts system provides access to over 47,000 parts...and all GE Genuine Renewal Parts are fully warranted. VISA, MasterCard and Discover cards are accepted.

**User maintenance instructions contained in this manual cover procedures intended to be performed by any user. Other servicing generally should be referred to qualified service personnel. Caution must be exercised, since improper servicing may cause unsafe operation.**

## ***YOUR MONOGRAM RANGE WARRANTY***

***Staple sales slip or cancelled check here. Proof of original purchase date is needed to obtain service under warranty.***

---

### ***WHAT IS COVERED***

#### **FULL ONE-YEAR WARRANTY**

For one year from date of original purchase, we will provide, free of charge, parts and service labor in your home to repair or replace **any part of the range** that fails because of a manufacturing defect.

#### **LIMITED FIVE-YEAR WARRANTY**

For five years from the date of original purchase, we will provide, free of charge, replacement **gas surface burners** if they fail in normal household use. (The oven burners are not included.) You pay for the service trip to your home and all service labor charges.

.....  
This warranty is extended to the original purchaser and any succeeding owner for products purchased for ordinary home use in the 48 mainland states, Hawaii and Washington, D.C. In Alaska the warranty is the same except that it is LIMITED because you must pay to ship the product to the service shop or for the service technician's travel costs to your home.

All warranty service will be provided by our Factory Service Centers or by our authorized Customer Care® servicers during normal working hours.

Should your appliance need service, during warranty period or beyond, in the U.S.A. call 800.444.1845. In Canada: 888.880.3030.

### ***WHAT IS NOT COVERED***

- Service trips to your home to teach you how to use the product.
- Chipping of porcelain enamel grates.
- Replacement of house fuses or resetting of circuit breakers.
- Incidental or consequential damage caused by possible defects with this appliance.

· **Damage to the product caused by accident, fire, floods or acts of God.**

· **Failure of the product if it is used for other than its intended purpose or used commercially.**

· **Improper installation.**

**If you have an installation problem, contact your dealer or installer. You are responsible for providing adequate electrical, gas, exhausting and other connecting facilities as described in the Installation Instructions provided with the product.**

---

Some states do not allow the exclusion or limitation of incidental or consequential damages, so the above limitation or exclusion may not apply to you. This warranty gives you specific legal rights, and you may also have other rights which vary from state to state.

To know what your legal rights are in your state, consult your local or state consumer affairs office or your state's Attorney General.

**Warrantor: General Electric Company. If further help is needed concerning this warranty, write: Manager—Customer Relations, GE Appliances, Louisville, KY 40225**

**Consumer Product  
Ownership Registration**  
Important Mail Today

*GE Appliances*



Place  
1st Class  
Letter  
Stamp  
Here

**General Electric Company**  
Warranty Registration Department  
P.O. Box 32150  
Louisville, KY 40232-2150

# Consumer Product Ownership Registration

Dear Customer:

Thank you for purchasing our product and thank you for placing your confidence in us. We are proud to have you as a customer!

**Follow these three steps to protect your new appliance investment:**

**1** Complete and mail your Consumer Product Ownership Registration today. Have the peace of mind of knowing we can contact you in the unlikely event of a safety modification.

**2** After completing this registration, write your model and serial numbers in this manual. You will need this information should you require service. The service number in the USA: 800.444.1845. In Canada: 1.888.880.3030.

**3** Read your Owner's Manual carefully. It will help you operate your new appliance properly.

**Important:** To ensure that your product is registered, mail the separate product registration card. If the separate product registration card is missing, fold and mail the form below. No envelope is needed.

FOLD HERE

## Consumer Product Ownership Registration



Product  
Range

Model

Serial

Mr.  Ms.  Mrs.  Miss

First Name \_\_\_\_\_ Last Name \_\_\_\_\_

Street Address \_\_\_\_\_

Apt. # \_\_\_\_\_

City \_\_\_\_\_ State \_\_\_\_\_ Zip Code \_\_\_\_\_

Date Placed In Use \_\_\_\_\_ Day \_\_\_\_\_ Year \_\_\_\_\_ Phone Number \_\_\_\_\_ - \_\_\_\_\_ - \_\_\_\_\_



Occasionally, we may allow selected companies to send you information.  
 Check here if you do not want this information.



TAPE CLOSED

17383
Part No. 164D4290P031
Pub No. 49-80073

02-01 JR

Printed in the United States