

BravettiTM

300 Watt Power Mixer Use and Care Instructions Model EP545

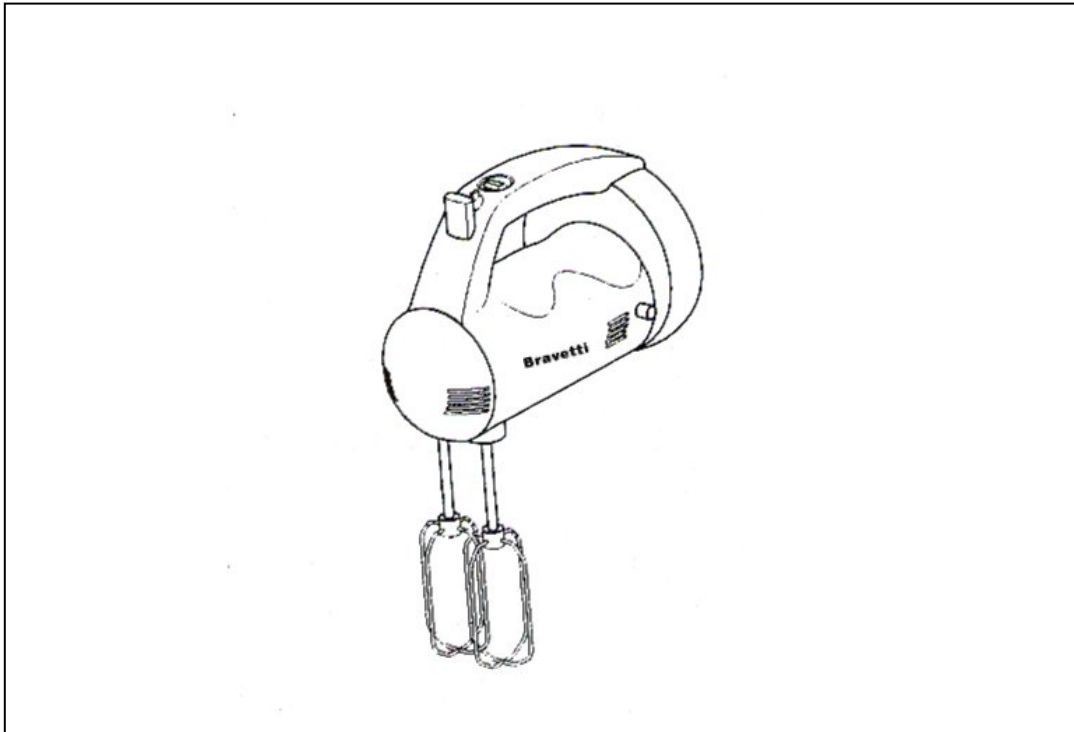

For information or assistance:

EURO-PRO Operating LLC

Boston, MA 02465

Tel.: 1 (800) 798-7398

www.euro-pro.com

IMPORTANT SAFEGUARDS

When using electrical appliances, basic safety precautions should always be followed, including the following:

1. Read all instructions before using the appliance.
2. To protect against risk of electrical shock, do not put cord, plug or mixer in water or other liquid.
3. Close supervision is necessary when appliance is used by or near children.
4. Unplug appliance from outlet when not in use, before putting on or taking off parts, and before cleaning.
5. Avoid contact with moving parts at all times. Keep hands, hair, clothing, as well as spatulas and other utensils away from beaters during operation to prevent personal injury and/or damage to the mixer.
6. Do not operate any appliance with a damaged cord or plug or after the appliance malfunctions, or is dropped or damaged in any manner. Return appliance to nearest authorized service facility for examination, repair or electric or mechanical adjustment.
7. The use of attachments not recommended or sold by **EURO-PRO Operating LLC** may cause fire, electric shock or injury.
8. Do not use outdoors.
9. Do not let cord hang over edge of table or counter or touch hot surfaces, including the stove.
10. Remove beaters, dough hooks and whisk from mixer before cleaning.
- 11. DO NOT USE THIS APPLIANCE ON A STOVE.**
12. Do not use appliance for other than intended use.
13. The mixer is designed for intermittent use. It can be run for up to 10 minutes on setting 1 - 3 without interruption. Do not use for more than 30 seconds on the turbo setting: allow the motor to cool afterwards.
14. To avoid injury by accidentally switching on the appliance when inserting the dough hooks, beaters or whisk, always set the switch to position 'OFF' (0) and unplug the appliance before assembling or disassembling.
15. Use only on appropriate voltage AC outlets. (See rating plate on bottom of appliance).

IMPORTANT NOTICE

This appliance has a polarized plug (one blade is wider than the other). To reduce the risk of electric shock, this plug will fit in a polarized outlet only one way. If the plug does not fit fully in the outlet, reverse the plug. If it still does not fit, contact a qualified electrician. Do not modify the plug in any way.

SAVE THESE INSTRUCTIONS
THIS APPLIANCE IS FOR HOUSEHOLD USE ONLY

Bravetti 300 Watt Power Mixer

Main Components

1. Main Housing
2. Beater Release Button
3. Speed Selector
4. Turbo Button
5. Beater Openings
6. Mixer Beaters
7. Dough Hooks
8. Cord Rewinding Button
9. Whisk
10. Gear

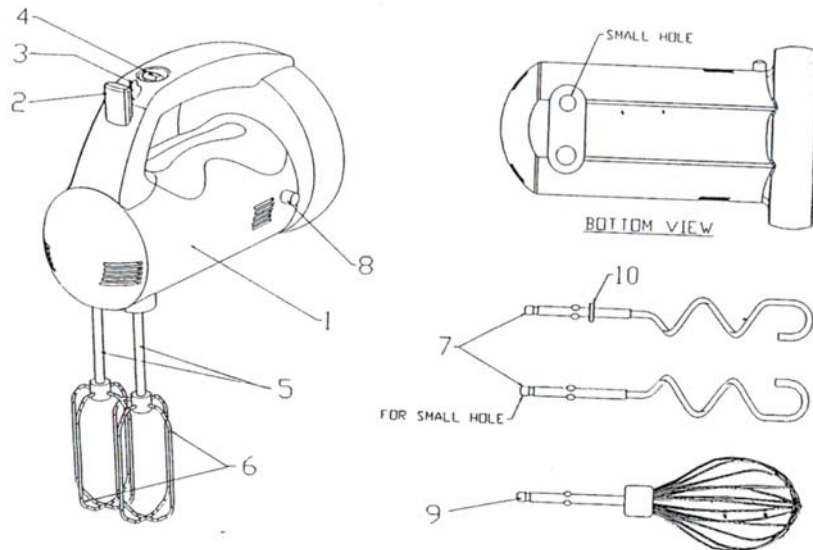

CAUTION: Do not pull with force on power cord or you will damage the rewinding feature and void warranty.

Congratulations! As the owner of a new **Bravetti** hand mixer, you are about to use a very versatile and powerful kitchen mixing tool. You will enjoy 300 watts of power, four convenient speeds including turbo button for extra surge of power at any speed.

INSTRUCTIONS FOR USE

Before using your **Bravetti** mixer for the first time, wash the beaters, dough hooks, whisk and bowl in warm, sudsy water. Rinse and dry thoroughly.

TO USE HAND MIXER

A. To insert beaters, dough hooks or whisk (6,7, 9)

Make sure that the mixer is unplugged from power source and speed selector is set on 'OFF' (0) before inserting or removing beaters, dough hooks or whisk. Always insert the attachments (6,7,9) with the gear (10) into the larger hole.

Select the attachment according to the type of mix required.

Beaters: (6) For liquid mixes such as creams, egg-whites, cookie doughs, etc.

Insert beaters (6) one at a time, by placing stem end of beaters into opening on bottom of mixer (5). Place beater with gear (10) into the larger hole. Press beater in gently and rotate slightly until beater clicks into place. Gently tug on beaters to ensure they are secured properly.

Dough hooks: (7) For light doughs.

To insert dough hooks: Insert dough hooks (7) in the same way as beaters above. Always use both dough hooks. Never try to work with one beater and one dough hook at the same time.

Do not use dough hooks at low speeds as this may cause motor to overheat. When using dough hooks for heavy or thick dough, use only high speed (3) from the beginning to prevent the motor from overheating (blocking).

Whisk: (9) The whisk is used to beat air into mixtures such as egg whites, yolks or cream. Insert the whisk into the large hole.

IMPORTANT: The dough hook with the gear must be inserted into the larger opening. Otherwise, dough may climb up the dough hook

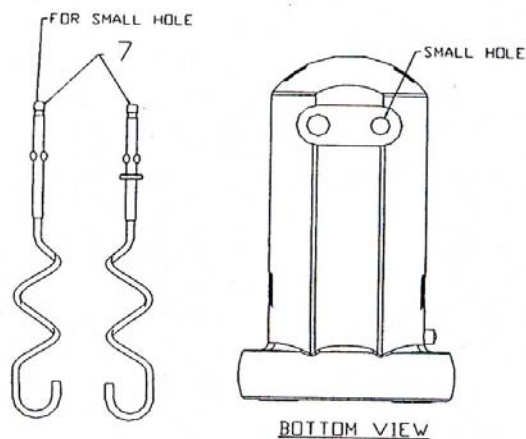

To Operate Mixer

- Gently pull out the power cord from the main housing. Do not pull too hard or you may damage the auto-rewind function.
- Before plugging in the unit, fit the elements necessary for the mixing operation to be carried out: Use beaters (6) to beat liquids such as creams, egg whites, cake and cookie mixes.
- Insert beaters (6) one at a time in beater openings (5) by pressing them gently upwards until they are fully fitted (a click will be heard).
- When finished, remove beaters by pressing beater release button (2). Use Dough Hooks (7): to mix light dough. Use whisk (9) to whip eggs, egg whites, etc.

IMPORTANT: The dough hook with the gear must go into the larger opening, otherwise the dough may overflow.

- When you have chosen the accessories to be used, plug the mixer in the outlet.
- Pick the mixer up and use your thumb to set the speed selector (3) to the setting you require:
 - 0: Off
 - 1: Low speed
 - 2: Average speed
 - 3: High speed
- The Turbo control (4) enables the mixer to run at top speed for a few seconds (maximum 30). With the speed selector (3) set to the required position, hold down button (4) to run mixer.
- We suggest that you begin at high speed (3) to prevent the motor from blocking.
- Ensure that the beaters are completely free to move in your recipient.
- Return to setting 0 when you have finished mixing or to stop
- To remove the beaters, dough hooks or whisk (6, 7 or 9) from the main housing (1) press the release button (2): this button works only when the mixer is set to "0".
- Push the Cord winding button (8), the power cord **will** rewind automatically.

Cleaning and Maintenance

- Ensure that the mixer is unplugged and switched "Off" (0) before cleaning.
- Clean the beaters, dough hooks and whisk (6, 7 & 9) in soapy warm water or the dishwasher,
- Use a damp cloth to clean the main housing.
- NEVER submerge the unit in water.



ONE (1) YEAR LIMITED WARRANTY

EURO-PRO Operating LLC warrants this product to be free from defects in material and workmanship for a period of one (1) year from the date of purchase when utilized for normal household use.

If your appliance fails to operate properly while in use under normal household conditions within the warranty period, return the complete appliance and accessories, freight prepaid to **EURO-PRO Operating LLC**. Call customer service at 1 (800) 798-7398. If the appliance is found by **EURO-PRO Operating LLC** to be defective in material or workmanship, **EURO-PRO Operating LLC** will repair or replace it free of charge. Proof of purchase date and \$ 6.95 to cover the cost of return shipping and handling must be included.*

The liability of **EURO-PRO Operating LLC** is limited solely to the cost of the repair or replacement of the unit at our option. This warranty does not cover normal wear of parts and does not apply to any unit that has been tampered with or used for commercial purposes. This limited warranty does not cover damage caused by misuse, abuse, negligent handling or damage due to faulty packaging or mishandling in transit.

This warranty is extended to the original purchaser of the unit and excludes all other legal and/or conventional warranties. The responsibility of **EURO-PRO Operating LLC** if any, is limited to the specific obligations expressly assumed by it under the terms of the limited warranty. **In no event is EURO-PRO Operating LLC** liable for incidental or consequential damages of any nature whatsoever. Some states do not permit the exclusion or limitation of incidental or consequential damages, so the above may not apply to you.

This warranty gives you specific legal rights, and you may also have other rights which vary from state to state.

***Important:** Carefully pack item to avoid damage in shipping. Be sure to include proof of purchase date and to attach tag to item before packing with your name, complete address and phone number with a note giving purchase information, model number and what you believe is the problem with item. We recommend you insure the package (as damage in shipping is not covered by your warranty). Mark the outside of your package "ATTENTION CUSTOMER SERVICE".



OWNERSHIP REGISTRATION CARD

Please fill out and mail the product registration card within ten (10) days of purchase in order to validate the foregoing Limited Warranty. The registration will enable us to contact you in the unlikely event of a product safety notification. By returning this card you acknowledge to have read and understood the instructions for use, and warnings set forth in the accompanying instructions.

RETURN TO: EURO-PRO Operating LLC, Boston, MA 02465

Appliance model

Date purchased

Name of store

Owner's name

Address

City

State

Zip code