



# VINO-1500SS VINO-1900SS

## Installer's Instruction

 <b>WARNING</b>	
	<p>Always check wiring harness connections before initiating any test procedures.</p> <p>Disconnect electric power from the appliance before performing any maintenance or repairs.</p> <p>Voltage checks should be made by inserting meter probes beside the wires in the connector blocks with the electric power source on and the connector block plugged in.</p> <p>Resistance checks should be made on components with the electric power off and the connector block disconnected.</p>

**Federal law requires that WINEMATE split cooling systems be installed by an EPA certified refrigeration technician.**

WINEMATE split system is shipped as components and is ready for use only after a certified refrigeration technician has properly installed, charged and tested the system. Proper installation is critical. Vinotemp can only warrant the quality of the components. The installation and proper operation of the system must be warranted by the installer. Installation of the system must be done in accordance with all state and local building codes.

The condensing unit and evaporator unit are connected by a liquid line and an insulated suction line that are supplied by the installer. These lines must be properly sized for the distance between the two units. After the units and the lines are installed, the system must be pressure tested. If no leaks are found, evacuate and charge system with R134A. Refrigerant amount will vary depending on the length of line set.

### 1. Condensing Unit

- Place the condensing unit WM-150SCU in a properly ventilated location. If it is not, heat exhausted by the condensing unit will build up and the cooling system will not operate properly.
- Leave minimum 5 feet clearance for the exhaust side and leave minimum 1 foot clearance for the fresh air intake side.
- Condensing unit shall be elevated to avoid possible flooding and shaded from direct sun. It shall not be exposed to temperatures higher than 110 °F or lower than 45 °F (optional low ambient kit for 20 °F).

## 2. Evaporator Unit

- The WM-15SFC evaporator unit is installed for ceiling mount with the air supply towards horizontally and air return on the bottom.
- The WM-19SFC evaporator unit is installed for wall mount with the air supply towards top and air return on the sides.
- Supply and return air flow from the evaporator unit shall be unobstructed for at least 1 foot.
- There is a gravity drain line so that it can not be installed above the evaporator unit. Otherwise a condensation pump must be used.

## 3. Refrigeration Piping and Charging

**NOTES: ALWAYS USE THE SUPERHEAT AND SUBCOOLING, PRESSURE READINGS TO CHARGE REFRIGERANT PROPERLY, THE LISTED CHARGES ARE FOR REFERENCE ONLY.**

- The installation order starts from condensing unit (including the receiver), liquid line filter-drier, moisture-liquid indicator (sight glass), liquid line, evaporator unit (including liquid line solenoid valve and thermostatic expansion valve or automatic expansion valve), returning to suction line and condensing unit.
- The subcooling at the condensing unit shall be around 10°F. The charge may be complete when there are no more bubbles forming in the sight glass.
- The evaporator superheat is set around 8-10 °F for a 10 °F TD system at factory.
- Low side pressure: around 33 psig
- High side pressure: 130 -150 psig at 75 -90 °F ambient temperatures

The line sizes and refrigerant charges are listed as follows.

MODEL	REFRIGERATION LINES	LIQUID LINE	SUCTION LINE	DRAIN LINE	CHARGE
VINO-1500SS	< 50 FT	1/4" OD	3/8" OD	1/2" OD	R134a/ 15 OZ
VINO-1900SS	< 50 FT	1/4" OD	3/8" OD	3/8" OD	R134a/ 15 OZ

## 4. Pressure, Superheat and Subcooling Readings

**NOTES: THE SERVICE VALVES MUST BE IN THE MIDDLE POSITIONS TO READ PROPERLY.**

Complaint	Possible Causes
a. High suction pressure and low head pressure b. High suction pressure and low head pressure Low superheat and low subcooling	a. Compressor may be bad b. Expansion valve opened, too much oil

<ul style="list-style-type: none"> <li>c. High suction pressure and high head pressure Low superheat and high subcooling</li> <li>d. High to normal suction pressure and high head pressure Low subcooling</li> <li>e. High suction pressure and high head pressure Low subcooling</li> <li>f. High suction pressure and high head pressure High superheat</li> <li>g. Low suction pressure and low head pressure High superheat and low subcooling</li> <li>h. Low suction pressure and low to normal head pressure High superheat and high subcooling</li> <li>i. Low suction pressure and low head pressure Low subcooling</li> <li>j. Low suction pressure and low head pressure Low superheat and low subcooling</li> <li>k. Low suction pressure and low to normal head pressure High superheat and normal to high subcooling</li> <li>l. Low suction pressure and normal head pressure High superheat and normal subcooling</li> <li>m. Low suction pressure and high head pressure High superheat and high subcooling</li> <li>n. Low suction pressure and high head pressure High superheat and high subcooling</li> <li>o. low to normal suction pressure and high head pressure High to normal superheat and high subcooling</li> </ul>	<ul style="list-style-type: none"> <li>c. Overcharge</li> <li>d. Non-condensable gas</li> <li>e. Air restricted, dirty condenser, bad condenser fans</li> <li>f. High room temperature, high evaporator load</li> <li>g. Undercharge</li> <li>h. Liquid line restricted after receiver, solenoid valve restricted</li> <li>i. Suction line restricted</li> <li>j. Air restricted at evaporator, evaporator iced</li> <li>k. Evaporator restricted</li> <li>l. Expansion valve restricted</li> <li>m. Both evaporator and condenser restricted</li> <li>n. Liquid line restricted before receiver</li> <li>o. Condenser restricted</li> </ul>
--	--

### 5. Valve Operation

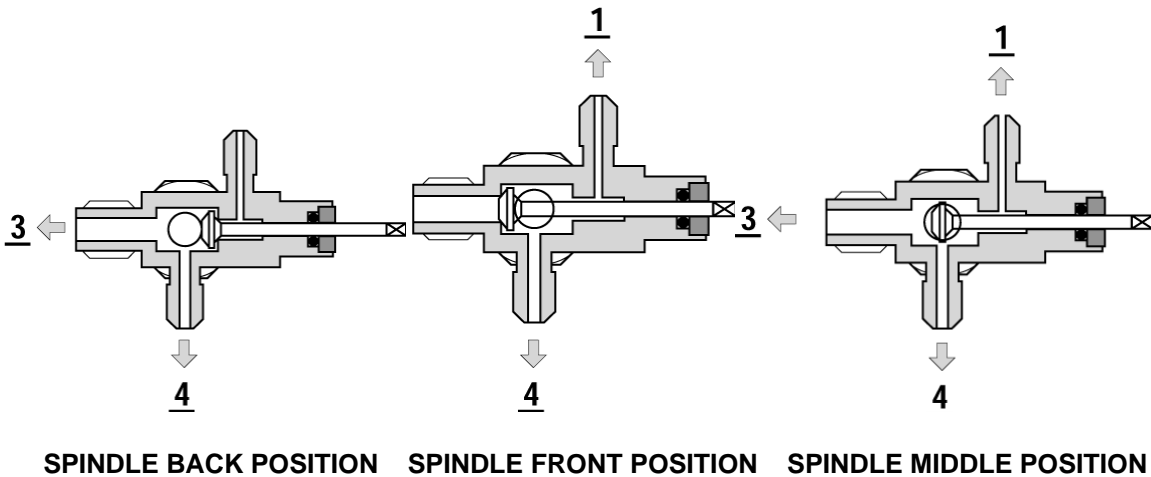
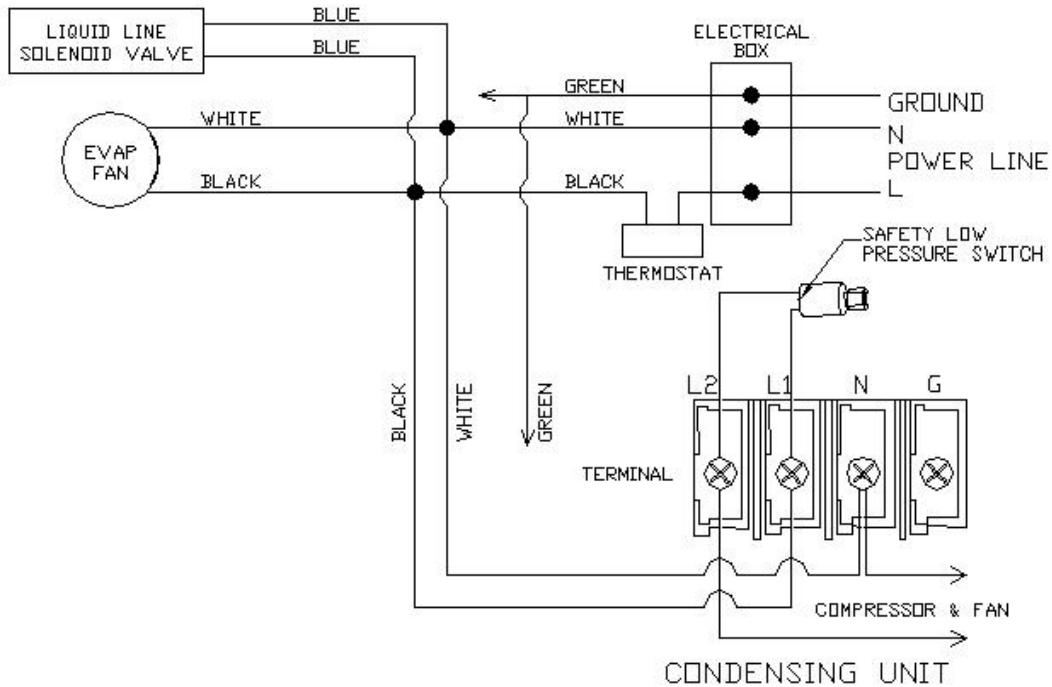

**Fig. 2.1 Valve Operation**

- Back Position:** Process and manometer port closed for normal operation
- Front Position:** Main connection to liquid or suction line closed
- Middle Position:** All ports open for vacuum, charge and measurement

## 6. Electrical Wiring

### EVAPORATOR UNIT



**Fig. 2.2 VINO1500-1900SS Electrical Wiring Diagram**

## 7. Use of the adjustable low pressure control (if applicable)

Cut out = 5 psig; Cut in = 25 psig; Differential = 20 psig

It may need to adjust the setting in the field to get the right cycle time.

### Step 1. Set high event by adjusting range screw.

**All-Range Controls:** Turn screw clockwise to raise high event.

**MICRO-SET Controls:** Turn screw clockwise to lower CUT IN setpoint.

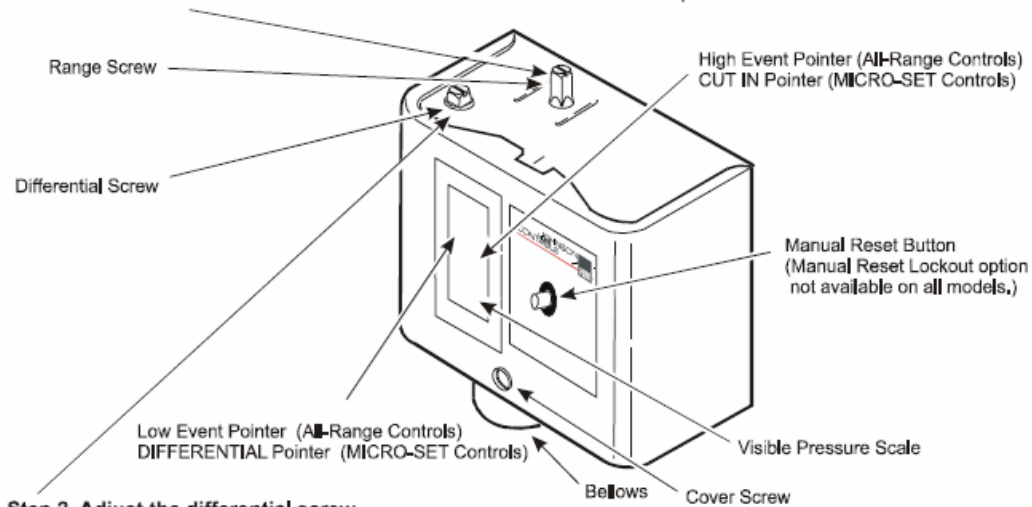

### Step 2. Adjust the differential screw.

**All-Range Controls:** Turning the differential screw changes the low event.

Turn screw clockwise to lower Low Event.

**MICRO-SET Controls:** Turning the differential screw changes the differential setting.

Turn screw clockwise to increase DIFFERENTIAL.

**Fig. 2.3 Adjustable Pressure Control**

## 8. Condensing Unit Troubleshooting

Unit not running	
a. Incorrect power supply	a. Check for proper voltage
b. Incorrect or loose wirings	b. Check all wirings and connections
c. Failed components	c. Check start relay, start capacitor, overload protector, compressor.
d. Liquid refrigerant in the compressor	d. Call service for OEM information
e. Low pressure switch shutting down the system	e. Check for system restriction or low refrigerant