

Description

Thank you for purchasing the Campbell Hausfeld 70 amp Arc Welder, Model #WS090001AV. This instruction sheet is to be used in conjunction with the standard owner's manual included with the welder (IN198904AV). Please refer to this sheet for WS090001AV assembly instructions.

▲ NOTICE

Please read all warning instructions in the owner's manual before operating.

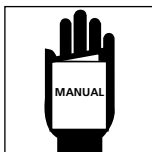

Components

The WS090001 comes with the following additional equipment:

- Automatic amperage adjustment - low position for 1/16" rods and high position for 5/64" rods--for ease of use.
- Cable storage clips (shown in Handle Assembly) for safer storage of welding cables.

Handle Assembly

1. Align the end holes on the handle with the holes on top of the welder, then secure with screws (Figure 1).

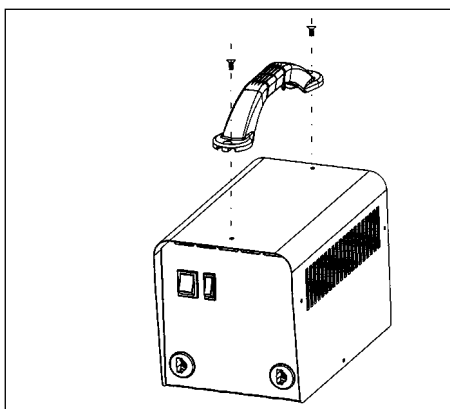

Figure 1

2. Insert cable clips by pressing inward on sides of clip and pushing into the slots on front of handle as shown in Figure 2. Repeat for opposite side of handle.

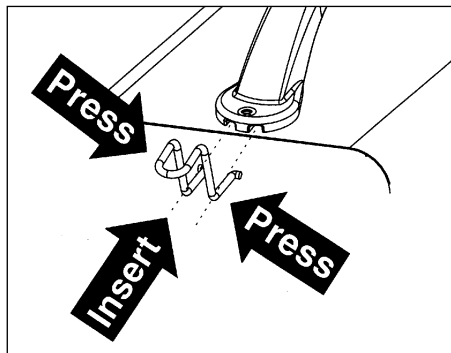

Figure 2

Electrode Holder Assembly

(Refer to Figure 3)

1. Remove insulation handle from the holder body by pulling the two

pieces apart.

2. Slide the other weld cable through the handle.
3. Loosen the wire clamping screw and slide the bare cord wire under the clamp block. Tighten the clamping screw and make sure the wire is secure.
4. Slide the handle over the electrode holder body and press to stop. Make sure the handle is secure and there is no exposed metal on the holder.

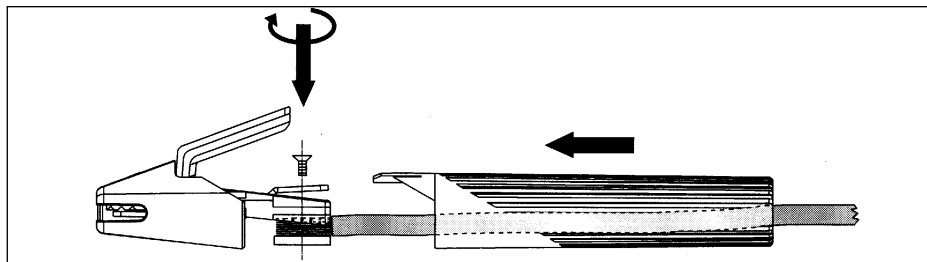

Figure 3 - Electrode Holder

For Replacement Parts, call 1-800-746-5641

Please provide following information:

- Model number
- Serial number (if any)
- Part description and number as shown in parts list

Address parts correspondence to:

The Campbell Group
 Attn: Parts Department
 100 Production Drive
 Harrison, Ohio 45030

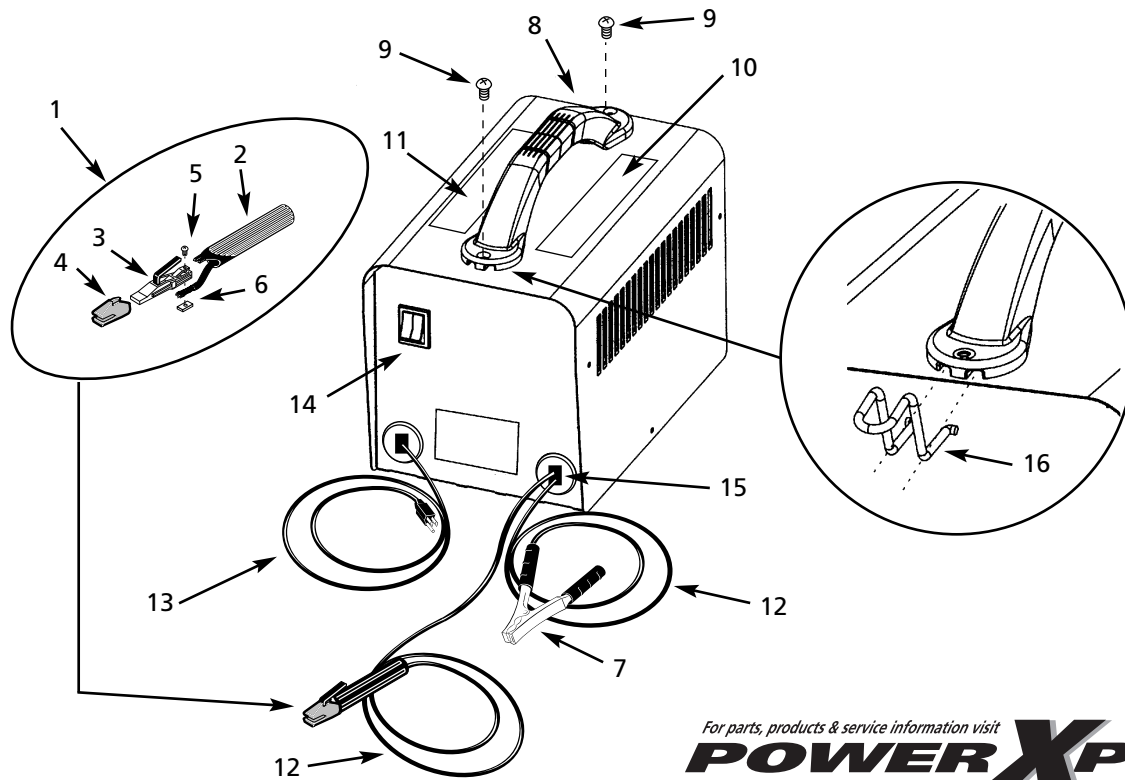

For parts, products & service information visit
POWER XPERT
 www.campbellhausfeld.com

Ref. No.	Description	Part Number for WS090001	Qty
1	Electrode holder assembly - cord not included (includes ref. # 2-7)	WC200000AV	1
2	Electrode holder handle - cord not included	WC200001AV	1
3	Electrode holder body	WC200002AV	1
4	Insulation cap	WC200003AV	1
5	#10-24 x .5" machine screw	*	1
6	#10-24 x 7/16" square nut	*	1
7	Work clamp	WC100300AV	1
8	Handle	WC301300AV	1
9	#8-36 x 3/4" pan head screw	*	2
10	Safety decal (right)	DK404300AV	1
11	Safety decal (left)	DK404400AV	1
12	Welding cable 6 AWG (6 ft)	*	2
13	Power cord 14-3 AWG (6 ft) Type SJT	WC000100AJ	1
14	High/off/low thermal indicator	WC401000AV	1
15	Strain relief	WC102000AV	2
16	Cord storage clip	WC301301AV	2

* Standard hardware item, available at local hardware or welder supply store