

HEALTHRIDER

SOFT STRIDER EX

SOFT TRACK CUSHIONED TREADMILL

USER'S MANUAL

Model No. 831.297871

Serial No. _____

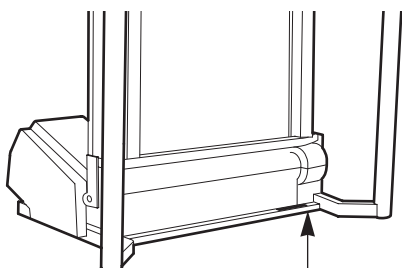

Serial Number Decal

SEARS, ROEBUCK AND CO.,
HOFFMAN ESTATES, IL 60179

CAUTION

Read all precautions and instructions in this manual before using this equipment. Save this manual for future reference.



TABLE OF CONTENTS

IMPORTANT PRECAUTIONS	2
BEFORE YOU BEGIN	4
SETTING UP THE TREADMILL	5
HOW TO USE THE HAND PULSE SENSOR	6
GROUNDING INSTRUCTIONS	7
CONSOLE OPERATION	8
HOW TO FOLD AND MOVE THE TREADMILL	16
TROUBLE-SHOOTING AND MAINTENANCE	17
CONDITIONING GUIDELINES	19
ORDERING REPLACEMENT PARTS	Back Cover
FULL 90 DAY WARRANTY	Back Cover

IMPORTANT PRECAUTIONS

⚠ WARNING: To reduce the risk of burns, fire, electric shock, or injury to persons, read the following important precautions and information before operating the treadmill.

1. It is the responsibility of the owner to ensure that all users of this treadmill are adequately informed of all warnings and precautions.
2. Use the treadmill only as described in this manual.
3. Place the treadmill on a level surface, with eight feet of clearance behind it. Do not place the treadmill on any surface that blocks air openings. To protect the floor or carpet from damage, place a mat under the treadmill.
4. Keep the treadmill indoors, away from moisture and dust. Do not put the treadmill in a garage or covered patio, or near water.
5. Do not operate the treadmill where aerosol products are used or oxygen is administered.
6. Keep children under the age of 12 and pets away from the treadmill at all times.
7. The treadmill should not be used by persons weighing more than 250 pounds. Never allow more than one person at a time on the treadmill.
8. Wear appropriate exercise clothing when using the treadmill. Do not wear loose clothing that could become caught in the treadmill. Athletic support clothes are recommended for both men and women.
9. Always wear athletic shoes when using the treadmill—never use the treadmill with bare feet, wearing only stockings, or in sandals. For maximum walking belt life, never use shoes with heavy treads.
10. When connecting the power cord (see page 7), plug the power cord into a surge suppressor (not included) and plug the surge suppressor into a grounded circuit capable of carrying 15 or more amps. No other appliance should be on the same circuit. Do not use an extension cord.
11. Use a single-outlet surge suppressor that is UL 1449 listed as a transient voltage surge suppressor (TVSS). The surge suppressor must have a UL suppressed voltage rating of 400 volts or less and a minimum surge dissipation of 450 joules. The surge suppressor must be electrically rated for 120 volts AC and 15 amps.
12. Keep the power cord and the surge suppressor away from heated surfaces.
13. Never move the walking belt while the power is turned off. Do not operate the treadmill if the power cord or plug is damaged, or if the treadmill is not working properly. (See BEFORE YOU BEGIN on page 4 if the treadmill is not working properly.)
14. Never start the treadmill while you are standing on the walking belt.
15. Always hold the handrails when walking or running on the treadmill.
16. The treadmill is capable of high speeds; adjust the speed in small increments to avoid sudden jumps in speed.
17. To reduce the possibility of the treadmill overheating, do not operate the treadmill continuously for longer than one hour.
18. Never leave the treadmill unattended while it is running. Always remove the key, unplug the power cord and move the on/off switch to the off position when the treadmill is not in use. (See the drawing on page 5 for the location of the on/off switch.)
19. Never drop or insert any object into any opening.
20. When operating the treadmill, keep hands and feet from underneath the treadmill.
21. The hand pulse sensor is not a medical device. Various factors, including the user's movement, may affect the accuracy of heart rate readings. The hand pulse sensor is intended only as an exercise aid in determining heart rate trends in general.

22. Do not attempt to raise, lower, or move the treadmill until it is properly assembled. (See ASSEMBLY on page 5 and HOW TO MOVE THE TREADMILL on page 16.) You must be able to safely lift 45 pounds (20 kg) to raise, lower, or move the treadmill.

23. When folding or moving the treadmill, make sure that the storage latch is fully engaged.

24. Inspect and tighten all parts of the treadmill every three months.

25. **DANGER:** Always unplug the power cord immediately after use, before cleaning the treadmill, and before performing the maintenance and adjustment procedures described in this manual. Never remove the motor hood unless instructed to do so by an authorized service representative. Servicing other than the procedures in this manual should be performed by an authorized service representative only.

26. The treadmill is intended for in-home use only. Do not use the treadmill in any commercial, rental, or institutional setting.

⚠ WARNING: Before beginning this or any exercise program, consult your physician. This is especially important for persons over the age of 35 or persons with pre-existing health problems. Read all instructions before using. SEARS assumes no responsibility for personal injury or property damage sustained by or through the use of this product.

SAVE THESE INSTRUCTIONS

The decals shown have been placed on your treadmill. If a decal is missing, or if it is not legible, please call our toll-free HELPLINE to order a free replacement decal (see the back cover of this manual). Apply the decal in the location shown.

IMPORTANT:
Incline must be set at lowest level before folding treadmill into storage position.

⚠ WARNING

- Never allow children on or around treadmill.
- Storage latch must be fully engaged before treadmill is moved or stored.

⚠ WARNING

KEEP HANDS AND FEET AWAY FROM THIS AREA WHILE THE TREADMILL IS IN OPERATION.

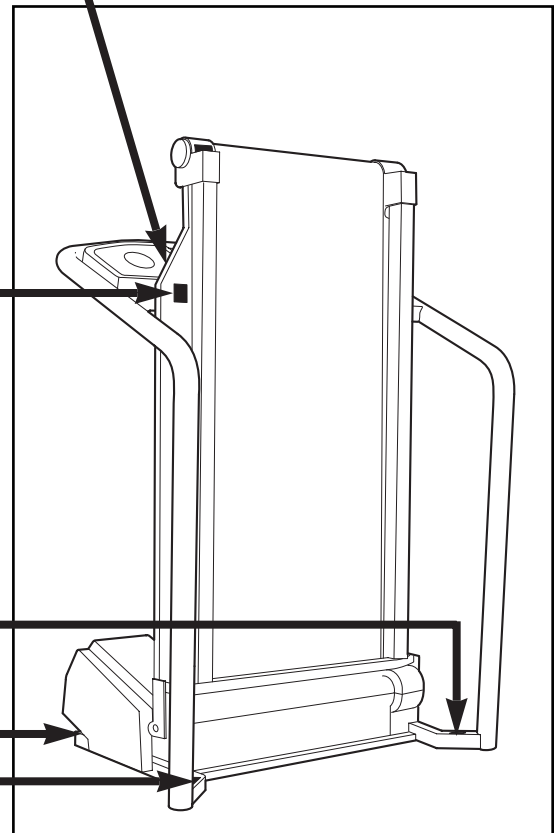

BEFORE YOU BEGIN

Congratulations for purchasing the SOFTSTRIDER EX™ treadmill by HealthRider. The SOFTSTRIDER EX offers an impressive array of features that will help you to achieve your fitness goals in the convenience of your home. From the advanced console to the ultra-soft walking belt, the SOFTSTRIDER EX is designed to make each workout more effective and enjoyable. And when you're not exercising, the SOFTSTRIDER EX can be folded away, taking less than half the space of conventional treadmills.

For your benefit, read this manual carefully before using the SOFTSTRIDER EX treadmill. If you have

additional questions, please call our toll-free HELPLINE at 1-800-736-6879, Monday through Saturday, 7 a.m. until 7 p.m. Central Time (excluding holidays). To help us assist you, please note the product model number and serial number before calling. The model number of the treadmill is 831.297871. The serial number can be found on a decal attached to the treadmill (see the front cover of this manual for the location).

Before reading further, please review the drawing below and familiarize yourself with the parts that are labeled.

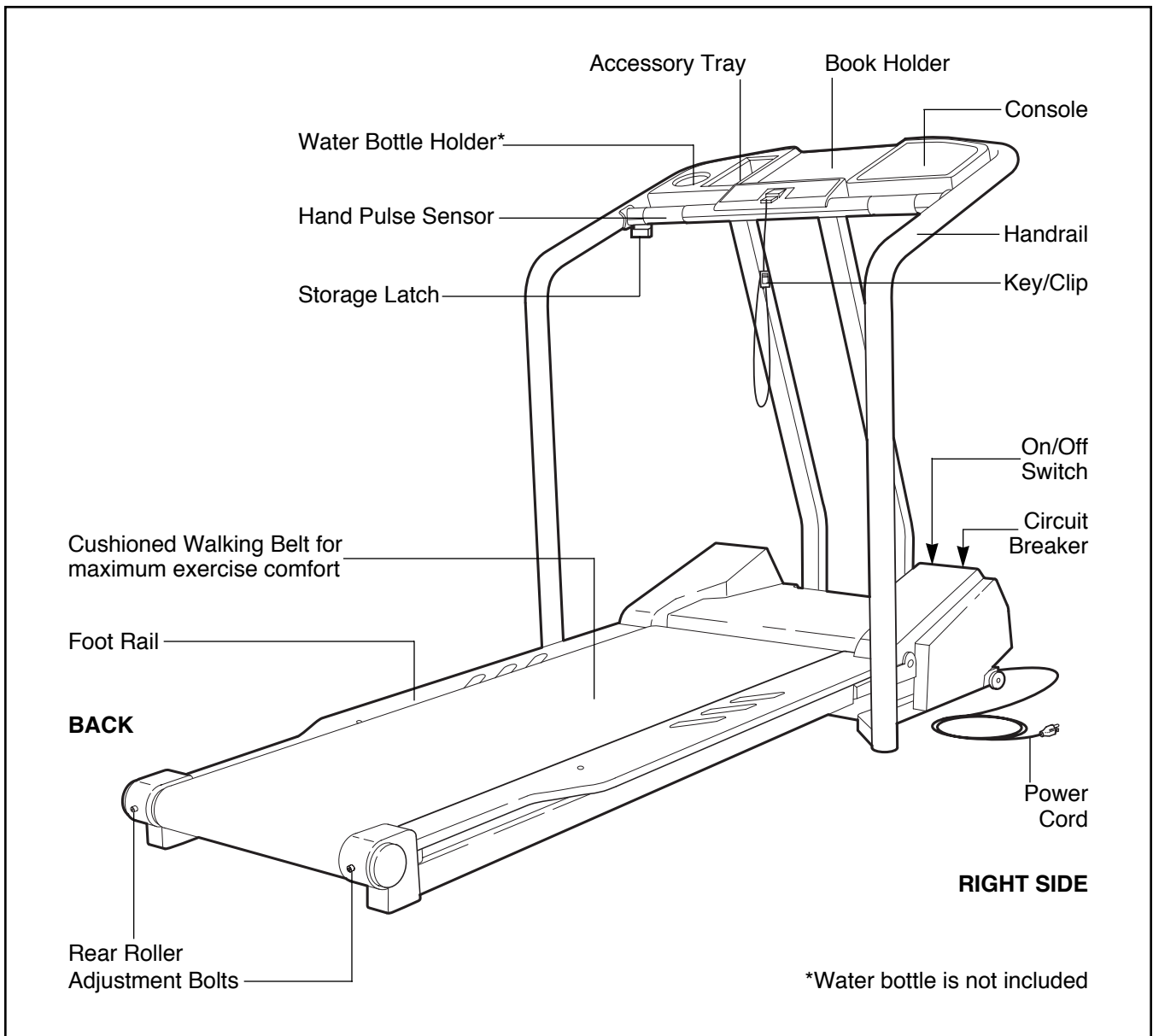

ASSEMBLY

Assembly requires two people. Place the treadmill in a cleared area and remove all packing materials. Do not dispose of the packing materials until assembly is completed. No tools are required.

1. **With the help of a second person,** carefully raise the Uprights (82) until the Front Wheels (77) are resting on the floor as shown.

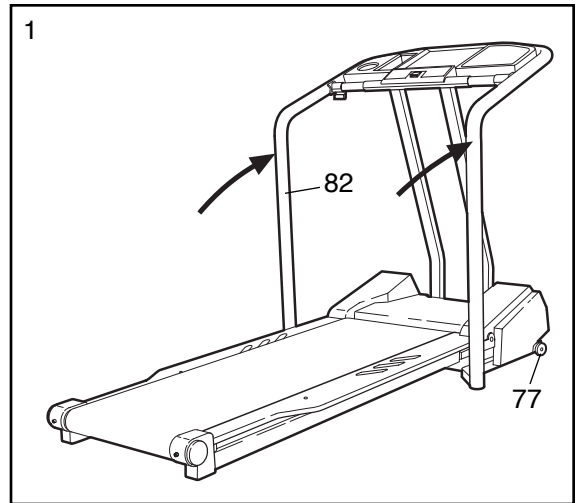

2. Remove the paper backing from the Wrench Clip (71). Press the Wrench Clip onto the Frame (92) in the indicated location. Press the Allen Wrench (72) into the Wrench Clip. Note: The use of the Allen Wrench is described on pages 17 and 18.

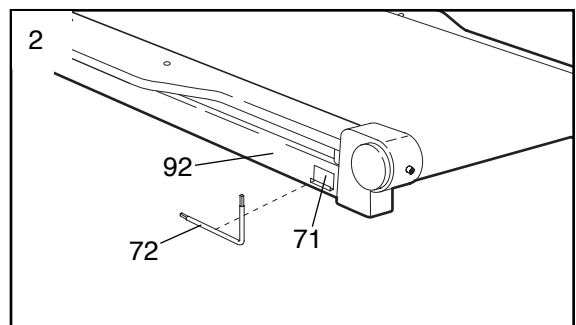

3. **Make sure that all parts are tightened before you use the treadmill. Place a mat beneath the treadmill to protect the floor or carpet.**

HOW TO USE THE HAND PULSE SENSOR

The convenient hand pulse sensor allows you to measure your heart rate before you begin exercising, during your workout, and again when you finish.

To use the hand pulse sensor, the console must be turned on (see HOW TO TURN ON THE POWER on page 9). In addition, the walking belt must be moving or the TIME display must be flashing (see step 5 on page 10).

To measure your heart rate, stand on the foot rails and place your hands on the metal contacts as shown. Your palms must be resting on the upper contacts, and your fingers must be touching the lower contacts—avoid

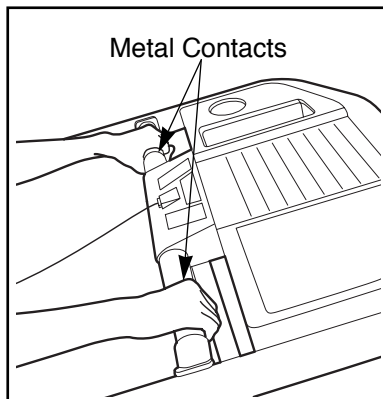

moving your hands. After a moment, three dashes (— — —) will appear in the PULSE display and your heart rate will be shown. Continue to hold the contacts for about 15 seconds for the most accurate heart rate reading.

HAND PULSE SENSOR TROUBLE-SHOOTING

- Stand on the foot rails and avoid moving your hands while measuring your heart rate. Excessive movement may interfere with heart rate readings. If the hand pulse sensor is not used correctly, three dashes (— — —) will appear repeatedly in the PULSE display but your heart rate will not be shown.
- Do not hold the metal contacts too tightly; doing so may interfere with heart rate readings.
- Continue to hold the contacts for about 15 seconds for the most accurate heart rate reading.
- For optimal performance of the hand pulse sensor, keep the metal contacts clean. The contacts can be cleaned with a soft cloth—never use alcohol, abrasives, or chemicals.

OPERATION AND ADJUSTMENT

THE PERFORMANT LUBE™ WALKING BELT

Your treadmill features a walking belt coated with PERFORMANT LUBE™, a high-performance lubricant.

IMPORTANT: Never apply silicone spray or other substances to the walking belt or the walking platform. Such substances will deteriorate the walking belt and cause excessive wear.

HOW TO PLUG IN THE POWER CORD

⚠ DANGER: Improper connection of the equipment-grounding conductor can result in an increased risk of electric shock. Check with a qualified electrician or serviceman if you are in doubt as to whether the product is properly grounded. Do not modify the plug provided with the product—if it will not fit the outlet, have a proper outlet installed by a qualified electrician.

Your treadmill, like any other type of sophisticated electronic equipment, can be seriously damaged by sudden voltage changes in your home's power. Voltage surges, spikes, and noise interference can result from weather conditions or from other appliances being turned on or off. **To decrease the possibility of your treadmill being damaged, always use a surge suppressor with your treadmill (see drawing 1 at the right).**

Surge suppressors are sold at most hardware stores and department stores. Use only a single-outlet surge suppressor that is UL 1449 listed as a transient voltage surge suppressor (TVSS). The surge suppressor must have a UL suppressed voltage rating of 400 volts or less and a minimum surge dissipation of 450 joules. The surge suppressor must be electrically rated for 120 volts AC and 15 amps.

This product must be grounded. If it should malfunction or break down, grounding provides a path of least resistance for electric current to reduce the risk of electric shock. This product is equipped with a cord having an equipment-grounding conductor and a grounding plug. **Plug the power cord into a surge suppressor, and plug the surge suppressor into an appropriate outlet that is properly installed and grounded in accordance with all local codes and ordinances.**

This product is for use on a nominal 120-volt circuit, and has a grounding plug that looks like the plug illustrated in drawing 1 below. A temporary adapter that looks like the adapter illustrated in drawing 2 may be used to connect the surge suppressor to a 2-pole receptacle as shown in drawing 2 if a properly grounded outlet is not available.

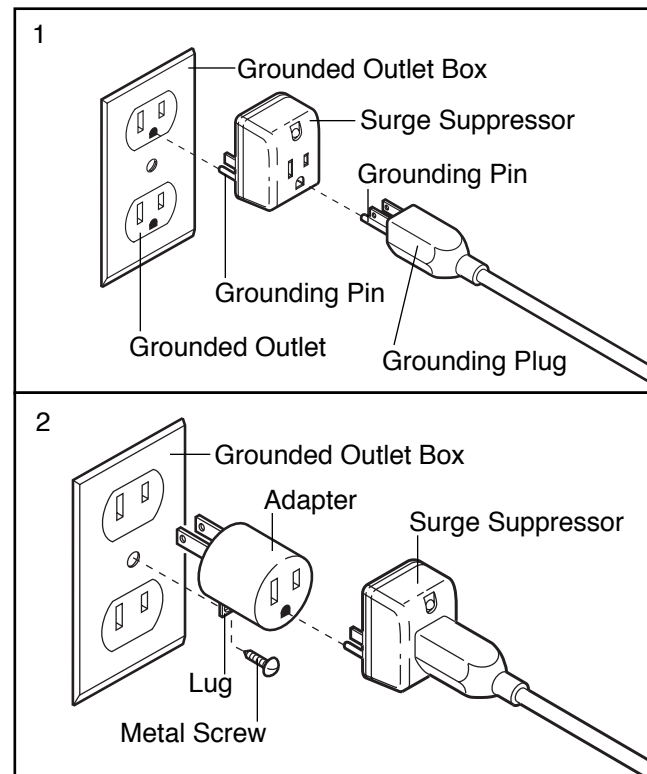

The temporary adapter should be used only until a properly grounded outlet (drawing 1) can be installed by a qualified electrician.

The green-colored rigid ear, lug, or the like extending from the adapter must be connected to a permanent ground such as a properly grounded outlet box cover. Whenever the adapter is used it must be held in place by a metal screw. **Some 2-pole receptacle outlet box covers are not grounded. Contact a qualified electrician to determine if the outlet box cover is grounded before using an adapter.**

CONSOLE OPERATION

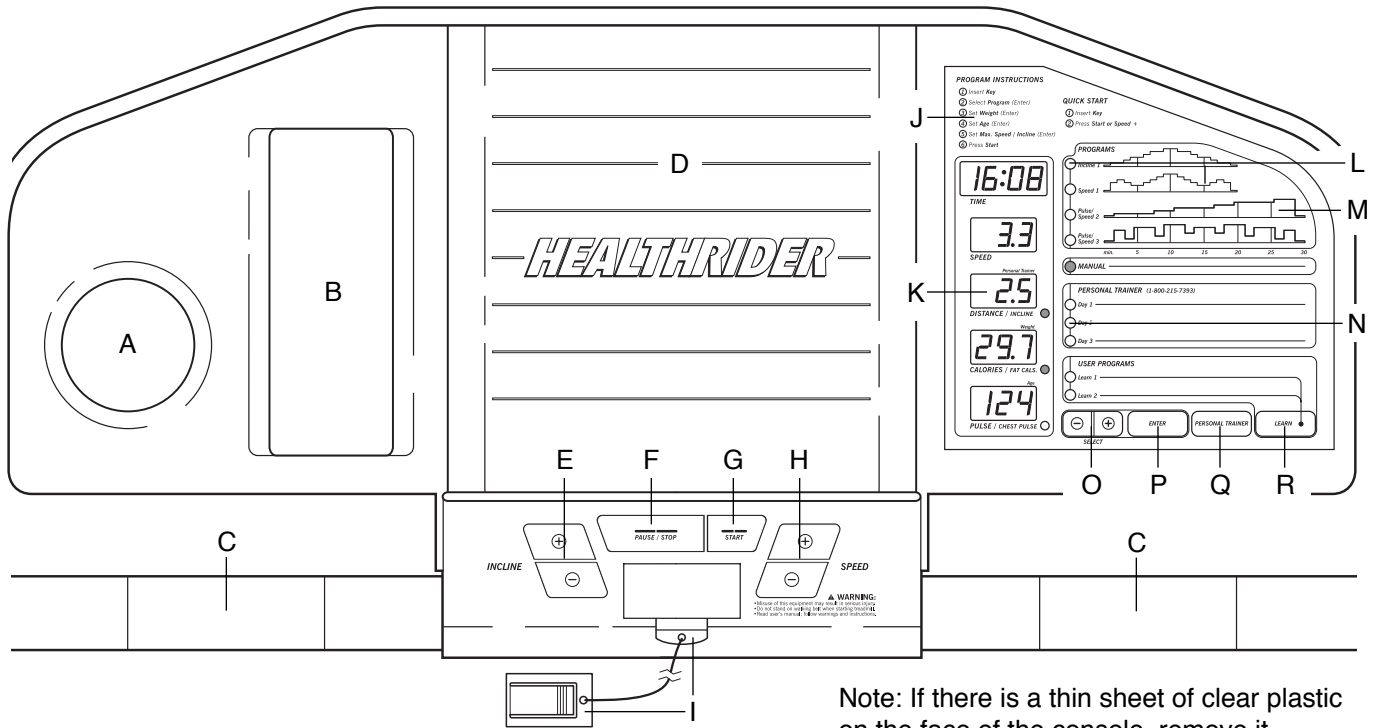

Note: If there is a thin sheet of clear plastic on the face of the console, remove it.

⚠ CAUTION: Before operating the console, read the following precautions.

- Do not stand on the walking belt when turning on the power or starting the walking belt.
- Always wear the clip (see I above) while operating the treadmill. If the key is pulled from the console, the walking belt will stop.
- The treadmill is capable of high speeds; adjust the speed in small increments.
- To reduce the risk of electric shock, keep the console dry. Avoid spilling liquid on the console and use only a sealable water bottle.

FEATURES OF THE CONSOLE

The advanced console offers a wide array of features designed to make your workouts more enjoyable and effective.

When the console is in the manual mode, the speed and incline of the treadmill can be changed with a

touch of a button. As you exercise, the LED displays will provide continuous exercise feedback. And with the built-in hand pulse sensor, you can check your heart rate at any time during your workouts.

The console also offers four preset workout programs. One program automatically controls the incline of the treadmill and the other three programs control the speed of the treadmill as they guide you through effective workouts. You can even create your own workout programs and store them in memory for future use.

An optional chest pulse sensor adds even more features to the console. The chest pulse sensor continuously monitors your heart rate during your workouts, and adds two workout programs to the console—one program for intensive fat-burning, and one for maximum cardiovascular benefits.

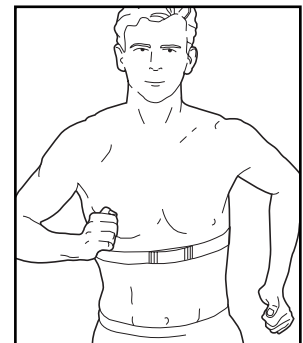

To purchase the optional chest pulse sensor, refer to the card accompanying the treadmill.

DIAGRAM OF THE CONSOLE

Refer to the drawing at the top of page 8.

- A. Water Bottle Holder—Keeps your water bottle handy during your workouts.
- B. Accessory Tray—Holds your personal items.
- C. Hand Pulse Sensor—Allows you to measure your heart rate before you begin exercising, during your workout, and again when you finish.
- D. Reading Rack—Allows you to enjoy your favorite magazine or read a book while you get in shape.
- E. INCLINE Buttons—These buttons control the incline of the treadmill. Each time a button is pressed, the incline will change by 0.5%. The incline range is 2% to 10%.
- F. PAUSE/STOP Button—This button stops the walking belt. When the button is pressed, the TIME, DISTANCE/INCLINE, and CALORIES/FAT CALORIES displays will pause. If the button is held down for two seconds, the displays will be reset.
- G. START Button—This button starts the walking belt.
- H. SPEED Buttons—These buttons control the speed of the walking belt. Each time a button is pressed, the speed will change by 0.1 mph. The speed range is 0.5 mph to 10 mph.
- I. Key with Clip—The key turns the console on and off. The attached clip is designed to be worn on your waistband. If the key is pulled from the console, the power will automatically turn off.
- J. Operating Instructions—These instructions list the basic steps of console operation.
- K. LED Displays—The upper four displays provide continuous feedback of the elapsed time, speed, distance, incline, and the numbers of calories and fat calories you have burned. The lower display shows your heart rate when the hand pulse sensor or the optional chest pulse sensor is used.
- L. MANUAL/Program Indicators—These indicators show when the manual mode is selected and when one of the workout programs is selected.

- M. Program Profiles—These profiles show how the incline or speed of the treadmill will change during workout programs. During the Incline 1 program, for example, the incline will gradually increase during the first half of the program, and then gradually decrease during the last half.
- N. Personal Trainer Program Indicators—Please disregard these indicators. Personal trainer programs are not available for this console. Note: Your console may not have these indicators.
- O. SELECT Buttons—These buttons are used to make various selections on the console.
- P. ENTER Button—This button is used to enter selections.
- Q. PERSONAL TRAINER Button—Please disregard this button. Personal trainer programs are not available for this console. Note: Your console may not have this button.
- R. LEARN Button—This button is used to program the Learn 1 and Learn 2 programs.

HOW TO TURN ON THE POWER

Make sure that the on/off switch, located on the front of the treadmill, is in the “on” position.

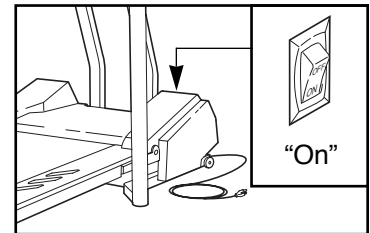

Next, make sure that the power cord is properly plugged in (see page 7). Note: If the key is in the console when the power cord is plugged in, the letters “PO” will flash in the CALORIES/FAT CALORIES display. If this occurs, remove the key.

Step onto the foot rails of the treadmill. Find the clip attached to the key, and slide the clip onto the waistband of your clothing. Next, insert the key fully into the console. The MANUAL indicator will begin to flash; all other indicators and displays will remain dark.

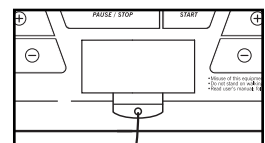

HOW TO USE THE MANUAL MODE

1 Insert the key into the console.

See HOW TO TURN ON THE POWER on page 9.

Note: When you are familiar with the console, you may go directly to step 5. While learning to use the console, please read all steps.

2 Select the MANUAL mode.

When the key is inserted, the MANUAL indicator will begin to flash. To select the manual mode, press the ENTER button while the MANUAL indicator is flashing. (Note: If a program has been selected, hold down the PAUSE/STOP button for two seconds until the MANUAL indicator is flashing.)

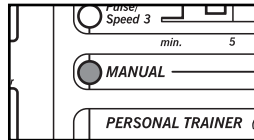

3 Enter your weight if desired.

When the manual mode is selected, the TIME display will light and a weight setting will begin to flash in the CALORIES/FAT CALORIES display. If you enter your weight into the console, the CALORIES/FAT CALORIES display will be more accurate.

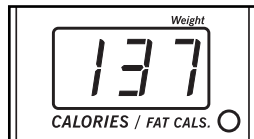

If you do not want to enter your weight, press the ENTER button. To enter your weight, press the SELECT buttons. Each time a button is pressed, the weight setting will change by 1 pound. If a button is held down, the weight setting will change in increments of 5 pounds. When the correct weight is shown, press the ENTER button. Once your weight is entered, it will be saved in memory.

4 Enter your age if desired.

After a weight setting is entered, an age setting will begin to flash in the PULSE display. It is not necessary to enter your age unless you use the optional chest pulse sensor and an optional pulse program.

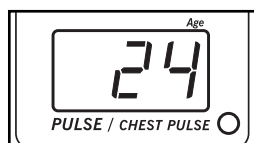

If you do not want to enter your age, press the ENTER button. If you want to enter your age, press the SELECT buttons. Each time a button is

pressed, the age setting will change by 1 year. If a button is held down, the age setting will change in increments of 5 years. When the correct age is shown, press the ENTER button. Once your age is entered, it will be saved in memory.

5 Press the START button or the SPEED + button.

A moment after the button is pressed, the walking belt will begin to move at 1.0 mph. Hold the handrails and begin walking. As you exercise, change the speed of the walking belt as desired with the SPEED buttons. Each time a button is pressed, the speed will change by 0.1 mph. The speed range of the walking belt is 0.5 mph to 10.0 mph.



To stop the walking belt for a moment, press the PAUSE/STOP button. The displays will pause and the TIME display will begin to flash. To restart the walking belt, press the START button or the SPEED + button. Note: To stop the walking belt and reset all displays, hold down the PAUSE/STOP button for two seconds. The console will then be in the same state as if the key had just been inserted.

Note: When one of the SPEED buttons is pressed, the SPEED display will show the selected speed setting for seven seconds. The display will then show the actual speed of the walking belt.

6 Adjust the incline as desired.

To vary the intensity of your exercise, the incline of the treadmill can be changed with the INCLINE buttons. Each time a button is pressed, the incline will change by 0.5%. The incline range is 2% to 10%. Note: After the INCLINE buttons are pressed, it may take a moment for the treadmill to reach the selected incline setting. When one of the INCLINE buttons is pressed, the DISTANCE/INCLINE display will show the incline setting for seven seconds.

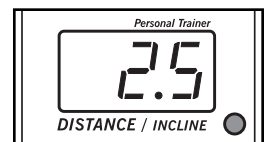

7 Follow your progress with the LED displays.

TIME display—This display shows the total time that the walking belt has been moving. Note: When a workout program is selected, this display will show the time remaining in the program.



SPEED display—This display shows the speed of the walking belt, in miles per hour or kilometers per hour.



How to select miles per hour and kilometers per hour:

Hold down the PAUSE/STOP button while inserting the key into the console. An "E" (for english miles) or an "M" (for metric kilometers) will appear in the SPEED display. Press the SPEED + button to change the unit of measurement. Remove and then reinsert the key.

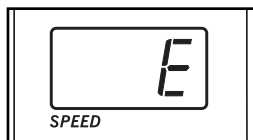

DISTANCE/INCLINE display

—This display shows the distance that the walking belt has moved and the incline level of the treadmill.

Every seven seconds, the display will change from one number to the other. The INCLINE indicator will light when the incline is shown. Note: If the speed is shown in mph, the distance will be shown in miles. If the speed is shown in kph, the distance will be shown in kilometers.

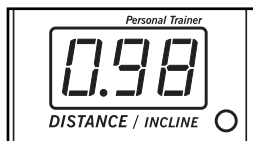

CALORIES/FAT CALORIES display

—This display shows the numbers of calories and fat calories you have burned. (See page 19.)

Every seven seconds, the display will change from one number to the other. The FAT CALS. indicator will light when the number of fat calories is shown.



PULSE display

—This display shows your heart rate when the hand pulse sensor or the optional chest pulse sensor is used (see HOW TO USE THE HAND PULSE SENSOR on page 6). If the optional chest pulse sensor is worn, the CHEST PULSE indicator will light.

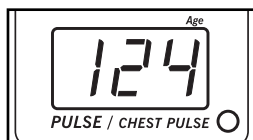

8 When you are finished exercising, stop the walking belt and remove the key.

Step onto the foot rails and press the PAUSE/STOP button. Next, change the incline of the treadmill to 2%. **The incline must be at 2% when the treadmill is folded to the storage position, or the treadmill will be damaged.** Remove the key from the console and put it in a secure place. Move the on/off switch to the "off" position (see page 9).

HOW TO USE THE INCLINE PROGRAM AND THE SPEED PROGRAMS

The Incline 1 program automatically controls the incline of the treadmill as it guides you through an effective workout; the Speed 1, Speed 2, and Speed 3 programs automatically control the speed of the treadmill. The program profiles printed on the console show how the incline or speed will change during each program. (Note: If the optional chest pulse sensor is used, the Speed 2 and Speed 3 programs become pulse programs—refer to the instructions accompanying the chest pulse sensor.) Follow the steps below to use the Incline program or a Speed program.

1 Insert the key fully into the console.

See HOW TO TURN ON THE POWER on page 9.

2 Select the desired program.

To select a program, the **MANUAL indicator or a program indicator must be flashing.** If necessary, hold down the PAUSE/STOP button for two seconds until the MANUAL indicator is flashing. **Next, press the SELECT + or – button repeatedly until the Incline 1, Speed 1, Speed 2, or Speed 3 program indicator is flashing.** Then, press the ENTER button.

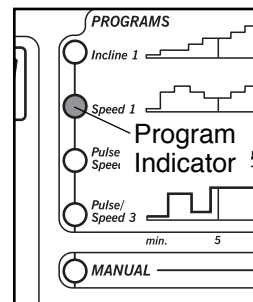

Note: When you are familiar with the console, you may go directly to step 6. While learning to use the console, please read all steps.

3 Enter your weight if desired.

When a program is selected, a weight setting will begin to flash in the CALORIES/FAT CALORIES display. If your weight is entered into the console, the CALORIES/FAT CALORIES display will be more accurate.



If you do not want to enter your weight, or if you have already entered your weight, press the ENTER button. If you want to enter your weight, press the SELECT buttons. When the correct weight is shown, press the ENTER button.

4 Enter your age if desired.

See step 4 on page 10.

5 Adjust the maximum incline or speed setting.

If you selected the Incline 1 program: After an age setting is entered, a number will begin to flash in the DISTANCE/ INCLINE display. This number shows the maximum incline that the treadmill will reach during the program. The maximum incline setting can be from 5% to 10%. If you want to adjust the maximum incline setting, press the SELECT buttons. Then, press the ENTER button.

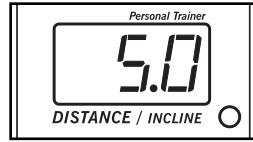

If you selected the Speed 1, Speed 2, or Speed 3 program: After an age setting is entered, a number will begin to flash in the SPEED display. This number shows the maximum speed that the walking belt will reach during the program. The maximum speed setting can be from 4 mph to 10 mph. If you want to change the maximum speed setting, press the SELECT buttons. Then, press the ENTER button.

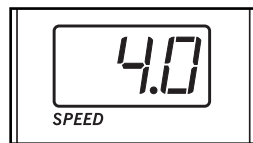

6 Press the START button or the SPEED + button

If you selected the Incline 1 program: A moment after the START button or the SPEED + button is pressed, the walking belt will begin to move and the treadmill will adjust to the first incline setting of the program (unless it is already at the first incline setting). Hold the handrails and begin walking. During the program, the incline of the treadmill will periodically change as shown by the program profile on the console. The speed of the walking belt can be changed as desired during the program with the SPEED buttons.

The TIME display will show the time remaining in the program. When no time remains, the walking belt will slow to a stop and the program will be completed.

Note: If the program is too easy or too difficult, the

current incline setting can be adjusted with the INCLINE buttons. To stop the program for a moment, press the PAUSE/STOP button. The displays will pause and the TIME display will begin to flash. To restart the program, press the START button or the SPEED + button. To end the program at any time, hold down the PAUSE/STOP button for two seconds. The console will then be in the same state as if the key had just been inserted.

If you selected the Speed 1, Speed 2, or Speed 3 program: A moment after the START button or the SPEED + button is pressed, the walking belt will begin to move. Hold the handrails and begin walking. During the program, the speed of the walking belt will periodically change as shown by the program profile on the console. The incline of the treadmill can be changed as desired during the program with the INCLINE buttons.

The TIME display will show the time remaining in the program. When no time remains, the walking belt will slow to a stop and the program will be completed.

Note: If the program is too easy or too difficult, the current speed setting can be adjusted with the SPEED buttons. To stop the program for a moment, press the PAUSE/STOP button. The displays will pause and the TIME display will begin to flash. To restart the program, press the START button or the SPEED + button. To end the program at any time, hold down the PAUSE/STOP button for two seconds. The console will then be in the same state as if the key had just been inserted.

7 Follow your progress with the LED displays.

See step 7 on page 10.

8 When you are finished exercising, remove the key.

Make sure that the incline of the treadmill is at 2%. **The incline must be at 2% when the treadmill is folded to the storage position, or the treadmill will be damaged.** Remove the key from the console and put it in a safe place. In addition, move the on/off switch to the "off" position (see page 9).

HOW TO PROGRAM THE LEARN 1 AND LEARN 2 PROGRAMS

The Learn 1 and Learn 2 programs are workout programs that you create. The programs control both the speed and the incline of the treadmill, and can be up to 40 minutes long. The programs are stored in memory, and can be changed as many times as desired. Follow the steps below to use one of these programs.

1 Insert the key fully into the console.

See HOW TO TURN ON THE POWER on page 9.

2 Select the Learn 1 or Learn 2 program.

To select the Learn 1 or Learn 2 program, the **MANUAL** indicator or a program indicator must be flashing. If necessary, hold down the

PAUSE/STOP button for two seconds until the MANUAL indicator is flashing. **Next, press the SELECT + or – button** repeatedly until the Learn 1 or Learn 2 program indicator is flashing. Then, press the ENTER button.

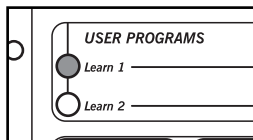

Note: When you are familiar with the console, you may go directly to step 5. While learning to use the console, please read all steps.

3 Enter your weight if desired.

When the Learn 1 or Learn 2 program is selected, a weight setting will begin to flash in the CALORIES/FAT CALORIES display. If your weight is entered into the console, the CALORIES/FAT CALORIES display will be more accurate.



If you do not want to enter your weight, or if you have already entered your weight, press the ENTER button. If you want to enter your weight, press the SELECT buttons. When the correct weight is shown, press the ENTER button.

4 Enter your age if desired.

See step 4 on page 10.

5 Press the START button or the SPEED + button.

A moment after the button is pressed, the walking belt will begin to move. Hold the handrails and begin walking.

6 Press the LEARN button and program the desired speed and incline settings.

When the LEARN button is pressed, the Learn 1 or Learn 2 indicator will begin to flash rapidly. **Speed and incline settings can be programmed only when the indicator is flashing rapidly.**

Each program is divided into one-minute periods. One speed setting and one incline setting can be programmed for each period. To program speed and incline settings for the first period, simply adjust the speed and incline of the treadmill as desired with the SPEED and INCLINE buttons. When the first one-minute period is completed, two tones will sound and the current speed and incline settings will be stored in memory. Program speed and incline settings for the second one-minute period in the same way. Repeat this procedure until you have programmed speed and incline settings for as many one-minute periods as desired. Programs can have up to forty periods.

Note: To stop the program for a moment, press the PAUSE/STOP button. The displays will pause and the TIME display will begin to flash. To restart the program, press the START button or the SPEED + button.

7 Hold down the PAUSE/STOP button for two seconds.

When you have programmed speed and incline settings for as many one-minute periods as desired, hold down the PAUSE/STOP button for two seconds. The speed and incline settings that you have programmed and the length of the program will be stored in memory. To use the program again, see HOW TO USE THE LEARN 1 AND LEARN 2 PROGRAMS on page 14.

8 When the program is completed, remove the key.

Make sure that the incline of the treadmill is at 2%. **The incline must be at 2% when the treadmill is folded to the storage position, or the treadmill will be damaged.** Remove the key from the console and put it in a safe place. In addition, move the on/off switch to the "off" position (see page 9).

HOW TO USE THE LEARN 1 AND LEARN 2 PROGRAMS

1 Insert the key fully into the console.

See HOW TO TURN ON THE POWER on page 9.

2 Select the Learn 1 or Learn 2 program.

To select the Learn 1 or Learn 2 program, the **MANUAL** indicator or a program indicator must be flashing. If neces-

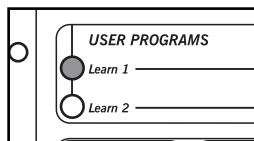

sary, hold down the PAUSE/STOP button for two seconds until the MANUAL indicator is flashing. **Next, press the SELECT + or - button** repeatedly until the Learn 1 or Learn 2 program indicator is flashing. Then, press the ENTER button.

Note: When you are familiar with the console, you may go directly to step 5. While learning to use the console, please read all steps.

3 Enter your weight if desired.

When the Learn 1 or Learn 2 program is selected, a weight setting will begin to flash in the CALORIES/FAT CALORIES display. If your weight is entered into the console, the CALORIES/FAT CALORIES display will be more accurate.



If you do not want to enter your weight, or if you have already entered your weight, press the ENTER button. If you want to enter your weight, press the SELECT buttons. When the correct weight is shown, press the ENTER button.

4 Enter your age if desired.

See step 4 on page 10.

5 Press the START button.

A moment after the button is pressed, the walking belt will begin to move. Hold the handrails and begin walking.

During the first one-minute period of the program, the speed and incline of the treadmill will automatically adjust to the first settings that you programmed previously. When the first one-minute period is completed, two tones will sound and the speed and incline of the treadmill will automatically adjust to the second settings that you programmed. The program will continue in this manner until no time remains in the TIME display. The walking belt will then slow to a stop and the program will be completed.

Note: To stop the program for a moment, press the PAUSE/STOP button. The displays will pause and the TIME display will begin to flash. To restart the program, press the START button or the SPEED + button. To end the program at any time, hold down the PAUSE/STOP button for two seconds. The console will then be in the same state as if the key had just been inserted.

Note: While the program is running, the speed and incline of the treadmill can be adjusted with the SPEED and INCLINE buttons. Adjustments will not be stored in memory. To **reprogram** speed and incline settings, press the LEARN button. The Learn 1 or Learn 2 indicator will begin to flash rapidly. **Speed and incline settings can be reprogrammed only when the indicator is flashing rapidly.** Next, adjust the speed and incline of the treadmill with the SPEED and INCLINE buttons. When the current one-minute period of the program is completed, the new speed and incline settings will be stored in memory. When you have reprogrammed speed and incline settings for as many one-minute periods as desired, press the LEARN button again.

6 Follow your progress with the five displays.

Refer to step 7 on page 10.

7 When the program is completed, remove the key.

Make sure that the incline of the treadmill is at 2%. **The incline must be at 2% when the treadmill is folded to the storage position, or the treadmill will be damaged.** Remove the key from the console and put it in a safe place. In addition, move the on/off switch to the "off" position (see page 9).

THE INFORMATION MODE

The console features an information mode that keeps track of the total time and distance accumulated on the treadmill. The information mode also allows you to switch the console from miles per hour to kilometers per hour.

To select the information mode, hold down the PAUSE/STOP button while inserting the key into the console. When the information mode is selected, the following information will be shown:

The TIME display will show the total number of hours accumulated on the treadmill.



The SPEED display will show an "E" (for english miles) or an "M" (for metric kilometers).
Note: To change the unit of measurement, press the SPEED + button.

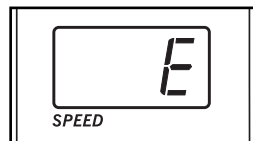

The DISTANCE/INCLINE display will show the total number of miles accumulated on the treadmill.

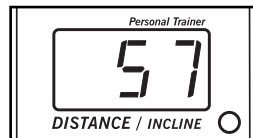

To exit the information mode, remove the key from the console.

THE OPTIONAL PULSE KIT

An optional chest pulse sensor can be worn during your workouts, for hands-free heart rate monitoring. **To purchase the chest pulse sensor, please call toll-free 1-800-201-2172.**

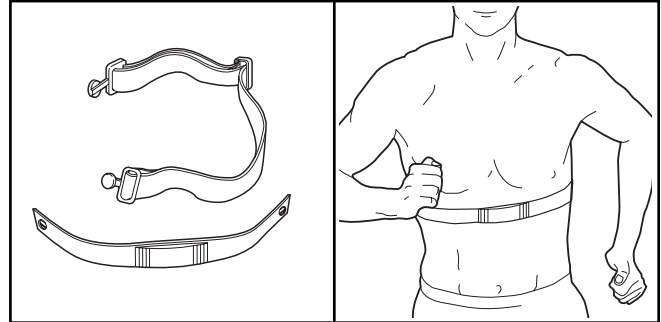

Note: The hand pulse sensor and the chest pulse sensor cannot be used simultaneously.

HOW TO FOLD AND MOVE THE TREADMILL

HOW TO FOLD THE TREADMILL FOR STORAGE

Before folding the treadmill, adjust the incline to the lowest position. If this is not done, the treadmill may be permanently damaged. Next, unplug the power cord. **Caution: You must be able to safely lift 45 pounds (20 kg) in order to raise, lower, or move the treadmill.**

1. Hold the treadmill in the locations shown at the right. **To decrease the possibility of injury, bend your legs and keep your back straight. As you raise the treadmill, make sure to lift with your legs rather than your back.** Raise the treadmill about halfway to the vertical position.

2. Move your right hand to the position shown, and hold the treadmill firmly. Using your left hand, push the storage latch to the left. Raise the treadmill until the storage latch snaps into the catch. **Make sure that the storage latch is inside of the catch.**

To protect the floor or carpet from damage, place a mat under the treadmill. Keep the treadmill out of direct sunlight. Do not leave the treadmill in the storage position in temperatures above 85° Fahrenheit.

HOW TO MOVE THE TREADMILL

Before moving the treadmill, convert the treadmill to the storage position as described above. **Make sure that the storage latch is inside of the catch.**

1. Hold the handrails and place one foot on the base.
2. Tilt the treadmill back until it rolls freely on the front wheels. Carefully move the treadmill to the desired location. **To reduce the risk of injury, use extreme caution while moving the treadmill. Do not attempt to move the treadmill over an uneven surface.**
3. Place one foot on the base, and carefully lower the treadmill until it is resting in the storage position.

HOW TO LOWER THE TREADMILL FOR USE

1. Hold the upper end of the treadmill with your right hand as shown. Using your left hand, push the storage latch to the left. Pivot the treadmill until the storage latch is past the catch.
2. See the drawing at the top of this page. Hold the treadmill firmly with both hands, and lower the treadmill to the floor. **To decrease the possibility of injury, bend your legs and keep your back straight.**

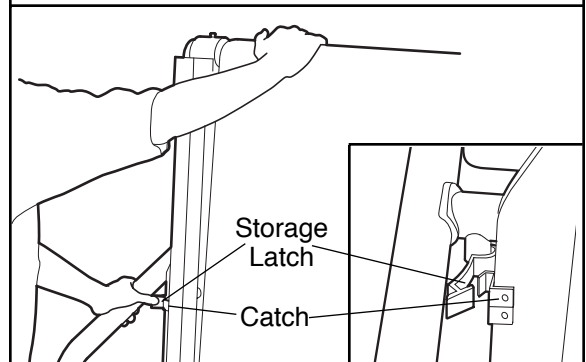
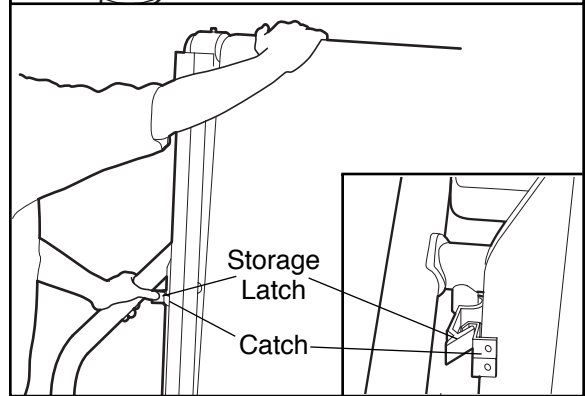
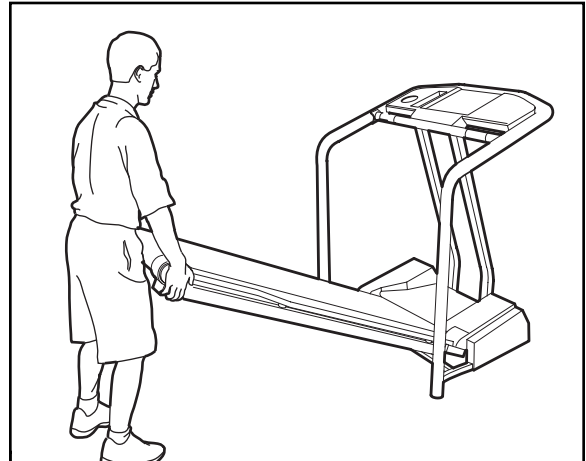

TROUBLE-SHOOTING AND MAINTENANCE

Most treadmill problems can be solved by following the simple steps below. If further assistance is needed, call our toll-free HELPLINE at 1-800-736-6879, Monday through Saturday, 7 a.m. until 7 p.m. Central Time (excluding holidays).

PROBLEM

SOLUTION

1. The power does not turn on

a. Make sure that the power cord is plugged into a surge suppressor, and that the surge suppressor is plugged into a properly grounded outlet (see page 7). Use only a single-outlet surge suppressor that is UL 1449 listed as a transient voltage surge suppressor (TVSS). The surge suppressor must have a UL suppressed voltage rating of 400 volts or less and a minimum surge dissipation of 450 joules. The surge suppressor must be electrically rated for 120 volts AC and 15 amps.

b. Make sure that the key is fully inserted into the console.

c. Check the circuit breaker located on the frame near the power cord. If the switch protrudes as shown, the circuit breaker has tripped. To reset the circuit breaker, wait for five minutes and then press the switch back in.

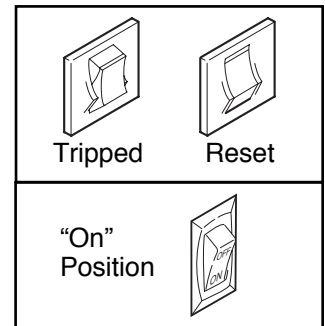

d. Check the on/off switch located on the frame near the power cord. The switch must be in the “on” position.

2. The power turns off during use

a. Check the circuit breaker (see c. above). If the circuit breaker has tripped, wait for five minutes and then press the switch back in.

b. Make sure that the power cord is plugged in.

c. Remove the key from the console and then reinsert it.

d. Make sure that the on/off switch is in the “on” position (see d. above).

3. The walking belt slows when walked on

a. Use only a single-outlet surge suppressor that is UL 1449 listed as a transient voltage surge suppressor (TVSS). The surge suppressor must have a UL suppressed voltage rating of 400 volts or less and a minimum surge dissipation of 450 joules. The surge suppressor must be electrically rated for 120 volts AC and 15 amps.

b. If the walking belt is overtightened, treadmill performance may decrease and the walking belt may be permanently damaged. Remove the key and **UNPLUG THE POWER CORD**. Using the included allen wrench, turn both rear roller adjustment bolts counterclockwise 1/4 of a turn. When the walking belt is properly tightened, you should be able to lift **the edges** of the walking belt 3 to 4 inches off the walking platform. Be careful to keep the walking belt centered. Plug in the power cord, insert the key and run the treadmill for a few minutes. Repeat until the walking belt is properly tightened.

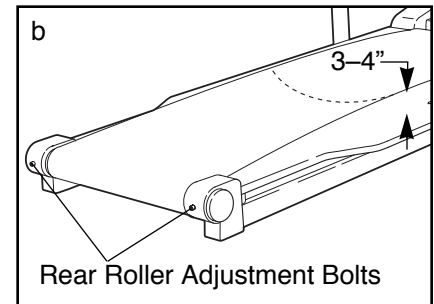

PROBLEM**SOLUTION****4. The walking belt is off-center or slips when walked on**

- a. If the walking belt has shifted to the left, first remove the key and **UNPLUG THE POWER CORD**. Using the allen wrench, turn the left rear roller adjustment bolt clockwise, and the right bolt counterclockwise, 1/4 of a turn each. Be careful not to overtighten the walking belt. Plug in the power cord, insert the key and run the treadmill for a few minutes. Repeat until the walking belt is centered.

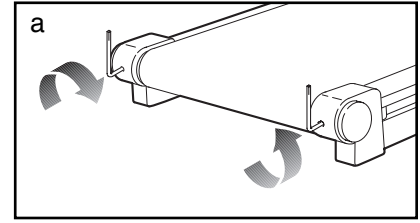

- b. If the walking belt has shifted to the right, first remove the key and **UNPLUG THE POWER CORD**. Using the allen wrench, turn the left rear roller adjustment bolt counterclockwise, and the right bolt clockwise, 1/4 of a turn each. Be careful not to overtighten the walking belt. Plug in the power cord, insert the key and run the treadmill for a few minutes. Repeat until the walking belt is centered.

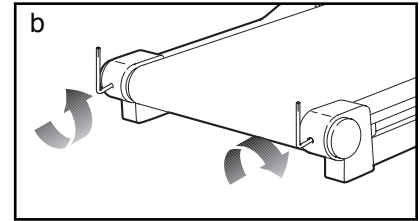

- c. If the walking belt slips when walked on, first remove the key and **UNPLUG THE POWER CORD**. Using the allen wrench, turn both rear roller adjustment bolts clockwise, 1/4 of a turn. When the walking belt is correctly tightened, you should be able to lift the **edges** of the walking belt 3 to 4 inches off the walking platform. Be careful to keep the walking belt centered. Plug in the power cord, insert the key and run the treadmill for a few minutes. Repeat until the walking belt is properly tightened.

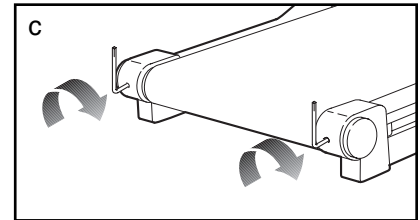
**5. An error code (“E1,” “E2,” “E3,” or “E4,”) appears in the SPEED display**

- a. If error code “E1,” “E2,” or “E3” appears in the SPEED display, remove the key, wait for ten seconds, and then reinsert it. If the error code appears again, call our Customer Service Department. **Do not operate the treadmill until the problem is corrected.**
- b. Error code “E4” may appear in the SPEED display if the walking belt is moving at a slow speed and there is excessive stress on the motor. If this occurs, remove the key, wait for ten seconds, and then reinsert it. If you weight over 200 pounds, it may also be helpful to increase the incline of the treadmill. If the error code appears again, call our Customer Service Department. **Do not operate the treadmill until the problem is corrected.**

6. The walking belt becomes soiled

- a. Use a color-fast upholstery cleaner to clean the walking belt. Test the cleaner on a small area before cleaning the entire belt.

7. Bubbles form in the walking belt

- a. Due to variations in humidity and temperature, there is a possibility that bubbles may form in the walking belt. Although the bubbles will disappear with time, you may unplug the power cord, carefully insert a needle into the bubbles, and push the air out of the bubbles.

CONDITIONING GUIDELINES

⚠ WARNING: Before beginning this or any exercise program, consult your physician. This is especially important for individuals over the age of 35 or individuals with pre-existing health problems.

The hand pulse sensor is not a medical device. Various factors, including the user's movement, may affect the accuracy of heart rate readings. The hand pulse sensor is intended only as an exercise aid in determining heart rate trends in general.

The following guidelines will help you to plan your exercise program. For more information about exercise, consult your physician or obtain a reputable book.

EXERCISE INTENSITY

Whether you want to burn fat or to strengthen your cardiovascular system, you can tailor your exercise to your specific goals. The key to achieving the desired results is to exercise with the proper intensity. As you exercise, your heart rate should be kept at a level between 70% and 85% of your maximum possible heart rate. This is known as your training zone. You can find your training zone in the table below. Training zones are listed according to age and physical condition.

AGE	TRAINING ZONE (Beats/Min.)	
	Unconditioned	Conditioned
20	138-167	133-162
25	136-166	132-160
30	135-164	130-158
35	134-162	129-156
40	132-161	127-155
45	131-159	125-153
50	129-156	124-150
55	127-155	122-149
60	126-153	121-147
65	125-151	119-145
70	123-150	118-144
75	122-147	117-142
80	120-146	115-140

To measure your heart rate during your workouts, use the hand pulse sensor or the optional chest pulse sensor (see page 5).

Burning Fat

To burn fat effectively, you must exercise at a relatively low intensity level for a sustained period of time. During the first few minutes of exercise, your body uses easily accessible carbohydrate calories for energy. Only after the first few minutes of exercise does your body begin to use stored fat calories for energy. If your goal is to burn fat, keep your heart rate near the low end of your training zone as you exercise.

Aerobic Exercise

If your goal is to strengthen your cardiovascular system, your exercise must be “aerobic.” Aerobic exercise is activity that requires large amounts of oxygen for prolonged periods of time. This increases the demand on the heart to pump blood to the muscles, and on the lungs to oxygenate the blood. For aerobic exercise, keep your heart rate near the middle of your training zone as you exercise.

WORKOUT GUIDELINES

Each workout should include three parts: (1) a warm-up, (2) training zone exercise, and (3) a cool-down.

Warming Up—Begin each workout with five to ten minutes of stretching and light exercise to warm up. A proper warm-up increases your body temperature, heart rate, and circulation in preparation for exercise.

Training Zone Exercise—After warming up, increase the intensity of your exercise until your heart rate is in your training zone for 20 to 30 minutes. Breathe regularly and deeply as you exercise—never hold your breath.

Cooling Down—End each workout with five to ten minutes of stretching to cool down. This will develop muscle flexibility and will help to prevent post-exercise problems.

Exercise Frequency

To maintain or improve your condition, complete three workouts each week, with at least one day of rest between workouts. After a few months, you may complete up to five workouts each week if desired. The key to success is to make exercise a regular and enjoyable part of your everyday life.

PART LIST—Model No. 831.297871

R0199A

Key No.	Qty.	Description	Key No.	Qty.	Description	Key No.	Qty.	Description
1	1	Rear Roller	51	1	Power Supply	101	6	Wheel Washer
2	2	Center Isolator	52	1	Controller	102	1	Electronics Cover
3	2	Front Platform Screw	53	1	Power Cord Grommet	103	2	Roller Guard
4	4	Isolator	54	1	Power Cord	104	8	Console Screw
5	1	Left Platform Cushion	55	1	Pulse Sensor Housing	105	1	Catch Nut
6	1	Walking Platform	56	2	Sensor Housing (short)	106	3	Caution Decal
7	3	Frame Pivot Bolt	57	4	Hand Pulse Sensor	107	1	Optic Switch Washer
8	38	Screw	58	1	Pulse Sensor Cap	#	1	8" Black Wire, M/F
9	2	Rear Platform Screw	59	1	Console Base	#	1	4" Black Wire, 2 F
10	5	Power Bracket Screw	60	1	Console	#	1	20" White Wire, 2 F
11	6	Small Screw	61	1	Electronics Bracket	#	1	4" White Wire, M/F
12	2	Hood Bracket Screw	62	2	Latch Screw	#	1	14" Blue Wire, M/F
13	5	8" Cable Tie	63	2	25" Hand Pulse Wire	#	1	4" Blue Wire, 2 F
14	1	Belly Pan	64	1	Key/Clip	#	1	8" Red Wire, M/F
15	1	Hood	65	1	Storage Latch	#	1	4" Green F/Ring
16	2	Frame Pivot Spacer	66	1	Rear Roller Ground Wire	#	1	User's Manual
17	2	Platform Nut	67	2	Incline Warning Decal			
18	1	Right Platform Cushion	68	1	Storage Catch			
19	1	Incline Leg	69	1	Incline Motor Spacer			
20	1	Shock	70	1	Sensor Housing			
21	1	Front Roller/Pulley	71	1	Wrench Clip			
22	1	Walking Belt	72	1	Allen Wrench			
23	1	Motor Tension Nut	73*	1	Optional Pulse Kit			
24	1	Motor Star Washer	74	2	Upright Base Endcap			
25	1	Motor Tension Washer	75	2	Frame Pivot Washer			
26	4	Motor Tension Bolt	76	4	Incline Nut			
27	1	Motor	77	2	Front Wheel			
28	1	Motor Belt	78	2	Wheel Bolt			
29	1	Pulley/Flywheel/Fan	79	6	Base Pad			
30	5	Motor Pivot Nut/Wheel Nut	80	1	Catch Screw			
31	1	Front Roller Adjust. Bolt	81	1	Wire Harness			
32	3	Roller Adjust. Washer	82	1	Upright/Base			
33	1	Motor Pivot Bolt	83	1	Incline Motor Plate			
34	1	Front Roller Adjust. Nut	84	1	Incline Motor Shield			
35	1	Speed Optic Disk	85	1	4" Cable Tie			
36	1	Optic Switch Bracket	86	1	Incline Optic Disk			
37	2	Optic Switch Bolt	87	1	23" Cable Tie			
38	1	Bracket Nut	88	1	Incline Motor			
39	2	Optic Switch	89	8	Belly Pan Screw			
40	1	Optic Switch Star Washer	90	1	Sensor Housing Shim			
41	2	Optic Switch Nut	91	2	Photo Switch Wire			
42	2	Hood Mount	92	1	Frame			
43	3	Grommet	93	1	Right Endcap			
44	4	Plastic Stand-Off	94	1	Left Endcap			
45	1	Power Cord Bracket	95	2	Endcap Pad			
46	1	On/Off Switch	96	1	Motor-Controller Wire			
47	1	Circuit Breaker	97	2	Rear Roller Adjust. Bolt			
48	2	Handrail Endcap	98	1	Latch Decal			
49*	1	Motor/Pulley/Fly./Fan	99	2	Mid Platform Screw			
50	2	Hood Bracket (long)	100	1	Electronics Shield			

* Includes all parts shown in the box.
 For more information about the optional pulse kit, see page 15.
 # These parts are not illustrated

Specifications are subject to change without notice.

EXPLODED DRAWING — Model No. 831.297871

R0199A

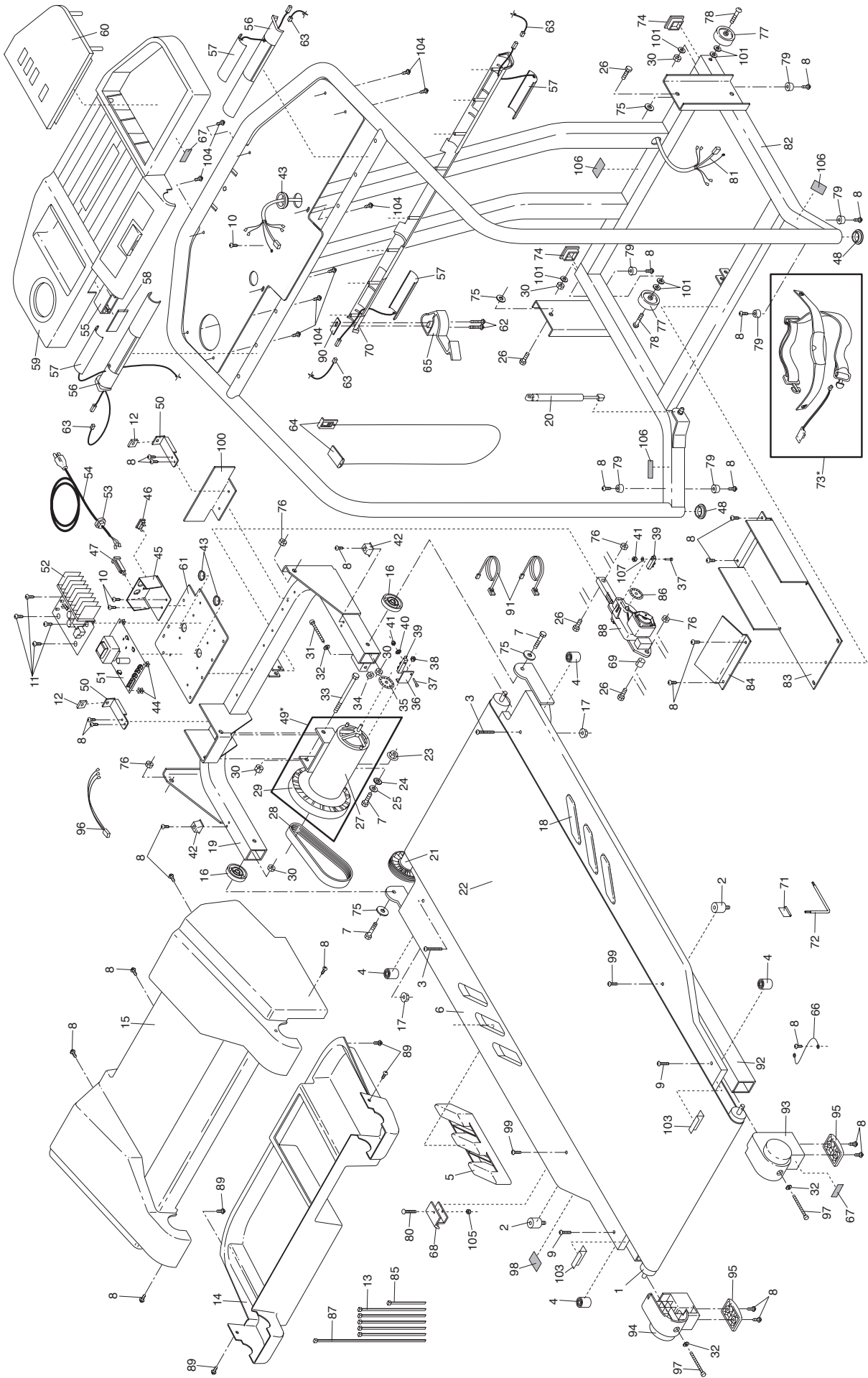



Model No. 831.297871

QUESTIONS?

If you find that:

- you need help assembling or operating the HealthRider® SOFTSTRIDER EX
- a part is missing
- you need to schedule repair service

call our toll-free HELPLINE

1-800-736-6879

Monday–Saturday, 7 am–7 pm
Central Time (excluding holidays)

REPLACEMENT PARTS

If parts become worn and need to be replaced, call the following toll-free number

**1-800-FON-PART
(1-800-366-7278)**

The model number and serial number of your HealthRider® SOFTSTRIDER EX treadmill are listed on a decal attached to the treadmill. See the front cover of this manual to find the location of the decal.

All replacement parts are available for immediate purchase or special order when you visit your nearest SEARS Service Center. To request service or to order parts by telephone, call the toll-free numbers listed at the left.

When requesting help or service, or ordering parts, please be prepared to provide the following information:

- The NAME OF THE PRODUCT (HealthRider® SOFTSTRIDER EX™ treadmill)
- The MODEL NUMBER OF THE PRODUCT (831.297871)
- The KEY NUMBER AND DESCRIPTION OF THE PART (see the EXPLODED DRAWING and PART LIST included in this manual)

FULL 90 DAY WARRANTY

For 90 days from the date of purchase, if failure occurs due to defect in material or workmanship in this SEARS TREADMILL EXERCISER, contact the nearest SEARS Service Center throughout the United States and SEARS will repair or replace the TREADMILL EXERCISER, free of charge.

This warranty does not apply when the TREADMILL EXERCISER is used commercially or for rental purposes.

This warranty gives you specific legal rights, and you may also have other rights which vary from state to state.

SEARS, ROEBUCK AND CO., DEPT. 817WA, HOFFMAN ESTATES, IL 60179