

Instruction Manual  
ETC00303  
02/2007

# Instruction Manual

## BINOS<sup>®</sup> E

### Economic & Enhanced Gas Analyzer

3<sup>rd</sup> Edition 02/2007



**ROSEMOUNT<sup>®</sup>**  
Analytical

[www.EmersonProcess.com](http://www.EmersonProcess.com)



**EMERSON<sup>™</sup>**  
Process Management

## ESSENTIAL INSTRUCTIONS

### READ THIS PAGE BEFORE PROCEEDING!

Emerson Process Management (Rosemount Analytical) designs, manufactures and tests its products to meet many national and international standards. Because these instruments are sophisticated technical products, you **MUST properly install, use, and maintain them** to ensure they continue to operate within their normal specifications. The following instructions **MUST be adhered to** and integrated into your safety program when installing, using and maintaining Emerson Process Management (Rosemount Analytical) products. Failure to follow the proper instructions may cause any one of the following situations to occur: Loss of life; personal injury; property damage; damage to this instrument; and warranty invalidation.

- **Read all instructions** prior to installing, operating, and servicing the product.
- If you do not understand any of the instructions, **contact your Emerson Process Management (Rosemount Analytical) representative** for clarification.
- **Follow all warnings, cautions, and instructions** marked on and supplied with the product.
- **Inform and educate your personnel in the proper installation, operation, and maintenance of the product.**
- **Install your equipment as specified in the Installation Instructions of the appropriate Instruction Manual and per applicable local and national codes.** Connect all products to the proper electrical and pressure sources.
- To ensure proper performance, **use qualified personnel** to install, operate, update, program, and maintain the product.
- When replacement parts are required, ensure that qualified people use replacement parts specified by Emerson Process Management (Rosemount Analytical). Unauthorized parts and procedures can affect the product's performance, place the safe operation of your process at risk, **and VOID YOUR WARRANTY.** Look-alike substitutions may result in fire, electrical hazards, or improper operation.
- **Ensure that all equipment doors are closed and protective covers are in place, except when maintenance is being performed by qualified persons, to prevent electrical shock and personal injury.**

The information contained in this document is subject to change without notice. Misprints reserved.

1<sup>st</sup> Edition 11/2000      2<sup>nd</sup> Edition 05/2001

3rd Edition 02/2007

© 2000-2007 by Emerson Process Management

**Emerson Process Management**  
**GmbH & Co. OHG**  
Industriestrasse 1  
D-63594 Hasselroth  
Germany  
T +49 (0) 6055 884-0  
F +49 (0) 6055 884-209  
Internet: [www.EmersonProcess.com](http://www.EmersonProcess.com)



# Table of Contents

<b><u>SAFETY SUMMARY</u></b>	S - 1
General	S - 2
Gases and Gas Conditioning (Sample Handling)	S - 4
Supply Voltage	S - 4
BINOS E specific notes for the user	S - 5
Additional notes for service / maintenance	S - 6
Electrostatic Discharge	S - 7
<b><u>PREFACE</u></b>	P - 1
<b><u>DESCRIPTION</u></b>	
<b>1. Technical Description</b>	1 - 1
1.1 Front Panel	1 - 1
1.2 Rear Panel	1 - 4
1.3 Internal Construction (Component Layout)	1 - 5
1.3.1 Internal Gas Paths	1 - 7
1.3.2 Printed Circuit Boards	1 - 9
<b>2. Measuring Principle</b>	2 - 1
2.1 NDIR Measurement	2 - 1
2.1.1 Opto - Pneumatic Measuring Principle	2 - 3
2.1.2 Interference Filter Correlation (IFC Principle)	2 - 4
2.2 NDUV Measurement	2 - 6
2.3 Oxygen Measurement	2 - 7
2.3.1 Paramagnetic Measurement	2 - 7
2.3.2 Electrochemical Measurement	2 - 9
2.4 (Vacant)	2 - 11
<b>3. (vacant)</b>	
<b>4. (vacant)</b>	

**OPERATION (STARTUP)**

<b>5.</b>	<b>Installation and Preparation of Startup</b>	5 - 1
5.1	Installation Site	5 - 2
5.2	(vacant)	5 - 3
5.2.1	Pressure Sensor (Option)	5 - 4
5.2.4	Gas Flow	5 - 4
5.3	Gas Connections	5 - 5
<b>6.</b>	<b>Startup Procedure (Switching On)</b>	6 - 1
6.1	Supply Voltage	6 - 2
<b>7.</b>	<b>Measurement / Calibration / Switching (Shut) Off</b>	7 - 1
7.1	Measurement	7 - 1
7.2	Calibration	7 - 2
7.2.1	Calibration (Test) Gases	7 - 2
7.3	Switching (Shut) Off	7 - 4
<b>8.</b>	<b>BINOS E Front Panel Program</b>	8 - 1
8.1	Requirements	8 - 1
8.2	Installation and Startup	8 - 2
8.2.1	Installation	8 - 2
8.2.2	Startup	8 - 4
8.3	Function Keys	8 - 4
8.4	Status Display ("Status")	8 - 10
8.5	Display Page	8 - 11
8.6	Recorder Page	8 - 14
8.6.1	Averaging	8 - 15
8.6.2	Spooling	8 - 15
8.6.3	Recording	8 - 15
8.7	Messages Page	8 - 16
8.8	Analog Output Link and Adjustment Page	8 - 18
<b>9.</b>	<b>BINOS E Data Exchange</b>	9 - 1

<b>10.</b>	<b><u>TROUBLESHOOTING</u></b>	
10.1	(vacant)	
<b>11.</b>	<b>Test Procedure / Test Points (vacant)</b>	
<b>12.</b>	<b>Removal / Replacement of Components (vacant)</b>	
<b>13.</b>	<b><u>MAINTENANCE</u></b>	13 - 1
<b>14.</b>	<b>Leak Testing</b>	14 - 1
<b>15.</b>	<b>Opening the Housing</b>	15 - 1
15.1	BINOS E (Metal-sheet housing)	15 - 1
15.1.1	Housing Cover	15 - 1
15.2	BINOS E (1/2 19" housing)	15 - 2
15.2.1	Housing Cover	15 - 2
<b>16.</b>	<b>(vacant)</b>	
<b>17.</b>	<b>Replacement and Cleaning of Photometric Components</b>	17 - 1
17.1	Removal of the Photometer Assembly	17 - 1
17.2	Light Source Replacement (IR)	17 - 2
17.3	Cleaning of Analysis Cells and Windows	17 - 3
17.3.1	Removal of Analysis Cells	17 - 3
17.3.2	Cleaning	17 - 4
17.3.3	Reinstalling of Analysis Cells	17 - 5
17.4	Reinstalling of the Photometer Assembly	17 - 6
17.5	Physical Zeroing	17 - 7
<b>18.</b>	<b>Check / Replacement of electrochemical Oxygen Sensor</b>	18 - 1
18.1	Check of the Sensor	18 - 2
18.2	Replacement of the Sensor	18 - 3
18.2.1	Removal of the Sensor	18 - 3
18.2.2	Replacing the Sensor	18 - 4
18.2.3	Reinstalling of the Sensor	18 - 4
18.2.4	Basic conditions for the Oxygen Sensor	18 - 5
<b>19.</b>	<b>Cleaning of Housing Outside</b>	19 - 1

<b>20.</b>	<b><u>TECHNICAL DATA</u></b>	20 - 1
20.1	Housing	20 - 1
20.2	Options	20 - 2
20.3	General Specifications	20 - 2
20.3.1	BINOS E Specifications	20 - 3
20.3.2	Cross Sensitivities	20 - 4
20.3.3	Dimensions	20 - 5
20.4	Voltage supply	20 - 6
20.4.1	Electrical Safety	20 - 6
20.4.2	Power Supply	20 - 6
	 <b><u>SUPPLEMENT</u></b>	
<b>21.</b>	<b>Pin Assignments</b>	21 - 1
21.1	24 V dc Input	21 - 1
21.2	Serial Interfaces (vacant)	21 - 2
21.3	Analog Signal Outputs (vacant)	21 - 2
<b>22.</b>	<b>Calculation of Water Content from Dew-Point to Vol.-% or g/Nm<sup>3</sup></b>	22 - 1

## Safety Summary

Outside and/or inside BINOS E or at operation manual resp. different symbols gives you a hint to special sources of danger.



**Source of danger !**  
See Operation Manual!



**High Voltage !**



**Electrostatic Discharge (ESD) !**



**Explosives !**



**Hot components !**



**Toxic !**



**UV Radiation !**



**Risk to health !**



**BINOS E specific notes for the user !**

In operation manual we will give partly additional informations to these symbols.  
Strictly follow these instructions please !

## **1. General**

- ◆ The following general safety precautions must be observed during all phases of operation, service and repair of this instrument !  
Failure to comply with these precautions or with specific warnings elsewhere in this manual violates safety standards of design, manufacture and intended use of this instrument !  
Failure to comply with these precautions may lead to personal injury and damage to this instrument !
  
- ◆ Fisher-Rosemount GmbH & Co. does not take responsibility (liability) for the customer's failure to comply with these requirements !
  
- ◆ Do not attempt internal service or adjustment unless other person, capable of rendering first aid and resuscitation, is present !
  
- ◆ Because of the danger of introducing additional hazards, do not perform any unauthorized modification to the instrument !  
Return the instrument to a Fisher-Rosemount Sales and Service office for service or repair to ensure that safety features are maintained !
  
- ◆ Instruments which appear damaged or defective should be made inoperative and secured against unintended operation until they can be repaired by qualified service personnel.





Operating personnel must not remove instrument covers !  
Component replacement and internal adjustments must be made by qualified service personnel only !



Read and understand all operation manuals and receiving appropriate training before attempting to operate with the instrument !  
Be sure to observe the additional notes, safety precautions and warnings given in the individual operation manuals !



Do not operate the instrument in the presence of flammable gases or explosive atmosphere without supplementary protective measures !



At photometer or heated components there could be exist hot components !



The optional UV lamp contains mercury. Lamp breakage could result in mercury exposure ! Mercury is highly **toxic** !  
If the lamp is broken, avoid any skin contact to mercury and inhalation of mercury vapors !

## 2. Gases and Gas Conditioning (Sample Handling)



Be sure to observe the safety regulations for the respective gases (sample gas and test gases / span gases) and the gas bottles !



Flammable or explosive gas mixtures must not be purged into the instrument without supplementary protective measures !

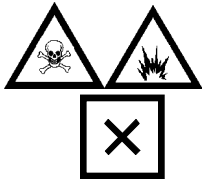

To avoid a danger to the operators by explosive, toxic or unhealthy gas components, first purge the gas lines with ambient air or nitrogen (N<sub>2</sub>) before cleaning or exchange parts of the gas paths.



Pressure of sample gas / test gases max. 1,500 hPa !

## 3. Supply Voltage



The socket outlet shall be installed near the equipment and shall be easily accessible to disconnect the device from the socket outlet.



Verify whether the line voltage stated on the instrument or power supply agrees with that of your mains line!



Be sure to observe the safety precautions and warnings given by manufacturer of power supply !

◆ BINOS E is a Safety Class 2 (  ) instrument.



Verify correct polarity for 24 V dc operation !



Use only power supply UPS 01 T, SL5, SL10 (SL 5/10 for cabinet mounting only) or equivalent power supplies to be in agreement with the CE conformity.

#### 4. BINOS E specific notes for the user



Before startup **unscrew** transfer **safety lock** (knurled-head screws) of the BINOS E (Item 5. of operation manual) !

The installation site for the instrument has to be **dry** and remain **above freezing point** at all times.



The instrument must be exposed neither to direct sunlight nor to strong sources of heat. Be sure to observe the permissible ambient temperature !  
 For outdoor sites, we recommend to install the instrument in a protective cabinet. At least, the instrument has to be protected against rain (e.g., shelter).



Free flow of air into and out of the BINOS E (ventilation slits) must not be hindered by nearby objects or walls !



Do not interchange gas inlets and gas outlets !  
 All gases have to be supplied to the BINOS E as conditioned gases !  
 When the instrument is used with corrosive gases, it is to be verified that there are no gas components which may damage the gas path components.



The exhaust gas lines have to be mounted in a declining, descending, pressureless and frost-free and according to the valid emission legislation !



In case it is necessary to open the gas paths, close the analyzers gas connections with PVC caps immediatly !



Pressure of sample gas / test gases max. 1,500 hPa !



By using of optional delivering terminal strip adapters with BINOS E the analyzer is not be in agreement with the CE conformity. In this case CE conformity has to be declared by customer as "manufacturer of system".

Use only optional delivered cables from our factory or equivalent shielded cables to be in agreement with CE conformity.



The customer has to prove that the shield is connected on both sides. Shield and connectors housing has to be connected conductive. Sub.-min.-D-plugs/sockets have to be screwed to the analyzer.

## 5. Additional notes for service / maintenance



Operating personnel must not remove instrument covers !  
Component replacement and internal adjustments must be made by qualified service personnel only !



Always disconnect power, discharge circuits and remove external voltage sources before troubleshooting, repair or replacement of any component !



Any work inside the instrument without switching off the power must be performed by a specialist, who is familiar with the related danger, only !

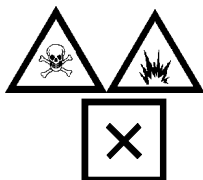

To avoid a danger to the operators by explosive, toxic or unhealthy gas components, first purge the gas lines with ambient air or nitrogen (N<sub>2</sub>) before cleaning or exchange parts of the gas paths.



At photometer or heated components there could be exist hot components !



In case of exchanging fuses the customer has to be certain that fuses of specified type and rated current are used. It is prohibited to use repaired fuses or defective fuse holders or to short-circuit fuse carriers (fire hazard).



UV source operates with high voltage !  
[Voltage supply UVS (Fig. 1-3)]



Ultraviolet light from UV lamp can cause permanent eye damage !  
Do not look directly at the ultraviolet source !



At component replacement or installation the RF shielding contacts must not be bended !

## 6 Electrostatic Discharge



The electronic parts of the analyzer can be irreparably damaged if exposed to **electrostatic discharge (ESD)**.

The instrument is ESD protected when the covers have been secured and safety precautions observed. When the housing is open, the internal components are not ESD protected anymore.

Although the electronic parts are reasonable safe to handle, you should be aware of the following considerations:

Best ESD example is when you walked across a carpet and then touched an electrical grounded metal doorknob. The tiny spark which has jumped is the result of electrostatic discharge (ESD).

You prevent ESD by doing the following:

Remove the charge from your body before opening the housing and maintain during work with opened housing, that no electrostatic charge can be built up.

Ideally you are opening the housing and working at an ESD - protecting workstation. Here you can wear a wrist trap.

However, if you do not have such a workstation, be sure to do the following procedure exactly:

Discharge the electric charge from your body. Do this by touching a device that is grounded electrically (any device that has a three - prong plug is grounded electrically when it is plugged into a power receptacle).

This should be done several times during the operation with opened housing (especially after leaving the service site because the movement on a low conducting floors or in the air might cause additional ESDs).



## Preface

The BINOS E analyzers offer multi-component, multi-method analysis. Different measurement methods can be combined in one analyzer.

BINOS E is designed to measure up to max. 4 gas components and up to 8 secondary parameters (pressure, temperature and flow). Primary measurements include photometer and non-photometer-channels (possible combinations: see price matrix):

- Non-dispersive Infrared (up to two channels)
- Non-dispersive Ultraviolet (one channel)
- Paramagnetic Oxygen (up to two channels)
- Electrochemical Oxygen (up to two channels)

BINOS E can combine up to two photometer and up to two non-photometer channels.

BINOS E is designed for OEM customers, for bench and sensor integrators, for universities and institutes. That means for anybody who likes a modern new measuring philosophy with communication via serial interface.

System builders create their own Control Units or Platforms. They need either high performance optical or sensor benches (fast response, low ranges and/or high dynamic measurements) or robust photometer/sensor technologies but with no need for an instrument display. There is also no need for digital inputs or outputs, often even no necessity for analog outputs. That is why BINOS E offers as a standard only communication via serial interface. Analog outputs are available as option. Relay contacts, digital inputs and outputs are not provided.

Main applications for BINOS E are:

- Automotive (Internal Combustion Engine Emissions, ICEE)
- Fast response capnography (Lung function tests)
- Solids Analyzers (C, S, H, N analysis)
- TOC/ TN/ TS Analyzers (Total organic carbon, nitrogen or sulphur)
- Metallurgical Business (Oven atmosphere, hardening, ceramic)

BINOS E is specially designed to measure high dynamic ranges such as low carbon monoxide concentrations for automotive applications combined with other measurements:

CO<sub>low</sub>: 0 - 50 ... 5,000 ppm

CO<sub>high</sub>: 0 - 0.5(1) ... 10 Vol.-%

CO<sub>2</sub>: 0 - 1 ... 16 (20) Vol.-%

O<sub>2</sub>: 0 - 1 (2) ... 10 (25) Vol.-%

An additional NO, SO<sub>2</sub> or C<sub>6</sub>H<sub>14</sub> channels are available as option for automotive applications:

NO: 0 - 250 ... 2,500 ppm  
SO<sub>2</sub>: 0 - 130 ... 3,000 ppm (NDUV)  
C<sub>6</sub>H<sub>14</sub>: 0 - 300 ... 3,000 ppm  
NO<sub>2</sub>: 0 - 250 ... 1,000 ppm (NDUV)

For medical application we offer CO and CH<sub>4</sub> with IFC principles:

CO: 0 - 3,000 ppm  
CH<sub>4</sub>: 0 - 3,000 ppm

Solids analyzers can be equipped with:

CO: 0 - 1 ... 10 Vol.-%  
CO<sub>2</sub>: 0 - 1 ... 16 (20) Vol.-%  
SO<sub>2</sub>: 0 - 1 ... 10 Vol.-%  
H<sub>2</sub>O: 0 - 1 ... 3(4) Vol.-%

For TOC/ TN/ TS applications we can provide:

CO<sub>2</sub>: 0 - 1 ... 16 (20) Vol.-% or 0 - 100 (200) ... 2,000 (3,000) ppm  
NO: 0 - 250 ... 2,500 ppm  
SO<sub>2</sub>: 0 - 130 ... 3,000 ppm (NDUV)

For metallurgical applications we offer:

CO: 0 - 1 ... 20 Vol.-% or 0 - 20 ... 100 Vol.-%  
CO<sub>2</sub>: 0 - 5 ... 100 Vol.-%

This is an overview about main applications with main configurations/components. Other components and applications may be provided on request.

The following list of abbreviations gives an overview about terms used in this manual:

IR = measurement at infrared spectral range  
UV = measurement at ultraviolet spectral range  
VIS = measurement at visual spectral range  
PO<sub>2</sub> = paramagnetic oxygen measurement  
EO<sub>2</sub> = electrochemical oxygen measurement



## 1. Technical Description

BINOS E is different from common gas analyzers as follows:

The BINOS E analyzer is assembled as a blind instrument without need of an operation front panel.

Communication is done via serial interface RS 232 with the Fisher-Rosemount Front Panel Program (option) or via DPS protocol to support a user designed program.

The Front Panel Program is described in chapter 8 while chapter 9 gives information about the DSP protocol.

Compared with NGA 2000 MLT 1 the ACU (analyzer control unit) is missing and the cardcage is modified by replacing the optional PCB's SIO, DIO and LEM (network board) with a new I/O board LIO (low cost I/O). Thus, BINOS E is a stand-alone analyzer without network functionality. The operation procedure is performed by an external PC via serial interface.

All components of a BINOS E analyzer are incorporated into a metal-sheet housing or a 1/2 19" housing.

The 1/2 19" housings are available as rack-mounting or table-top versions.

### 1.1 Front Panel

The front panel of the BINOS E analyzer shows a blind plate instead of an operation front panel. The 1/2 19" housing front panel is shown in Fig. 1-1(rack-mountable version).

The metal-sheet versions have a blind plate too (see Fig. 1-2).

No electrical and gas connections are realized from the front panel.

At BINOS E front panel rear side (see Fig. 1-3) there are mounted different components if the corresponding options are chosen.

Fastening screws for rack mounting or carrying-strap bracket

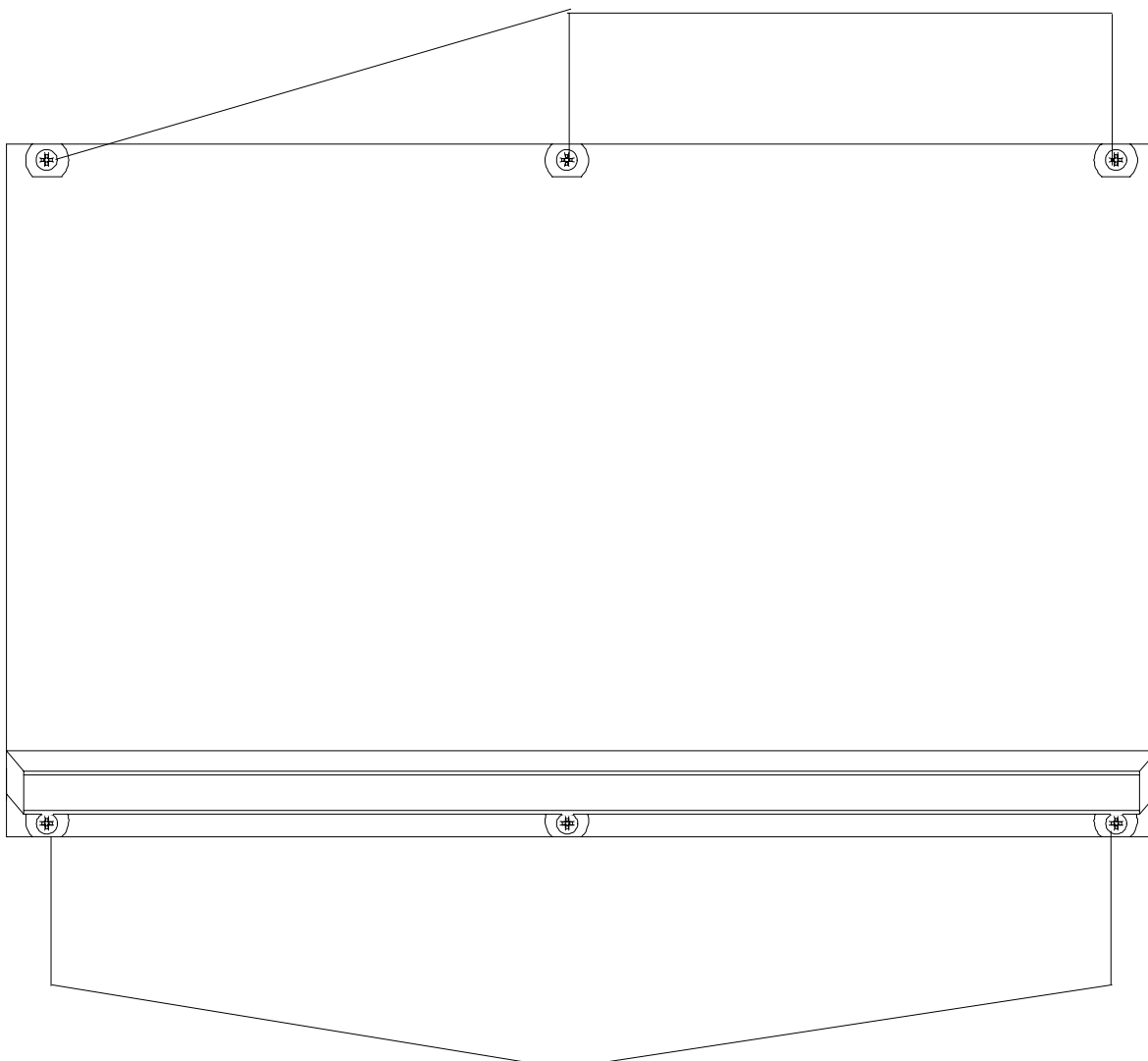

Fastening screws for rack mounting or carrying-strap bracket

**Fig. 1-1: BINOS E front panel, Front view**

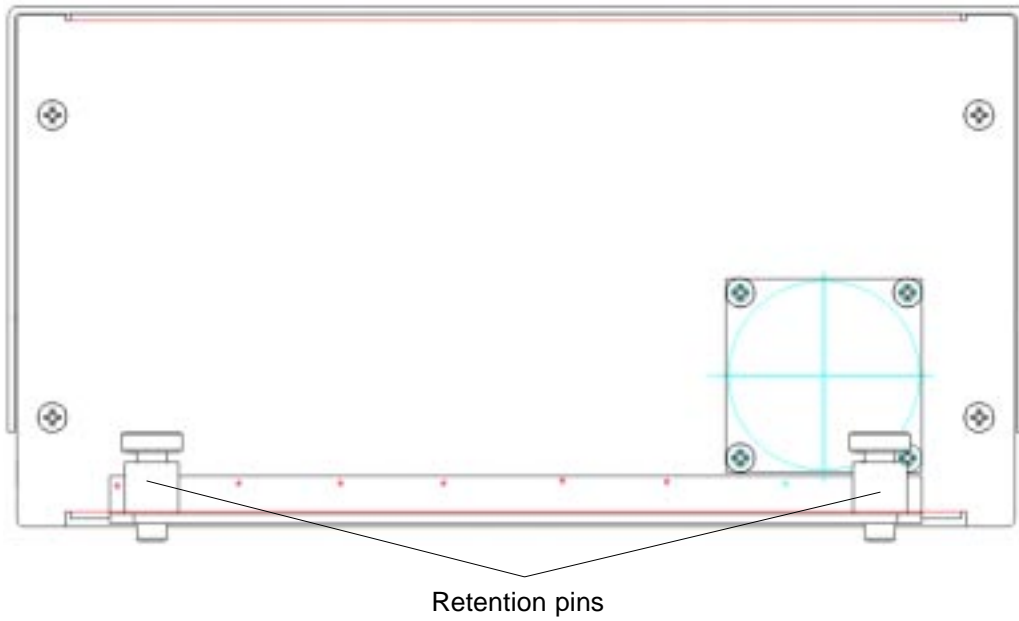

**Fig. 1-2: BINOS E Sheet-metal Housing , Front panel, Front view**

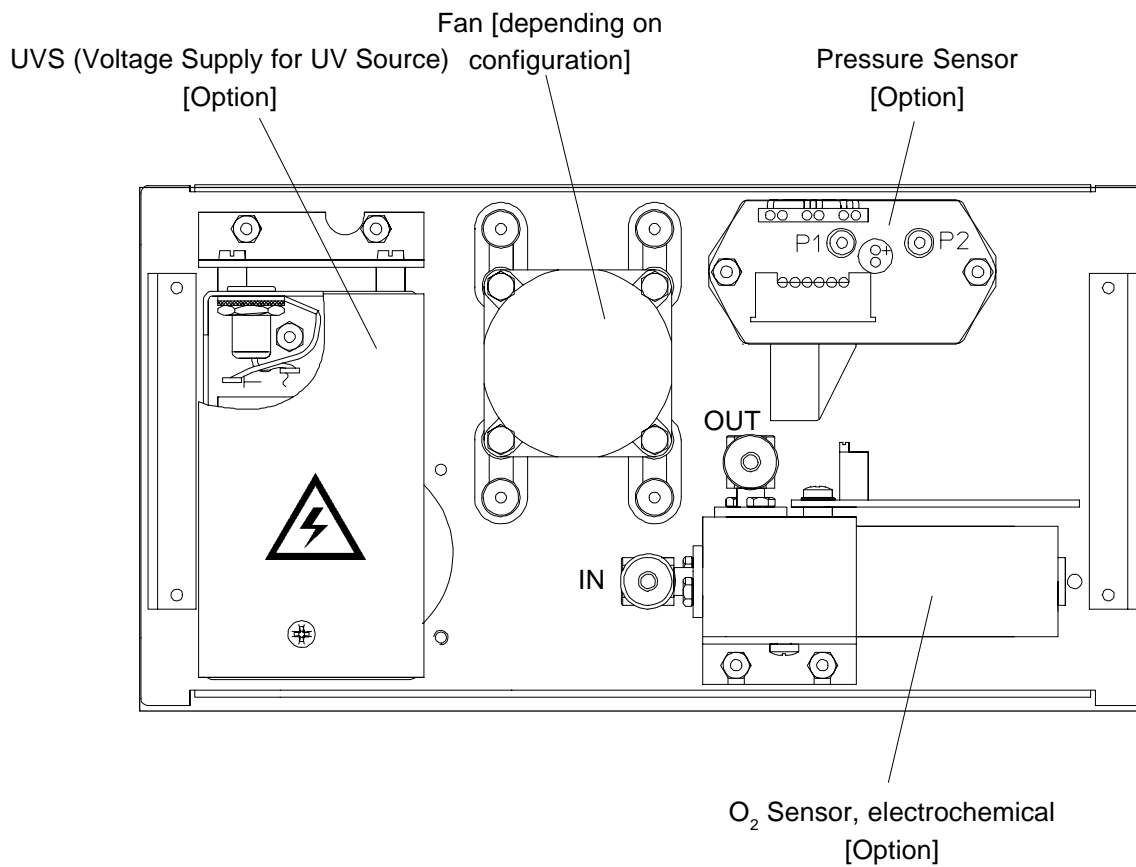

**Fig. 1-3: BINOS E, Front panel, Rear view**

## 1.2 Rear Panel

On the BINOS E rear panel the connector for 24 Vdc supply, the gas connections and the connectors for Input/output modules (standard and optional I/O's) are accommodated.

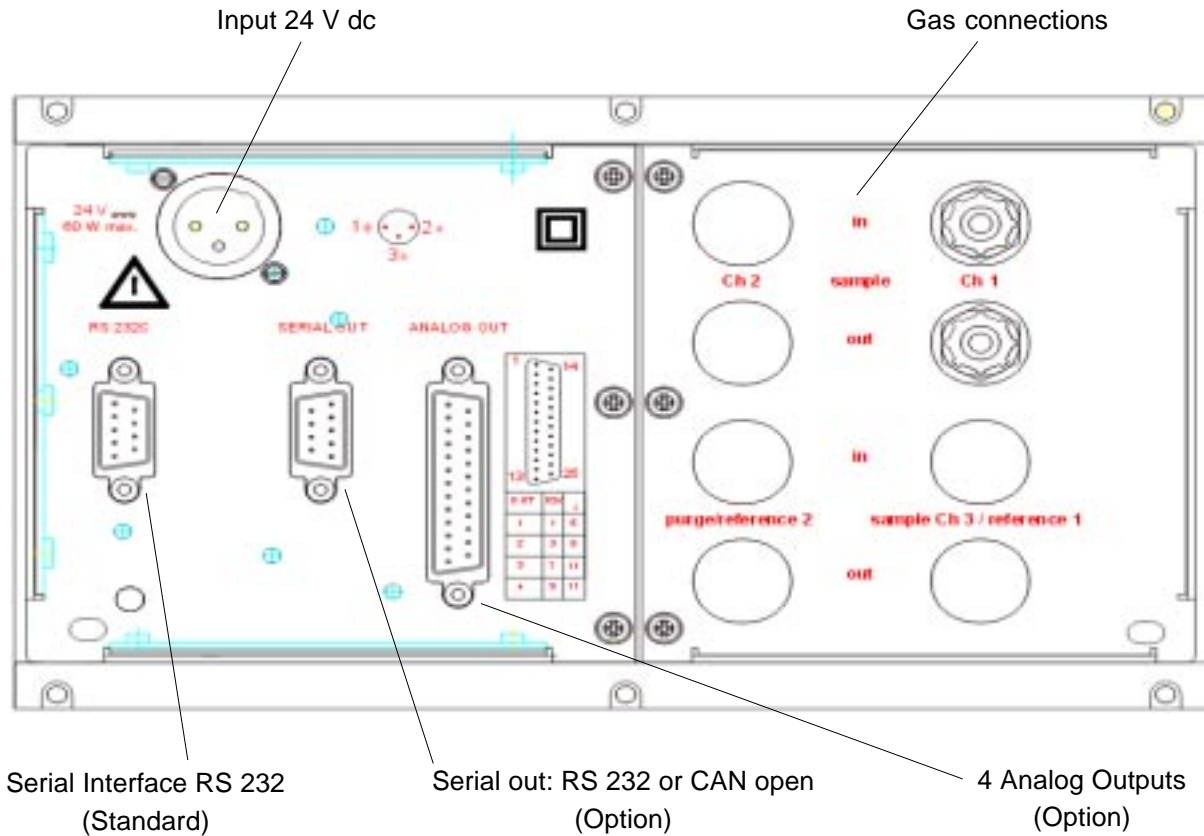

**Fig. 1-4: BINOS E, Rear panel (including all options)**

### 1.3 Internal Construction (Component Layout)

Regarding BINOS E from the front, the electronic unit with interconnection PCB and other PCBs are located on the right. The photometer assembly and other parts are located on the left.

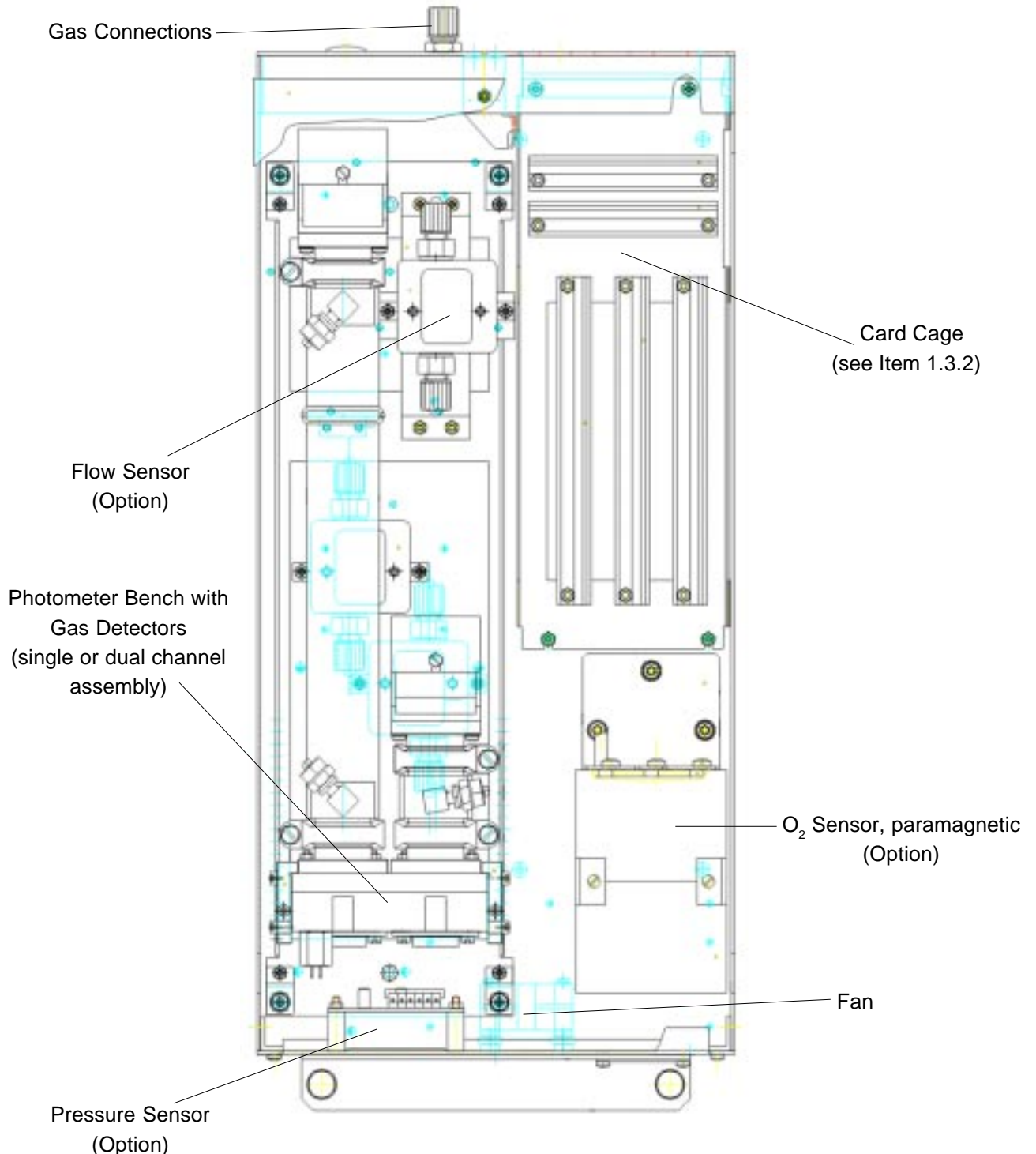

**Fig. 1-5: BINOS E, Sheet-metal Housing, Top view**  
 (with 2 NDIR channels & paramagnetic O<sub>2</sub> Sensor)

Gas Connections

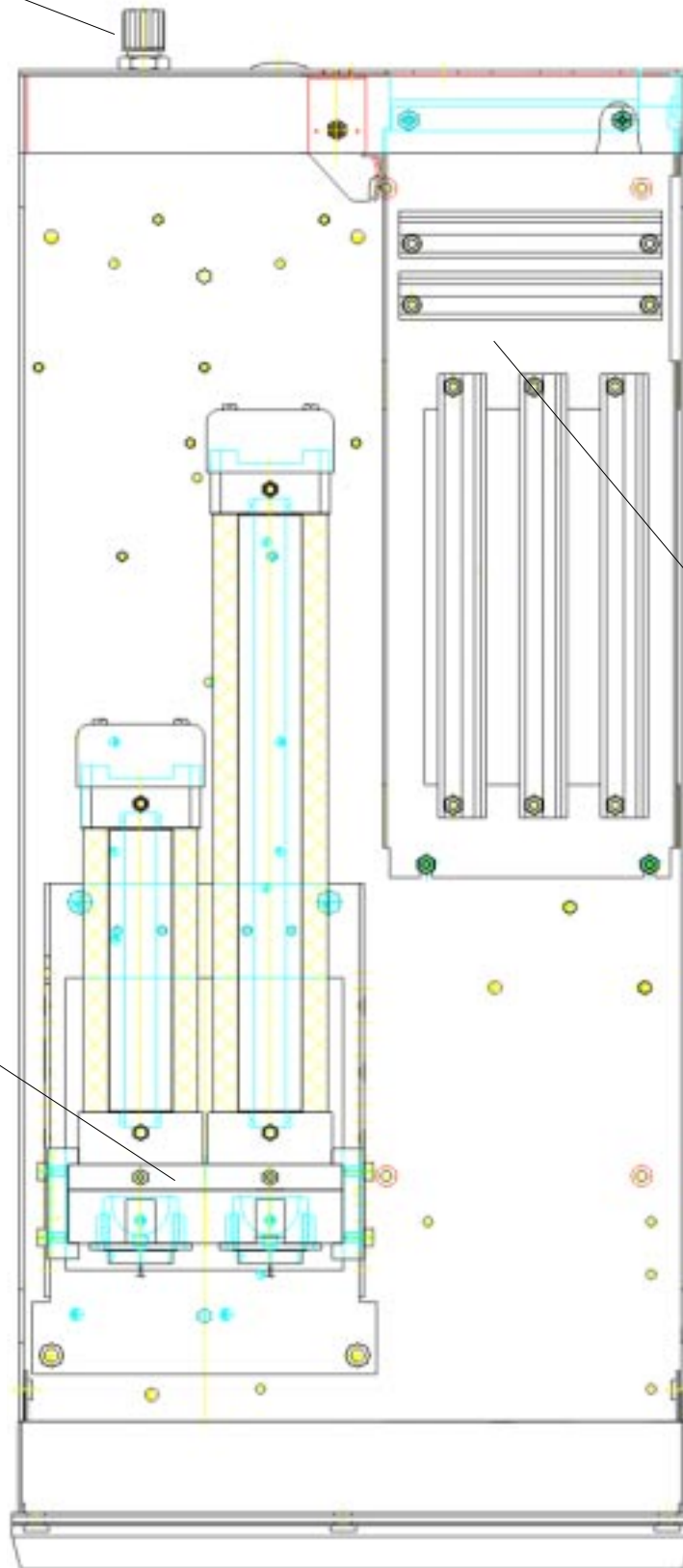

Card Cage  
(see Item 1.3.2)

Photometer Bench with  
Pyroelectrical Detectors  
(single or dual channel  
assembly)

**Fig. 1-6: BINOS E, 1/2 19" Analyzer Housing, Top view**  
(with 2 NDIR channels)

### 1.3.1 Internal Gas Paths

The materials used for the gas paths may be selected to suit the intended application. In making such selection the diffusion rates of the individual gas components, their corrosivity, and the temperature and pressure of the sampled gas must be taken into account.

#### a) Gas Path Material

The physical and chemical properties of the sample gas and the operating conditions (temperature and pressure) of the analyzer determine the materials which may be used for gas paths and gas fittings.

##### Fittings

For standard applications the analyzers are provided with PVDF fitting, 6/4 mm. The analyzers can be shipped with swagelok® fittings, stainless steel, 6/4 mm or 1/4" as option.

Additional fittings to be delivered on request, consult factory.

##### Tubing

For standard applications the analyzers are provided with Viton or PTFE tubing (6/4 mm). Stainless steel tubing is available for one or two gas paths. Other configurations with ss tubing may be provided on request. Special tubings may be on request after consulting factory.

##### Safety Filter

For standard applications the analyzers are provided with a safety filter (PTFE). This filter is no substitute for a fine dust filter in the sample handling system.

**b) Gas Path Layout (internal tubing)**

The principle various possible layouts of the internal gas lines are summarized in the table 1-1.

tubing in series	
tubing in parallel	
combined tubing: series and parallel (special tubing)	

**Table 1-1: Possible internal tubings (examples with 3 measuring channels)**



### 1.3.2 Printed Circuit Boards

All necessary PCBs are placed into a cardcage, which is identically for all BINOS E versions (see Fig. 1-7).

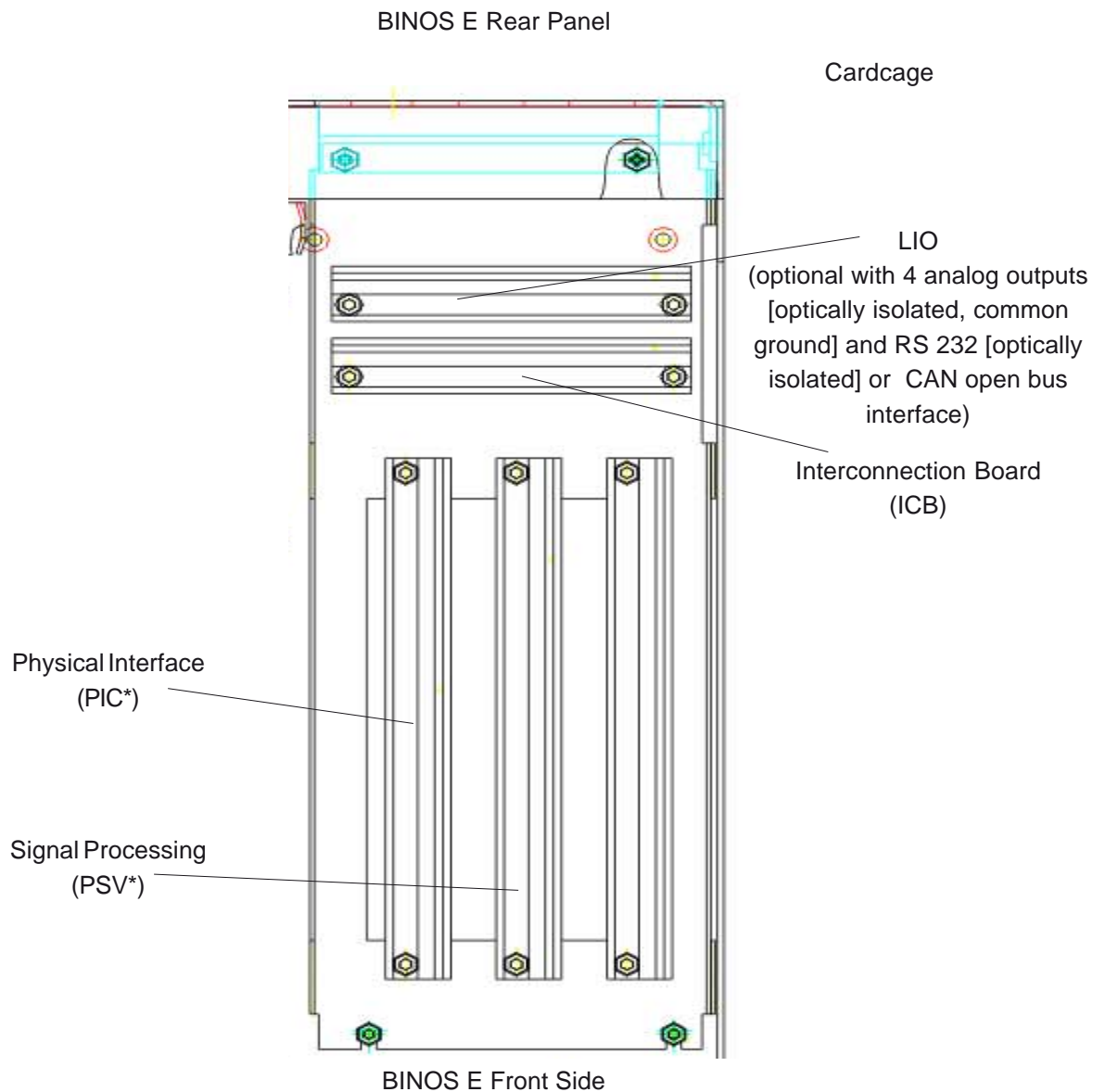

\* For new models the combination PIC/PSV is replaced by a single DSP board.

**Fig. 1-7: Card Cage BINOS E, Top View**

## ICB

ICB is an interconnection board consisting of six 64-pin ICB bus slots to accommodate printed circuit boards (PCB of Euro standard format).

## LIO

The printed circuit board LIO offers the serial interface RS 232 and as an option 4 analog outputs and an optically isolated serial interface or CAN open.

## PSV/PIC Combination \*)

The PSV card (signal processing) carries out the A/D conversion and the real evaluation of each measuring signal. This includes also all primary and all secondary variables: all concentrations, temperatures, pressures and flow measurements. Any temperature and pressure compensation is carried out from PSV. Linearization, zero and span calibration are also executed in the PSV card.

The PIC card (Physics Interface Card) supplies the photometer components and the individual sensors with the individual required operating voltages and transmits all measuring signals to the signal processing unit PSV.

## DSP (alternatively to PSV/PIC Combination) \*)

The DSP card (Digital Signal Processing) supplies the photometer components and the individual sensors with the individual required operating voltages and carries out the A/D conversion and the real evaluation of each measuring signal.

\*) For new models the combination PIC/PSV is replaced by a single DSP board.

**PIC**

The PIC card (Physics Interface Card) supplies the photometer components and the individual sensors with the individual required operating voltages and transmits all measuring signals to the signal processing unit PSV.

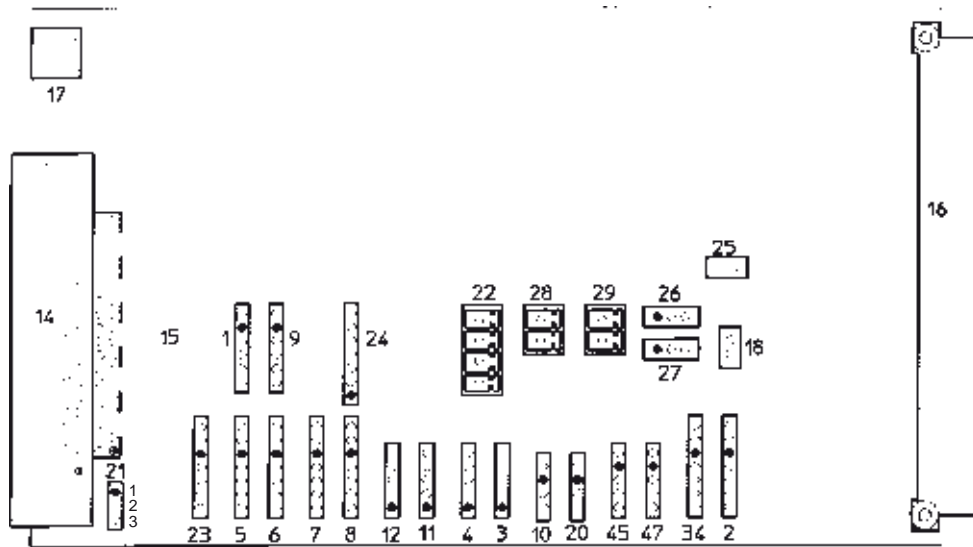

**Fig. 1-8: Plug pin assignment PCB PIC**

The plugs shown in Fig. 1-20 are used as follows:

Plug No.	used	Plug No.	used
34	Chopper 1 (channel 1+2)	1	Pressure sensor 1
2	Chopper 2 (channel 3+4)	9	Pressure sensor 2
47	Flow sensor 1	24	PCB OKI (P2) Flow sensor 3 PCB OKI (P1) Flow sensor 4 (P1) or PCB OKI (P4) Temperature sensor 3 PCB OKI (P3) Temperature sensor 4
45	Flow sensor 2	21.2	Proof peak (test peak) channel 1
20	Temperature sensor 1 (chopper 1)	21.3	Ground (⊥)
10	Temperature sensor 2		
3	Source channel 4		
4	Source channel 3		
11	Source channel 2		
12	Source channel 1		
8	Detector channel 4		
7	Detector channel 3		
6	Detector channel 2		
5	Detector channel 1		
23	Detector channel 5 (O <sub>2</sub> )		

### Digital Signal Processing Card (DSP)

Instead of using the 2 PCB's PIC and PSV alternatively those can be replaced by ONE board containing both functions in the Digital Signal Processing Board DSP.

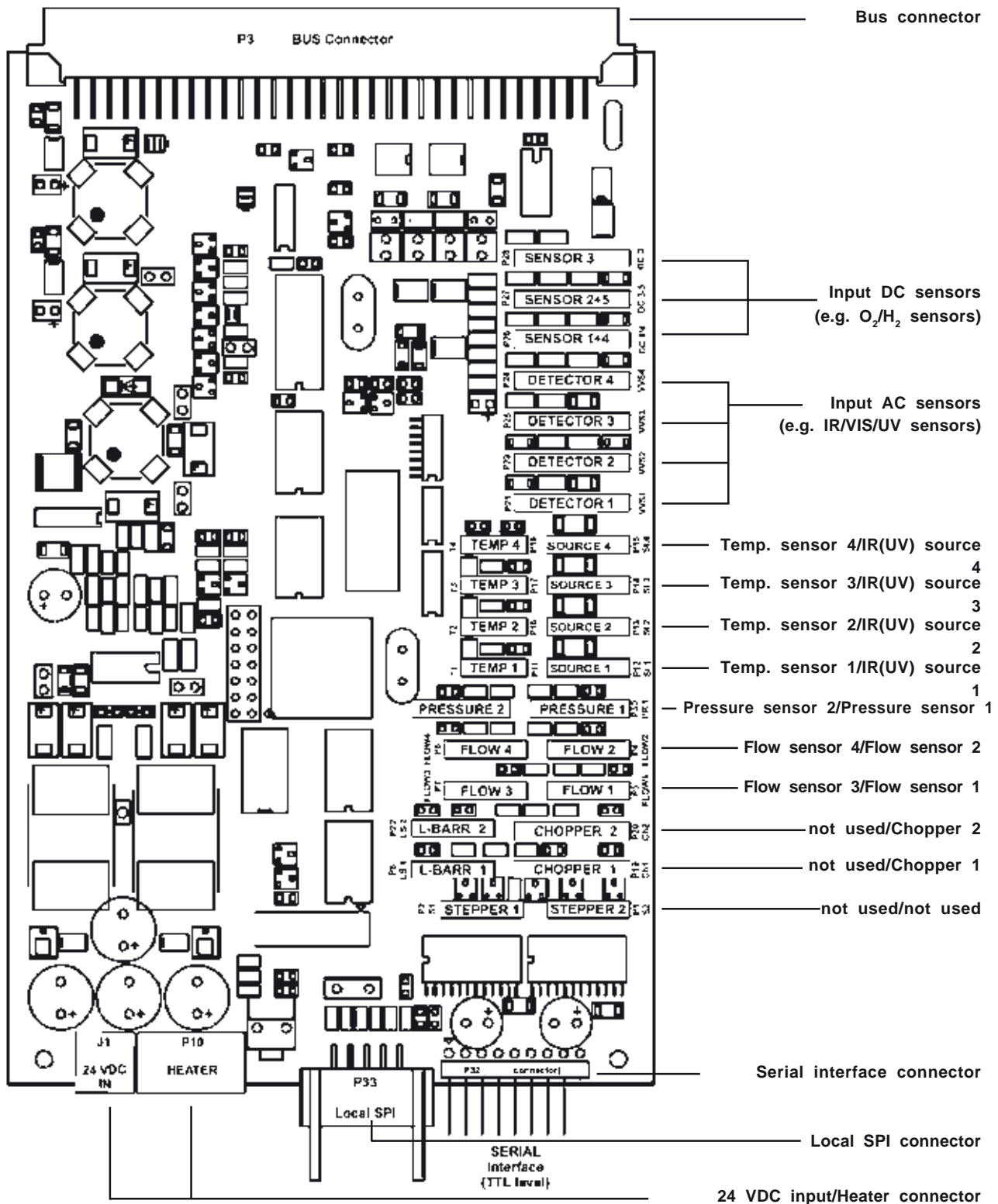

Fig. 1-9: Plug pin assignment PCB DSP

## **2. Measuring Principle**

BINOS E can employ up to four different measuring principles depending on the configuration chosen. The methods are: NDIR, NDUV, paramagnetic and electrochemical Oxygen.

### **2.1 Non-dispersive Infrared (NDIR Measurement)**

The non-dispersive infrared method is based on the principle of absorption of IR radiation by the sample gas component being measured. The gas - specific wavelengths of the absorption bands characterize the type of gas while the strength of the absorption gives a measure of the concentration of the gas component being measured. An optical bench is in principle consisting of an infrared light source, a chopper wheel to alternate the radiation intensity between the reference and measurement (sample) side, an analysis cell, filter cells and a photometric detector. Due to a rotation chopper wheel, the radiation intensities coming from measuring and reference side of the analysis cell produce periodically changing signals within the detector.

The detector signal amplitude thus alternates between concentration dependent and concentration independent values. The difference between the two is a reliable measure of the concentration of the absorbing gas component.

The principle photometer assembly is shown in Fig. 2-1.

Depending on the gas being measured, the application, the gas composition and the gas concentration, one of two different measuring methods may be used as follows:

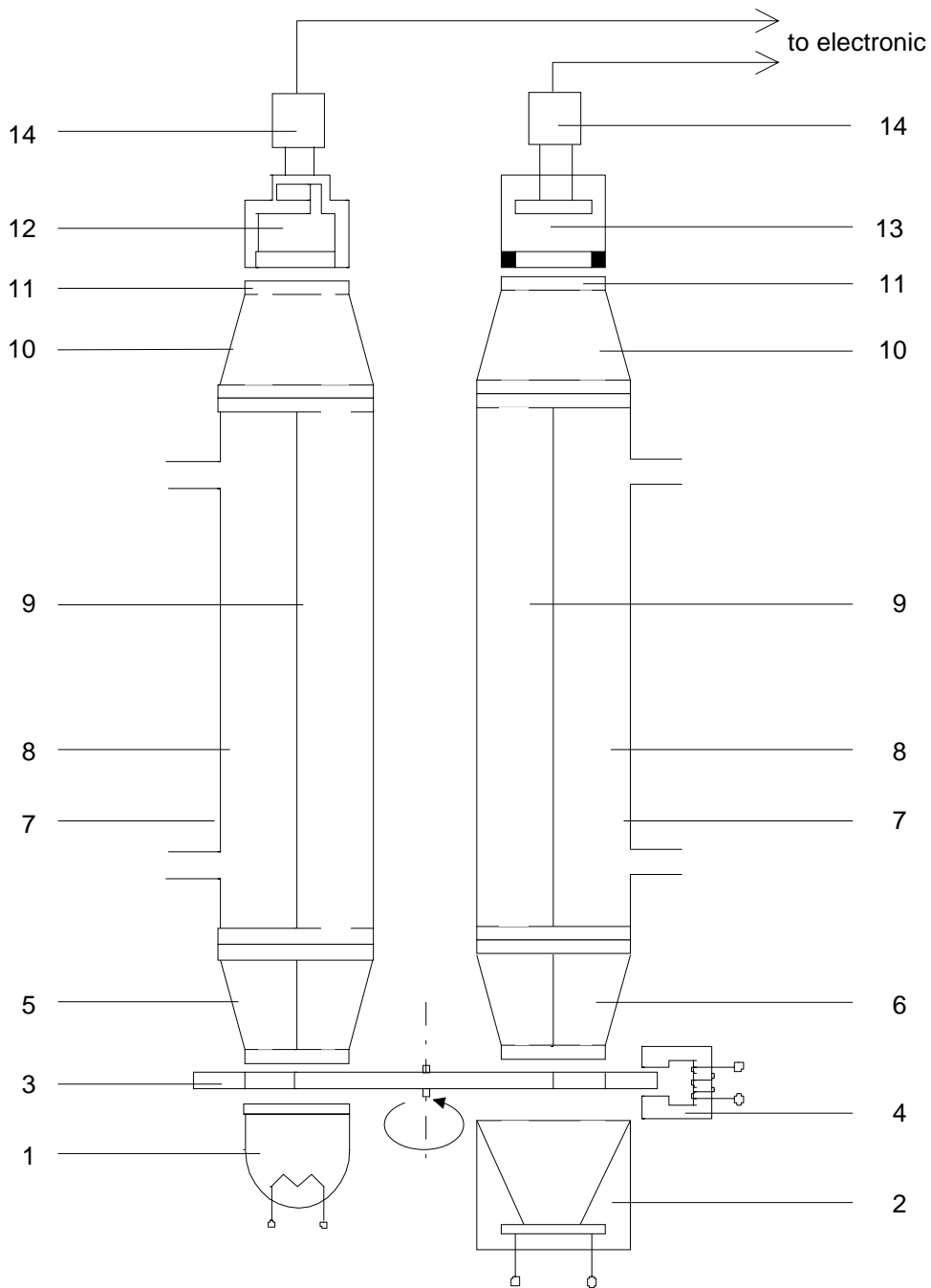

**Fig. 2-1: Measuring Principle for NDIR / UV Measurement**

- |   |   |    |   |
|---|---|----|---|
| 1 | IR source with reflector                    | 8  | Measuring side  |
| 2 | VIS / UV source with reflector              | 9  | Reference side  |
| 3 | Chopper wheel                               | 10 | Filter cell without dividing wall<br>(for IFC measurement with optical filters) |
| 4 | Eddy current drive                          | 11 | Window  |
| 5 | Filter cell with dividing wall (IR channel) | 12 | Pneumatic or pyroelectrical (solid-state) detector                              |
| 6 | Filter cell with dividing wall (UV channel) | 13 | VIS / UV semiconductor detector   |
| 7 | Analysis cell                               | 14 | Preamplifier  |

### 2.1.1 Opto - Pneumatic Measuring Principle

In the opto-pneumatic method, a thermal radiator ( heating coil in the light source) generates the infrared radiation (1) which passes through the chopper wheel (3).

Due to the special shape of the chopper wheel, the IR radiation passes through a filter cell (5) and alternately reaches the measuring side (8) and reference side (9) of the analysis cell [(7) separated in the middle into two halves by an internal separating wall] with equal intensity.

The filter cell (5) screens interfering radiation areas out of the radiation spectrum.

After the analysis cell the radiation passes a second filter cell (10) and reaches the gas detector (12), which compares the IR radiation intensities from measuring side and reference side and converts it into an AC voltage signal proportional to their respective intensity.

The opto-pneumatic detector (Fig. 2-2) consists of 2 gas-filled chambers, an absorption chamber and a compensation chamber which are connected by a flow channel in which a Microflow filament sensor is mounted.

In principle the detector is filled with the infrared active gas to be measured and is only sensitive to this distinct gas with its characteristic absorption spectrum. The absorption chamber is sealed with a window which are transparent for infrared radiation [usually  $\text{CaF}_2$  (Calcium fluoride), sometimes  $\text{BaF}_2$  (Barium fluoride)].

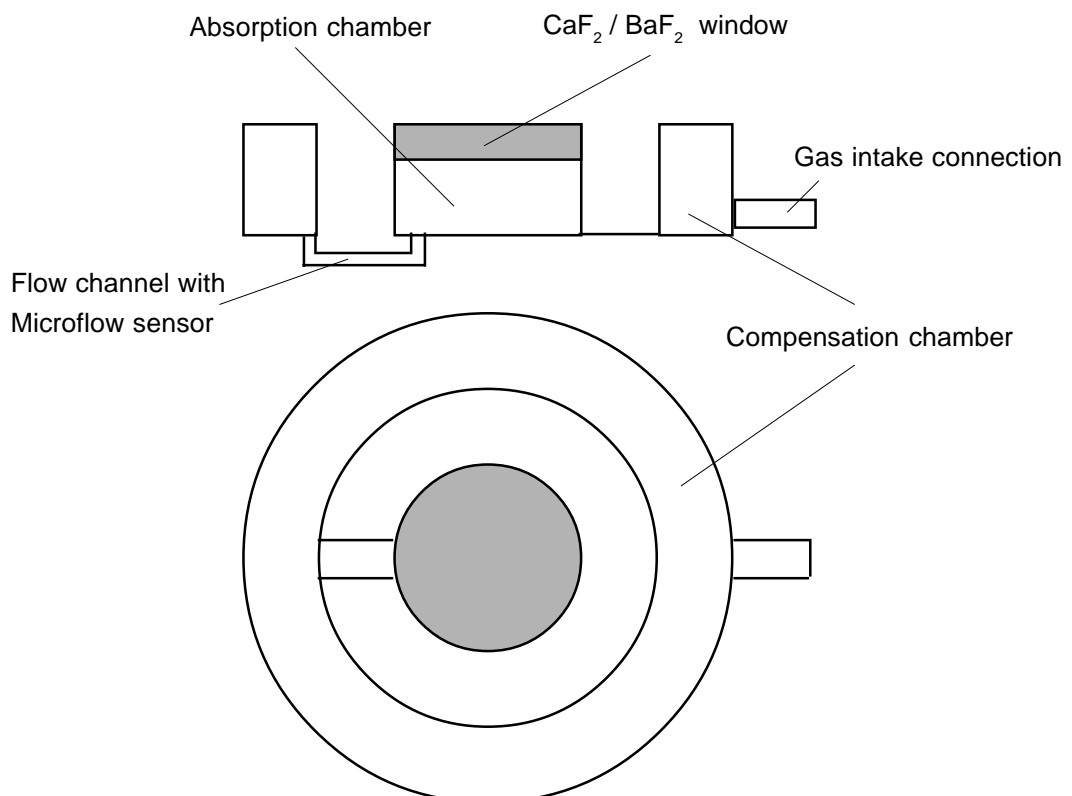

**Fig. 2-2: Principle Design of the Opto-Pneumatic Gas Detector**

When the IR radiation passes through the reference side of the analysis cell into the detector, no pre-absorption occurs. Thus, the gas inside the absorption chamber is heated, expands and some of it passes through the flow channel into the compensation chamber.

When the IR radiation passes through the measurement side of the analysis cell into the detector, a part of it is absorbed depending on gas concentration. The gas in the absorption chamber, therefore, is heated less than in the case of radiation coming from the reference side. Now absorption chamber gas become colder, gas pressure in the absorption chamber is reduced and some gas of compensation chamber passes through the flow channel into the absorption chamber.

The flow channel geometry is designed in such a way that it hardly impedes the gas flow by restriction. Due to the radiation of chopper wheel, the different radiation intensities lead to periodically repeated flow pulses within the detector.

The Microflow sensor evaluates these flow pulses and converts them into electrical voltages. The electronics, which follow, evaluate the signals and convert them into the corresponding display and output format.

The high chopping rate used, permits using a portion of the perimeter of the chopper wheel for responsivity recalibration. A special pattern of the chopper wheel illuminates the detector with about 1/4 and then with about 3/4 of the total light intensity creating a so-called "proof peak". Thus, with any chopper rotation, an automatic gain control is used for automatic span (sensitivity) control. The result is a high long-term stability of sensitivity.

### **2.1.2 Interference Filter Correlation (IFC Principle)**

With the IFC method the analysis cell is alternately illuminated with filtered IR light concentrated in one of two spectrally separated wave length ranges. One of these two wavelength bands is chosen to coincide with an absorption band of the sample gas and the other is chosen such that none of the gas constituents expected to be encountered in practice absorbs anywhere within the band.

The spectral transmittance curves of the interference filters used in the BINOS and the spectral absorption of the gases CO and CO<sub>2</sub> are shown in Fig. 2-3. It can be seen that the absorption bands of these gases each coincide with the passbands of one of the interference filters.



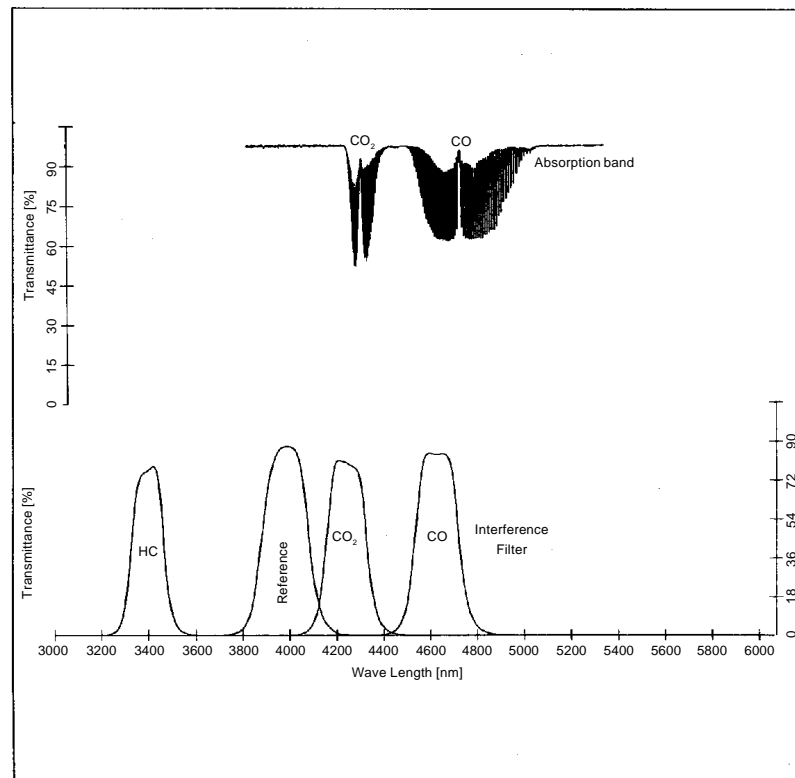

**Fig. 2-3: Absorption Bands of Sample Gase Components and Transmittance of Interference Filters**

The interference filter, used for generating a reference signal, has its passband in a spectral region where none of these gases absorb. Most of the other gases of interest also do not absorb within the passband of this reference filter.

The photometer assembly is similar to the assembly with “gas detector” (Fig. 2-1) with the exception of the analysis cell and the detector. The analysis cell is not divided into measuring and reference side (selectivity by interference filters). After the analysis cell the radiation passes a second filter cell (10) to reach the pyroelectrical (solid-state) detector (12).

The detector records the incoming IR radiation. This radiation will be reduced by the absorption of the gas at the corresponding wavelengths. By comparing the intensities from the measuring and reference wavelengths, an alternating voltage signal is produced. This signal results from cooling and heating the pyroelectrical material.

## 2.2 UV Measurement

The absorption measurement in the UV spectral range is based on the same principle as the IR measurement (Fig. 2-1).

A glow-discharge lamp [2] is used as radiation source.

The UV radiation passes through the chopper [3] and a filter cell [6] into the dual-section analysis cell [7].

A second filter cell [6] is installed after the analysis cell. The photodetector [13], which follows, converts the pulsating radiation intensities from measuring [8] and reference side [9] of the analysis cell into electrical voltages.

As the glow-discharge lamp needs a specific and as constant as possible temperature, the UV lamp is thermostat controlled to about 55 °C for BINOS E.

## 2.3 Oxygen Measurement

Depending on analyzer model different two measuring methods will be used.

### 2.3.1 Paramagnetic Measurement

The determination of O<sub>2</sub> concentration is based on the paramagnetic principle (magneto-mechanic principle).

Two nitrogen-filled (N<sub>2</sub> is diamagnetic) quartz spheres are arranged in a "dumbbell" configuration and suspended free to rotate on a thin platinum ribbon in a cell.

A small mirror that reflects a light beam coming from a light source to a photodetector, is mounted on this ribbon. A strong permanent magnet especially shaped to produce a strong highly inhomogeneous magnetic field inside the analysis cell, is mounted outside the wall.

When oxygen molecules enter the cell, their paramagnetism will cause them to be drawn towards the region of greatest magnetic field strength. The O<sub>2</sub> molecules thus exert different forces which produce a torque acting on the sphere arrangement, and the suspended "dumbbell", along with the mirror mounted on its suspension ribbon, will be angularly rotated away from the equilibrium position.

The mirror then will deflect an incident light beam onto the photodetector which itself produces an electric voltage. The electric signal is amplified and fed back to a conducting coil at the "dumbbell", forcing the suspended spheres back to the equilibrium position.

The current required to generate the restoring torque to return the "dumbbell" to its equilibrium position is a direct measure of the O<sub>2</sub> concentration in the gas mixture.

The complete analysis cell consists of analysis chamber, permanent magnet, processing electronics, and a temperature sensor. BINOS E provides a thermostat controlled sensor at approx. 55 °C. The temperature sensor is used to control the heating system.

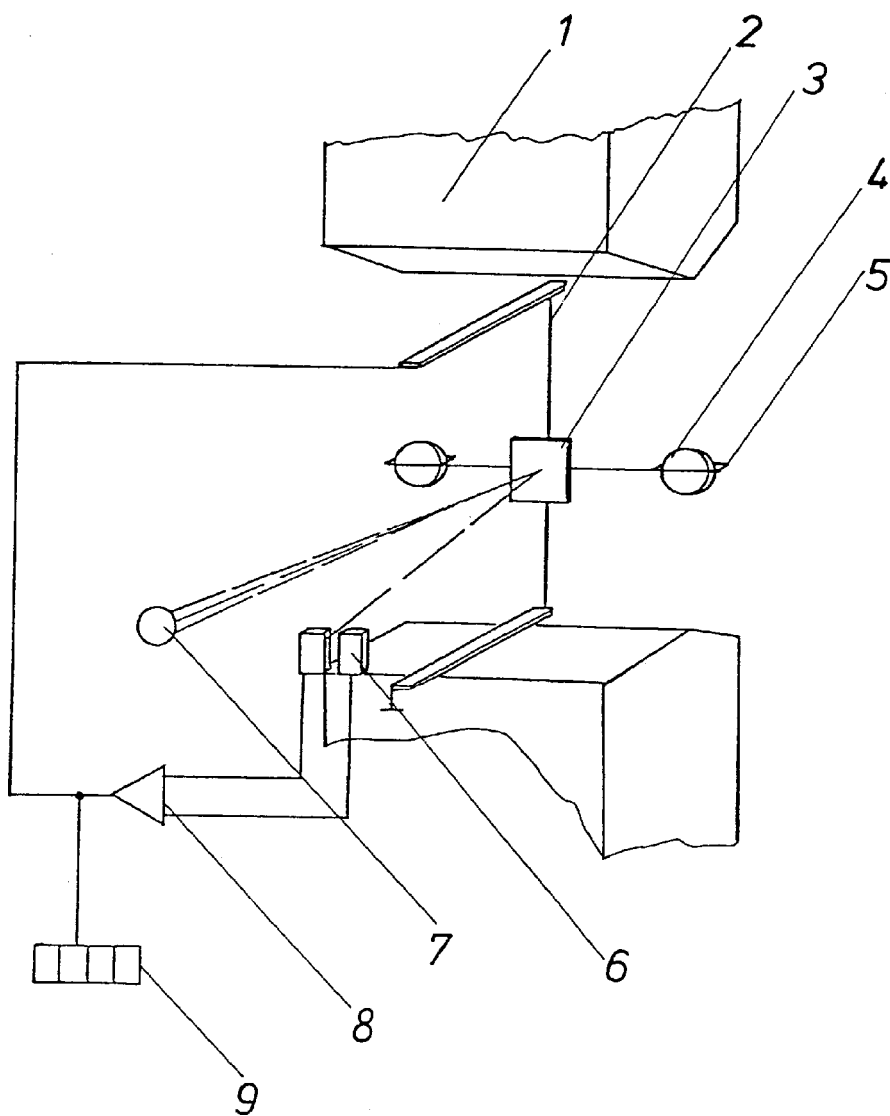
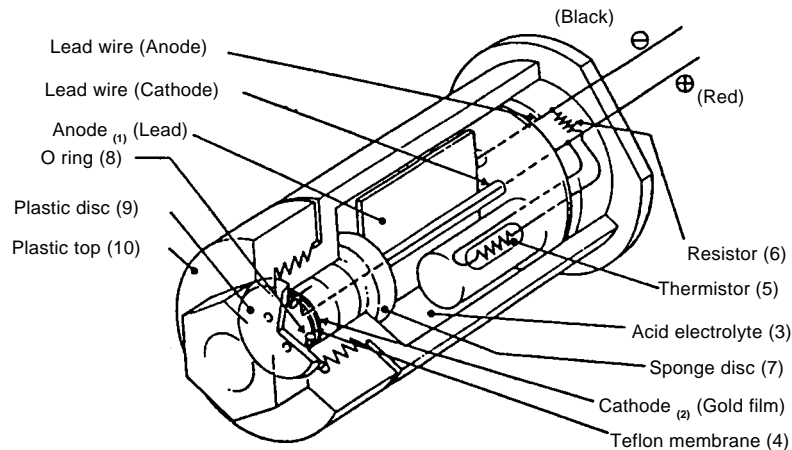

**Fig. 2-4: Principle Construction of paramagnetic Analysis Cell**

- 1 Permanent magnet
- 2 Platinum wire
- 3 Mirror
- 4 Quartz spheres
- 5 Wire loop
- 6 Photodetector
- 7 Light source
- 8 Amplifier
- 9 Display

### 2.3.2 Electrochemical Measurement

The determination of O<sub>2</sub> concentrations is based on the principle of a galvanic cell. The principle structure of the oxygen sensor is shown in Fig. 2-5.



**Fig. 2-5: Structure of electrochemical Oxygen Sensor**

The oxygen sensor incorporates a lead/gold oxygen cell with a lead anode (1) and a gold cathode (2), using a specific acid electrolyte. To avoid moisture losses at the gold electrode a sponge sheet is inserted on the purged side.

Oxygen molecules diffuse through a non-porous Teflon membrane (4) into the electrochemical cell and are reduced at the gold-cathode. Water results from this reaction.

On the anode lead oxide is formed which is transferred into the electrolyte. The lead anode is regenerated continuously and the electrode potential therefore remains unchanged for a long time.

The rate of diffusion and so the response time ( $t_{90}$ ) of the sensor is depending on the thickness of the Teflon membrane.

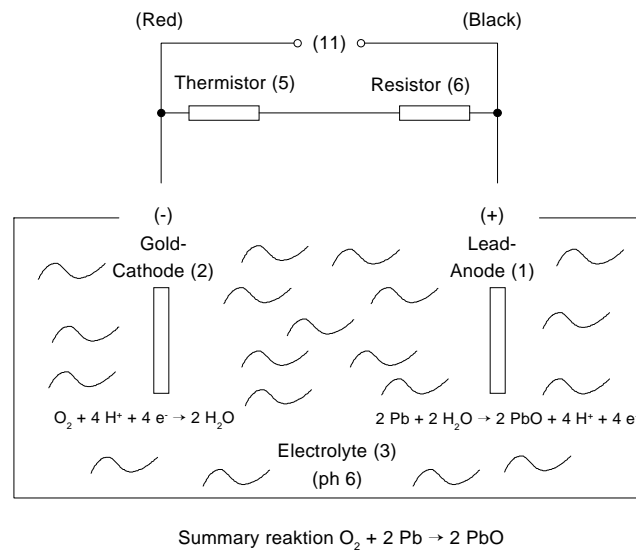

**Fig. 2-6: Reaction of galvanic cell**

The electric current between the electrodes is proportional to the  $O_2$  concentration in the gas mixture to be measured. The signals are measured as terminal voltages of the resistor (6) and the thermistor (5) for temperature compensation.

The change in output voltages (mV) of the sensor (11) represents the oxygen concentration.

**Note !**

Depending on measuring principle the electrochemical  $O_2$  cell needs a minimum internal consumption of oxygen (residual humidity avoids drying of the cell) . Supply cells continuously with dry sample gas of low grade oxygen concentration or with oxygenfree sample gas could result a reversible detuning of  $O_2$  sensitivity. The output signal will become unstable.

For correct measurement the cells have to be supplied with  $O_2$  concentrations of at least 0.1 Vol.-%. We recommend to use the cells in intervall measurement (purge cells with conditioned (dust removal but no drying) ambient air during measurement breaks).

If it is necessary to interrupt oxygen supply for several hours or days, the cell has to regenerate (supply cell for about one day with ambient air). Temporary flushing with nitrogen ( $N_2$ ) for less than 1 h (e.g. analyzer zeroing) will have no influence to measuring value.

## 5. Installation and Preparation of Startup

Please check the packing and its contents immediately upon arrival.

If any item is damaged or lost you are kindly requested to notify the forwarder to undertake a damage survey and report the loss or damage to us immediately.



If vibration decoupling is installed: Unscrew transfer safety lock of BINOS E !  
 Unscrew both knurled-head screws on bottom side of the housing (Fig. 5-1a) ! For protection against loss screw the knurled-head screws into the respective holders at housing rear side (Fig. 5-1b) !

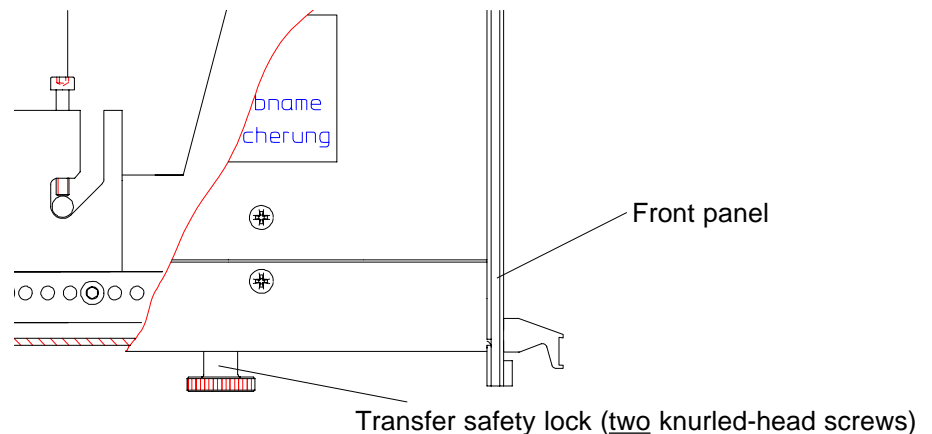

**Fig. 5-1a: Transfer safety lock**  
 (housing side view, detail sketch)

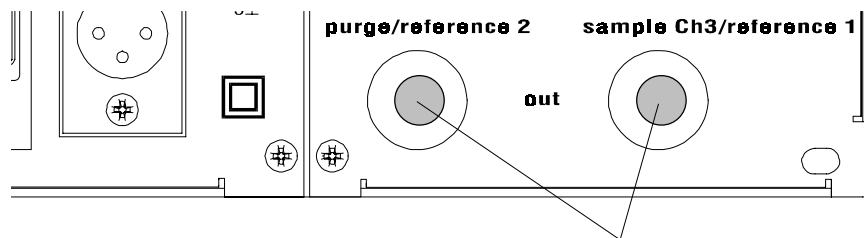

**Fig. 5-1b: BINOS E, Rear panel** (holder for safety lock)

## 5.1 Installation Site



Be sure to observe the additional notes, safety precautions and warnings given in the individual manuals!



The BINOS E must not operate in explosive atmosphere without supplementary protective measures !



Free flow of air into and out of the BINOS E (ventilation slits) must not be hindered by nearby objects or walls !



The installation site for the BINOS E has to be dry and remain above freezing point at all times. The BINOS E must be exposed neither to direct sunlight nor to strong sources of heat.

Be sure to observe the permissible ambient temperatures (c.f. Item 20: Technical Data). For outdoor installation, we recommend to install the BINOS E in a protective cabinet. At least, the BINOS E has to be protected against rain (e.g., shelter).

The BINOS E has to be installed **as near as possible to the sample point**, in order to avoid low response time caused by long sample gas lines.

In order to decrease the response time, a sample gas pump with a matching high pumping rate may be used. Eventually, the BINOS E has to be operated in the bypass mode or by an overflow valve to prevent too high flow and too high pressure (Fig. 5-2).

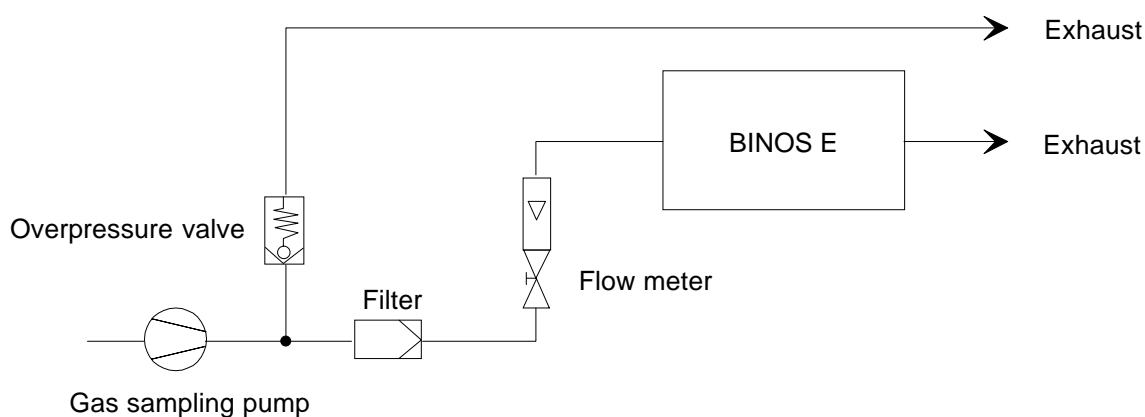

**Fig. 5-2: BINOS E, Bypass installation**



## 5.2 Gas Conditioning (Sample Handling)

The conditioning of the sample gas is of greatest importance for the successful operation of any analyzer according to extractive method.



All gases have to be supplied to the BINOS E as conditioned gases !  
When the instrument is used with corrosive gases, it is to be verified that there are no gas components which may damage the gas path components.

The gas has to fulfill the following conditions:

It must be

- free of condensable constituents
- free of dust
- free of aggressive constituents which are not compatible with the material of the gas paths.
- have temperatures and pressures which are within the specifications shown in “Technical Data” of this manual.



Flammable or (potential) explosive gas mixtures may not be introduced into the BINOS E without supplementary protective measures !

When analysing vapours, the dewpoint of the sample gas has to be at least 10 °C below the ambient temperature in order to avoid the precipitation of condensate in the gas paths.

Suitable gas conditioning hardware may be supplied or recommended for specific analytical problems and operating conditions.

### 5.2.1 Pressure Sensor (Option)

It is possible to integrate up to two pressure sensors with a range of 800 - 1100 hPa. The concentration values computed by the analyzer will then be corrected to reflect the barometric pressure to eliminate faulty measurements due to changes in barometric pressure (see technical data). BINOS E front panel program will indicate whether pressure correction is actual.

### 5.2.2 Gas Flow Rate / Internal Flow Sensor (Option)

The gas flow rate should be within the range 0.2 l/min to maxi. 1.5 l/min !

A constant flow rate of about 1 l/min is recommended.



The gas flow rate for BINOS E with paramagnetic oxygen sensor is allowed to max. 1.0 l/min !  
Internal flow sensor: max. 2.0 l/min !

It is possible to integrate up to three flow sensors. In this case gas flow can be shown via BINOS E front panel program.

## 5.3 Gas Connections

The installed gas connections are specific to the different BINOS E. All fittings are clearly marked. The fittings are located on the rear panel of the BINOS E instrument.



The exhaust gas lines have to be mounted in a declining, pressureless and frost-free way and according to the valid emission legislation !



Do not interchange gas inlets and gas outlets !

### 5.3.1 Standard

Depending on BINOS E version the following gas connections are installed:

in = Gas inlet	out = Gas outlet
Channel 1 = measuring channel 1	Channel 2 = measuring channel 2
Channel 3 = measuring channel 3	reference = Reference gas (Differential measurement)
	purge = purge gas (housing)

Zero gas and span gas are introduced directly via the sample gas inlet. The test gas containers have to be set up according to the current legislation.



Be sure to observe the safety regulations for the respective gases (sample gas and test gases / span gases) and the gas bottles !

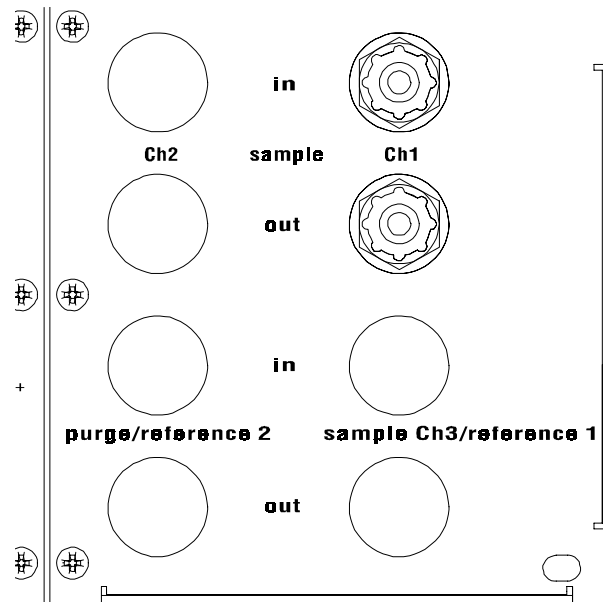

**Fig. 5-3: BINOS E, standard gas connections**



## 6. Startup Procedure (Switching On)

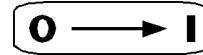

### **Be sure to observe the safety precautions and warnings !**

Be sure to observe the additional notes, safety precautions and warnings given in the individual manuals !

Once the instrument has been correctly assembled and installed in accordance with the general instructions given in section 5., the equipment is ready for operation. The equipment is switched on by providing the required voltage.

Upon switching on, the analyzer will perform a self-diagnostic test routine.

The BINOS E front panel program should be installed before connecting the BINOS E to the designated COM port.

The following devices are recommended to connect BINOS E with the PC:

- Zero modem cable (part number: ETC00257)
- Gender changer (part number: ETC00258)

For additional informations about recommended hardware and software requirements, see chapter "Front Panel Program".



Analyzer needs 15 to 50 minutes to warm-up after switch on, depending on the installed detectors (thermostat controlled temperature) !

## 6.1 Supply Voltage

The BINOS E is specified for an operating voltage of 24 V DC ( $\pm 5\%$ ).

24 Vdc is to be connected via a 3-pole XLR flange (male).

The dc supply voltage is to be provided by option UPS 01 T, SL5, SL10 or equivalent power supply.

- Connect power supply and BINOS E (Fig. 6-1, Plug 24 V DC).



Verify correct polarity before operation (Fig. 21-1) !

- Connect mains line and power supply.



Be sure to observe the safety precautions and warnings given by manufacturer of power supply !

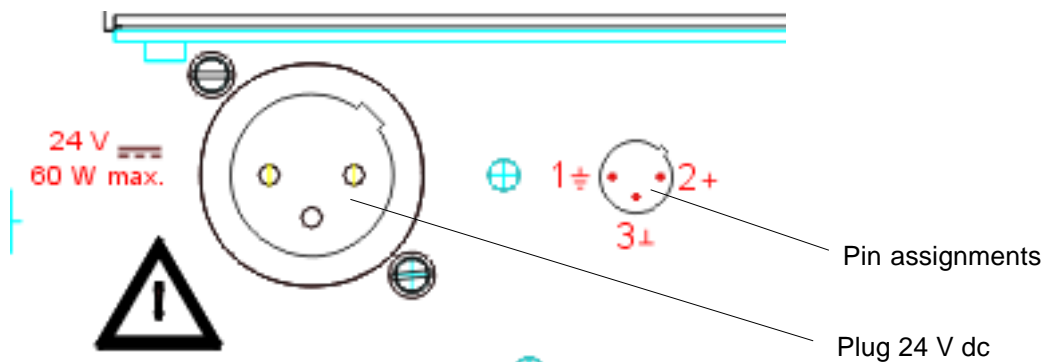

**Fig. 6-1: BINOS E, Rear panel, Voltage supply**

## 7. Measurement / Calibration / Switching (Shut) Off

### 7.1 Measurement



The primary step in the measurement of the concentration of a gas component is the admission of sample gas to the analyzer.



Analyzer needs 15 to 50 minutes to warm-up after switch on, depending on the installed detectors (thermostat controlled temperature) !

- Admit sample gas at the respective gas inlet fitting (see Item 5.).
- Set the gas flow rate to allowable rate.

Before starting an analysis, however, the following should be performed:

- BINOS E front panel program should be installed and BINOS E should be connected to the designated COM port. Initialization from connected analyzer or from configuration file should have been carried out.
- Zero and span gas calibration of the BINOS E (see chapter 8).

#### **Note for analyzers with electrochemical O<sub>2</sub> cell!**

Depending on measuring principle the electrochemical O<sub>2</sub> cell needs a minimum internal consumption of oxygen (residual humidity avoids drying of the cell). Supply cells continuously with dry sample gas of low grade oxygen concentration or with oxygenfree sample gas could result a reversible detuning of O<sub>2</sub> sensitivity. The output signal will become unstable.

For correct measurement the cells have to be supplied with O<sub>2</sub> concentrations of at least 0.1 Vol.-%. We recommend to use the cells in intervall measurement (purge cells with conditioned (dust removal but no drying) ambient air during measurement breaks).

If it is necessary to interrupt oxygen supply for several hours or days, the cell has to regenerate (supply cell for about one day with ambient air). Temporary flushing with nitrogen (N<sub>2</sub>) for less than 1 h (e.g. analyzer zeroing) will have no influence to measuring value.

## 7.2 Calibration

To insure correct measurement results, zeroing and spanning should be carried out once a week.

The zero level must always first be set before any other calibrations are attempted.

For the calibration procedure the required test gases have to be fed to the analyzer through the respective gas inlets (cf. section 5.3) with a no - back - pressure gas flow rate of about 1 l/min (the same as with sample gas) !

### 7.2.1 Calibration (Test) Gases

#### a) Zero Gas

For zeroing, the analyzer has to be purged with nitrogen ( $N_2$ ) or adequate zero gas [e. g. synth. air or conditioned air (not as a standard for  $O_2$  measurement)].

#### b) Span Gas

The calibration of all another analyzers should be done with pure span gases in order to prevent interferences between the gases (e. g.,  $CO_2$  and CO) measured by the analyzer. Test gas mixtures are also possible depending on the mixed components (c.f. or test gas supplier).

The concentration range of the span gas has to be in a range of 80 - 110 % of the full scale range of the respective measuring channel. For lower span gas concentrations the measuring accuracy could be lower for sample gas concentrations, which are higher than the span gas concentration! For test gas concentration see certification of the test gas bottles.

Spanning for oxygen measurement can be done using conditioned ambient air as span gas, if the oxygen concentration is known and constant.

To calibrate a  $H_2O$  channel (0 - 3(4) Vol.-%), use water vapor saturated  $N_2$  according to saturation characteristic (Item 22.) as span gas. Purge  $N_2$  through a gas-blubber bottle, filled with distilled water and in a little bit higher ambient temperature as necessary. Connect a second vessel into a kyrostat (to hold ambient temperature constant) in series to get defined dew point.





Be sure to observe the safety regulations for the respective gases (sample gas and test gases / span gases) and the gas bottles !



Pressure of sample gas / test gases normally max. 1,500 hPa !

### 7.3 Switching (Shut) Off

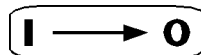

Before switching off the analyzer, we recommend first purging all the gas lines for about 5 minutes with zeroing gas (N<sub>2</sub>) or adequate conditioned air. The full procedure for shutting off is as follows:



All analyzers with electrochemical O<sub>2</sub> cell have to be purged with conditioned ambient air prior to disconnect the gas lines !

Then the gas line fittings have to be closed for transport or depositing analyzer.

- Admit zeroing gas at the respective gas inlet fitting.
- Set the gas flow to permissible rate.

After 5 minutes have elapsed:

- Switch off by disconnecting the voltage supply.
- Shut Off the gas supply.
- Disconnect gas lines.
- Close all gas line fittings immediately.



## **8. BINOS E Front Panel Program**

The description of the BINOS E Front Panel Program includes the following information:

1. Requirements
2. Installation and Startup
3. Function Keys
4. Status Display
5. Display Page
6. Recorder Page
7. Messages Page
8. Analog Output Link and Adjustment Page

### **8.1 Requirements**

Listed below are the minimum recommended hardware and software requirements for installing the BINOS E front panel program in a Microsoft Windows 95, 98 or NT operating system:

- Pentium processor with 233 MHz or better
- 32 MB RAM (higher RAM improves performance)
- Sufficient available hard disk space. The required available space depends on the data acquisition rate (see chapter 5) (Calculate approx. 63 MB per day if the fastest data acquisition is running without data compression).
- 8 MB graphic board
- Serial interface (RS 232 COM port)

The following devices are recommended to connect the BINOS E with your PC:

- Zero modem cable (part number: ETC00257)
- Gender changer (part number: ETC00258)

These accessories can be provided by Fisher-Rosemount with the BINOS E analyzer as options.

## 8.2 Installation and Startup

### 8.2.1 Installation

Start Setup.exe for the BINOS E front panel program installation and follow the program instructions.

The following operations must be activated:

- a) Desired language

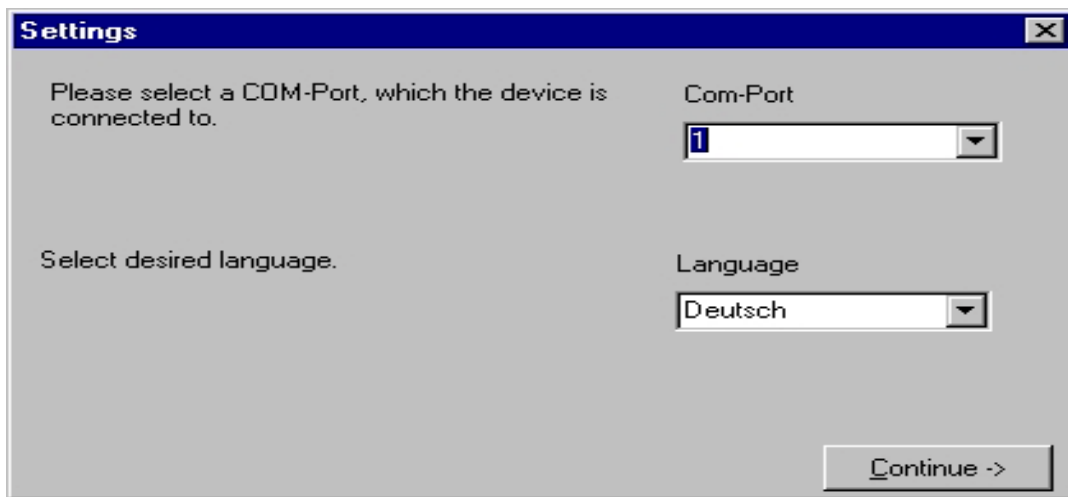

- b) Designated COM port

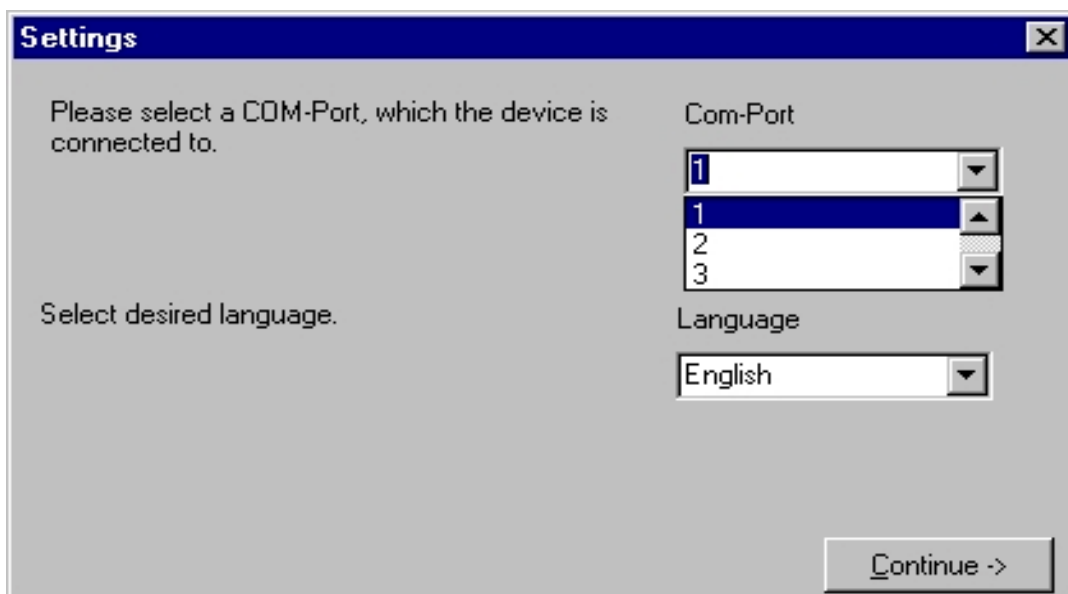

The program will then create the following directory:

C:\ Programs\ Fisher-Rosemount\ BINOS E.

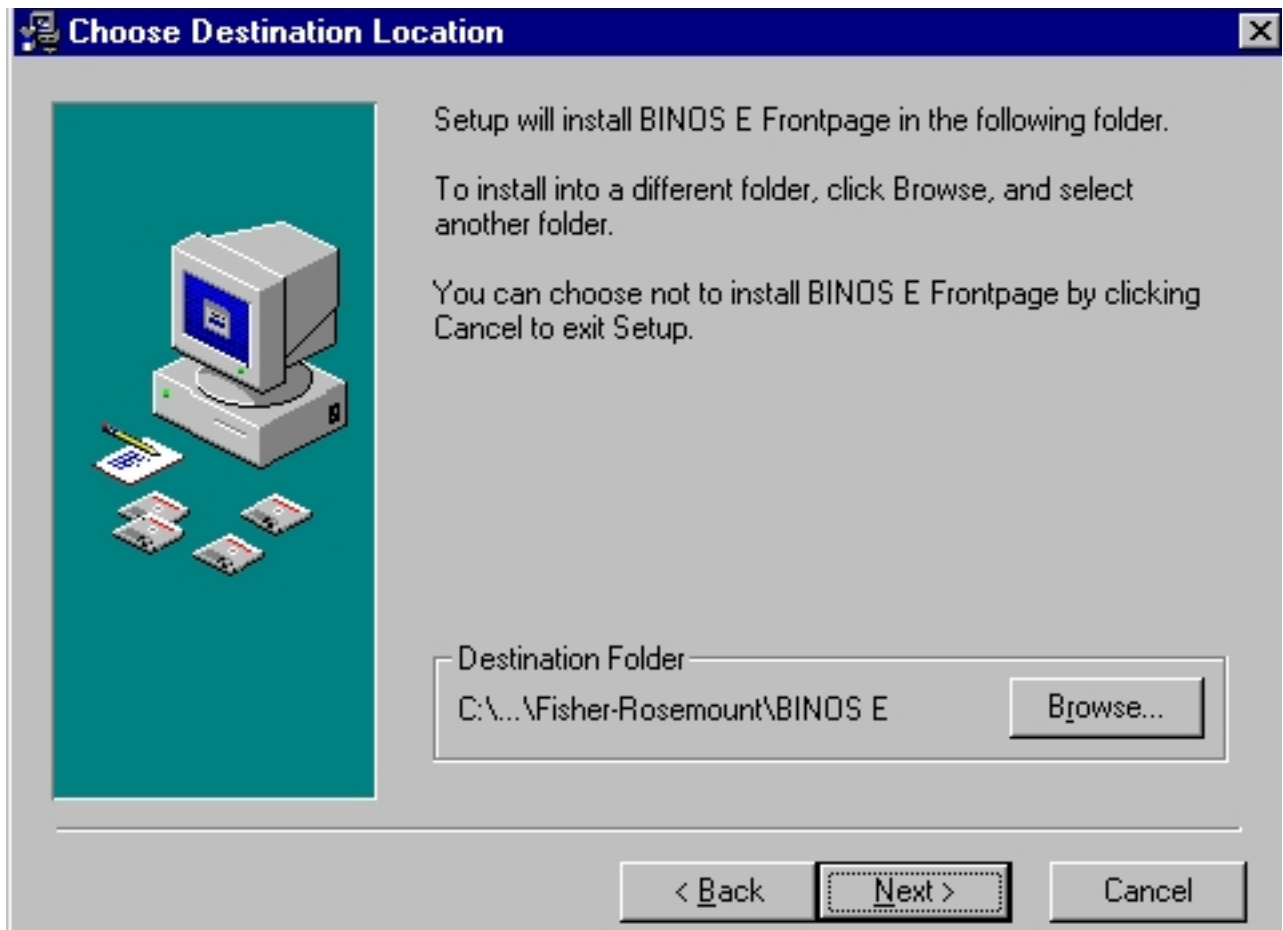

The following files are available in the installation listing:

Ascii.dad (after first measurement), Binos.exe, Binos.eni, BinosOEM.INI, BinosCustom.OEM (after first start, see chapter 8.2), ConfigOEM.INI, daten.ddd, daten.ddt, Default.OEM, README.txt, Install.log, Unwise.exe, Unwise.ini as well as a listing "Data".

After successful installation, a corresponding program group will be generated and the BINOS E program is ready to start.

### 8.2.2 Startup

The first time the BINOS E program is started, a dialog box will inform you that the configuration data is loaded. This procedure may take several seconds.

Based on this data, a standard file "BinosCustom.OEM" will be created. This file will be loaded automatically on any future start to initialize the BINOS E front panel.

Any front panel page (Display, recorder, messages or analog out) offers a headline showing the following information about the specific instrument:

- BINOS E software version (Release Number)
- Adjusted COM port
- BINOS E serial number (important for service and maintenance)

**BINOS E Release 2.0 Fisher-Rosemount GmbH & Co. at COM1**

**serial number: SN-220999262377** 

### 8.3 Function Keys

The function keys F1 through F12 are located on the upper right side of any front panel page:



#### F1 Display:

The "Display" function key enables you to reach the display page of this program (see chapter 8.5) .

#### F2 Recorder:

The "Recorder" function key enables you to reach the recorder page of this program (see chapter 8.6).

#### F3 Messages:

The "Messages" function key enables you to reach the messages page of this program (see chapter 8.7).

#### F4 Analog out.:

The "Analog out." function key (Analog Output Link and Adjustment Page) allows you to link and adjust measuring channels or secondary parameters to the analog outputs and change the settings (see chapter 8.8).

F5 Zero Gas Calib.:

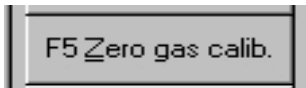

The "Zero gas calib." function key starts the dialog for zero gas calibration.



**ATTENTION:** Before starting zero gas adjustment make certain that zero gas is available!

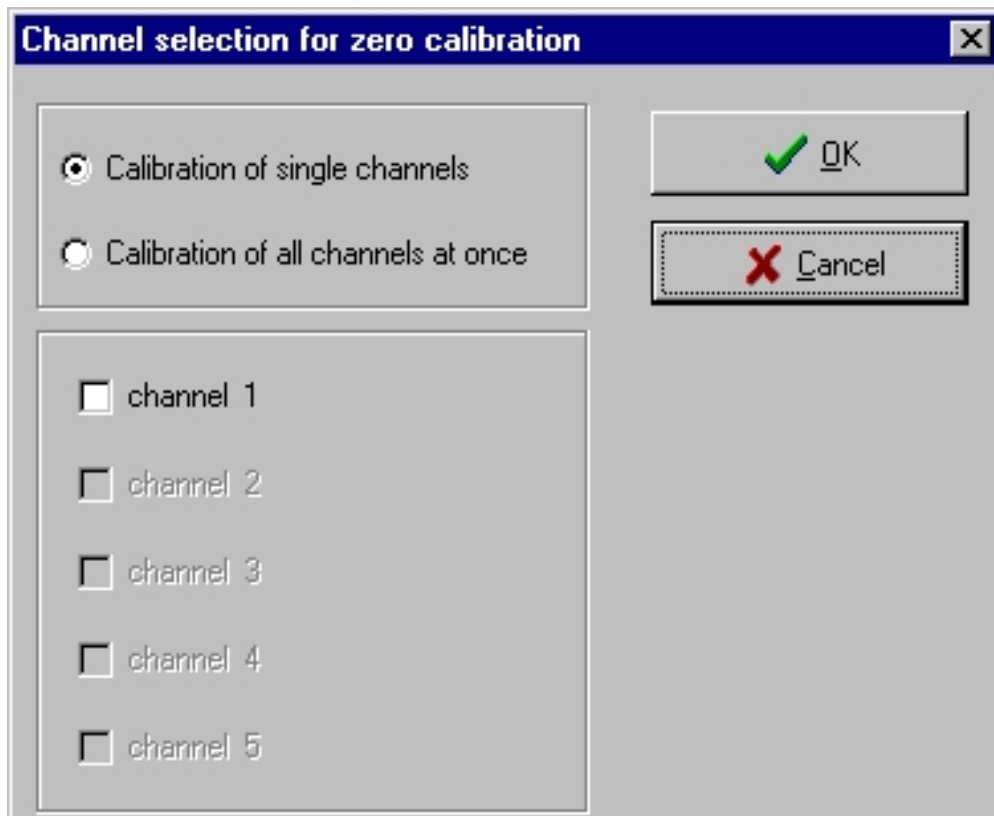

The dialog allows you to select single channels for calibration or to calibrate all channels simultaneously.

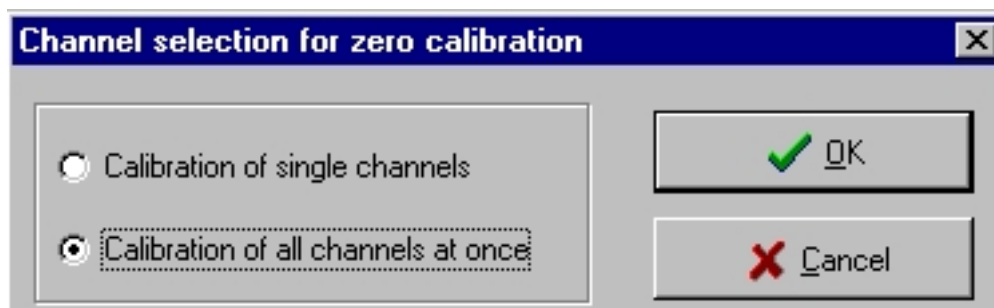

During zero gas adjustment the deviation of the actual value is compared with the max. deviation (threshold value) from the file "BinosOEM.INI".

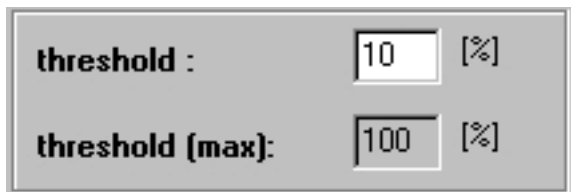

threshold : 10 [%]  
threshold (max): 100 [%]

The menu provides the ability to change the threshold value from 1 % of full scale up to the maximum threshold value.

If the threshold value is exceeded, an alarm message will appear offering the option to stop the zero gas calibration procedure.

F6 Span gas calib.: 

The "Span gas calib." function key starts the dialog for span gas calibration.



**ATTENTION:** Before starting span gas adjustment, ensure that span gas with the desired concentration is available!



**Binos** [X]  
There is no password set!  
Please enter a valid password  
OK

To protect this function against unauthorized access, a password (access code) option is available. If no password has been set you will be asked to define one (this is not required).



**Change password** [X]  
Enter new password  
repeat new password  
OK Cancel

Within this dialog box you can also change the existing access code. If a password is defined, it can be changed but not eliminated entirely.



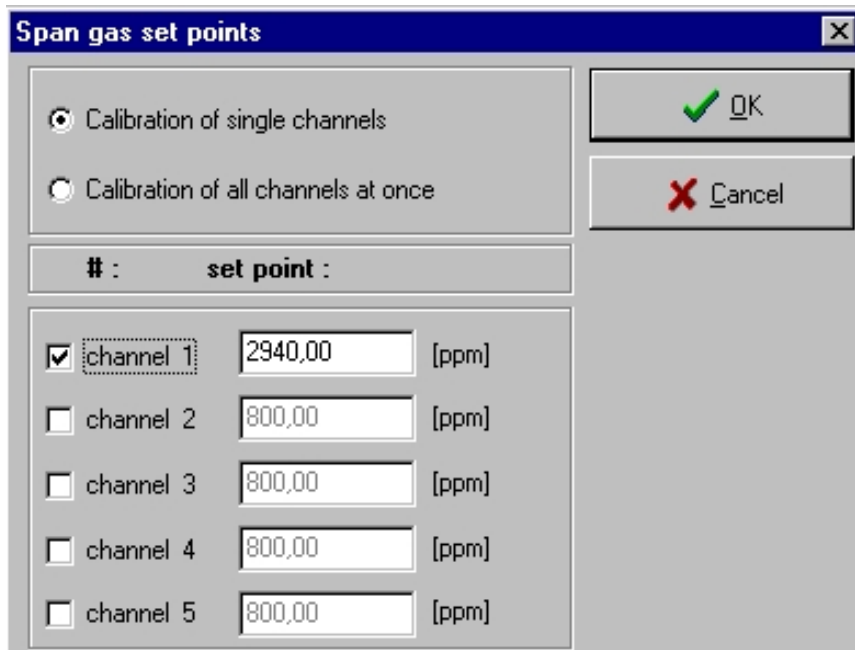

As with zero gas adjustment, you can run span gas calibration with individual selectable channels or with all channels simultaneously.

Unavailable channels will be refused.

You can set the nominal value (set point) in the field behind the corresponding channel.



During span gas adjustment, the deviation of the actual value is compared with the max. deviation (threshold value) from the file "BinosOEM.INI". The menu provides the opportunity to change the threshold value from 1 % of full scale up to the maximum threshold value.

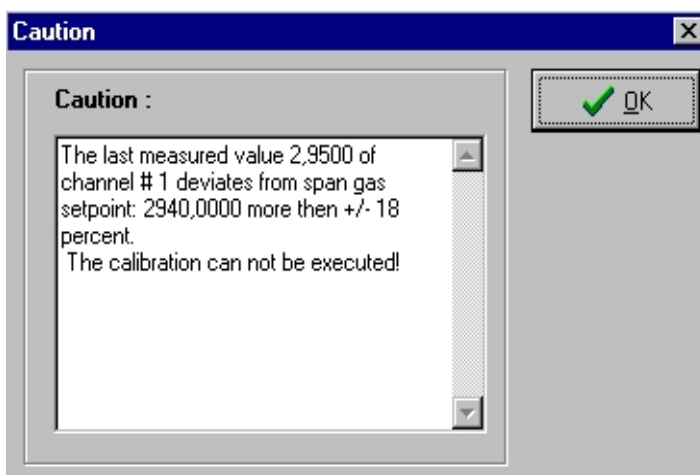

If the value falls below the threshold value, the span gas calibration procedure is stopped.

To enable a span gas calibration, the maximum threshold value may be set (if this does not work contact our Service Support Center).

If any dialog or communication does not work correctly you will get a message indicating the wrong input.

If for example no channel is selected for zero calibration the following message will show up:

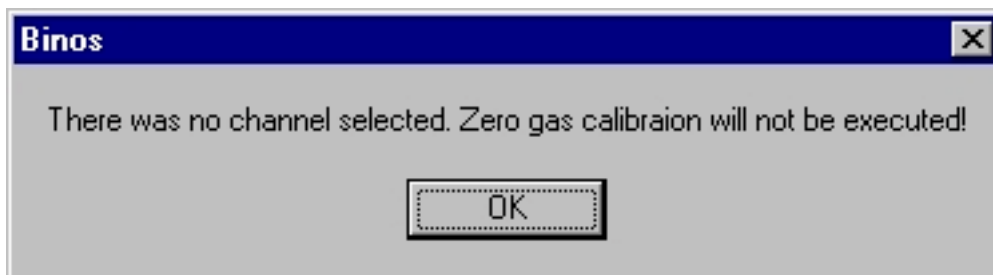

F7 Start measure.:

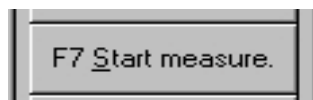

The "Start measure." function key initiates the measuring procedure. After any successful startup the measurement itself needs to be started. Otherwise you see a display being not illuminated.



F8 Stop measure.:

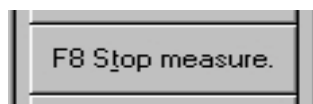

The "Stop measure." function key terminates the measuring procedure. Please wait approximately 30 seconds before any new start.

F9 Raw/Measure:



The "Raw/Measure" function key enables the user to switch from raw data mode [not corrected (unlinearized, not temperature compensated) data] to measurement mode [concentrations]. This procedure may take several seconds.

F10 Initialization:

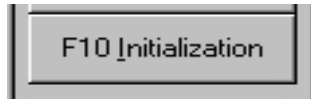

The "Initialization" function key enables two different methods for initialization leading to the dialog box "device data":

If you select in the dialog box "read device data" the option "from connected analyzer" the data will be loaded directly from the connected BINOS E instrument.

If you select the option "from configuration file" within this dialog box, the corresponding configuration file will be selected and loaded.



**ATTENTION:**

The file "BinosCustom.OEM" initially created will not be changed in that case! At the next program start with the option "from connected analyzer" the original status will be restored.

F12 Quit:

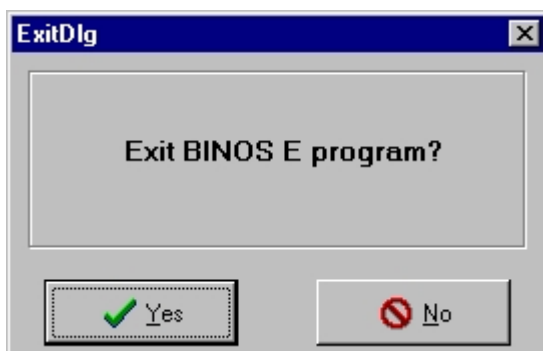
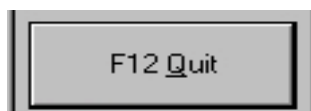

The "Quit" function key ends the program with "Exit BINOS E program".

## 8.4 Status Display ("Status")

The status display on the lower right side of any front panel page shows the actual state of the program:

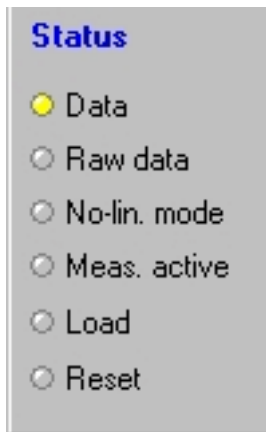

LED "Data": This LED flashes when the BINOS E data is available.

LED "Raw data": This LED is illuminated if the analyzer is working in raw data mode.

LED "Non-lin. Mode": This LED is illuminated during the instrument mode "not linearized".

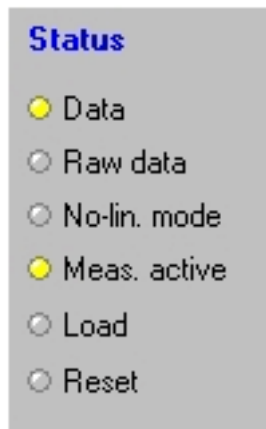

LED "Meas. active": This LED is illuminated during measurement.

LED "Load": This LED is illuminated when configuration data from a connected BINOS E or a file is loaded.

LED "Reset": This LED is illuminated if the software is reset at the instrument. This happens after each initialization.

## 8.5 Display Page

The "Display page" [F1 Display] shows all the connected channels and the accompanying data for the respective gas.

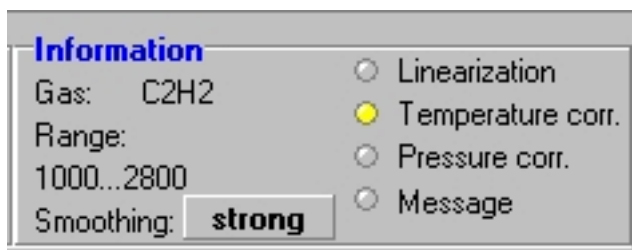

The LED's under the category "Information" indicate the selected configurations and options for each channel. If the LED "Message" is illuminated, a failure message for the respective channel is available on the messages page. The measuring gas and the corresponding smallest and highest ranges are indicated.

A maximum of five channels can be displayed. Active channels are illuminated.

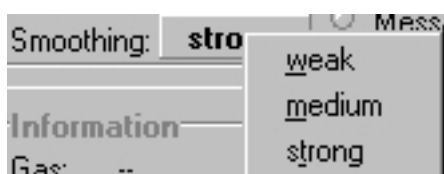

The "smoothing" that allows the  $t_{90}$  time to be adjusted to strong, weak or medium. Selection is activated by clicking the RIGHT MOUSE BUTTON.

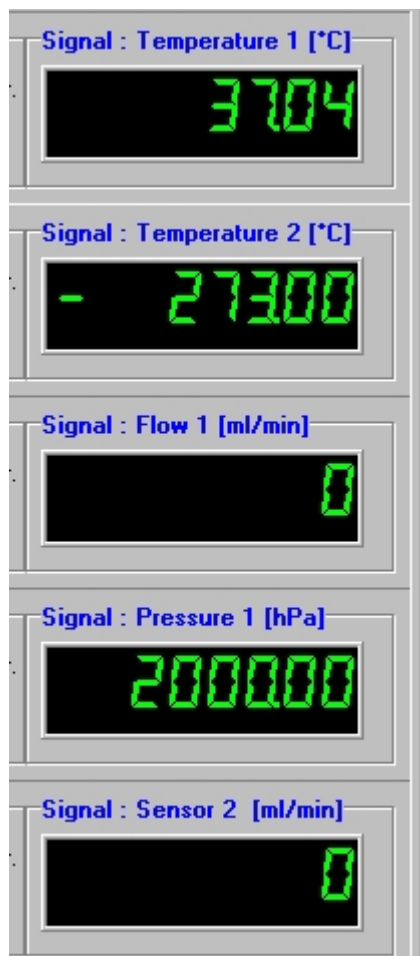

Secondary Parameters:

The option to show five more secondary parameters (signal sources) such as temperature, flow or pressure on an extra panel is available.

To select the source, the user must click the RIGHT MOUSE BUTTON on the title strip of the panel and then select the respective source from the menu.

If a sensor is not available the following signals are displayed:

Temperature: - 273 °C  
Flow: 0 ml/min [cc/min]  
Pressure: 2000 hPa [mbar]

The free selectable sensor can be Temperature, Flow or Pressure indicated by the unit (flow = ml/min).

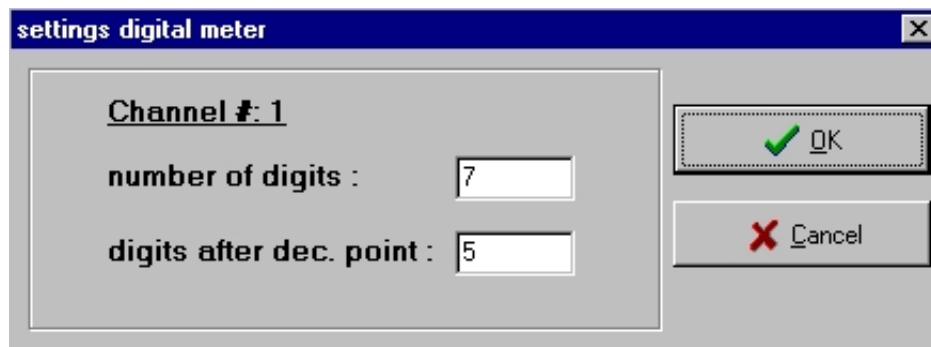

Decimal Places:

The decimal places for the measuring gas concentrations can be adjusted respectively to the ranges.

To adjust the decimal places, click the RIGHT MOUSE BUTTON on the corresponding digital display. If the concentration is indicated in Volume percent (Vol.-%), a maximum of five decimal places can be selected; in the case of ppm, a maximum of three decimal places can be selected.

Additional Data Source:

An additional data source may be adjusted at the bottom of this display page ("Signal selection").



Signal selection can be done with the mouse in the same manner as noted above (RIGHT MOUSE BUTTON).

## 8.6 Recorder Page

For all active channels, a recorder channel is available [F2 Recorder]. Up to five channels can be shown.



For each channel, the recorder adjustments can be set individually. In this case, a dialog box appears after touching the respective button (Recorder 1, 2, 3 ...). Options to adjust the scale individually (manually), to reproduce the factory settings (default values) or to view the actual scale of the recorder (Auto range) are also available.

The decimal places of the scale may be configured here as well.



8.6.1 Averaging:



Using a rotary regulator and a selectable multiplier (1x, 10x, 100x) an average can be calculated for data compression. To calculate the average, the respective multiplier and the desired value at the rotary regulator must be adjusted. The data will then be averaged.



During the measurement no change of averaging is possible!

8.6.2 Spooling:

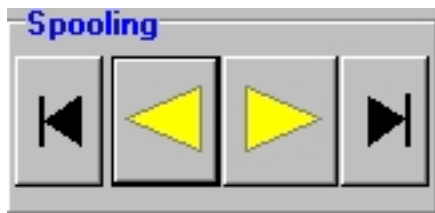

Four spool buttons are available so the user can spool forward, backwards, to the beginning and to the end of the recorded text.

8.6.3 Recording:

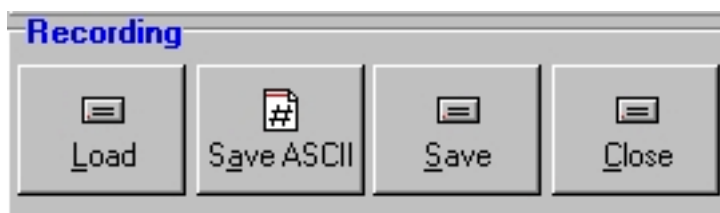

The recorded data may be stored in two formats:

- a) As ASCII file
- b) As recorder file

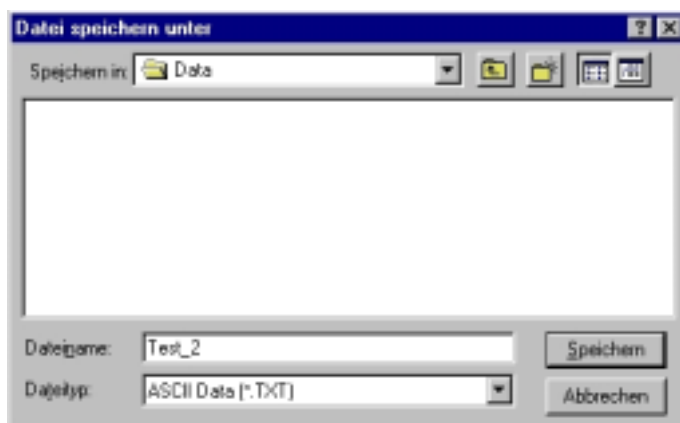

The recorder file can later be loaded into the recorder again.

Using the "Load" and "Close" options, any available file can be loaded or closed again.

## 8.7. Messages Page

On the Messages page [F3 Messages] the status of the program and the connected BINOS E instrument is shown.

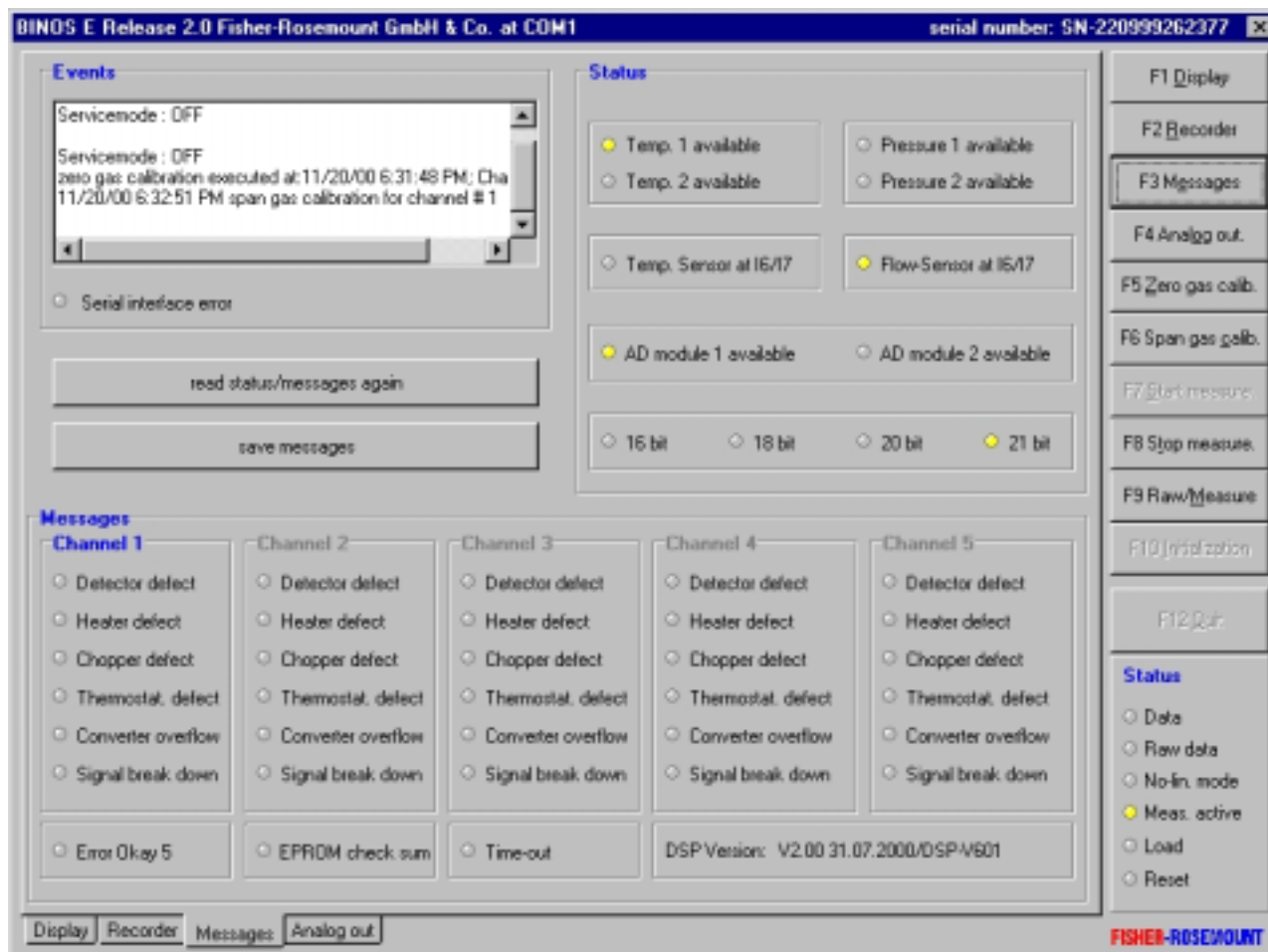

### Events:

On the upper left side an error report (failures, messages) is recorded which also indicates the time and date.

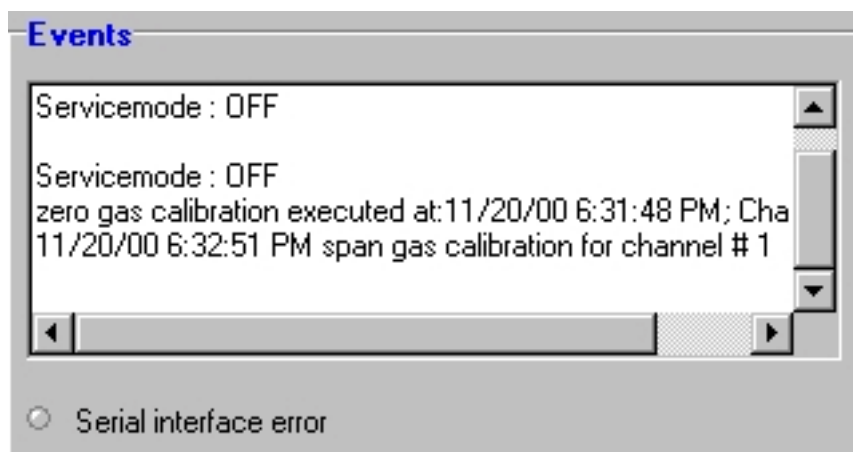

Zero or span gas calibration reports are shown reporting the adjusted channels. The failure (sum error) of a channel (signal) will be indicated as "unlock" while "locked" appears when the failure disappears.

Below this area a failure of the serial interface is shown via LED (illuminated in case or error).

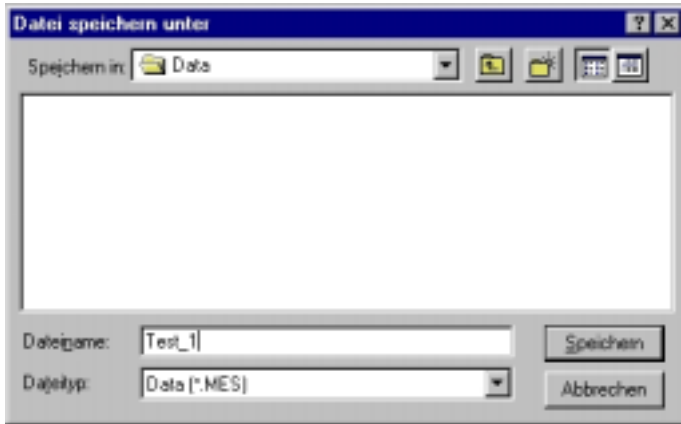

After that you can start the error report again with "read status/messages again". You can store the error reports into the directory "Data" with "save messages" before activating a new error report.

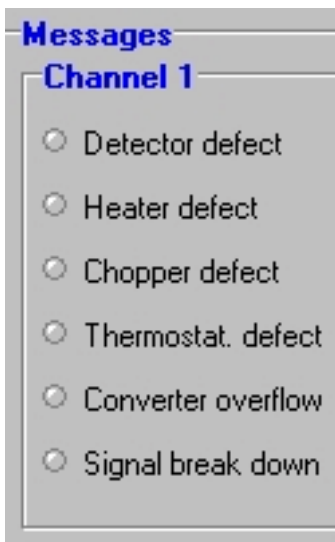

Detailed information to the failure messages are indicated under the category "Messages" in the lower area of this page. For each connected channel failure messages – split up in six areas - are indicated. In case of any failure the corresponding LED is illuminated.

In the expert level (Service has access) differentiated messages are available. Special messages for the Service are shown in the lowest part of this area (consult our Service Support Center).

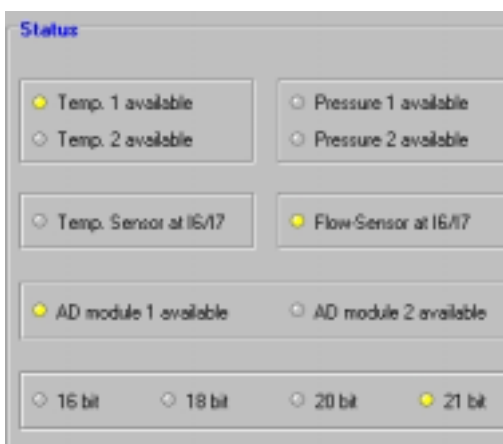
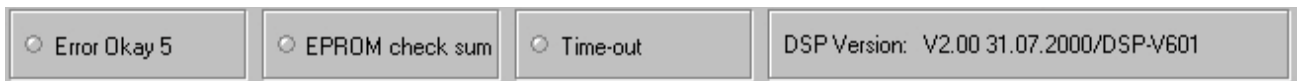

On the upper right side of this page, under "Status", is the hardware configuration of the BINOS E instrument showing the presence of the 6 defined or the 2 pairs of selectable optional sensors (signal sources). The availability of 1-2 temperature and 1-2 pressure sensors is indicated via LED (not possible for the 2 flow sensors). The display will also indicate whether the additional selectable pairs of sensors are temperature or flow sensors.

Beside this is information about the AD changers or transmission rates.

## 8.7. Analog Output Link and Adjustment Page

On the "Analog Output Link and Adjustment Page" [F4 Analog out.] the four optional analog outputs of a BINOS E analyzer can be linked to the respective channels or secondary parameters (sensors).

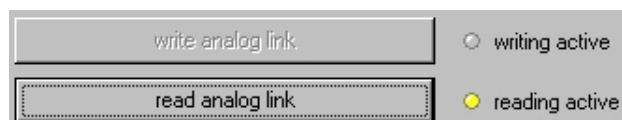
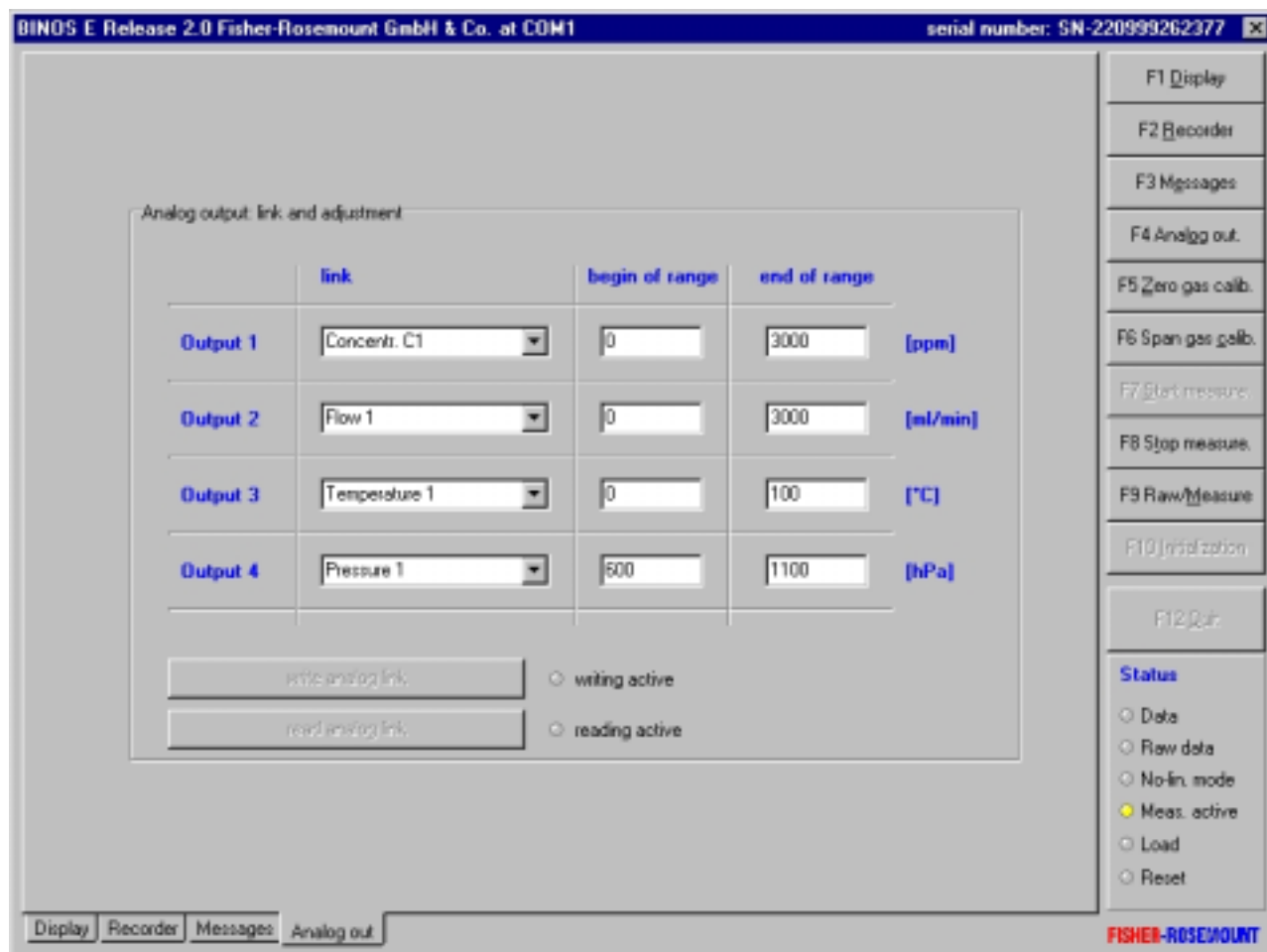

To view the actual settings, press the button "read analog link" (LED "reading active" is illuminated).



**ATTENTION:** Stop Measurement with F8 before adjustments can be performed!

Now new channel adjustments (concentration measurements) can be performed. Beside concentrations also secondary signal sources (temperature, pressure or flow) can be selected. Any "begin of range" or "end of range" can be set individually. The corresponding units are assigned automatically.



ATTENTION: Please remember that beside any customer settings, the specifications are valid only if the end of range is fixed between the ordered minimum and maximum end of range. Suppressed ranges (increased begin of range) must be indicated in the purchase order as well.

Output 2	Flow 1	0	3000	[ml/min]
Output 3	Temperature 1	0	100	[°C]
Output 4	Pressure 1	600	1100	[hPa]

The default settings from factory may not go conform with the secondary sensor properties. Please adjust according to your needs.

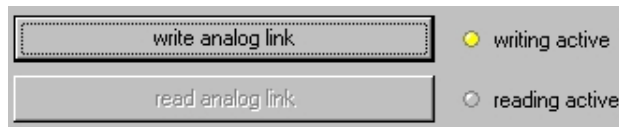

To store the changed adjustments the button "write analog link" has to be activated (LED "writing active" is illuminated).



## 9. BINOS E Data Exchange

BINOS E analyzer is equipped with a serial interface enabling communication with a host computer.

Alternatively to the BINOS E Front Panel Program user may create their own programs referring to the BINOS E data exchange via RS 232 interface.

The Digital Signal Processor (DSP) is sending periodically a data block (30 ms multiplied with the adjusted average time). The host computer can send commands to the DSP during reading to prescribe or alter parameters as well as initiate analyzer operations, using a standardized protocol.

The parameters for data exchange and the syntax of the telegrams to be established in protocols are available on request - consult factory.





### 13. Maintenance

In general only the gas conditioning hardware (sample handling system) will require maintenance.

The analyzer itself requires very little maintenance.

The following checks are recommended for maintenance of the proper operation of the analyzer.



Check and adjust zero level:  
 (low concentrations:

weekly  
 daily)



Check and adjust span:

weekly



Perform leak testing:

6 times annually.

The maintenance frequencies stated above are presented as guidelines only; maintenance operations may be required more or less frequently, depending upon usage and site conditions.



## 14. Leak Testing



Testing for gas leakage should be performed at bimonthly intervals and always immediately after any repair or replacement of gas - line components is performed. The test procedure is as follows:

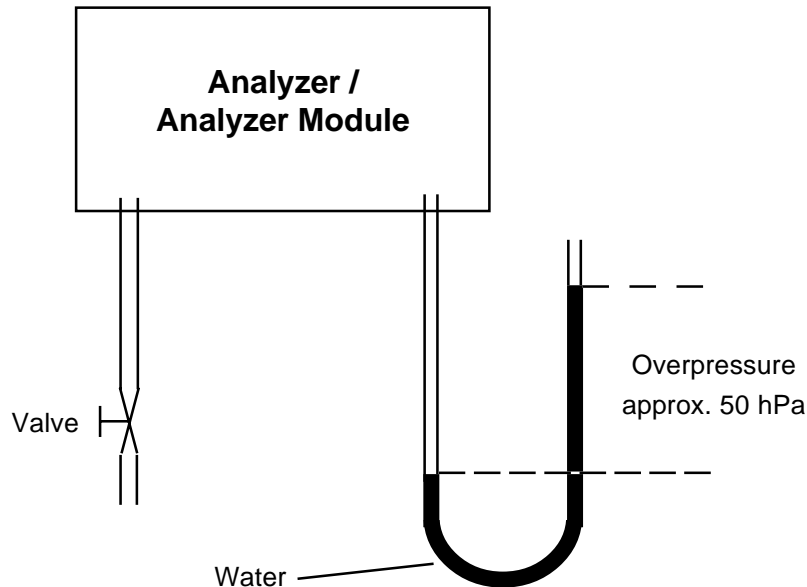

*Fig. 14-1: Leak Testing with an U - Tube - Manometer*

- Install a water - filled U - tube manometer at the sample gas outlet;
- Install a shut-off valve at the sample gas inlet.  
Admit air into the instrument at the shut-off valve until the entire analyzer is subjected to an overpressure of 50 hPa (approximately 500 mm water column; see Fig. 14-1).

Close the shut-off valve and verify that following a brief period required for pressure equilibrium, that the height of the water column does not drop over a period of about 5 minutes. Any external devices, such as sample gas cooling hardware, dust filters etc., should be checked in the course of leak testing.

Overpressure max. 500 hPa !



For differential measurement the leakage check must be performed for measurement side and reference side separately !

For analyzers with parallel gas paths the leakage check must be performed for each gas path separately !



## 15. Opening the Housing

The housing must be opened for checking the electrical connections and for replacement or cleaning of any of the components of the analyzer.



Be sure to observe Item 6. of the safety measures !

### 15.1 BINOS E (Sheet-metal housing)

#### 15.1.1 Housing Cover

- Disconnect all voltage supplies.
- Unscrew the respective fastening screws at both housing sides (Fig. 15-1).
- For rear cover unscrew the additional fastening screw at the top of the housing (Fig. 15-1)
- Remove the respective housing top cover panel.

Closing of the housing is performed in reverse order.

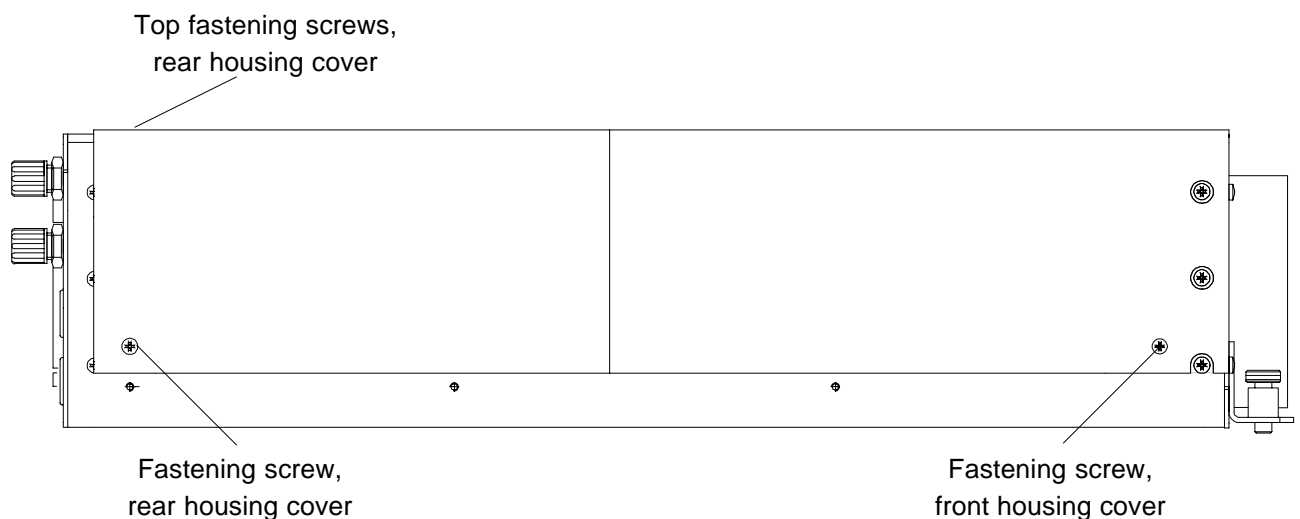

**Fig. 15-1: BINOS E, Metal-sheet housing**  
*(Fastening screws housing cover)*

## 15.2 BINOS E (1/2 19" housing)

### 15.2.1 Housing Cover

- Disconnect all voltage supplies.
- Unscrew fastening screws for rack-mounting / front frame if necessary (Fig. 1-1). Remove analyzer out of rack or remove the front mounting frame and carrying strap to rear.
- Unscrew the respective fastening screws at both housing sides (Fig. 15-2)
- Remove the respective housing top cover panel.

Closing of the housing is performed in reverse order.

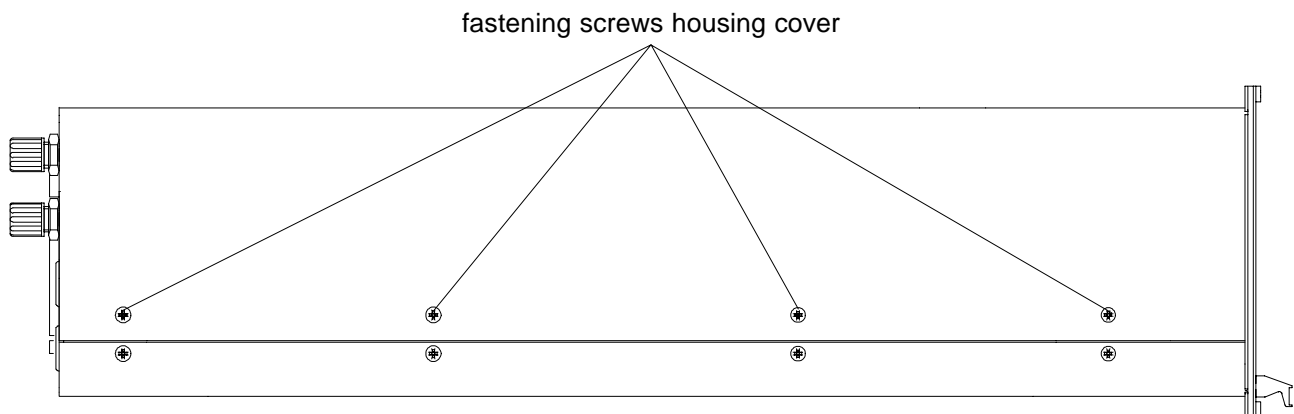

**Fig. 15-2: BINOS E (1/2 19" housing)**  
(Fastening screws housing cover)

## 17. Replacement and Cleaning of Photometric Components

The housing has to be opened for checking the electrical connections and for replacement or cleaning of any of the components of the equipment.



Be sure to observe the safety measures, Item 5. and 6. especially !

### 17.1 Removal of the Photometer Assembly

- Open the housing (cf. Section 15).
- Disconnect all electrical connections between photometer assembly and electronic unit (pcb PIC or DSP) and remove all gas lines from the photometer assembly if necessary.
- Unscrew both the hexagonal screws shown in Fig. 17-1.



Depending on photometer or analyzer/analyzer module there could be exist hot components !

- Remove the photometer assembly to top of analyzer housing as a unit.

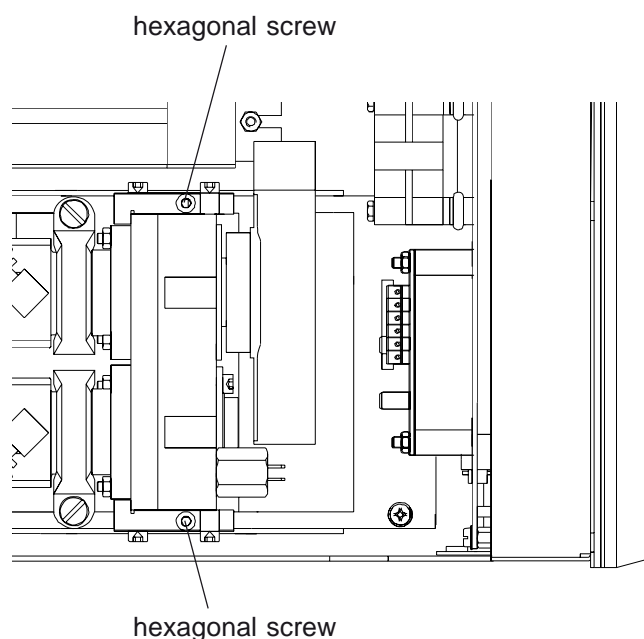

**Fig. 17-1: Photometer Assembly, example**  
 (Top view, detail)

## 17.2 Light Source Replacement (IR)

- Open the housing (cf. Section 15).
- Remove the photometer assembly out of analyzer housing (see Section 17.1).
- Remove the two light source hexagonal mounting screws (shown in Fig. 17-2 as Item 1).
- Remove the light source together with its mounting flange.
- Remove the mounting flange from the light source and position it on the new light source.
- Insert the new light source and flange in the same position as the old one.
- Insert and tighten the two light source hexagonal mounting screws (Fig. 17-2).

Then:

- Replace the photometer assembly (see Section 17.4).
- Perform the physical zeroing procedure (see Section 17.5).

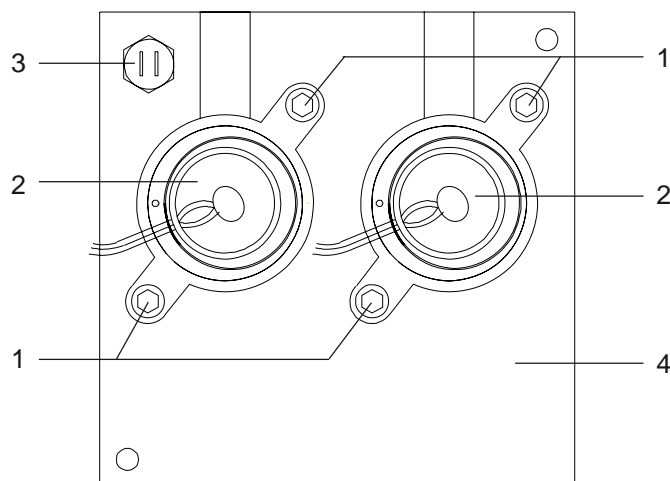

**Fig. 17-2: Chopper Housing with IR light sources**

- 1 Light source hexagonal mounting screw
- 2 Light source with mounting flange
- 3 Temperature sensor (older versions)
- 4 Chopper Housing



## 17.3 Cleaning of Analysis Cells and Windows

### 17.3.1 Removal of Analysis Cells

- Open the housing (cf. Section 15).
- Remove the photometer assembly out of analyzer housing (see Section 17.1).
- a) For analysis cells of lengths 1 mm to 10 mm
  - Remove the clamp (Fig. 17-3, Item 1).
  - Remove the clamping collars and the filter cell with signal detector assembly.

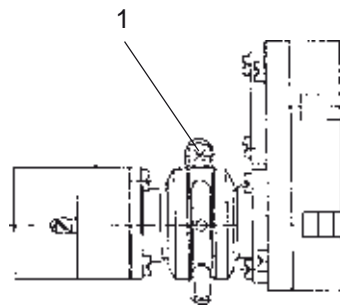

**Fig. 17-3: Photometer Assembly (1 mm to 10 mm analysis cells)**

- b) For analysis cells of lengths 30 mm to 200 mm:
  - Remove the clamp shown in Fig. 17-4 as Item 1.
  - Remove the filter cell with signal detector assembly.
  - Remove the clamp shown in Fig. 17-4 as Item 2.
  - Remove the analysis cell body from the filter cell (chopper housing).

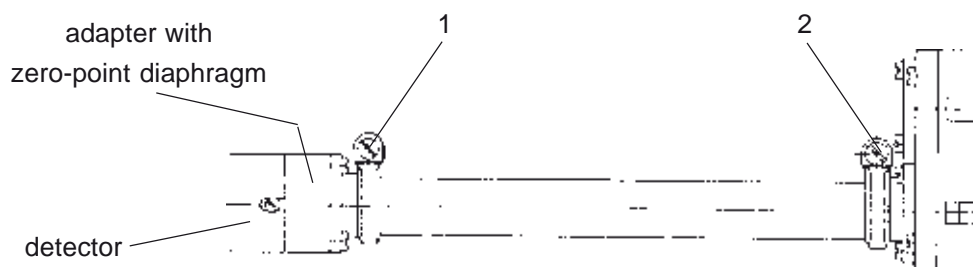

**Fig. 17-4: Photometer Assembly (30 mm to 200 mm analysis cells)**

### 17.3.2 Cleaning

#### a) Windows

The shielding windows (on the filter cells, chopper housing and the analysis cell) may be cleaned with a soft, fluff free cloth.

Use a highly volatile alcohol for the cleaning procedure.

To remove any lint and dust particles remaining, blow off the cleaned components with nitrogen ( $N_2$ ).

#### b) non-divided analysis cells

The analysis cell may be cleaned with a soft, fluff free cloth.

Use a highly volatile alcohol for the cleaning procedure.

To remove any lint and dust particles remaining, blow off analysis cell with nitrogen ( $N_2$ ).

#### c) divided analysis cells

If deposits are visible in the analysis cell, these can be removed with suitable solvents e. g. acetone or spirit. Then the analysis cell is to be flushed with an alcohol which evaporates easily and dried by blowing nitrogen ( $N_2$ ).



Maxi. pressure in analysis cell 1.500 hPa !

### 17.3.3 Reinstalling of Analysis Cells

- a) For analysis cells of lengths 1 mm and 7 mm
- Place the O - rings on the filter cells.
  - Fit the components together and fix with the clamping collars.
  - Install the clamp (Fig. 17-3, Item 1) and tighten.
- b) Analysis cells of lengths 50 mm - 200 mm:
- Place the O - ring on the chopper housing side of the cell body.
  - Position the cell body in place and fasten using the clamp shown in Fig. 17-4 as Item 2.
  - Place the O - ring on the filter cell (with detector).
  - Fit the filter cell on the cell body.
  - Install the clamp shown in Fig. 17-4 as Item 1 and tighten.

Then:

- Replace the photometer assembly (see Section 17.4).

#### 17.4 Reinstalling of the Photometer Assembly

- Insert the photometer assembly into the analyzer housing and fasten in position using the hexagonal screws shown in Fig. 17-1.
- Reconnect all gas lines to the assembly.
- Reconnect all electrical connections between the photometer assembly and the electronic unit pcb PIC or DSP (see Section 1.3.2).
- Perform a leakage test (see Section 14).
- Perform the physical zeroing procedure (see Section 17.5).

## 17.5 Physical Zeroing

Adjustment of the physical zero - level will only be required if a light source, a filter cell, or an analysis cell have been replaced or repositionned.



Be sure to observe the safety measures !

Needed for the adjustment is a 3 mm hexagon wrench SW 3.

- Switch on the analyzer (cf. Section 6.).
- Admit zero gas to the instrument.
- Slightly loosen the light source mounting screws (shown in Fig. 17-2 as Item 1) for corresponding channel.
- Set the raw signal [(press "Status" (F2) ⇒ "RawMeas." (F2))] precisely to  $\pm 100.000$  counts by turning the corresponding light source.
- Tighten the light source mounting screws (shown in Fig. 17-2 as Item 1) for corresponding channel.

If the turning of the light source is not sufficient, the zero point can be adjusted by sliding the zero point diaphragm at the lower side of the detectors adapter (Fig. 17-4).

When the physical zeroing has been correctly set, perform an electrical zeroing (see software manual).



## 18. Check / Replacement of electrochemical Oxygen Sensor

Through measuring principle the oxygen sensor will have only a limited life time.

The life time of the oxygen sensor is depending on the sensor itself and on the measured oxygen concentration and is calculated as follows:

$$\text{life time} = \frac{\text{sensor time (hours)}}{\text{O}_2 \text{ concentration (\%)}}$$

The so-called "sensor time" (operation without oxygen at 20 °C ) is

approx. 900.000 hours for sensor with a response time of about 12 s

The sensors will have the following life time at approx. 21 % Oxygen and 20 °C :

approx. 42.857 hours (approx. 5 years) for sensor with a response time of about 12 s

### Note !

The values stated above are presented as guidelines only. The values are depending on operation temperatures (the result of higher temperatures, for example 40 °C, could be the half life time) and measured concentrations.

### Note !

Depending on measuring principle the electrochemical O<sub>2</sub> cell needs a minimum internal consumption of oxygen (residual humidity avoids drying of the cell). Supply cells continuously with dry sample gas of low grade oxygen concentration or with oxygenfree sample gas could result a reversible detuning of O<sub>2</sub> sensitivity. The output signal will become unstable.

For correct measurement the cells have to be supplied with O<sub>2</sub> concentrations of at least 0.1 Vol.-%. We recommend to use the cells in intervall measurement (purge cells with conditioned (dust removal but no drying) ambient air during measurement breaks).

If it is necessary to interrupt oxygen supply for several hours or days, the cell has to regenerate (supply cell for about one day with ambient air). Temporary flushing with nitrogen (N<sub>2</sub>) for less than 1 h (e.g. analyzer zeroing) will have no influence to measuring value.

All analyzers with electrochemical O<sub>2</sub> cell have to be purged with conditioned ambient air prior to disconnect the gas lines ! Then the gas line fittings have to be closed for transport or depositing analyzer.

## 18.1 Check of the Sensor



Exchange the sensor, if the voltage is less than 70 % of the initially output voltage.

The check requires a digital voltmeter (DVM) with a range of 2 V DC.

- Remove front panel (see 15.).
- Switch on the analyzer (see Section 6.).
- Admit ambient air to the analyzer (approx. 21 Vol. - O<sub>2</sub>).
- Connect the DVM to the measuring points

Tp 1 (Signal) and Tp 2 ( ⊥ ) of the PCB OXS, mounted directly at the connection block (Fig. 18-1, see also Fig. 18-2, 1-3, 1-16a and 1-17).

The measuring signal should be into a range of 700 mV DC to 1000 mV DC.

### Note !

If the measuring value is lower than 700 mV at gas flow with ambient air, the sensor is consumed.

Exchange the sensor.

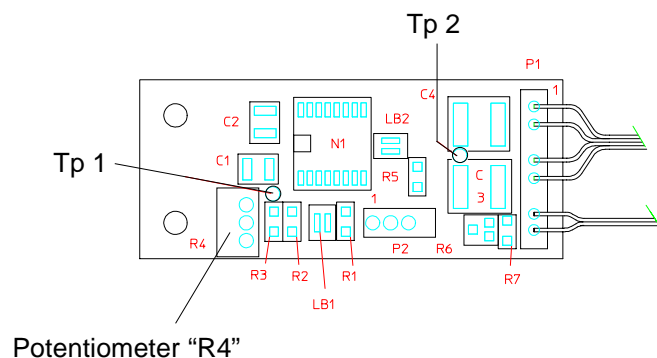

**Fig. 18-1: PCB "OXS", assembled, horizontal projection**



## 18.2 Replacement of the Sensor



Be sure to observe the safety measures !

### 18.2.1 Removal of the Sensor

- Remove front panel (see Item 15.).
- Remove the fastening hexagon nuts of the connection block (Fig. 18-2) with hexagon spanner (SW 5.5) and remove connection block including oxygen sensor from front panel.

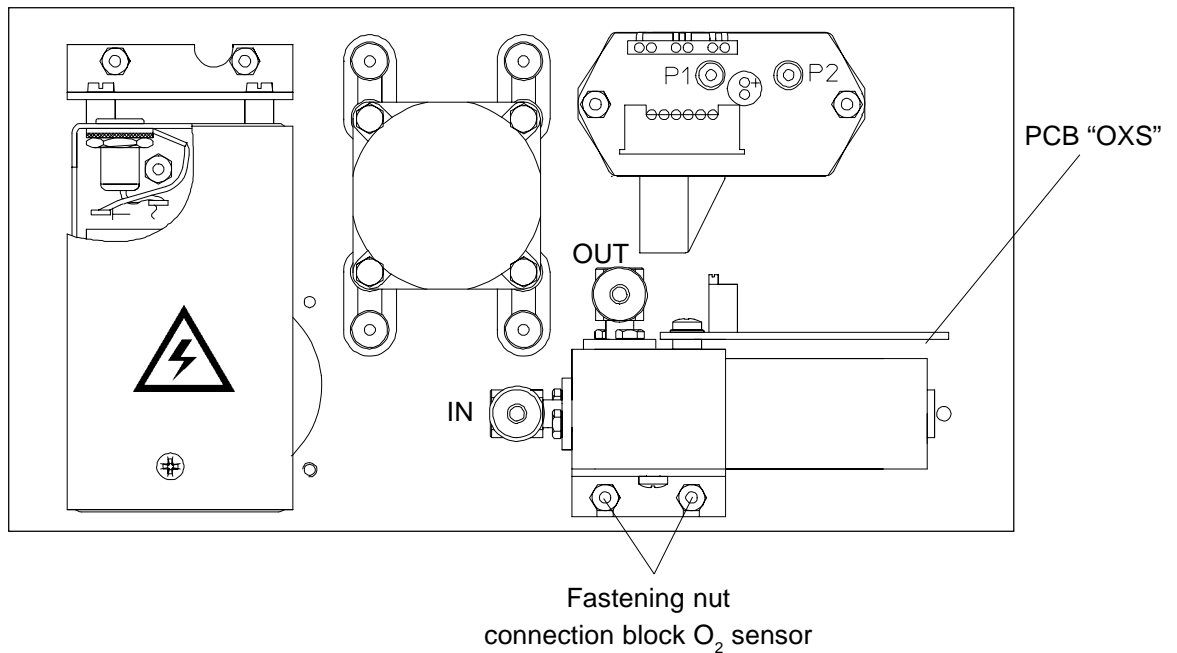

**Fig. 18-2: BINOS E, front panel, rear view**

### 18.2.2 Replacing the Sensor

- Disconnect the connector for the sensor from “P2” of circuit board “OXS” (see Fig. 18-3).
- Take the consumed sensor out of the fitting.
- Take off the stopper from new sensor and fit in the new sensor into the fitting, so that the name plate is at the top of the sensor.
- Connect the connector for the sensor to “P2” of circuit board “OXS” (see Fig. 18-3).
- Close the spent sensor with the stopper and dispose in accordance with respective legislation or send it to our factory alternatively.

### 18.2.3 Reinstalling of the Sensor

- Put connection block with the (new) sensor onto the front panel and screw the fastening hexagon nuts of the connection block (Fig. 18-2) with hexagon spanner (SW 5.5).
- Perform a leakage test (see Section 14.) and set the sensor (see Section 18.2.4).

### 18.2.4 Basic conditions for the Oxygen Sensor



- Admit ambient air for the analyzer (approx. 21 Vol. - O<sub>2</sub>) and switch on (see Section 6.).
- Connect the DVM to the measuring points

Tp 1 (Signal) and Tp 2 ( ⊥ ) of the PCB OXS, mounted directly at the sensor block (Fig. 18-1, see also Fig. 18-2, 1-3, 1-16a and 1-17).

- Set the signal to 1000 mV DC (± 5 mV) with potentiometer R4 (Fig. 18-3) of the corresponding circuit board "OXS".

**Note !**

It is not allowed to change this setting for this sensor again !

- Switch off the analyzer and close the analyzer housing (see 15.).  
 Built-in the module into platform if necessary.
- A complete re-calibration of the instrument must be performed after a sensor replacement.

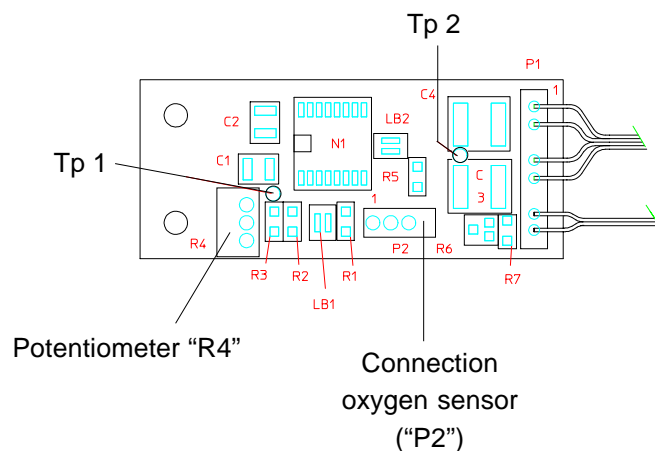

**Fig. 18-3: PCB "OXS", assembled, horizontal projection**



## 19. Cleaning of Housing Outside

For cleaning of BINOS E housing outside, you need a soft, fluff free cloth and all purpose detergent.

- Disconnect all voltage supplies.

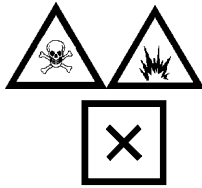

To avoid a danger to the operators by explosive, toxic or unhealthy gas components, first purge the gas lines with ambient air or nitrogen (N<sub>2</sub>) before cleaning or exchange parts of the gas paths.



If it is necessary to disconnect the gas connections, the gas line fittings of the BINOS E have to be closed with PVC caps before cleaning !

- Moisten of the soft, lint-free cloth with the cleaning solution (mixture of 3 parts water, 1 part all purpose detergent max.).



Be sure to use a damped, but not wet, cloth only !  
 Be sure, that non liquid can drop into the housing inside !

- Cleaning of the BINOS E housing outside with the damped cloth.
- If required, rub off the housing, but not the front panel, with a dry cloth afterwards.



## 20. Technical Data

### Certifications

(for measurement of not flammable gases or not explosive gases resp. (< 50 % LEL).

Bigger concentrations requires supplementary protective measures !)

**CE** EN 50081-1, EN 50082-2, EN 61010-1

### 20.1 Housing

#### Gas connections

(Sample gas/ Reference gas / Purge gas)  
 Standard 6/4 mm PVDF  
 Option: 6/4 mm or 1/4", ss  
 additional fittings on request  
 max. 8 fittings

#### Housing dimensions

see dimensional sketches (Fig. 20-1)

#### Weight (depending on configuration)

approx. 8 - 13 kg

#### Protection class

IP 20 (according to DIN standard 40050)

#### Permissible ambient temperature (operation)

+ 5 °C to + 40 °C  
 (higher ambient temperatures on request:  
 +5 °C to + 45 °C to be delivered, except of EO<sub>2</sub>)

#### Permissible storage temperature

- 20 °C to + 70 °C

#### Humidity (non condensing)

< 90 % rel. humidity at + 20 °C  
 < 70 % rel. humidity at + 40 °C

#### Rain / Drop and splash water

The BINOS E must not be exposed to rain or drop/splash water

#### Explosive atmosphere

The BINOS E must not be operated in explosive atmosphere without supplementary protective measures

Ventilation Free flow of air into and out of the BINOS E (ventilation slits) must not be hindered by nearby objects or walls !

Altitude 0 - 2000 m (above sea level)

## 20.2 Options

Pressure sensor Measuring range: 800 - 1,100 hPa

Flow sensor Measuring range: 0 - 2,000 cc/min.  
(higher flow rates may destroy the flow sensor!)

## 20.3 General Specifications

Measuring components see order confirmation

Measuring ranges

NDIR/VIS/UV see order confirmation

paramagnetic oxygen sensor ( $PO_2$ )<sup>1)</sup> 0 - 5 % to 0 - 100 %  $O_2$  or  
0 - 2 % to 0 - 25 %  $O_2$   
0 - 1 % to 0 - 10 %  $O_2$ <sup>2)</sup>

electrochemical oxygen sensor ( $EO_2$ ) 0 - 5 %  $O_2$  to 0 - 25 %  $O_2$ <sup>3)</sup>

- 1) Solvent-resistant or corrosion-resistant or internally intrinsically safe oxygen cells are available (KEMA Ex-97.E.4993 U, consult factory).
- 2) Non-standard range with non-standard specifications, see BINOS E specifications
- 3) Higher measuring ranges and higher ambient temperature reduce sensor lifetime!



**20.3.1 BINOS E Specifications:**

<b>Table 20-1</b>	<b>NDIR / VIS / UV</b>	<b>Oxygen Sensor (PO<sub>2</sub> and EO<sub>2</sub>)</b>	<b>PO<sub>2</sub>, special range: 0 - 1 Vol.-%</b>
<b>Detection limit</b>	≤ 1 % <sup>1) 4)</sup>	≤ 1 % <sup>1) 4)</sup>	≤ 2 % <sup>1) 4)</sup>
<b>Linearity</b>	≤ 1 % <sup>1) 4)</sup>	≤ 1 % <sup>1) 4)</sup>	≤ 2 % <sup>1) 4)</sup>
<b>Zero-point drift</b>	≤ 2 % per week <sup>1) 4)</sup>	≤ 1 % per week <sup>1) 4)</sup>	≤ 2 % per week <sup>1) 4)</sup>
<b>Span (sensitivity) drift</b>	≤ 0.5 % per week <sup>1) 4)</sup>	≤ 2 % per week <sup>1)</sup>	≤ 4 % per week <sup>1)</sup>
<b>Repeatability</b>	≤ 1 % <sup>1) 4)</sup>	≤ 1 % <sup>1) 4)</sup>	≤ 2 % <sup>1) 4)</sup>
<b>Response time (t<sub>90</sub>)</b>	3 s ≤ t <sub>90</sub> ≤ 7 s <sup>3) 5)</sup>	< 3 s (increasing) <sup>3) 6)</sup> < 4 s (decreasing) <sup>3) 6)</sup> approx. 12 s <sup>3) 13)</sup>	< 3 s (increasing) <sup>3) 6)</sup> < 4 s (decreasing) <sup>3) 6)</sup>
<b>Permissible gas flow</b>	0.2 - 1.5 l/min	0.2 - 1.0 l/min <sup>6)</sup> 0.2 - 1.5 l/min <sup>13)</sup>	0.2 - 1.0 l/min <sup>6)</sup>
<b>Influence of gas flow</b>		≤ 2 % <sup>1) 4)</sup>	≤ 2 % <sup>1) 4)</sup>
<b>Permissible pressure</b>	≤ 1,500 hPa abs.	atm. pressure <sup>6)</sup> ≤ 1,500 hPa abs. <sup>13)</sup>	atm. pressure <sup>6)</sup>
<b>Influence of pressure</b> (at constant temperature) (with pressure compensation) <sup>8)</sup>	≤ 0.10 % per hPa <sup>2)</sup> ≤ 0.01 % per hPa <sup>2)</sup>	≤ 0.10 % per hPa <sup>2)</sup> ≤ 0.01 % per hPa <sup>2)</sup>	≤ 0.10 % per hPa <sup>2)</sup> ≤ 0.01 % per hPa <sup>2)</sup>
<b>Influence of temperature</b> (at constant pressure) - on zero point - on span (sensitivity)	≤ 1 % per 10 K <sup>1)</sup> ± 5 % (+5 to +40 °C) <sup>1) 11)</sup>	≤ 1 % per 10 K <sup>1)</sup> ≤ 1 % per 10 K <sup>1)</sup>	≤ 2 % per 10 K <sup>1)</sup> ≤ 2 % per 10 K <sup>1)</sup>
<b>Thermostat Control</b>	none <sup>13)</sup>	approx. 55 °C <sup>6) 10)</sup>	approx. 55 °C <sup>6) 10)</sup>
<b>Warm-up time</b>	approx. 15 to 50 minutes <sup>5)</sup>	approx. 50 minutes	approx. 50 minutes

- 1) related to full scale
- 2) related to measuring value
- 3) from analyzer gas inlet at gas flow of approx. 1.0 l/min.  
(electrical = 2 s)
- 4) constant pressure and temperature
- 5) dependent on integrated photometer bench / sensor
- 6) paramagnetic oxygen measurement (PO<sub>2</sub>)

- 7) depending on sensor position
- 8) optional pressure sensor is required
- 10) thermostat controlled PO<sub>2</sub> sensor
- 11) starting from +20 °C (to +5 °C or to +40 °C)
- 12) sensor / cell only
- 13) electrochemical oxygen measurement (EO<sub>2</sub>)

### 20.3.2 Cross sensitivities

Electrochemical oxygen measurement      Not for use with sample gases containing FCHC's,  
inorganic gases with chlorine and fluorine !  
Not for ozone, H<sub>2</sub>S (> 100 ppm), NH<sub>3</sub> (> 20 ppm)!

Paramagnetic oxygen measurement

100 % Gas	zero-level effect [% O <sub>2</sub> ]
N <sub>2</sub>	0,00
CO <sub>2</sub>	- 0,27
H <sub>2</sub>	+ 0,24
Ar	- 0,22
Ne	+ 0,13
He	+ 0,30
CO	+ 0,01
CH <sub>4</sub>	- 0,20
C <sub>2</sub> H <sub>6</sub>	- 0,46
C <sub>2</sub> H <sub>4</sub>	- 0,26
C <sub>3</sub> H <sub>8</sub>	- 0,86
C <sub>3</sub> H <sub>6</sub>	- 0,55
NO	+ 43,0
NO <sub>2</sub>	+ 28,0
N <sub>2</sub> O	- 0,20

**20.3.3 Dimensions**

**BINOS E: Sheet-metal housing**

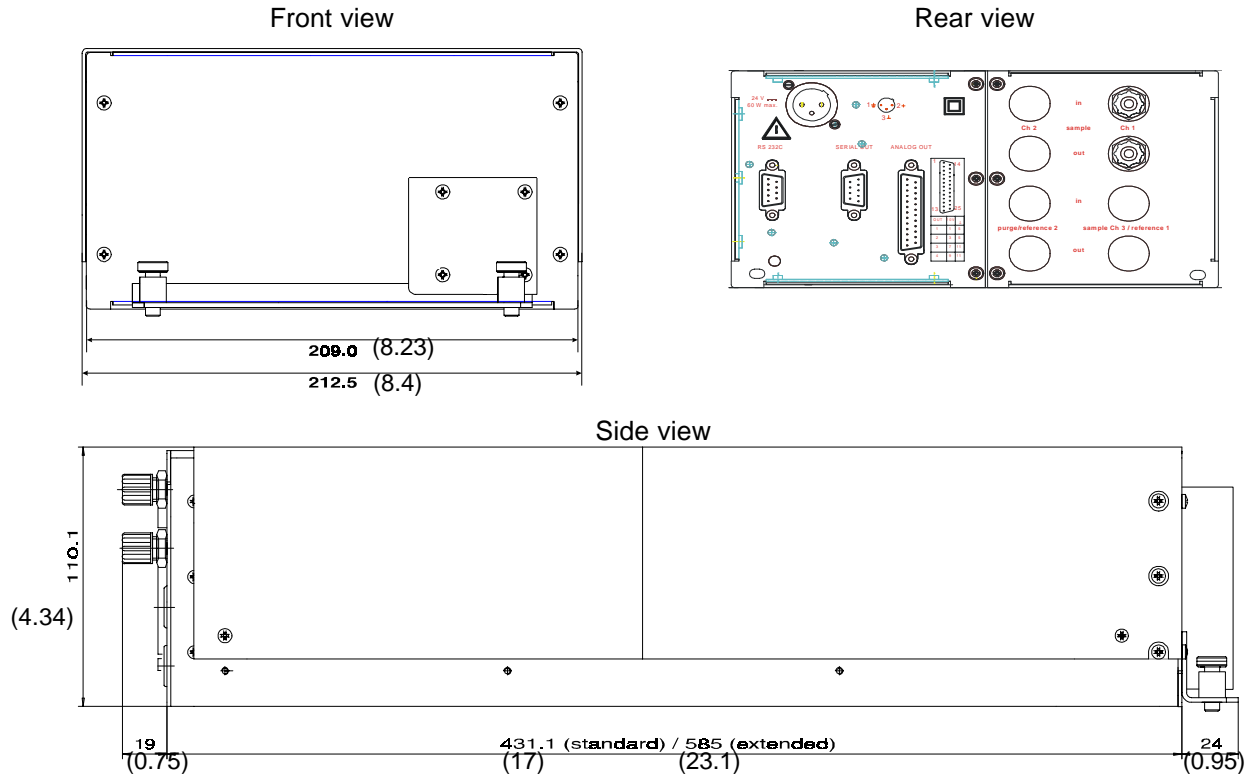

**BINOS E: Rack-mounting / table-top housing**

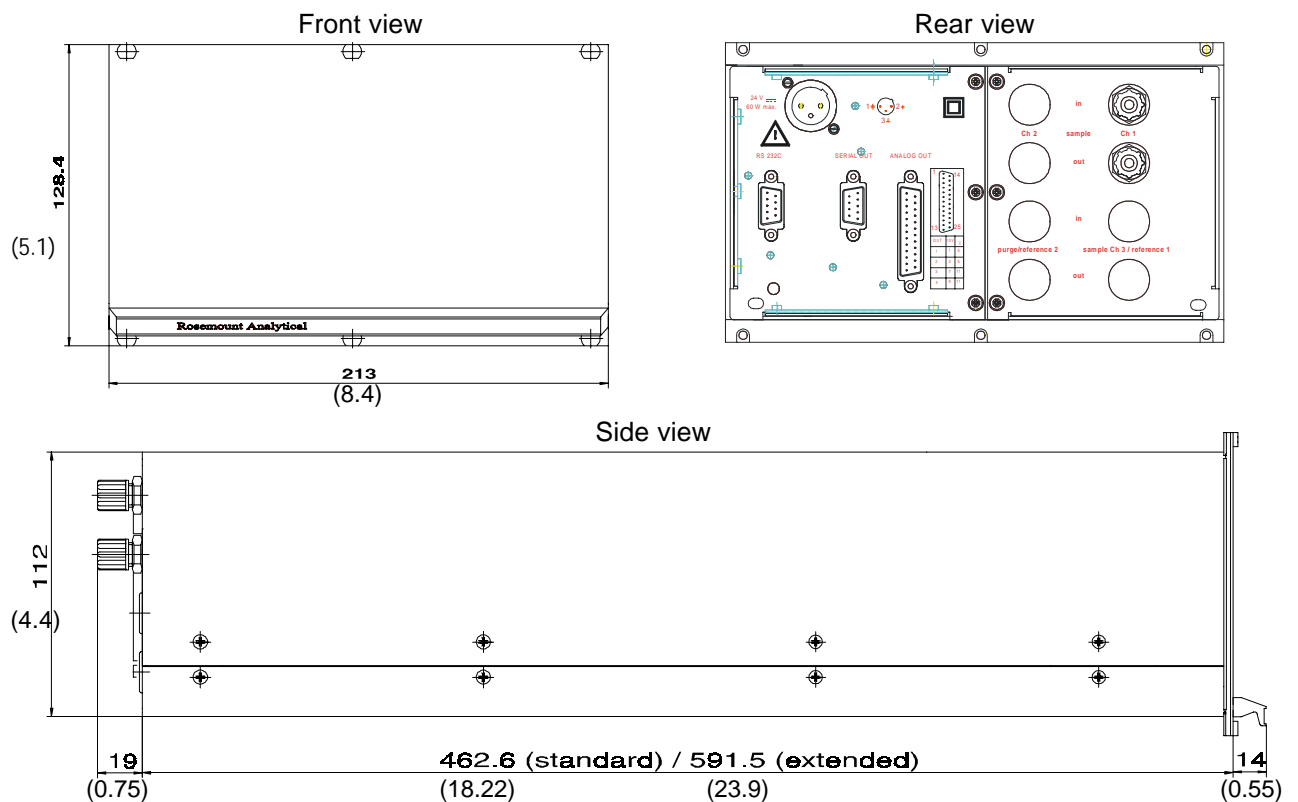

**Fig. 20-1: Dimensional sketch BINOS E [all dimensions in mm, inches in parentheses]**

## 20.4 Voltage supply

Input	3-pole XLR- Flange (male), lockable
Voltage Supply	24 V dc (+/- 5 %) / 3 A
[For ac operation {230/120 V}]	dc supply by options SL10, SL5 (both for rack mounting only) UPS 01 T, or equivalent power supply]

### 20.4.1 Electrical Safety

Over-voltage category	II
Pollution degree	2
Safety Class	2 (□)
all I/O's	SELV voltage optically isolated to electrical supply

### 20.4.2 Power Supplies [UPS 01 T (Universal Power Supply) / SL10 / SL5]

Input (UPS/SL10/SL5)	plug / terminal strips / <i>terminal strips</i>
Nominal voltage	230 / 120 V ac, 50 / 60 Hz
Input voltage	196–264 V ac and 93–132 V ac, 47-63 Hz
UPS / SL10 or SL5	with autoranging / manual switch
Input power	
UPS or SL5 / SL10	max. 240 VA / <i>max. 700 VA</i>
Fuses UPS (internal)	T 3.15A/250V (2 pcs.)
Output	3-poliger XLR- Flange (female) (UPS) / terminal strips (SL10 / SL5)
Output voltage	24 V dc
UPS / SL10 / SL5	max. 5.0 A / max. 10.0 A / <i>max. 5.0 A</i>
Output power	
UPS / SL10 / SL5	max. 120 VA / max. 240 VA / <i>max. 120 VA</i>
Dimensions	
UPS Rack module	19" 3 HU, 21 DU
Installation depth (with plug / cable)	min. 400 mm
UPS table-top module	see Fig. 20-11
SL5 (mountable on DIN supporting rails TS35)	125 x 65 x 103 mm (HxWxD), see Fig. 20-9 and 20-10
SL10 (mountable on DIN supporting rails TS35)	125 x 122 x 103 mm (HxWxD), see Fig. 20-8 and 20-10

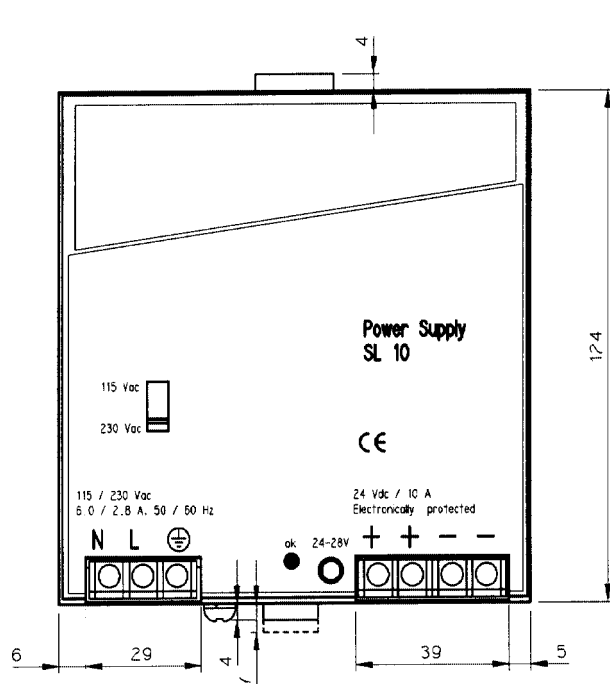

**Fig. 20-8:**  
**Dimensional sketch SL10 (Front view) [mm]**

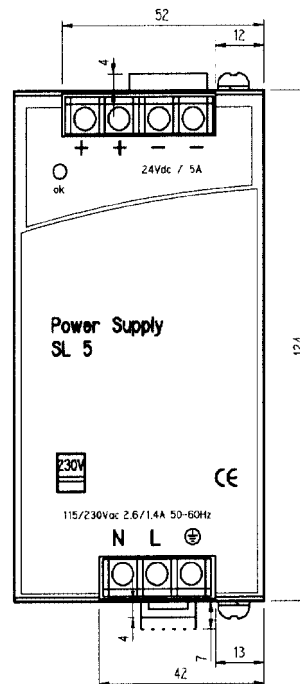

**Fig. 20-9:**  
**Front view SL 5**

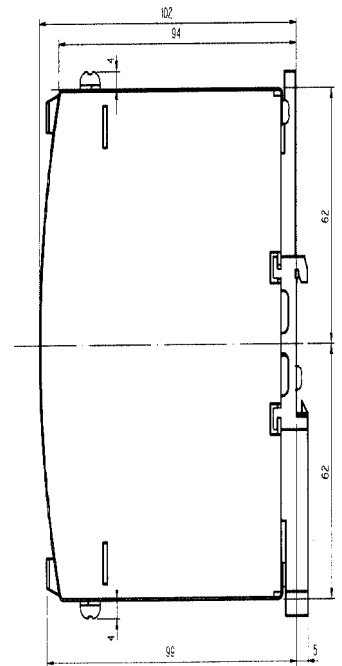

**Fig. 20-10:**  
**Side view SL10/SL5**

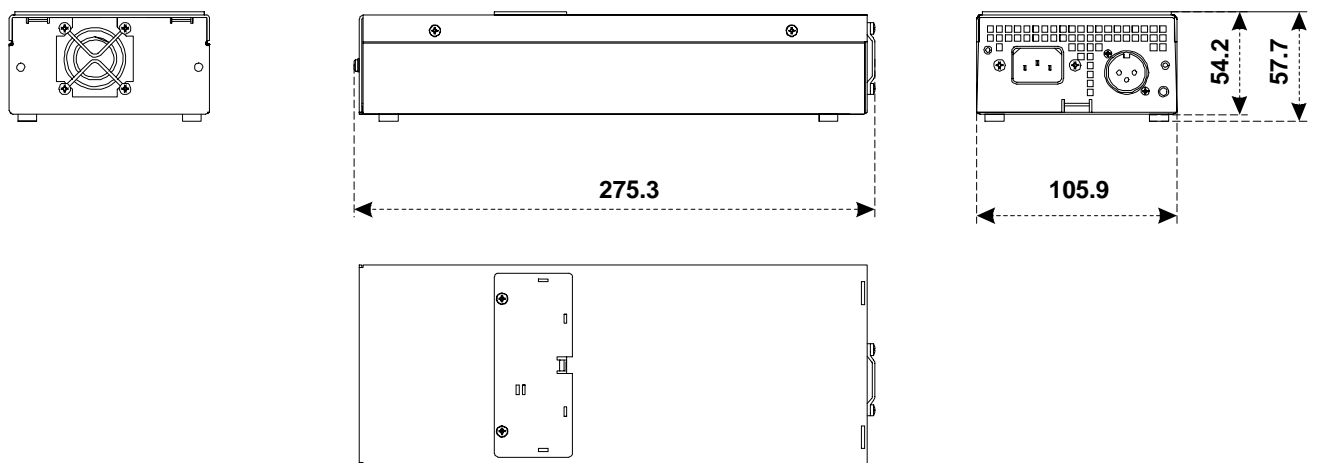

**Fig. 20-11: Dimensional sketch UPS 01 T (Universal Power Supply), table-top version**  
**rack module turn around 90° [all dimensions in mm, without cable and plugs]**



## 21. Pin Assignments

Use only from our factory optional delivered cables or equivalent shielded cables to be in agreement with the CE - conformity.



The customer has to guarantee, that the shield is be connected bothsided. Shield and connectors housing have to be connected conductive. Sub.-min.-D-plugs/sockets have to be screwed to the analyzer.

### 21.1 24 V dc Input

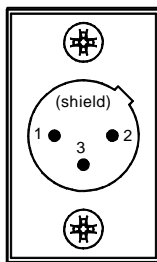

Supply  
from rear

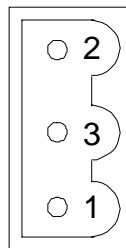

Supply from front  
(see Fig. 6-1, too)

Pin 1:	ME
Pin 2:	+ 24 V dc
Pin 3:	0 V DC ( $\perp$ )
shield:	housing flange

**Fig. 21-1: Pin assignments 24 V dc Input**





## 22. Calculation of Water Content from Dew-point to Vol. -% or g/Nm<sup>3</sup>

Table 22-1

Dew-point		Water Content	Water Concentration
° C	° F	Vol. -%	g/Nm <sup>3</sup>
+ 0	+ 32,0	0,60	4,88
+ 1	+ 33,8	0,65	5,24
+ 2	+ 36,8	0,68	5,64
+ 3	+ 37,4	0,75	6,06
+ 4	+ 39,2	0,80	6,50
+ 5	+ 41,0	0,86	6,98
+ 6	+ 42,8	0,92	7,49
+ 7	+ 44,6	0,99	8,03
+ 8	+ 46,4	1,06	8,60
+ 9	+ 48,2	1,13	9,21
+ 10	+ 50,0	1,21	9,86
+ 11	+ 51,8	1,29	10,55
+ 12	+ 53,6	1,38	11,29
+ 13	+ 55,4	1,48	12,07
+ 14	+ 57,2	1,58	12,88
+ 15	+ 59,0	1,68	14,53
+ 16	+ 60,8	1,79	14,69
+ 17	+ 62,6	1,90	16,08
+ 18	+ 64,4	2,04	16,72
+ 19	+ 66,2	2,16	17,72
+ 20	+ 68,0	2,30	19,01
+ 21	+ 69,8	2,45	20,25
+ 22	+ 71,6	2,61	21,55
+ 23	+ 73,4	2,77	22,95
+ 24	+ 75,2	2,95	24,41
+ 25	+ 77,0	3,12	25,97
+ 26	+ 78,8	3,32	27,62
+ 27	+ 80,6	3,52	29,37
+ 28	+ 82,4	3,73	32,28
+ 29	+ 84,2	3,96	33,15
+ 30	+ 86,0	4,18	35,20
+ 31	+ 87,6	4,43	37,37
+ 32	+ 89,6	4,69	39,67
+ 33	+ 91,4	4,97	42,09
+ 34	+ 93,2	5,25	44,64
+ 35	+ 95,0	5,55	47,35
+ 36	+ 96,8	5,86	50,22
+ 37	+ 98,6	6,20	53,23
+ 38	+ 100,4	6,55	56,87
+ 39	+ 102,2	6,90	59,76
+ 40	+ 104,0	7,18	62,67

Dew-point		Water Content	Water Concentration
° C	° F	Vol. -%	g/Nm <sup>3</sup>
+ 42	+ 107,6	8,10	70,95
+ 44	+ 111,2	8,99	79,50
+ 45	+ 113,0	9,45	84,02
+ 46	+ 114,8	9,96	89,20
+ 48	+ 118,4	11,07	99,80
+ 50	+ 122,0	12,04	110,81
+ 52	+ 125,6	13,43	124,61
+ 54	+ 129,2	14,80	139,55
+ 55	+ 131,0	15,55	147,97
+ 56	+ 132,8	16,29	156,26
+ 58	+ 136,4	17,91	175,15
+ 60	+ 140,0	19,65	196,45
+ 62	+ 143,6	21,55	220,60
+ 64	+ 147,2	23,59	247,90
+ 66	+ 150,8	25,80	279,20
+ 68	+ 154,4	28,18	315,10
+ 70	+ 158,0	30,75	356,70
+ 72	+ 161,6	33,50	404,50
+ 74	+ 165,2	36,47	461,05
+ 76	+ 168,8	39,66	527,60
+ 78	+ 172,4	43,06	607,50
+ 80	+ 176,0	46,72	704,20
+ 82	+ 179,6	50,65	824,00
+ 84	+ 183,2	54,84	975,40
+ 86	+ 186,8	59,33	1171,50
+ 88	+ 190,4	64,09	1433,30
+ 90	+ 194,0	69,18	1805,00

Remark: Norm conditions are related to 273 K (0 °C) and 1013 hPa (mbar).

The water concentration is calculated under dry norm conditions which means after (fictive) subtraction of moisture content on water vapor.

**Instruction Manual**

ETC00303

02/2007

**BINOS<sup>®</sup> E**

---

**WORLD HEADQUARTERS  
ROSEMOUNT ANALYTICAL EUROPE**

**Emerson Process Management  
GmbH & Co. OHG**

Industriestrasse 1  
63594 Hasselroth  
Germany  
T 49 6055 884 0  
F 49 6055 884209

**Emerson Process Management  
Rosemount Analytical Inc.**

6565 P Davis Industrial Parkway  
Solon, OH 44139 USA  
T 440.914.1261  
Toll Free in US and Canada 800.433.6076  
F 440.914.1271  
e-mail: [gas.csc@EmersonProcess.com](mailto:gas.csc@EmersonProcess.com)  
[www.raihome.com](http://www.raihome.com)

**GAS CHROMATOGRAPHY CENTER  
AND LATIN AMERICA**

**Emerson Process Management  
Rosemount Analytical Inc.**

11100 Brittmoore Park Drive  
Houston, TX 77041  
T 713 467 6000  
F 713 827 3329

**EUROPE, MIDDLE EAST AND AFRICA**

**Emerson Process Management  
Shared Services Limited**

Heath Place  
Bognor Regis  
West Sussex PO22 9SH  
England  
T 44 1243 863121  
F 44 1243 845354

**ASIA-PACIFIC**

**Emerson Process Management  
Asia Pacific Private Limited**

1 Pandan Crescent  
Singapore 128461  
Republic of Singapore  
T 65 6 777 8211  
F 65 6 777 0947  
e-mail: [analytical@ap.emersonprocess.com](mailto:analytical@ap.emersonprocess.com)