

SEARS

owner's
manual

**MODEL NO.
247.886700**

CAUTION:

Read
INSTRUCTIONS
carefully

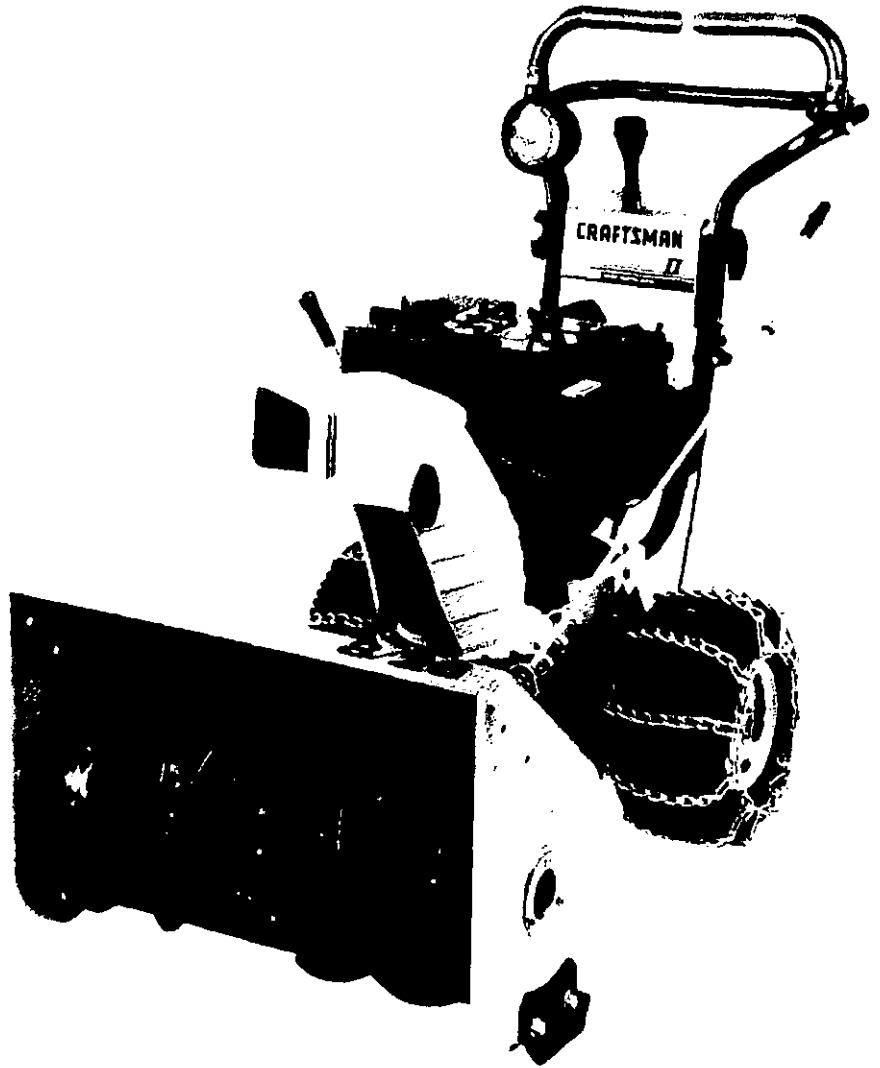

SEARS / CRAFTSMAN®

**26" - 8 H.P. DUAL STAGE
SNOW THROWER**
Optional Electric Starter Available

- Assembly
- Operation
- Maintenance
- Repair Parts

Sold by Sears, Roebuck and Co., Chicago, IL 60684

CRAFTSMAN WARRANTY

LIMITED TWO YEAR WARRANTY ON CRAFTSMAN SNOW THROWER

For two years from the date of purchase, when this **Craftsman Snow Thrower** is maintained, lubricated and tuned up according to the instructions in the owner's manual, Sears will repair, free of charge, any defect in material and workmanship.

If this **Craftsman Snow Thrower** is used for commercial or rental purposes, this warranty applies for only 90 days from the date of purchase.

This warranty does not cover: Expendable items which become worn during normal use, such as spark plugs, tire chains and shear pins.

Repairs necessary because of operator abuse or negligence, including bent crank-shafts and the failure to maintain the equipment according to the instructions contained in the owner's manual.

WARRANTY SERVICE IS AVAILABLE BY CONTACTING THE NEAREST SERVICE CENTER/DEPARTMENT IN THE UNITED STATES. This warranty applies only while this product is in use in the United States.

This warranty gives you specific legal rights, and you may also have other rights which vary from state to state.

SEARS, ROEBUCK AND CO.

DEPT. 698/731A

SEARS TOWER

CHICAGO, IL 60684

OWNER'S INFORMATION

Record the following information about your unit so that you will be able to provide it in case of loss or theft.

DATE PURCHASED: _____ MODEL NO./CODE: 247.886700/ _____

STORE WHERE PURCHASED: ADDRESS _____

CITY: _____ STATE: _____ TELEPHONE: _____

MAINTENANCE AGREEMENT

A SEARS MAINTENANCE AGREEMENT IS AVAILABLE FOR THIS PRODUCT. CONTACT YOUR NEAREST SEARS STORE FOR DETAILS.

TABLE OF CONTENTS

	Page		Page
CRAFTSMAN WARRANTY	2	To Stop Engine	9
OWNER'S INFORMATION	2	Operating the Snow Thrower	9, 10
MAINTENANCE AGREEMENT	2	MAINTENANCE	10, 11
SAFE OPERATION PRACTICES	3	Maintenance Check List	10
ASSEMBLY INSTRUCTIONS	4-6	Lubrication	11
Tools Required for Assembly	4	STORAGE	12
Contents of Shipping Carton	4	ADJUSTMENT/REPAIRS	12-16
Unpacking	4	Skid Shoe Adjustment	12, 13
Installing the Chute Crank	4, 5	Speed Select Lever Adjustment	13
Checking Adjustment of Clutch Cables	5	Cable Adjustment	13
Installing the Headlight Assembly	6	Belt Replacement	13-15
Tire Pressure	6	Auger Shear Bolt Replacement	15
Final Adjustments	6	Spark Plug	15
OPERATING INSTRUCTIONS	6-10	Carburetor Adjustment	16
Engine Operating Controls	6, 7	TROUBLE SHOOTING GUIDE	17
Snow Thrower Operating Controls	7, 8	SNOW THROWER REPAIR PARTS	18-25
To Service Engine	8	ENGINE REPAIR PARTS	26-30
To Start Engine	8, 9	HOW TO ORDER REPAIR PARTS	Back Cover

IMPORTANT

SAFE OPERATION PRACTICES FOR WALK-BEHIND SNOW THROWERS

THIS SYMBOL POINTS OUT IMPORTANT SAFETY INSTRUCTIONS WHICH, IF NOT FOLLOWED COULD ENDANGER THE PERSONAL SAFETY AND/OR PROPERTY OF YOURSELF AND OTHERS. READ AND FOLLOW ALL INSTRUCTIONS IN THIS MANUAL BEFORE ATTEMPTING TO OPERATE YOUR SNOW THROWER.

To reduce the potential for any injury, comply with the following safety instructions. Failure to comply with the instructions may result in personal injury.

TRAINING

1. Read this owner's guide carefully. Be thoroughly familiar with the controls and proper use of the equipment. Know how to stop the unit and disengage the controls quickly.
2. Never allow children to operate equipment. Never allow adults to operate equipment without proper instructions.
3. No one should operate this unit while intoxicated or while taking medication that impairs the senses or reactions.
4. Keep the area of operation clear of all persons, especially small children and pets.
5. Exercise caution to avoid slipping or falling, especially when operating in reverse.
5. Stop engine whenever you leave the operating position, before unclogging the auger/impeller housing or discharge guide, and making any repairs, adjustments, or inspections.
6. Take all possible precautions when leaving the unit unattended. Disengage the auger/impeller, shift into neutral, stop the engine, and remove the key.
7. When cleaning, repairing, or inspecting, make certain auger/impeller and all moving parts have stopped. Disconnect spark plug wire and keep away from plug to prevent accidental starting.
8. Do not run engine indoors, except when starting engine and transporting snow thrower in or out of building. Open doors. Exhaust fumes are dangerous.

PREPARATION

1. Thoroughly inspect the area where the equipment is to be used and remove all door mats, sleds, boards, wires and other foreign objects.
2. Disengage all clutches and shift into neutral before starting engine.
3. Do not operate equipment without wearing adequate winter outer garments. Wear footwear which will improve footing on slippery surfaces.
4. Check the fuel before starting the engine. Gasoline is an extremely flammable fuel. Do not fill the gasoline tank indoors, while the engine is running, or while the engine is still hot. Replace gasoline cap securely and wipe off any spilled gasoline before starting the engine as it may cause a fire or explosion.
5. Use a grounded three wire plug-in for all units with electric drive motors or electric starting motors.
6. Adjust auger housing height to clear gravel or crushed rock surface.
7. Never attempt to make any adjustments while engine is running (except where specifically recommended by manufacturer).
8. Let engine and machine adjust to outdoor temperature before starting to clear snow.
9. Always wear safety glasses or eye shields during operation or while performing an adjustment or repair, to protect eyes from foreign objects that may be thrown from the machine in any direction.
9. Do not clear snow across the face of slopes. Exercise extreme caution when changing direction on slopes. Do not attempt to clear steep slopes.
10. Never operate snow thrower without guards, plates, or other safety protection devices in place.
11. Never operate snow thrower near glass enclosures, automobiles, windows wells, drop offs, etc., without proper adjustment of snow thrower discharge angle. Keep children and pets away.
12. Do not overload machine capacity by attempting to clear snow at too fast a rate.
13. Never operate the machine at high transport speeds on slippery surfaces. Look behind and use care when backing.
14. Never direct discharge at bystanders or allow anyone in front of unit.
15. Disengage power to auger/impeller when transporting or not in use.
16. Use only attachments and accessories approved by the manufacturer of snow thrower (such as wheel weights, counterweights, cabs, etc.).
17. Never operate the snow thrower without good visibility or light. Always be sure of your footing and keep a firm hold on the handles. Walk, never run.

OPERATION

1. Do not put hands or feet near rotating parts. Keep clear of discharge opening at all times.
2. Exercise extreme caution when operating on or crossing gravel drives, walks, or roads. Stay alert for hidden hazards or traffic. Do not carry passengers.
3. After striking a foreign object, stop the engine, remove wire from spark plug, and thoroughly inspect the snow thrower for any damage. Repair the damage before restarting and operating the snow thrower.
4. If the snow thrower should start to vibrate abnormally, stop the engine and check immediately for the cause. Vibration is generally a warning of trouble.

MAINTENANCE AND STORAGE

1. Check shear bolts, engine mounting bolts, etc., at frequent intervals for proper tightness to be sure equipment is in safe working condition.
2. Never store the machine with fuel in the fuel tank inside a building where ignition sources are present, such as hot water and space heaters, clothes dryers, and the like. Allow engine to cool before storing in any enclosure.
3. Always refer to owner's manual instructions for important details if snow thrower is to be stored for an extended period.
4. Maintain or replace safety and instruction labels, as necessary.
5. Run machine a few minutes after throwing snow to prevent freeze up of auger/impeller.

ASSEMBLY INSTRUCTIONS

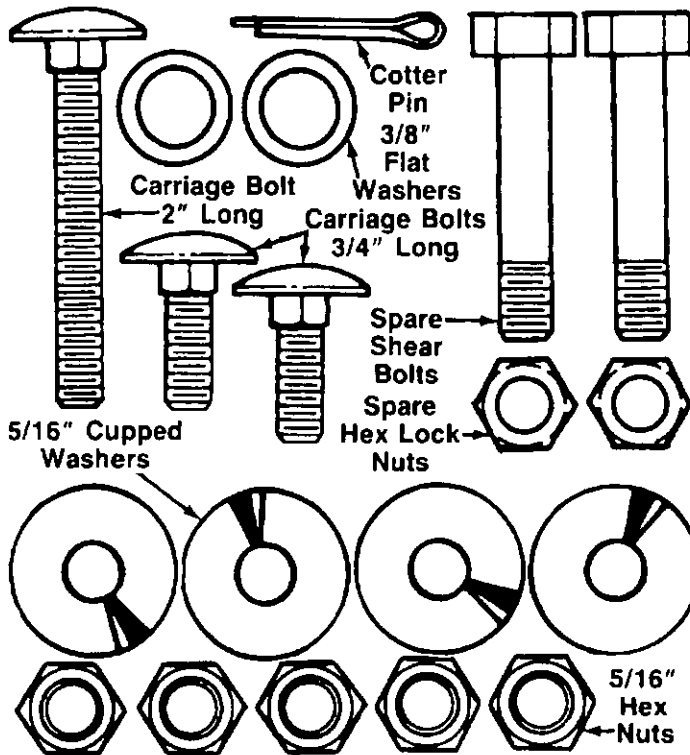

FIGURE 1.

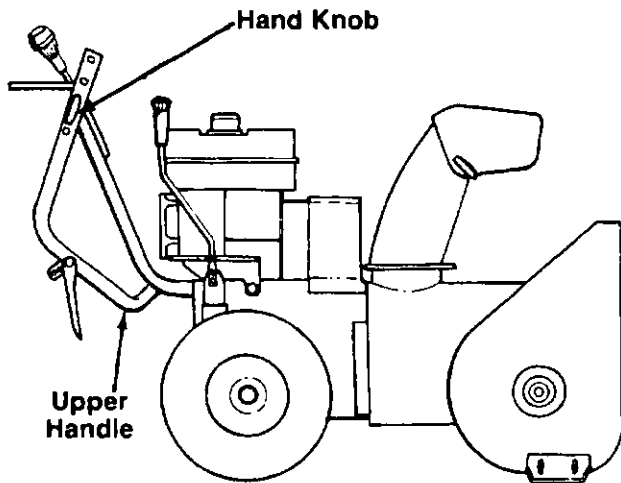

FIGURE 2.

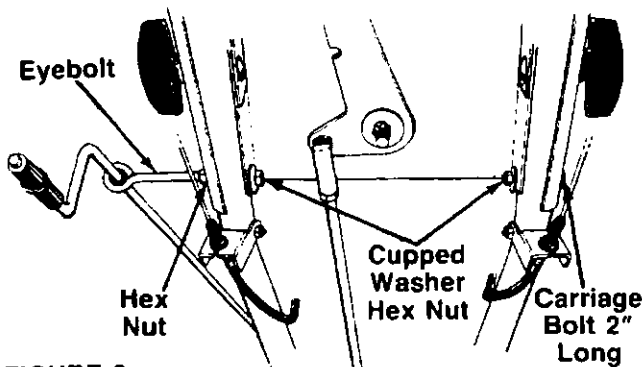

FIGURE 3.

TOOLS REQUIRED FOR ASSEMBLY

- 1 Knife (to cut carton)
- 2 1/2" Wrenches (or Adjustable Wrenches)
- 1 Pair of Pliers
- 1 9/16" Wrench (or Adjustable Wrench)

CONTENTS OF SHIPPING CARTON

1. **Snow Thrower**—completely assembled except for the chute crank assembly, headlight, and upper handle which has been folded down for shipping.
2. **Chute Crank Assembly**
3. **Headlight Kit** (small box) which contains:
 - 1 Headlight Assembly
 - 1 Lock Washer 5/16" I.D.
 - 1 Hex Nut 5/16-18 Thread
 - 2 Cable Ties
4. **Hardware Pack** (plastic bag) which contains the hardware shown in figure 1 (shown actual size), plus one chute crank bracket which is not shown.

UNPACKING

1. Cut the four corners of the carton from top to bottom. Lay the panels flat on the ground.
2. Remove all packing inserts. Make certain all loose parts and literature have been removed before discarding the inserts or carton.
3. The control cables may be taped to the handles for shipping purposes only. Remove any tape that is present.
4. Loosen the hand knobs on each side of the unit. See figure 2. Raise the upper handle into operating position. Do not tighten the hand knobs at this time.
5. Pull the snow thrower out of the carton by the handle.

INSTALLING THE CHUTE CRANK



Reference to right and left hand side of the snow thrower is from the operator's position at the handle.

1. Secure the right hand side of upper and lower handles and handle panel with 2" long carriage bolt, 5/16" cupped washer and hex nut. See figure 3. Install the carriage bolt into the lower hole with the head of the carriage bolt to the outside. Cupped side of washer goes against the handle panel. Tighten securely.
2. Thread one 5/16" hex nut about halfway into the eyebolt on the chute crank assembly.
3. Insert the eyebolt into the lower hole in the left hand side of upper and lower handles and handle panel. Secure with 5/16" cupped washer (cupped side of washer goes against the handle panel) and hex nut. Do not tighten at this time.

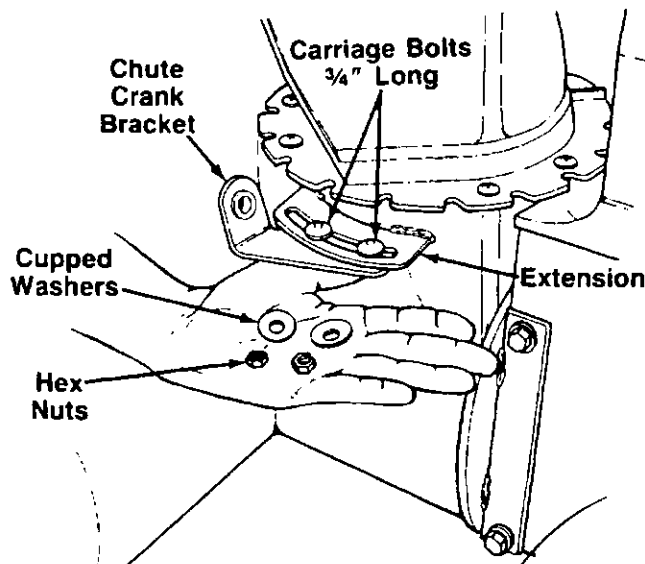

FIGURE 4.

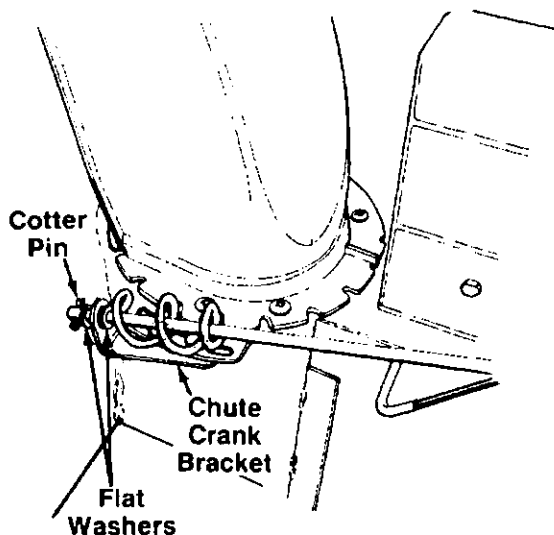

FIGURE 5.

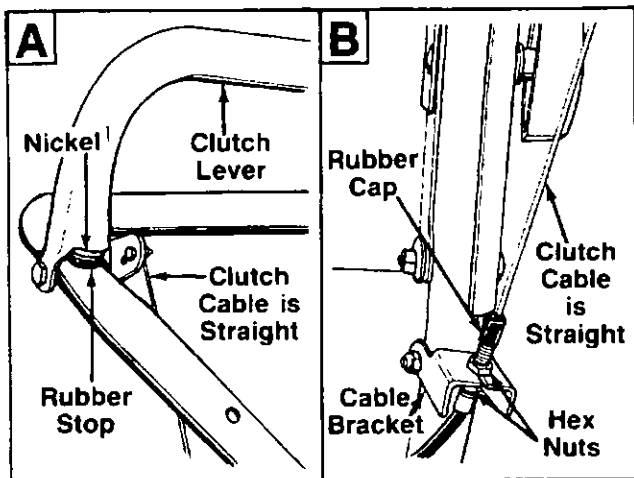

FIGURE 6.

4. Rotate the discharge chute so the opening is facing the front of the snow thrower.
5. Attach chute crank bracket to the extension on the left side of the chute opening (bracket goes beneath the extension) as shown in figure 4. Secure with two $\frac{3}{4}$ " long carriage bolts, $\frac{5}{16}$ " cupped washers (cupped side of washers go against the chute bracket) and hex nuts. Do not tighten at this time.
6. Place one $\frac{3}{8}$ " flat washer on the end of the chute crank assembly. Insert the end of the crank into the plastic bushing in the chute crank bracket. See figure 5.

NOTE

If necessary, adjust the hex nuts on the eyebolt so the chute crank does not touch the engine.

7. Place the other $\frac{3}{8}$ " flat washer on the end of the chute crank, and insert the cotter pin into the hole in the end of crank. Secure by bending the ends of the cotter pin in opposite directions.
8. Adjust the chute crank bracket so the spirals on the chute crank fully engage the notches on the chute. Tighten the hex nuts to secure the bracket in this position.
9. Tighten the hex nuts on the eyebolt at the handle panel.
10. Tighten the hand knobs which secure the upper and lower handles.

CHECK ADJUSTMENT OF CLUTCH CABLES

The clutch cables have been adjusted at the factory. However, check the adjustment before operating the snow thrower. Working on one side of the unit, proceed as follows.

Place a nickel on top of the rubber stop on the upper handle. See figure 6A. Raise the clutch lever so it is just touching the nickel.

The clutch cable should be straight **without putting any pressure on the rubber stop** beneath the nickel.

See figure 6B. **There should be no tension on the cable.**

If adjustment is necessary, adjust the hex nuts at the cable bracket as instructed in the Adjustment section on page 13.

Check the adjustment for the other clutch cable in the same manner.



There must not be any tension on either of the cables with the clutch levers in the released position. Make certain the rubber cap is in place over the threaded end of the cable casing. This rubber cap prevents water from seeping into the casing, which could freeze and cause the controls not to operate correctly.

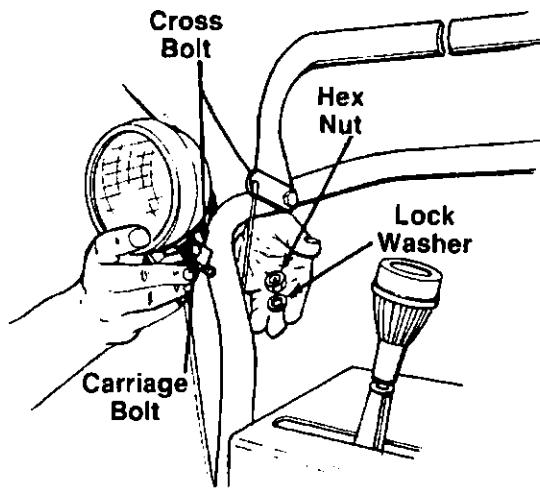

FIGURE 7.

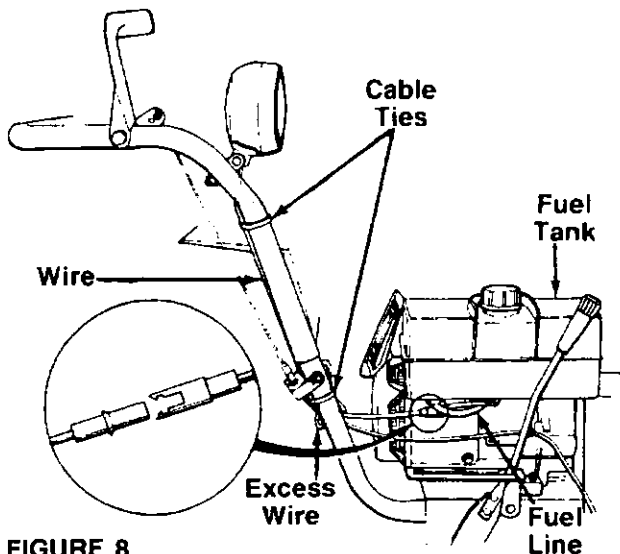

FIGURE 8.

INSTALLING THE HEADLIGHT ASSEMBLY

1. Insert the carriage bolt on the bottom of the headlight assembly through the hole provided on the right hand side of upper handle. See figure 7.
2. Secure with 5/16" lock washer and hex nut provided in the headlight kit.
3. Pivot the headlight so it will illuminate the path to be cleared. Tighten the cross bolt to hold the headlight in this position. See figure 7.
4. Route the wire behind the handle panel and to the inside of the handle as shown in figure 8. Route it to the inside of the fuel line. Plug the wire from the headlight into the wire lead on the engine (located beneath the fuel tank).

5. Secure the wire to the upper handle using one cable tie as shown in figure 8. Loop any excess wire and attach it to the lower handle with the other cable tie as shown.

TIRE PRESSURE

The tires are overinflated for shipping purposes. Check the tire pressure, and reduce to 15 to 20 psi. The tire pressure must be equal in both tires.

FINAL ADJUSTMENTS

Before operating the snow thrower, adjust the skid shoes to accommodate the type of surface to be cleared, and check the adjustment of the speed select lever. Refer to Skid Shoe Adjustment and Speed Select Lever Adjustment in Adjustments/Repairs section on page 12.

OPERATING INSTRUCTIONS

⚠ DANGER

1. STOP ENGINE BEFORE REMOVING DEBRIS AND SERVICING UNIT
2. KEEP CLEAR OF IMPELLER WHILE ENGINE IS RUNNING
3. NEVER DIRECT DISCHARGE AT BYSTANDERS OR WINDOWS OR ALLOW ANYONE IN FRONT OF UNIT
4. THOROUGHLY INSPECT THE AREA WHERE THE EQUIPMENT IS TO BE USED AND REMOVE ALL DOOR MATS, SLEDS, BOARDS, WIRES AND OTHER FOREIGN OBJECTS
5. REFER TO OWNERS MANUAL FOR FULL INSTRUCTIONS

ENGINE OPERATING CONTROLS

The engine operating controls and their functions are as follows (see figure 9):

Throttle Control Lever—Used to control speed of engine.

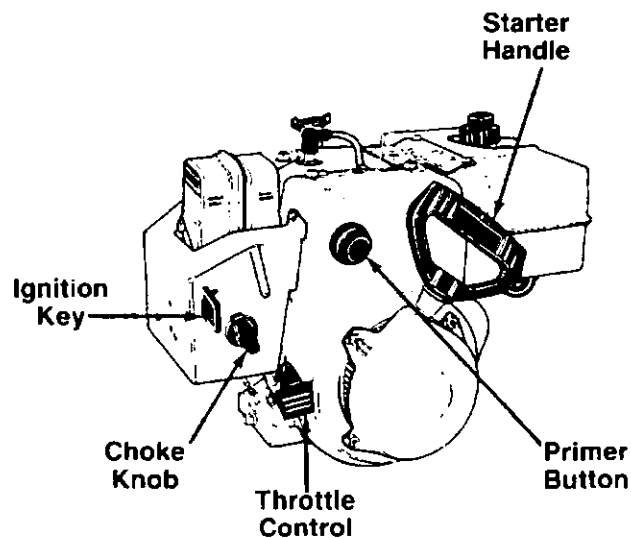

FIGURE 9.

Choke Knob—Use FULL choke position to start a cold engine.

Primer Button—Used to inject fuel directly into the carburetor to insure fast starts in cold weather.

Ignition Key—Must be inserted into ignition key slot to start engine. Pull out to stop. Do not turn ignition key.

Starter Handle—Used to manually start the engine. An Electric Starter kit is available. See Engine Repair Parts section of this manual for kit number.

SNOW THROWER OPERATING CONTROLS

The snow thrower operating controls and their functions are as follows (see figure 10):

Speed Select Lever—Located on the handle panel. The speed select lever allows the operator to use one of the six (6) forward speeds, neutral or reverse. To shift, move the speed select lever to desired position.

➔ NOTE

Release the traction drive clutch lever before shifting gears.

Traction Drive Clutch Lever—Located on the right handle, the traction drive clutch lever is used to propel the snow thrower forward or in reverse. Push lever down to engage; release lever to disengage.

Auger Drive Clutch Lever—Located on the left handle, the auger drive clutch lever is used to engage and disengage the auger and impeller. Push down to engage; release to disengage.

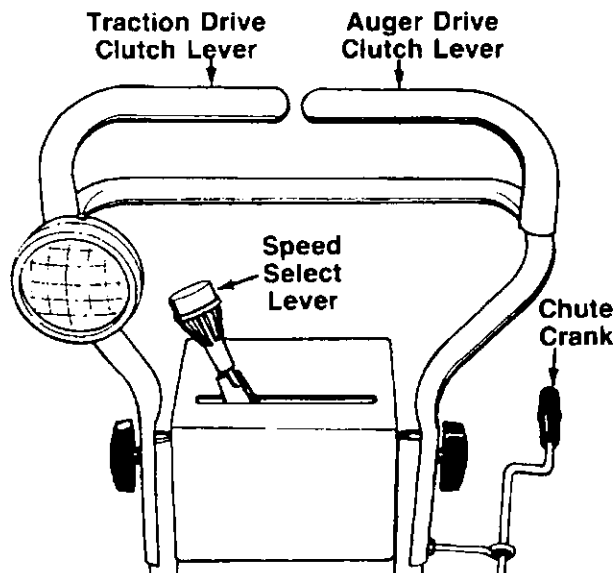

FIGURE 10.

Discharge Chute—The direction snow is thrown can be changed by turning the chute crank. See figure 10. Turn clockwise to discharge to the left. Turn counterclockwise to discharge to the right. The distance snow is thrown can be adjusted by raising the discharge chute for greater distance, or lowering for less distance.

See figure 11. Loosen the hand knob on the side of the discharge chute to adjust. Pivot the chute to desired position, and retighten hand knob.

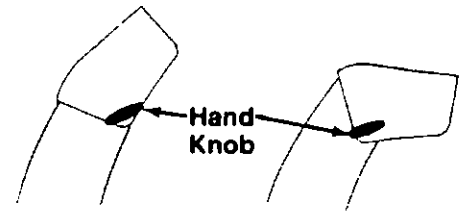

FIGURE 11.

Weight Transfer Lever—Located on the right side of the snow thrower. Move the lever away from the engine, then forward or backward to select one of three positions for operation. See figure 12.

1. Packed Snow—Shifts additional weight to the snow thrower housing to keep the front end down to the ground for hard-packed or icy snow conditions.
2. Normal Snow—Weight is distributed more evenly for normal snow removal.
3. Light Snow—Weight is shifted toward the back of the snow thrower. Use this position when clearing a light snowfall, especially on gravel or uneven surfaces. This is also the best position for transport.

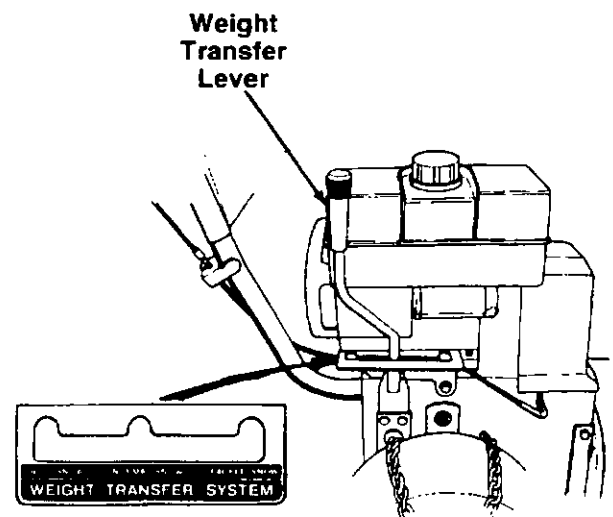

FIGURE 12.

Drive Wheels—The wheels may be adjusted for two different methods of operation. The adjustment is made by moving the "kwik" pin on the ends of the axle to one of two different positions.

1. Dual Wheel Drive—For heavy snow, insert the kwik pins into the wheel hubs for power drive to both wheels. See figure 13.

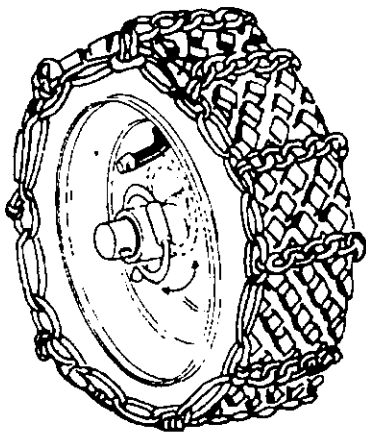

FIGURE 13.

2. Single Wheel Drive—Remove the kwik pin from the wheel hub on one side of the unit, and place in the outside hole in the axle. See figure 14. This position allows power drive to one wheel only, making the unit easier to maneuver during transport. If traction while throwing snow becomes a problem, place kwik pin in Dual Wheel Drive position.

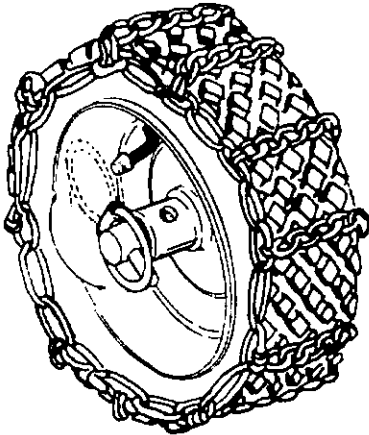
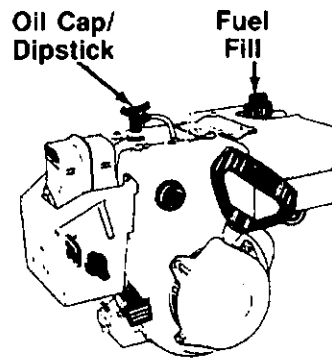

FIGURE 14.

TO SERVICE ENGINE

The engine on this snow thrower was shipped **without** oil in the crankcase. **Oil must be added before engine is started.**

1. Position snow thrower so engine is level. Remove oil fill cap and dipstick. See figure 15. Fill crankcase to FULL mark on dipstick (about 1-1/2 pints) with SAE 10W30 motor oil or equivalent. **Do not overfill.** Tighten fill cap and dipstick securely each time you check oil level. If temperature is consistently 20°F. or lower, SAE 5W30 motor oil may be substituted.
2. Fill fuel tank with clean, fresh, lead-free grade automotive gasoline.



NOTE: Oil level must be between full and add mark

FIGURE 15.

Caution: Experience indicates that alcohol blended fuels (called gasohol or using ethanol or methanol) can attract moisture which leads to separation and formation of acids during storage. Acidic gas can damage the fuel system of an engine while in storage. To avoid engine problems, the fuel system should be emptied before storage for 30 days or longer. Drain the gas tank, start the engine and let it run until the fuel lines and carburetor are empty. Use fresh fuel next season. See Storage section of this manual for additional information.

Never use engine or carburetor cleaner products in the fuel tank or permanent damage may occur.



Never fill fuel tank indoors, when engine is running or while engine is still hot. Never fill fuel tank completely. Fill tank to within 1/4 to 1/2 inch from the top to provide space for expansion of fuel. Wipe up any spilled fuel before starting engine. Store gasoline in a clean, approved container.

3. Make certain the spark plug is tightened securely into engine, and spark plug wire is attached to spark plug. If torque wrench is available, torque plug to between 18 and 23 foot pounds.

TO START ENGINE

1. Make certain the auger and traction drive clutch levers are in the **disengaged** (released) position.
2. Move throttle control up to FAST position. Insert ignition key into slot. See figure 16. Be certain it snaps into place. **Do not turn key.**
3. Rotate choke knob to FULL choke position (cold engine start).

If engine is warm, place choke in OFF position instead of FULL.

4. Push primer button two or three times. See figure 16. If engine is warm, push primer button once only.

NOTE

Always cover vent hole in primer button with finger while pushing. Additional priming may be necessary for the first start if temperature is below 15°F.

5. Grasp starter handle (see figure 16) and pull rope out slowly, until it pulls slightly harder. Let rope re-wind slowly.

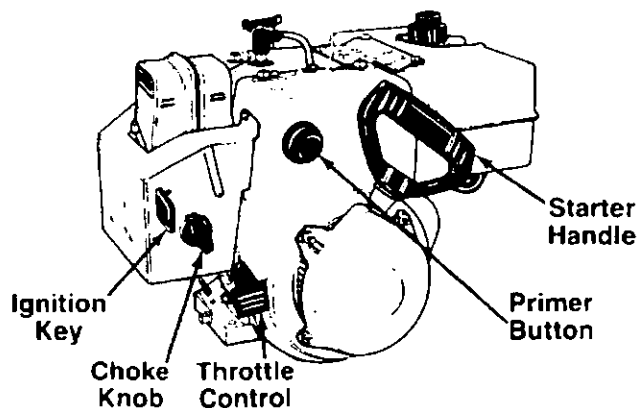

FIGURE 16.

6. Pull starter handle rapidly. Do not allow handle to snap back. Allow it to rewind slowly while keeping a firm hold on the starter handle.

NOTE

If recoil starter is frozen and will not crank the engine, proceed as follows:

- a. Pull as much rope out of the starter as possible.
- b. Release starter handle and let it snap back against the starter.

Only use the above procedure when necessary to free a frozen starter.

7. Repeat steps 5 and 6 until engine starts. If engine fails to start, repeat steps 4, 5 and 6 until engine starts.
8. As engine warms up and begins to operate evenly, rotate choke knob slowly to OFF position. If engine falters, return to FULL choke, then slowly move to OFF position.

NOTE

Allow the engine to warm up for a few minutes as the engine will not develop full power until it reaches operating temperature.



WARNING

Temperature of muffler and surrounding areas may exceed 150°F. Avoid these areas.

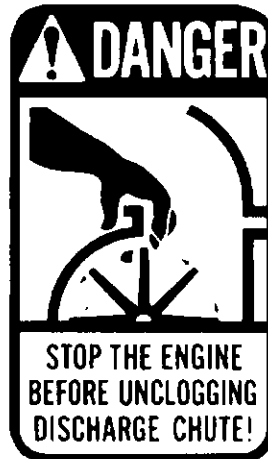

TO STOP ENGINE

1. Run engine for a few minutes before stopping to help dry off any moisture on the engine.
2. To help prevent possible freeze-up of starter, proceed as follows. With engine running, pull starter rope with a rapid, continuous full arm stroke three or four times. Pulling the starter rope will produce a loud clattering sound, which is not harmful to the engine or starter.
3. To stop engine, remove the ignition key. Do not turn key. Disconnect the spark plug wire from the spark plug to prevent accidental starting while equipment is unattended.

NOTE

Do not lose ignition key. Keep it in a safe place. Engine will not start without the ignition key.

4. Wipe all snow and moisture from the carburetor cover in the area of the control levers. Also, move control levers back and forth several times. Move throttle control lever to FAST and leave in this position. Move choke control to FULL choke position.

OPERATING THE SNOW THROWER

1. Start the engine as instructed previously.
2. Adjust the discharge chute up or down as desired. Then use the chute crank to position the discharge to discharge snow with the wind. Do not throw snow toward a building as hidden objects could be discharged with enough force to cause damage.
3. Make certain the weight transfer lever is positioned as necessary for current snow conditions.

- With the traction drive clutch lever released, use the speed select lever to set desired speed. Use a slower ground speed for wet, heavy or deep snow. Reduce speed if the wheels slip. Operate the engine at full throttle for maximum efficiency.



WARNING

Be certain the traction drive clutch lever is released before moving the speed select lever.

- Making certain no bystanders or obstacles are in front of the unit, engage the auger drive clutch lever (located on left handle).
- Engage the traction drive clutch lever, located on the right handle. As the snow thrower starts to move, maintain a firm hold on the handle, and guide the snow thrower along the path to be cleared. Do not attempt the push the snow thrower.

To stop the forward motion, release the traction drive clutch lever. Release the auger drive clutch lever to stop the snow throwing action.

Operating Tips

- For most efficient snow removal, remove snow immediately after it falls.
- Discharge snow downwind whenever possible. Slightly overlap each previous swath.
- Set the skid shoes 1/4" below the scraper bar for normal usage. The skid shoes may be adjusted upward for hard-packed snow. Adjust downward (raising the scraper bar) when using on gravel or uneven surfaces.
- Be certain to follow the precautions listed under "To Stop Engine" on page 9 to prevent possible freeze-up.
- Clean the snow thrower thoroughly after each use.

MAINTENANCE



WARNING

Disconnect the spark plug wire before performing any repairs or maintenance.

MAINTENANCE CHECK LIST

*AFTER FIRST 2 HOURS
BEFORE EACH USE
FREQUENTLY
EVERY 5 HOURS
EVERY 10 HOURS
EVERY 25 HOURS
BEGINNING EACH SEASON
BEFORE STORAGE*

SERVICE RECORD

FILL IN DATES
AS YOU COMPLETE
REGULAR SERVICE

	<i>AFTER FIRST 2 HOURS</i>	<i>BEFORE EACH USE</i>	<i>FREQUENTLY</i>	<i>EVERY 5 HOURS</i>	<i>EVERY 10 HOURS</i>	<i>EVERY 25 HOURS</i>	<i>BEGINNING EACH SEASON</i>	<i>BEFORE STORAGE</i>										
Check Engine Oil		•		•			•											
Change Engine Oil	•					•	•											
Tighten All Bolts and Nuts	•		•															
Check Adjustment of Clutch Cables							•											
Check Spark Plug					•	•												
Adjust Drive Belts	•				•	•												
Lubricate Pivot Points (see below)				•		•	•											
Lubricate Drive Chain				•			•											
Check Fuel		•																
Drain Fuel							•											

The Maintenance Check List is supplied to assist the operator in proper maintenance of the snow thrower. This is only a check list; instructions for adjustments will be found in the Adjustments/Repairs section of this manual.

Some adjustments will need to be made periodically to properly maintain your snow thrower.

All adjustments in Adjustments/Repairs section of this manual should be checked at least once a season. The following should be performed more than once each season.

All Bolts and Nuts—Should be checked often to make certain they are tight, preferably after each use.

Engine and Snow Thrower—Lubricate as instructed in the following section.

LUBRICATION

Engine Lubrication—Check Oil Level before starting engine and every 5 hours of operation. Oil level must be maintained between the "Full" and "Add" marks on dipstick. Refer to "To Service Engine" instructions on page 8.

Change Oil after first 2 hours of operation and every 25 hours thereafter. Change at least once a year if the snow thrower is not used for 25 hours.

To drain oil, position snow thrower so the oil drain plug is the lowest point on the engine. Remove oil drain plug and oil fill cap. See figure 17. Drain oil into a suitable container. Oil will drain more freely when warm.

Replace oil drain plug and tighten securely. Refill crankcase with SAE 10W30 motor oil. SAE 5W30 motor oil may be substituted when temperature is consistently 20°F. or lower.

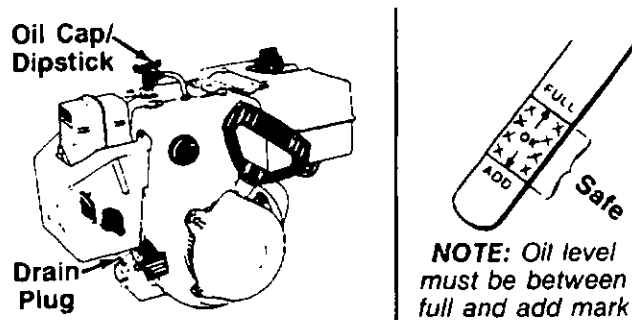

FIGURE 17.

Drive Chain—Using engine oil, lubricate the drive chain after each 10 hours of operation and before storage as follows.

1. Make certain the speed select lever is in Neutral. Tip the snow thrower forward so it rests on the housing.
2. There are two openings in the bottom cover. The drive chain can be oiled through the left opening. Turn the left wheel by hand to rotate the chain so the entire chain can be lubricated.

Pivot Points—Grease pivot slots and pivot arms (both sides of unit) before each season, before storage and after each 10 hours of operation, using a multi-purpose automotive grease. See figure 18. After applying grease, work the weight transfer lever back and forth to distribute the grease.

NOTE

Figure 18 is shown with the wheel removed for clarity only. It is not necessary to remove the wheel to lubricate the pivot slots and pivot arms.

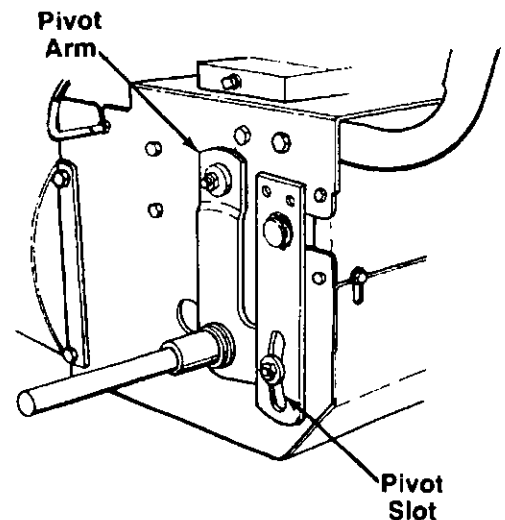

FIGURE 18.

Transmission—The transmission is lubricated at the factory and does not require additional lubrication. If the transmission is disassembled for service, lubricate with 12 ounces of Benalene grease. Order part number 737-0223 (10 ounce tube) through your nearest Sears Service Center.

STORAGE



WARNING

Never store engine with fuel in tank indoors or in poorly ventilated enclosures, where fumes may reach an open flame, spark or pilot light such as on a furnace, water heater, clothes dryer, etc.

It is important to prevent gun deposits from forming in essential fuel system parts such as the carburetor, fuel hose or fuel tank during storage. Also, experience indicates that alcohol blended fuels (called gasohol or using ethanol or methanol) can attract moisture which leads to separation and formation of acids during storage. Acidic gas can damage the fuel system of an engine while in storage.

To avoid engine problems, the fuel system should be emptied before storage of 30 days or longer. Follow these instructions.

1. Run engine until fuel tank is empty and engine stops due to lack of fuel.
2. Disconnect fuel line at carburetor or fuel tank. Be careful not to damage fuel line, fittings or fuel tank. Drain any remaining fuel from the system.



WARNING

Drain fuel into approved container outdoors, away from open flame.



NOTE

If gasohol has been used, complete the preceding instructions. Then put a small amount of unleaded (or regular) grade gasoline into fuel tank and repeat steps 1 and 2.

3. Change oil if it has not been changed recently. Refer to Maintenance section.
4. Remove the spark plug and squirt one ounce of clean engine oil into spark plug hole. Cover the spark plug hole with a clean rag. Pull the starter rope slowly to allow the piston to coat the internal engine parts. Reinstall the spark plug. Do not connect spark plug wire.
5. Thoroughly clean the snow thrower. If unit is to be stored in an unventilated or metal storage shed, coat any metal parts with a light oil or silicone to prevent rust.
6. Store in a clean, dry area.

ADJUSTMENTS/REPAIRS



WARNING

Always stop engine and disconnect spark plug wire before performing any adjustments or repairs.

SKID SHOE ADJUSTMENT

The snow thrower is equipped with two adjustable skid shoes, located on each side of the auger housing. The skid shoes determine the distance between the scraper bar and the ground, which varies according to the type of surface to be cleared.

Normal, Hard Surfaces

When removing snow from a normal, hard surface such as a paved driveway or walk, the skid shoes should be adjusted to be approximately 1/4" lower than the scraper bar.

To adjust, proceed as follows.

1. Place the weight transfer lever in the "Normal Snow" (middle) position.
2. Make certain both tires are inflated equally (15 to 20 psi), and that neither tire is resting on a link of the tire chains.

3. Place the threaded ends of the spare shear bolts (provided in hardware pack) under the scraper bar, one at each end. See figure 19.
4. Loosen the four hex nuts on the skid shoes. Push each skid shoe up or down until it touches the ground. Retighten the hex nuts securely.

Make certain the snow thrower is set at the same height on both sides, and the entire bottom surface of skid shoe is against the ground to avoid uneven wear.

Uneven or Rocky Surfaces

When removing snow from uneven, rocky or gravel surfaces, raise the scraper bar by moving the skid shoes down to avoid throwing gravel. Adjust as instructed above, using thicker objects under the scraper bar to act as spacers.



NOTE

Both the skid shoes and the shave plate are subject to wear and should be replaced when necessary.

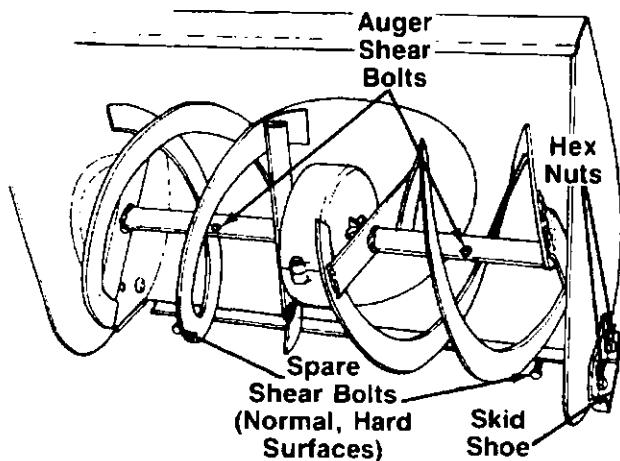

FIGURE 19.
SPEED SELECT LEVER ADJUSTMENT

To check the neutral adjustment for the speed select lever, proceed as follows.

Place the speed select lever in the Neutral position. With the traction drive clutch lever (right hand clutch grip) engaged, roll the unit back and forth. It should move freely.

Move the shift lever to Reverse position. Engage the traction drive clutch lever, and roll the unit back and forth. The wheels should lock up.

If adjustment is needed, loosen the hex nuts near the top and bottom of the speed select rod (bottom nut has left hand threads). See figure 20. Place the unit in neutral (unit will roll freely with the traction drive clutch lever engaged). Check to see that the speed select lever lines up with the "N" on the handle panel. If the indicator on the lever is to the left of the "N", turn the rod clockwise to lengthen the rod as shown in figure 20. If the indicator on the lever is to the right of the "N", turn the rod counterclockwise to shorten the rod. Retighten the hex nuts when the correct adjustment is reached.

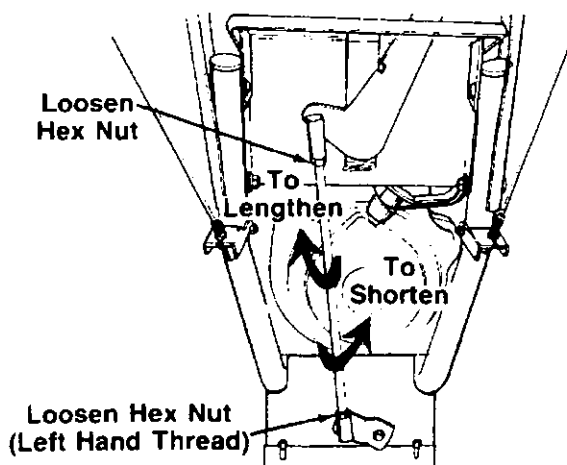

FIGURE 20.
CABLE ADJUSTMENT

Periodic adjustment of the cables may be required due to normal stretch and wear on the belts. Adjustment

is necessary if there is excess slack in either cable with the clutch lever released.

To adjust, loosen the hex nuts at the cable bracket. See figure 21A. Place a nickel on top of the rubber stop on the upper handle. Raise the clutch lever so it is just touching the nickel. See figure 21B. Adjust the hex nuts at the cable bracket so the clutch cable is straight without putting any pressure on the rubber stop on the handle. Move the hex nuts up toward the end of the cable casing to tighten the cable; move the hex nuts down to loosen the cable. When correct adjustment is reached, retighten the hex nuts at the cable bracket. Make certain to slide the rubber cap over the threaded end of the cable casing.



NOTE
There must not be any tension on either cable with the clutch levers in the released position.

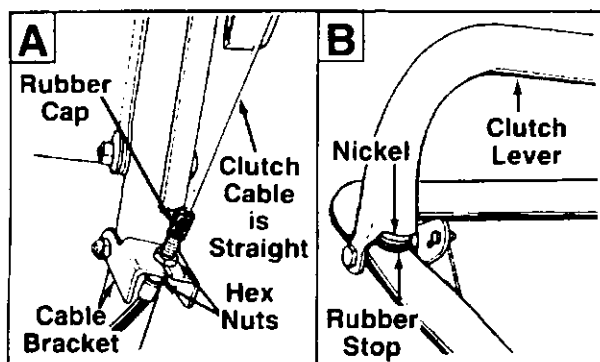

FIGURE 21.
BELT REPLACEMENT
Auger Drive Belt

1. Disconnect the spark plug wire from the spark plug.
2. Disconnect chute crank assembly at the discharge chute by removing the cotter pin and flat washer.
3. Remove the plastic belt cover on the front of the engine by removing three self-tapping screws. See figure 22. A 1/2" wrench is required.

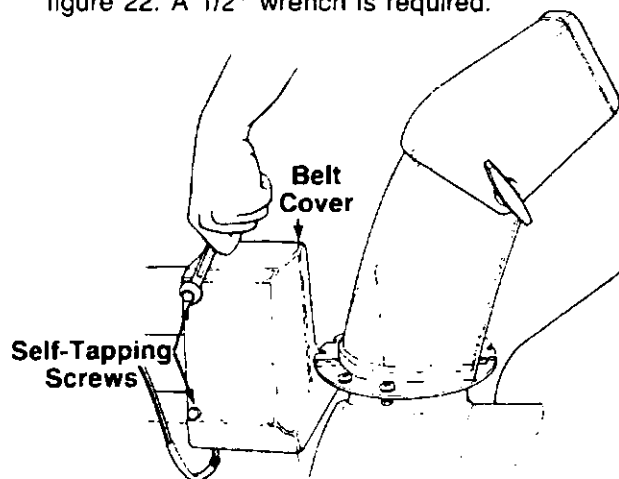

FIGURE 22.

4. Remove the hairpin clip shown in figure 23. Unhook the brake spring from the weld pin on the idler bracket.

NOTE

Figure 23 is shown with the chute assembly removed for clarity only. It is not necessary to remove the chute when replacing the belts.

5. Using a 1/2" wrench, loosen upper left hand belt guard and pivot out of the way. Remove the right hand belt guard and cupped washer. A 9/16" wrench is required.
6. Roll belt off the engine pulley.
7. Unhook the cable from the weld pin on the idler bracket. See figure 23.

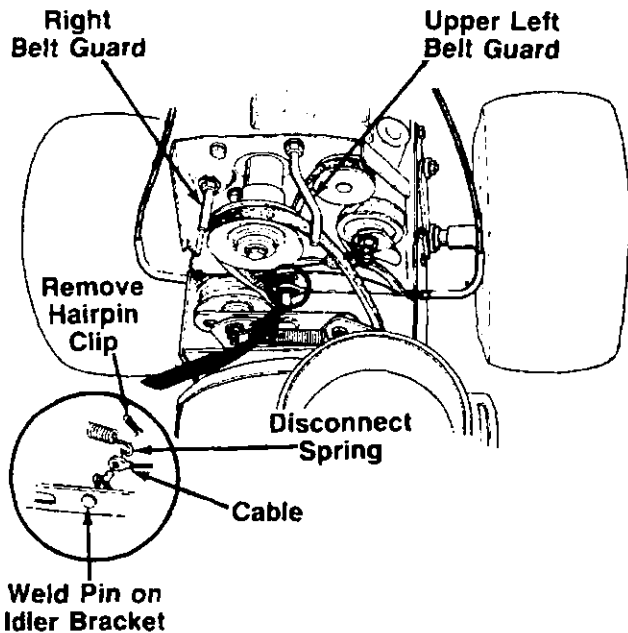

FIGURE 23.

8. Separate the snow thrower into two halves as follows.
 - a. Move weight transfer lever to the "Packed Snow" position.
 - b. Using a 9/16" wrench, remove the top bolts which attach the auger housing to the frame assembly. Loosen (do not remove) the bottom bolts. See figure 24.
 - c. Lift up on the auger drive belt to pull the auger housing off the frame assembly. The snow thrower will separate into two halves.
 - d. Tip the auger housing forward so it rests on the front of the housing.

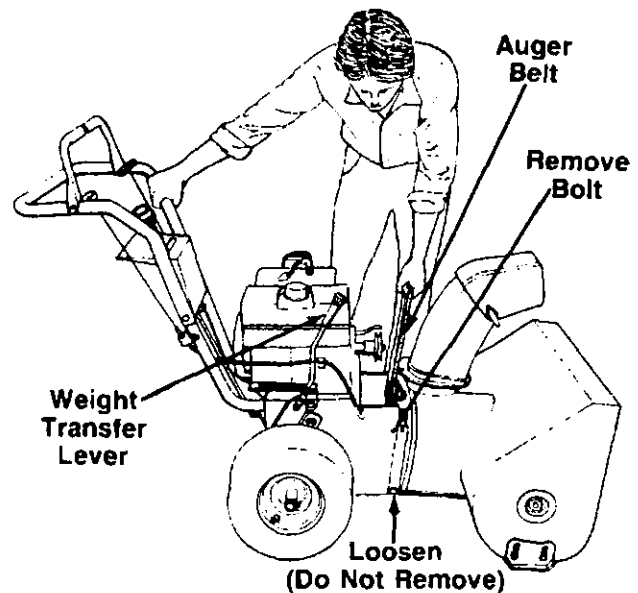

FIGURE 24.

NOTE

Be certain to check the condition of the drive belt when the two halves of the unit are separated. Replace if necessary.

9. Using a 15/16" wrench, remove the four shoulder bolts and cupped washers which act as belt keepers. See figure 25.
10. Roll belt off the auger pulley.
11. Remove the second hairpin clip from the weld pin on the idler bracket.
12. Push the idler to the right to extend the spring. Remove belt from between idler pulley and weld pin. See figure 25.
13. Reassemble new belt in reverse order.

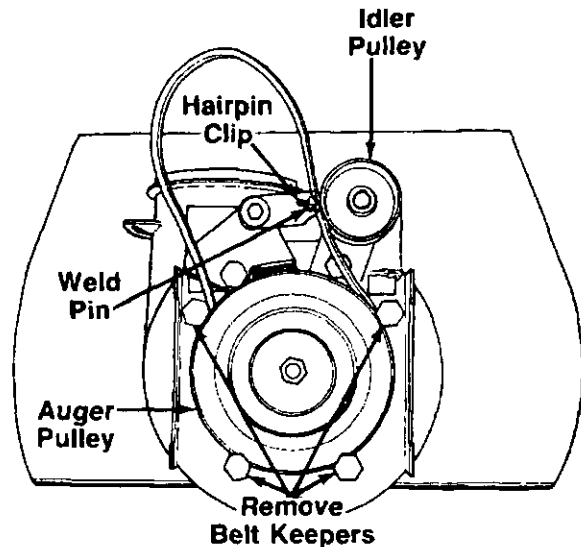

FIGURE 25.

Drive Belt

1. Follow steps 1 through 8 of the previous section.
2. Disconnect the drive cable from the traction drive clutch lever (on right side of handle) by removing the hex nut and slipping the cable off the weld pin.
3. Unhook the spring from the idler bracket. See figure 26.

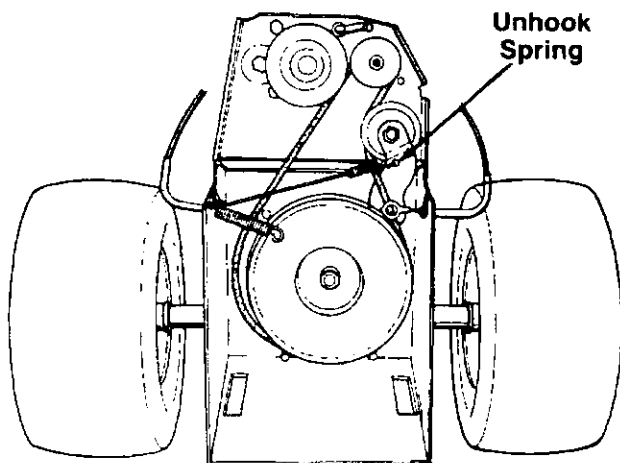

FIGURE 26.

4. Slip belt from between belt guard and fixed idler pulley as shown in figure 27.
5. Using a 1/8" Allen wrench, loosen (do not remove) the two set screws in the groove of the fixed idler pulley.

NOTE

The two set screws are on opposite sides of the pulley. It may be necessary to pull the starter rope slightly to rotate the pulley, which will allow access to the set screws. Be certain spark plug wire is disconnected.

6. Remove the fixed idler pulley and belt. Remove belt from around idler pulley.
7. Using a 3/4" socket wrench, remove the center nut from the drive pulley. Slide pulley out, and remove the belt.
8. Reassemble the new belt, following instructions in reverse order.

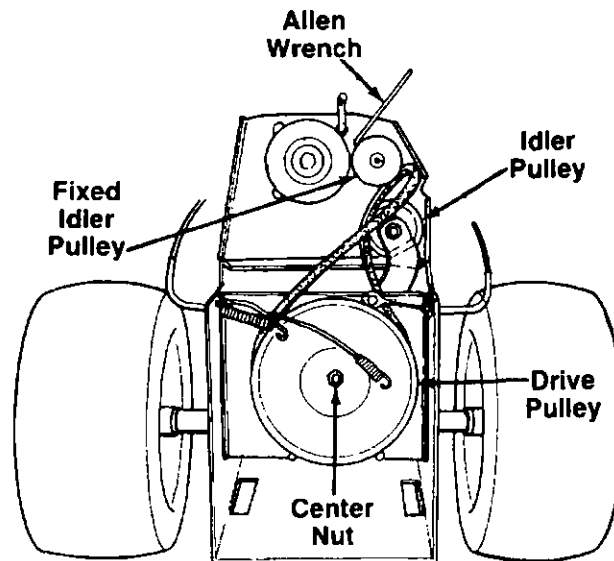

FIGURE 27.

AUGER SHEAR BOLT REPLACEMENT

The augers are secured to the auger shaft with two special shear bolts and hex lock nuts. If you hit a foreign object or ice jam, snow thrower is designed so the bolts will break (to protect the snow thrower). Refer to figure 19.

If the augers will not turn, check to see if the hex bolts have sheared. Two spare bolts and hex lock nuts have been provided with the snow thrower. Use only original equipment shear bolts and nuts, part numbers 710-0890 (shear bolt) and 712-0429 (hex lock nut).

SPARK PLUG

Clean spark plug and reset gap periodically. Clean area around spark plug base before removing to prevent dirt from entering engine. Replace spark plug if electrodes are pitted or burned, or if porcelain is cracked. Spark plug replacement is recommended at beginning of each season. Refer to Engine Repair Parts section of this manual for proper replacement plug. If reusing spark plug, clean by carefully scraping electrodes (do not sand blast or use wire brush). Be certain entire spark plug is clean. Check electrodes gap with a wire feeler gauge, and reset gap to 0.030 if necessary. See figure 28.

Install spark plug in engine, and tighten securely. If torque wrench is available, torque plug to between 18 and 23 foot pounds.

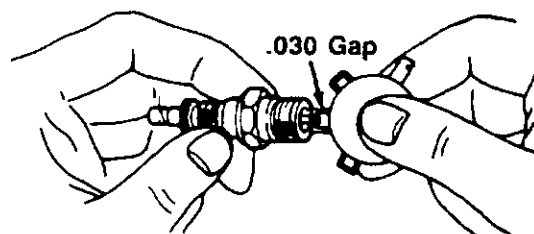

FIGURE 28.

CARBURETOR ADJUSTMENT



WARNING

If any adjustments are made to the engine while the engine is running (e.g., carburetor), keep clear of all moving parts. Be careful of heated surfaces and muffler.

The carburetor has been pre-set at the factory and should not require adjustment. However, if the carburetor needs adjustment, proceed as follows. See figure 29.

1. Close high speed adjusting screw by hand. Do not overtighten. Then open it 1 1/4 to 1 1/2 turns.
2. Close idle adjusting screw by hand. Do not overtighten. Then open it 1 1/4 to 1 1/2 turns.
3. Start the engine, and allow it to warm up.
4. Set the throttle control to FAST. Adjust high speed adjusting screw in or out until the engine runs smoothly at full throttle. If the engine has a tendency to stall under load, open high speed adjusting screw slightly to obtain a richer fuel mixture.
5. Set the throttle control to SLOW. Adjust idle adjusting screw in or out until the engine runs smoothly at idle.

Allow the engine to run undisturbed for a few seconds between each new setting so that the engine can react to each setting.



WARNING

Never tamper with the engine governor, which is set at the factory for proper engine speed. Overspeeding the engine above factory high speed setting is dangerous. If you think the engine governed high speed needs adjusting, contact your nearest SEARS Service Center, who has the proper equipment and experience to make any necessary adjustments.

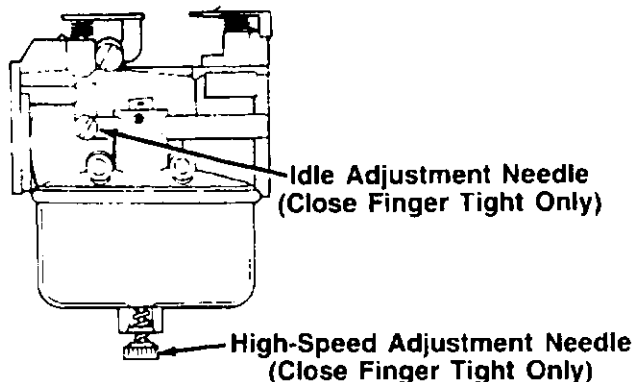

FIGURE 29.

TROUBLE SHOOTING GUIDE

TROUBLE	POSSIBLE CAUSE(S)	CORRECTIVE ACTION
Engine fails to start	<ol style="list-style-type: none"> 1. Fuel tank empty, or stale fuel. 2. Blocked fuel line. 3. Key not in switch on engine. 4. Spark plug wire disconnected. 5. Faulty spark plug. 	<ol style="list-style-type: none"> 1. Fill tank with clean, fresh gasoline. 2. Clean fuel line. 3. Insert key. 4. Connect wire to spark plug. 5. Clean, adjust gap or replace.
Engine runs erratic	<ol style="list-style-type: none"> 1. Unit running on CHOKE. 2. Blocked fuel line or stale fuel. 3. Water or dirt in fuel system. 4. Carburetor out of adjustment. 	<ol style="list-style-type: none"> 1. Turn choke knob to OFF position. 2. Clean fuel line; fill tank with clean fresh gasoline. 3. Remove carburetor bowl to drain fuel tank. Refill with fresh fuel. 4. Adjust carburetor (see Carburetor Adjustment in Adjustments/Repairs section of this manual).
Loss of power	<ol style="list-style-type: none"> 1. Spark plug wire loose. 2. Gas cap vent hole plugged. 	<ol style="list-style-type: none"> 1. Connect and tighten spark plug wire. 2. Remove ice and snow from cap. Be certain vent hole is clear.
Engine overheats	<ol style="list-style-type: none"> 1. Carburetor not adjusted properly. 2. Engine oil level low. 	<ol style="list-style-type: none"> 1. Adjust carburetor (see Carburetor Adjustment in Adjustments/Repairs section of this manual). 2. Fill crankcase with the proper oil.
Excessive vibration	Loose parts or damaged impeller.	Stop engine immediately and disconnect spark plug wire. Tighten all bolts and nuts. Make all necessary repairs. If vibration continues, have unit serviced by a SEARS Service Center.
Hard to shift, or will not shift	Speed select rod misadjusted	Readjust speed select rod (see Speed Select Lever Adjustment in Adjustments/Repairs section of this manual).
Unit fails to propel itself	<ol style="list-style-type: none"> 1. Unit in neutral. 2. Kwik pins not in proper position. 3. Incorrect adjustment of traction drive cable. 4. Drive belt loose or damaged. 5. Transmission problem. 	<ol style="list-style-type: none"> 1. Move speed select lever to one of the 6 forward speeds or reverse (readjust speed select lever if needed). 2. Place kwik pins in wheel hub. 3. Adjust traction drive cable. Refer to Cable Adjustment in Adjustments/Repairs section of this manual. 4. Replace drive belt. Refer to Belt Replacement in Adjustments/Repairs section of this manual. 5. Have unit serviced by a SEARS Service Center.
Unit fails to discharge snow	<ol style="list-style-type: none"> 1. Shear bolt broken. 2. Discharge chute clogged. 3. Foreign object lodged in auger. 4. Incorrect adjustment of auger drive cable. 5. Auger drive belt loose or damaged. 	<ol style="list-style-type: none"> 1. Replace shear bolt. Refer to Auger Shear Bolt Replacement in Adjustments/Repairs section of this manual. 2. Stop engine immediately and disconnect spark plug wire. Clean discharge chute and inside of auger housing. 3. Stop engine immediately and disconnect spark plug wire. Remove object from auger. 4. Adjust auger drive cable. Refer to Cable Adjustment in Adjustments/Repairs section of this manual. 5. Replace auger drive belt. Refer to Belt Replacement in Adjustments/Repairs section of this manual.

NOTE: For repairs beyond the minor adjustments listed above, please contact your nearest SEARS Service Center.

Repair Parts—Handle Details

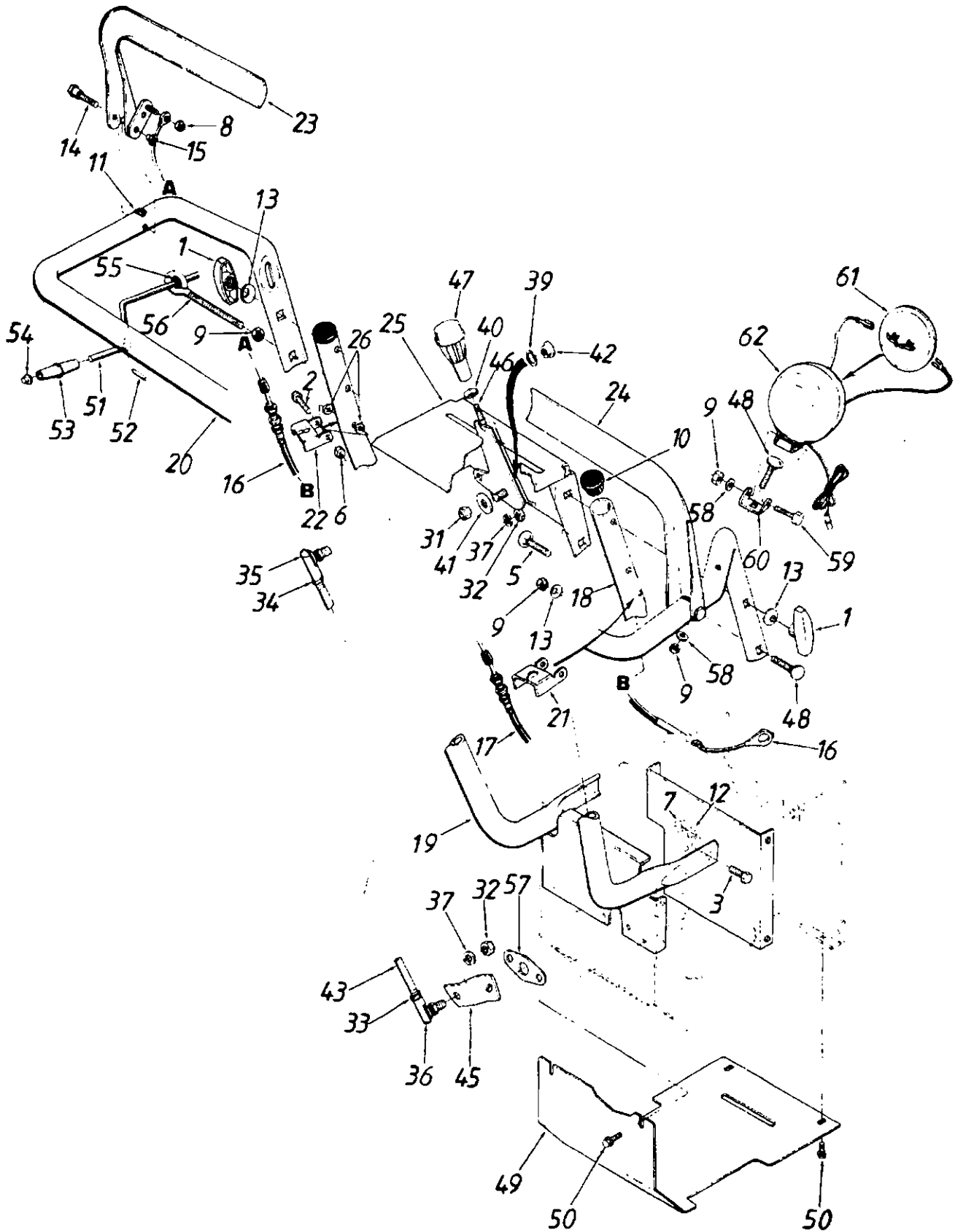

SEARS CRAFTSMAN 26" SNOW THROWER MODEL NO. 247.886700

Repair Parts

KEY NO.	PART NO.	DESCRIPTION	KEY NO.	PART NO.	DESCRIPTION
1	09966	Hand Knob	34	712-0711	Hex Jam Nut 3/8-24 Thd.
2	710-0136	Hex Bolt 1/4-20 x 1.75" Lg.	35	723-0156	Ball Joint Ass'y. 3/8-24 Thd.
3	710-0216	Hex Bolt 3/8-16 x .75" Lg.*	36	723-0351	Ball Joint Ass'y. 3/8-24 L.H. Thd.
5	710-0572	Carriage Bolt 5/16-18 x 2.5" Lg.	37	736-0169	L-Wash. 3/8" I.D.*
6	712-0291	Hex L-Nut 1/4-20 Thd.	39	736-0185	FI-Wash. .406" I.D.
7	712-0798	Hex Nut 3/8-16 Thd.*	40	736-0256	FI-Wash. .635" I.D.
8	712-0392	Hex Lock Stop Nut 1/4-28 Thd.	41	736-0219	Bell-Wash. .39" I.D.
9	712-0267	Hex Nut 5/16-18 Thd.*	42	738-0372	Shoulder Spacer
10	731-0496	Plastic Plug	43	747-0577	Shift Rod
11	735-0199	Rubber Bumper	45	784-5390	Shift Arm
12	736-0169	L-Wash. 3/8" I.D.*	46	784-5392	Shift Lever Ass'y.
13	736-0242	Bell-Wash. .345" I.D.	47	720-0218	Shift Knob
14	738-0560	Shld. Bolt .374" Dia.	48	710-0487	Carriage Bolt 5/16-18 x 2" Lg.
15	738-0561	Shld. Nut 1/4-20 Thd.	49	784-5388	Bottom Cover
16	746-0692	Clutch Cable 25.5" Lg.	50	710-0599	Hex TT-Tap Scr. 1/4-20 x .5" Lg.
17	746-0693	Auger Cable 25.5" Lg.	51	05980	Chute Crank Ass'y.
18	749-0779	Lower Handle—R.H.	52	715-0138	Roll Pin 1/8" Dia.
19	749-0780	Lower Handle—L.H.	53	720-0201A	Chute Crank Knob
20	749-0783	Upper Handle Ass'y.	54	726-0100	Pushnut 3/8" Rod
21	784-5394	Cable Bracket—R.H.	55	741-0475	Plastic Bushing .38" I.D.
22	784-5395	Cable Bracket—L.H.	56	747-0416A	Eyebolt
23	784-5431	Clutch Grip Ass'y.—L.H.	57	784-5386	Shift Support
24	784-5432	Clutch Grip Ass'y.—R.H.	58	736-0119	L-Wash. 5/16" I.D.
25	784-5433	Handle Panel Ass'y.	59	710-0116	Hex Bolt 5/16-18 x 2.0" Lg.*
26	736-0142	FI-Wash. 1/4" I.D. x 1/2" O.D.	60	13359	Lamp Mounting Brkt.
31	712-0181	Hex Ins. L-Nut 3/8-16 Thd.	61	725-1300	Headlight
32	712-0241	Hex Nut 3/8-24 Thd.	62	725-0586	Headlight Housing
33	712-0312	Hex Nut 3/8-24 L.H. Thd.	—	770-6675D	Owner's Manual

*Common Hardware—May be purchased locally.

Repair Parts—Auger/Housing Details

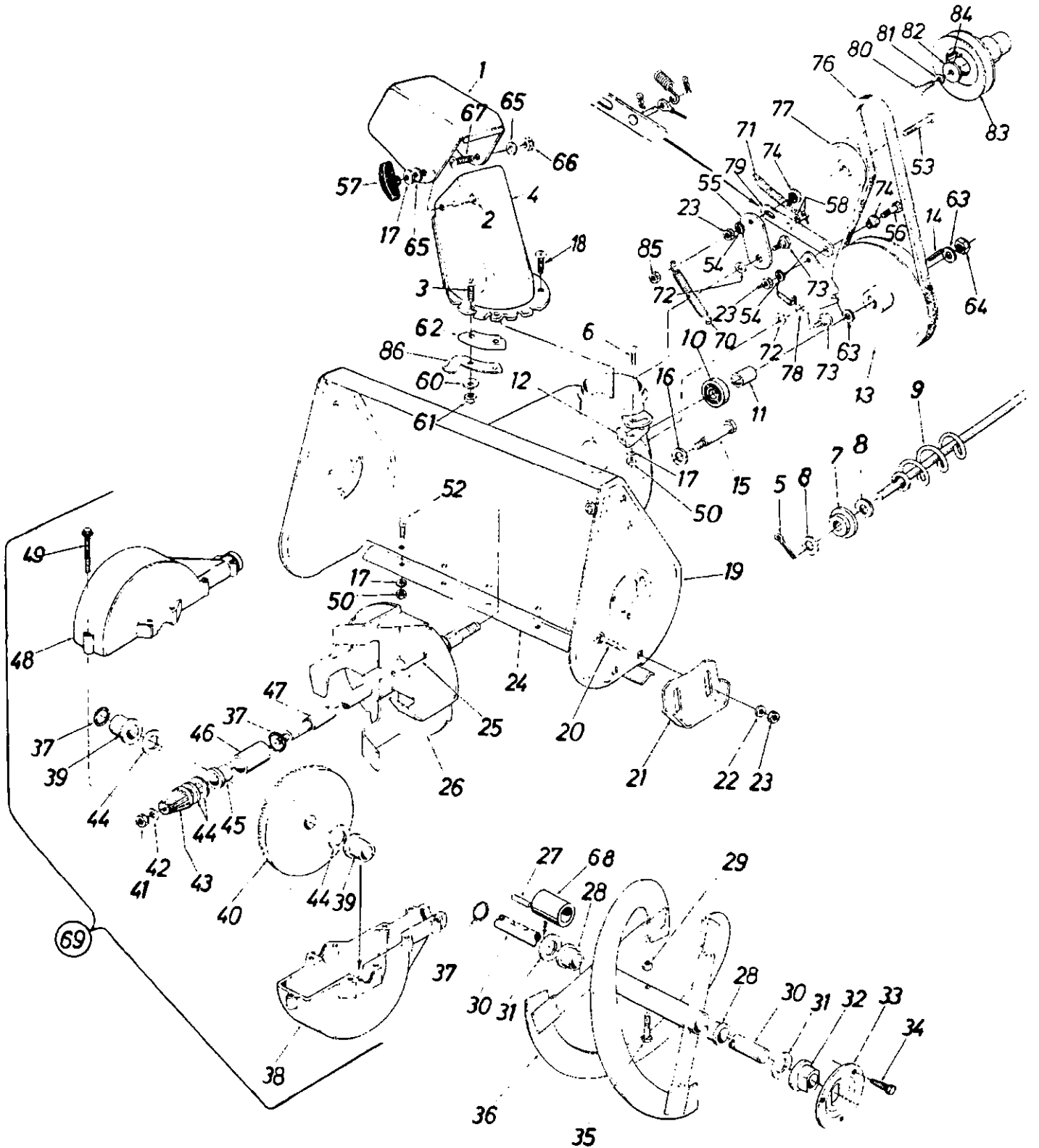

SEARS CRAFTSMAN 26" SNOW THROWER MODEL NO. 247.886700

Repair Parts

KEY NO.	PART NO.	DESCRIPTION	KEY NO.	PART NO.	DESCRIPTION
1	731-0848	Upper Chute	41	712-0237	Hex Cent. L-Nut 5/16-24 Thd.
2	710-0276	Carriage Bolt 5/16-18 x 1.0" *	42	736-0264	Fl-Wash. .34" I.D. x .62"
3	710-0166	Truss Mach. Scr. 1/4-20 x 1" *	43	748-0237	Pinion Gear
4	731-0844	Lower Chute	44	736-0287	Fl-Wash. .75" I.D. x 1.25"
5	714-0507	Cotter Pin	45	748-0171	Flange Brg. .755" I.D.
6	710-0451	Carriage Bolt 5/16-18 x .75" *	46	748-0106	Sleeve Brg. .755" I.D.
7	741-0475	Bushing	47	738-0649	Blower Axle
8	736-0140	Fl-Wash. .385 I.D. x .62" O.D.	48	717-0455	Bevel Gear Housing—Upper Half
9	05980	Chute Crank Ass'y.	49	710-0588	Hex Wash. Hd. Self-Tap Scr. 1/4-20 x 1.00" Lg.
10	741-0155	Ball Brg. .62" I.D. x 1.38"	50	712-0267	Hex Nut 5/16-18 Thd. *
11	750-0118	Spacer .63" I.D. x .88" O.D.	52	710-0260	Carriage Bolt 5/16-18 x .62" Lg. *
12	784-5123	Chute Crank Brkt.	53	710-0427	Hex Bolt 3/8-16 x 2" Lg. *
13	756-0418	5/8" "V"-Pulley .625" I.D. x 7.5" O.D.	54	738-0169	L-Wash. 3/8" I.D. *
14	714-0388	#61 Hi-Pro Key 3/16" x 5/8" Dia.	55	05895	Auger Clutch Idler Brkt.
15	738-0154A	Shld. Bolt .50" Dia. x 2.11"	56	710-0723	Hex Bolt 3/8-16 x 1.25" Lg. *
16	736-0105	Bell-Wash. .40" I.D. x .88"	57	09966	Knob
17	736-0242	Bell-Wash. .34" I.D. x .88"	58	714-0104	Int. Cotter Pin 5/16" Dia.
18	710-0255	Truss Mach. Scr. 1/4-20 x .75" *	60	736-0142	Fl-Wash. 1/4" I.D.
19	784-5398	26" Blower Housing Ass'y.	61	712-0107	Hex L-Nut 1/4-20 Thd. *
20	710-0790	Carriage Bolt 3/8-16 x .62" *	62	731-0851	Chute Flange Keeper
21	05002	Slide Shoe	63	736-0116	Fl-Wash. .64" I.D. x .94"
22	736-0105	Bell-Wash. 3/8" I.D.	64	712-0923	Hex Jam Nut 5/8-18 Thd.
23	712-0342	Hex Jam Nut 3/8-16 Thd.	65	736-0231	Fl-Wash. .344 I.D. x 1.125
24	784-5244	26" Shave Plate	66	712-0158	Hex L-Nut 5/16-18 Thd.
25	715-0114	Spring Pin Spiral 1/4" Dia. x 1.50" Lg.	67	710-0323	Truss Mach. Scr. 5/16-18 x .75" Lg. *
26	05865A	11" Dia. Blower Fan Ass'y.	68	750-0190	Spacer
27	714-0133	Sq. Key 3/16" x 1.5" Lg.	69	717-0836A	Gear Box Complete
28	741-0493	Flange Brg. .75" I.D. x .88"	70	732-0550	Extension Spring 4" Lg.
29	712-0429	Hex Ins. L-Nut 5/16-18	71	732-0599	Extension Spring 3.3" Lg.
30	738-0711A	Spiral Axle	72	736-0219	Bell-Wash. .4" I.D. x 1.13"
31	736-0188	Fl-Wash. .75" I.D. x 1.50"	73	738-0281	Shld. Bolt .625" Dia.
32	741-0300	Flange Brg. w/Flats .755" I.D.	74	738-0347	Shld. Spacer .625" I.D.
33	05845	Bearing Housing	76	754-0357	V-Belt
34	710-0726	Hex Wash. Hd. Self-Tap Scr. 5/16-24 x .62" Lg.	77	756-0225	Fl-Idler 3.12" O.D.
35	710-0890	Shear Bolt 5/16-18 x 1.5" Lg.	78	784-5048	Brake Brkt. Ass'y.
36	05923	26" Spiral Ass'y.—L.H.	79	784-5426	Brake Link Ass'y.
	05924	26" Spiral Ass'y.—R.H. (Not Shown)	80	710-0459	Hex Bolt 3/8-24 x 1.5" Lg.
37	721-0176	"O"-Ring—3/4" I.D.	81	736-0169	L-Wash. 3/8" I.D. *
38	717-0456	Bevel Gear Housing—Lower Half	82	736-0247	Washer .39" I.D. x 1.25"
39	741-0293	Plastic Flange Brg. .755" I.D.	83	756-0533	Engine Pulley
40	717-0457B	Bevel Gear	84	714-0114	Sq. Key 1/4" x 2" Lg.
			85	712-0266	Hex Jam Nut 3/8-16 Thd.
			86	784-0273	Chute Stop

*Common Hardware—May be purchased locally.

Repair Parts—Drive Mechanism Details

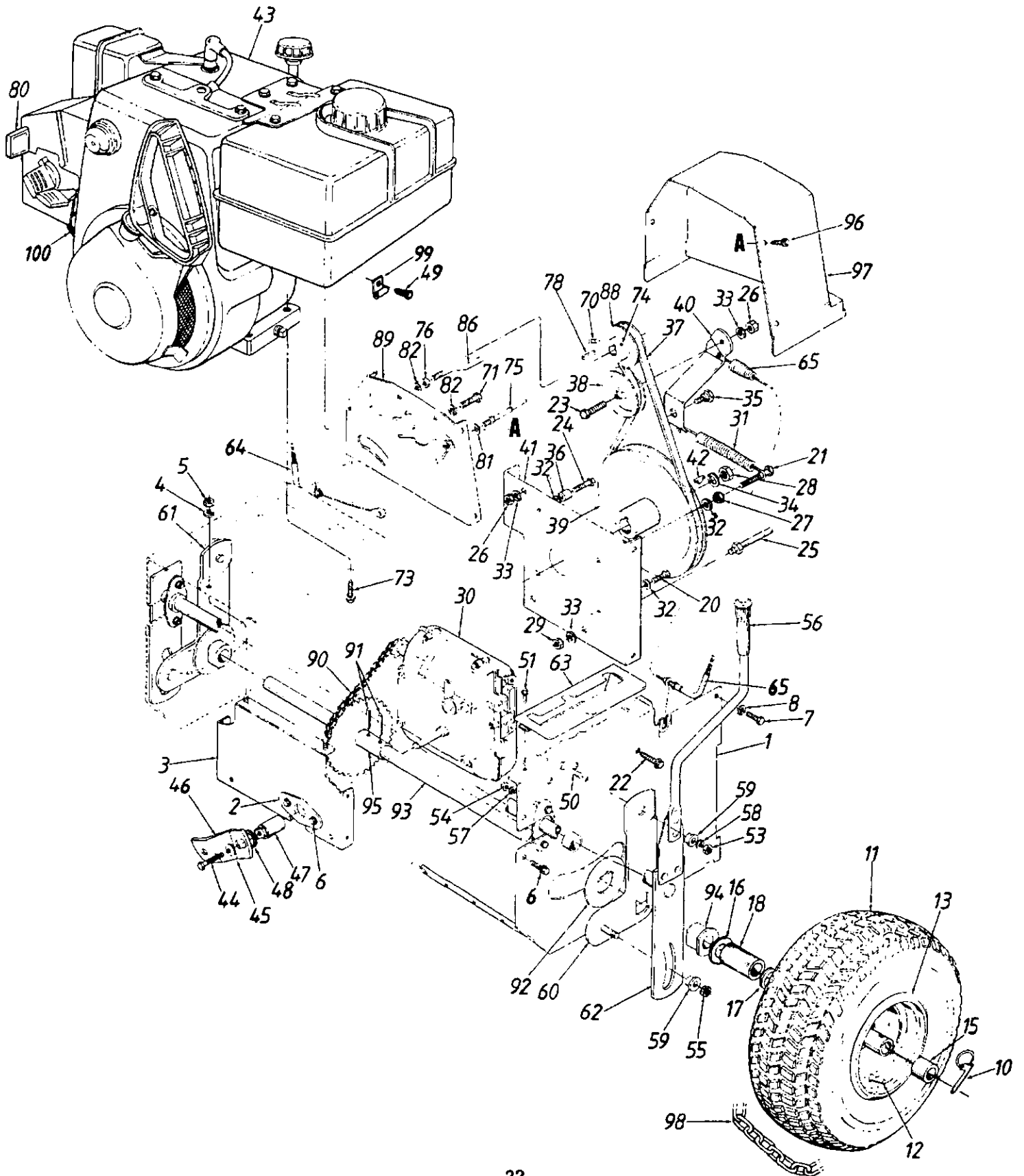

SEARS CRAFTSMAN 26" SNOW THROWER MODEL NO. 247.886700

Repair Parts

KEY NO.	PART NO.	DESCRIPTION	KEY NO.	PART NO.	DESCRIPTION
1	784-5384	Frame Ass'y.	47	748-0327	Shift Arm Extension
2	784-5386	Shift Support	48	736-0256	Fl-Wash. .63" I.D. x .93" O.D.
3	784-5382	Back Plate Ass'y.	49	710-0289	Hex Bolt 1/4-20 x .5" Lg.*
4	736-0329	L-Wash. 1/4" I.D.*	50	710-0152	Hex Bolt 3/8-24 x 1" Lg.*
5	712-0287	Hex Nut 1/4-20 Thd.*	51	710-0603	Hex Wash. Hd. B-Tap Scr. 5/16-18 x .5"
6	710-0599	Hex TT-Tap Scr. 1/4-20 x .5" Lg.	53	712-0241	Hex Nut 3/8-24 Thd.*
7	710-0623	Hex Self-Tap Scr. 3/8-16 x .75" Lg.	54	712-0267	Hex Nut 5/16-18 Thd.*
8	736-0217	L-Wash. 3/8" I.D.	55	712-0116	Hex L-Nut 3/8-24 Thd. Gr. 5
10	714-0143	Kwick Pin	56	720-0223	Grip
11	734-1417	Wheel Ass'y. Comp.	57	736-0119	L-Wash. 5/16" I.D.*
	734-1375	Tire Only	58	736-0169	L-Wash. 3/8" I.D.*
12	734-0255	Air Valve	59	738-0372	Shoulder Spacer
13	734-1145	Rim Only	60	784-5318	Side Arm Ass'y.—R.H.
15	741-0401	Sleeve Brg. .755" I.D.	61	784-5319	Side Arm Ass'y.—L.H.
16	736-0287	Fl-Wash. .793" I.D.	62	784-5321	Pivot Handle Ass'y.
17	736-0315	Fl-Wash. .75" I.D.	63	784-5389	Position Selector Plate
18	750-0442	Spacer .75" I.D.	64	746-0692	Clutch Cable 25.5" Lg.
20	710-0118	Hex Bolt 5/16-18 x .75" Lg.*	65	746-0693	Auger Cable 25.5" Lg.
21	710-0442	Hex Bolt 5/16-18 x 1.5" Lg.*	70	710-0188	Set Scr. 1/4-28 x .18"
22	710-0603**	Hex Wash. Hd. B-Tap Scr. 5/16-18 x .5" Lg.*	71	710-0237	Hex Bolt 5/16-24 x .62"
			73	710-0502A	Hex L-Wash. TT-Tap Scr. 3/8-16
23	710-0459	Hex Bolt 3/8-24 x 1.5" Lg.	74	710-0938	Set Scr. 1/4-28 x .25"
24	710-0874	Hex Bolt 5/16-18 x 1.25" Lg.*	75	711-0769	Stud 3/8-16 x 3.37" Lg.
25	711-0640	Stud 3/8-16 x 2.75" Lg.	76	712-0123	Hex Nut 5/16-24 Thd.*
26	712-0241	Hex Nut 3/8-24 Thd.	78	714-0131	Key 3/32" x 5/8" Dia.
27	712-0267	Hex Nut 5/16-18 Thd.*	80	725-1377	Plastic Key—Craftsman
28	712-0333	Nut 1/2-20 Thd.	81	736-0105	Bell-Wash. .38" I.D. x .88"
29	712-0342	Hex Jam Nut 3/8-16 Thd.	82	736-0119	L-Wash. 5/16" I.D.*
30	717-0944	Transmission Comp.	86	747-0716	Belt Guard Scr.
31	732-0429	Extension Spring 3.97" Lg.	88	756-0538	Auxiliary PTO Pulley
32	736-0119	L-Wash. 5/16" I.D.*	89	784-5396	Engine Plate Ass'y.
33	736-0169	L-Wash. 3/8" I.D.*	90	713-0394	Chain #420 1/2 Pitch x 41 Links
34	736-0921	L-Wash. 1/2" I.D.*		713-0723	#41 Master Link
35	738-0689	Shld. Bolt 1/2" Dia. x .175"	91	715-0143	Spring Spiral Pin
36	750-0539	Spacer .315" I.D.	92	731-0973	Slide Washer
37	754-0356	V-Belt	93	738-0766	Free Wheeling Axle
38	756-0536	Flat Idler 1.88" Dia.	94	741-0490	Flange Brg. w/Flats .752 I.D.
39	756-0537	Trans. Pulley 7" O.D. x 3L	95	784-5393	30 T-Sprocket Hub Ass'y.
40	784-5314	Trans. Idler Arm	96	710-0603	Hex B-Tap Scr. 5/16-18 x .5" Lg.
41	784-5315	Trans. Support Plate			
42	714-0129	Key	97	731-1042	Belt Cover
43	143.796132	Engine	98	723-0396	Tire Chains
44	710-0559	Hex Bolt 1/4-28 x 1.75" Lg.	99	726-0175	Clamp
45	736-0270	Bell-Wash. 1/4" I.D.	100	725-0157	Cable Tie
46	784-5390	Shift Arm			

*Common Hardware—May be purchased locally.

**Early Production Uses:

710-0781 Hex Wash. Hd. B-Tap Scr.
3/8-16 x .875" Lg.

SEARS CRAFTSMAN 26" SNOW THROWER MODEL NO. 247.886700

Repair Parts—Transmission Model No. 143.700031

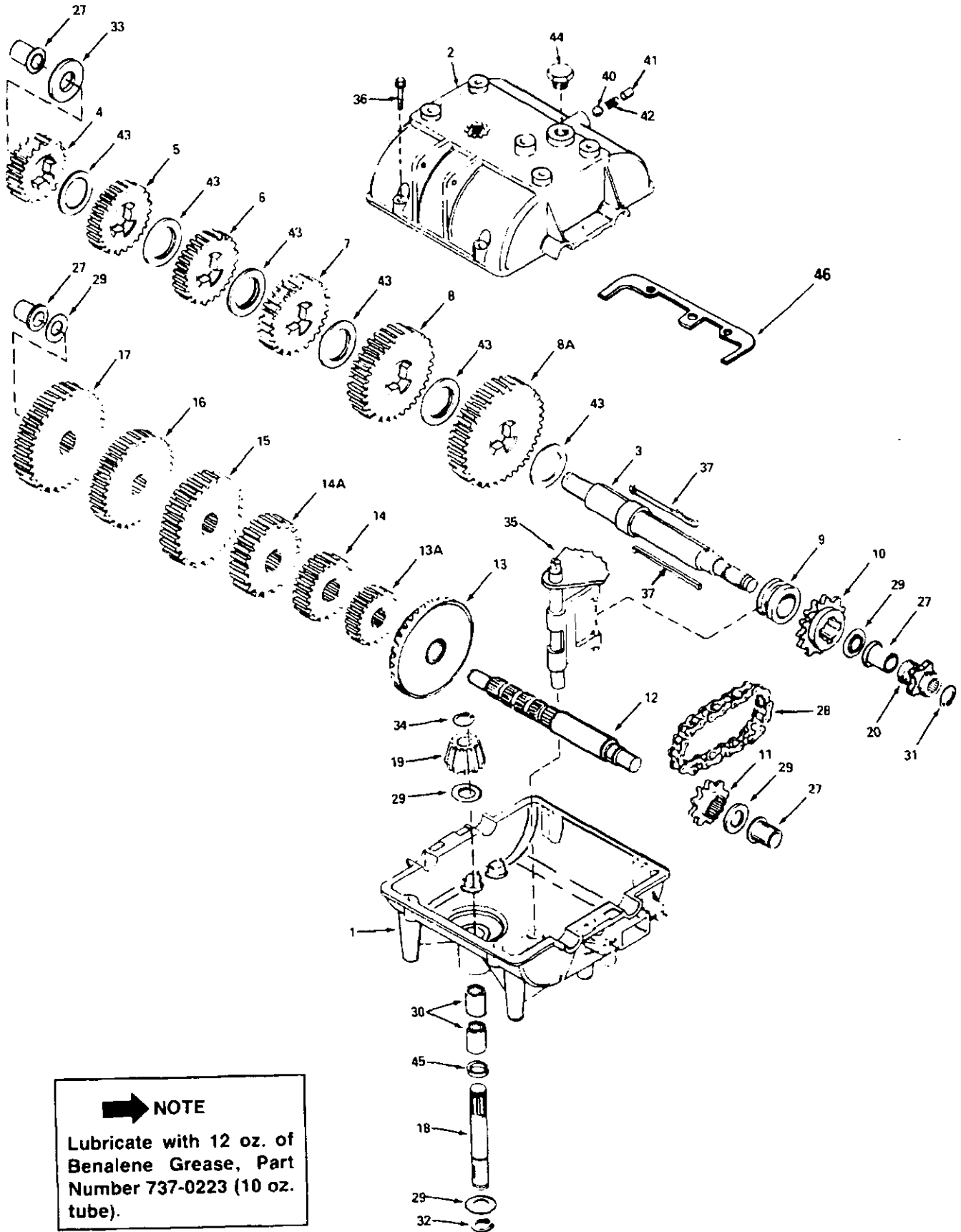

NOTE
Lubricate with 12 oz. of Benalene Grease, Part Number 737-0223 (10 oz. tube).

SEARS CRAFTSMAN 26" SNOW THROWER MODEL NO. 247.886700

Repair Parts—Transmission Model No. 143.700031

KEY NO.	PART NO.	DESCRIPTION	KEY NO.	PART NO.	DESCRIPTION
1	770061	Case, Transmission	20	786077	Sprocket (7 Teeth)
2	772083	Cover, Transmission	27	780105A	Bushing, Flanged
3	776238	Shaft, Output	28	786062A	Chain, Roller (No. 41 Chain, 22 Links)
4	778209	Gear, Spur (19 Teeth)	29	780072	Washer, Thrust
5	778190	Gear, Spur (22 Teeth)	30	780086	Bearing, Needle
6	778187	Gear, Spur (25 Teeth)	31	792072	Ring, Retaining
7	778185	Gear, Spur (30 Teeth)	32	792035	Ring, Retaining
8	778183	Gear, Spur (35 Teeth)	33	780139	Washer, Thrust
8A	778191	Gear, Spur (37 Teeth)	34	788040	Ring, Retaining
9	784266	Collar, Shift	35	784347	Rod and Fork Ass'y., Shift
10	786060	Sprocket (14 Teeth)	36	792073	Screw, Flanged Hex Hd. Thd. Forming, 1/4-20 x 1 1/4
11	786061	Sprocket (10 Teeth)	37	792089A	Key
12	776134	Shaft, Counter	40	792077	Ball, Steel, 5/16
13	778137A	Gear, Bevel (42 Teeth)	41	792078	Screw, Set, 3/8-16 x 3/8
13A	778192	Gear, Spur (12 Teeth)	42	792079	Spring
14	778193	Gear, Spur (15 Teeth)	43	780108	Wash, Thrust
14A	778184	Gear, Spur (20 Teeth)	44	792074	Plug
15	778186	Gear, Spur (25 Teeth)	45	792001	"O"-Ring
16	778189	Gear, Spur (28 Teeth)	46	788054	Gasket
17	778163	Gear, Spur (31 Teeth)	—	143.700031	Transmission
18	776140	Shaft, Input			
19	778113A	Bevel Pinion, Input			

Repair Parts

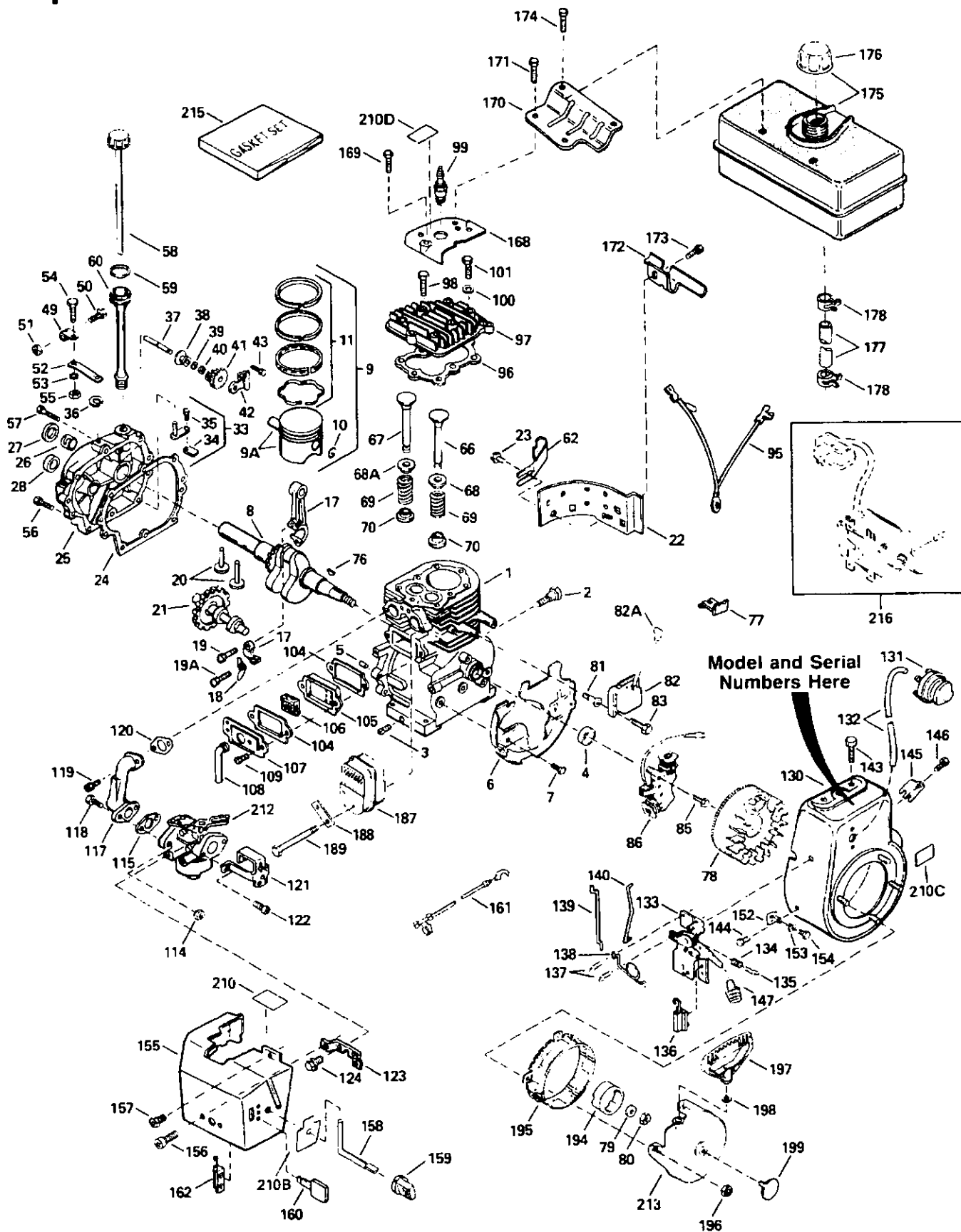

SEARS CRAFTSMAN 8 H.P. ENGINE MODEL NO. 143.796132

Repair Parts

KEY NO.	PART NO.	DESCRIPTION	KEY NO.	PART NO.	DESCRIPTION
1	35385	Cylinder (Incl. Nos. 3, 4 & 5)	50	29826	Screw, Hex Washer Hd., 10-32 x 3/4
2	650820	Screw, Hex Hd. Shoulder, 1/4-20 x 1/2	51	29216	Locknut, Hex "Keps," 10-32
3	27642	Plug, Pipe	52	33454	Lever, Governor
4	35319	Seal, Oil	53	29918	Washer, E.T. Lock
5	27652	Pin, Dowel	54	650548	Screw, Hex Washer Hd., 8-32 x 5/16
6	35326	Baffle, Blower Housing	55	30322	Locknut, Hex "Keps," 8-32
7	650561	Screw, Hex Wash. HD. Durlok, 1/4-20 x 5/8	56	650832	Screw, Hex Washer Hd. Powerlok, 1/4-20 x 1-11/16
8	35372	Crankshaft	57	650833	Screw, Hex Washer Hd. Powerlok, 1/4-20 x 1-3/16
9	34552	Piston, Pin & Ring Ass'y. (Incl. Nos. 9A, 10 & 11) (Std.)	58	35555	Dipstick, Oil
9	34553	Piston, Pin & Ring Ass'y. (Incl. Nos. 9A, 10 & 11) (.010 Oversize)	59	35499	"O" Ring
9	34554	Piston, Pin & Ring Ass'y. (Incl. Nos. 9A, 10 & 11) (.020 Oversize)	60	35554	Tube, Oil Fill
9A	34329A	Piston & Pin Ass'y. (Incl. No. 10) (Std.)	62	35540	Clip, Fill Tube
9A	34330A	Piston & Pin Ass'y. (Incl. No. 10) (.010 Oversize)	66	27878A	Valve, Exhaust (Incl. No. 70) (Std.)
9A	34331A	Piston & Pin Ass'y. (Incl. No. 10) (.020 Oversize)	66	27880A	Valve, Exhaust (Incl. No. 70) (1/32" Oversize)
10	27888	Ring, Piston Pin Retaining	67	34035	Valve, Intake (Incl. No. 70) (Std.)
11	34332	Ring Set, Piston (Std.)	67	34036	Valve, Intake (Incl. No. 70) (1/32" Oversize)
11	34333	Ring Set, Piston (.010 Oversize)	68	27882	Cap, Upper Valve Spring
11	34334	Ring Set, Piston (.020 Oversize)	68A	34689	Seal Ass'y., Intake Valve
17	35373A	Rod Ass'y., Connecting (Incl. Nos. 18, 19 & 19A)	69	27881	Spring, Valve
18	35374	Dipper, Oil	70	32581	Cap, Lower Valve Spring
19	650908	Bolt, Connecting Rod	76	32589	Key, Flywheel
19A	650882	Bolt, Connecting Rod	77	29443	Clip, Spring
20	34034	Lifter, Valve	78	611093	Flywheel (w/Ring Gear)
21	35444	Camshaft (Mechanical Compression Release)	79	650880	Washer, Lock
22	33273A	Extension, Blower Housing	80	650881	Nut, Flywheel
23	650128	Screw, Hex Hd. Sems, 10-24 x 1/2	81	650872	Stud, Solid State Mounting
24	*35262	Gasket, Cylinder Cover	82	35135	Solid State Ass'y.
25	35445	Cover Ass'y., Cylinder (Incl. Nos. 26, 27 & 37)	82A	610118	Cover, Spark Plug
26	35377	Bushing, Crankshaft	83	650814	Screw, Hex Hd. Sems, 10-24 x 1
27	35319	Seal, Oil	85	650873	Screw, Hex Hd. Sems, 1/4-20 x 3/4
28	28926	Seal, Oil (Camshaft)	86	611111	Coil Ass'y., Alternator (18 Watt)
33	30699C	Rod Ass'y., Governor (Incl. Nos. 34 & 35)	95	35253	Wire, Ground
34	30700	Yoke, Governor	96	*34041	Gasket, Cylinder Head
35	650494	Screw, Fil. Hd. Sems, 6-40 x 5/16	97	34030	Head, Cylinder
36	29642	Ring, Retaining	98	6021A	Screw, Hex Flange Hd. 5/16-18 x 1 1/2
37	31845	Shaft, Governor	99	33636	Spark Plug (Champion J-8C or Equivalent)
38	30588A	Spool, Governor	100	650691	Washer, Flat
39	30590A	Washer, Flat	101	650727	Screw, Special Hex Hd. Tapped, 5/16-18 x 1 3/4
40	29193	Ring, Retaining	104	*27896	Gasket, Breather
41	35378	Gear, Governor (Incl. No. 39)	105	28423	Body, Breather
42	33369	Bracket, Governor Gear	106	28424	Element, Breather
43	650836	Screw, Hex Washer Hd. Thd. Forming, 10-24 x 1/2	107	28425	Cover, Breather
49	29916	Clamp, Governor Lever	108	35350	Tube, Breather
			109	650128	Screw, Hex Hd. Sems, 10-24 x 1/2
			114	29752	Nut & Lock Washer, 1/4-28
			115	*33263	Gasket, Carburetor
			117	33877	Pipe, Intake
			118	30088A	Screw, Fil. Hd. Sems, 1/4-28 x 1

*Indicates Parts Included in

SEARS CRAFTSMAN 8 H.P. ENGINE MODEL NO. 143.796132

Repair Parts

KEY NO.	PART NO.	DESCRIPTION	KEY NO.	PART NO.	DESCRIPTION
119	650378	Screw, Torx Fil. Hd. Sems, 5/16-18 x 1-1/8	159	35438	Knob, Choke
120	*27915	Gasket, Intake Pipe	160	35593	Ignition, Key
121	34587	Bracket, Choke	161	35305	Wire, Ground
122	28820	Screw, Fil. Hd. Sems, 10-32 x 1/2	162	610973	Terminal Ass'y.
123	33377	Bracket, Carburetor Cover Mounting	168	33272A	Cover, Cylinder Head
124	650767	Screw, Hex Washer Hd. Sems, Taptite, 8-36 x 5/8	169	650802	Screw, Hex Washer Hd. Taptite, 1/4-20 x 5/8
130	34822A	Housing, Blower	170	34154	Plate, Fuel Tank Mounting
131	570682	Primer Ass'y.	171	650713	Screw, Hex Hd., 5/16-18 x 5/8
132	32180C	Line, Primer	172	34155	Bracket, Fuel Tank
133	34664	Bracket Ass'y., Control (Incl. Nos. 134, 135, 136 & 138)	173	650561	Screw, Hex Washer Hd. Durlok, 1/4-20 x 5/8
134	31342	Spring, Compression	174	650665	Screw, Hex Washer Hd. Thread Cutting, 1/4-15 x 7/8
135	650549	Screw, Fil. Hd., 5-40 x 7/16	175	34156A	Tank, Fuel (Incl. Nos. 176 & 178)
136	610973	Terminal Ass'y.	176	35355	Cap, Fuel Tank
137	650821	Screw, Hex Washer Hd. Thread Cutting, 10-32 x 1/2	177	30705	Line, Fuel
138	34663	Spring, Speed Control	178	26460	Clamp, Fuel Line
139	34667	Link, Governor	187	35056	Muffler
140	33878	Link, Governor-to-Throttle	188	31588	Plate, Lock
143	650788	Screw, Hex Hd. Spinlock Thread Forming, 5/16-18 x 3/4	189	792093	Screw, Flanged Hex Hd., 5/16-18 x 4-3/16
144	29747B	Screw, Phil. Hex Hd. Sems, 5/16-24 x 21/32	194	35287	Hub, Starter
145	33013	Cover, Starter Hole	195	35446	Screen, Starter
146	650760	Screw, Pan Hd. Taptite, 8-32 x 3/8	196	29752	Nut & Lock Washer, 1/4-28
147	35440	Knob, Control	197	590574	Starter Handle, Mitten Grip
152	34126	Bracket, Grommet Mounting	198	650168	Washer, Flat
153	28545	Grommet, Plastic	199	35392	Plug, Starter
154	650760	Screw, Pan Hd. Taptite, 8-32 x 3/8	210	34346	Decal, Instruction
155	35057	Cover, Carburetor	210B	35077	Decal, Choke
156	28942	Screw, Hex Washer Hd. Sems, 10-32 x 3/8	210C	34144	Decal, Primer
157	650765	Screw, Hex Washer Hd. Self- Drilling, 10-32 x 1/2	210D	34414	Decal, Warning (Bilingual)
158	34586	Rod, Choke	212	632334	Carburetor (Incl. No. 115)
			213	590630	Starter, Rewind
			215	33279F	Gasket Set (Incl. Items Marked *)
			216		Electric Start Kit No. 143.88924 (Optional) Order as an accessory.

*Indicates Parts Included in
Gasket Set, Ref. No. 215.

Repair Parts

PARTS LIST FOR CARBURETOR

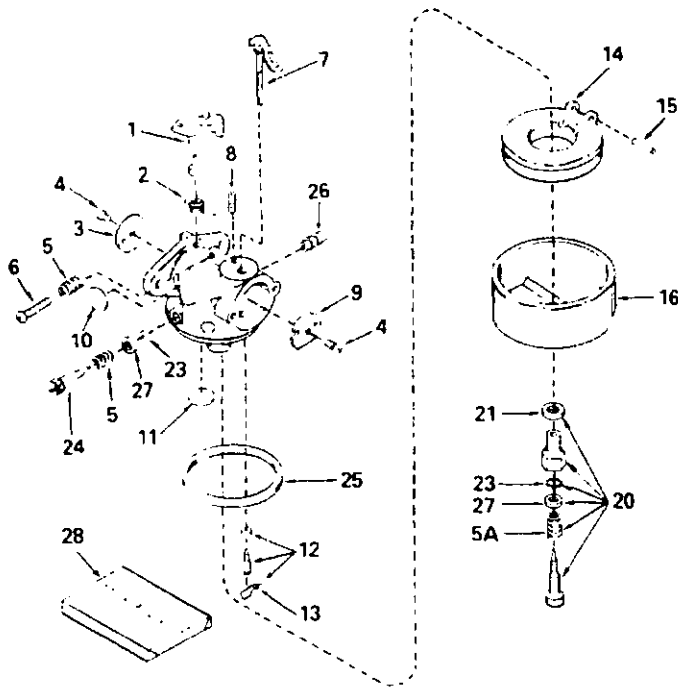

KEY NO.	PART NO.	DESCRIPTION
1	631776	Shaft & Lever Ass'y, Throttle
2	631970	Spring, Throttle Return
3	631778	Shutter, Throttle
4	650506	Screw, Throttle & Choke Shutter
5	630766	Spring, Regulating Screw
5A	630738	Spring, Main Adjustment Screw
6	650417	Screw, Idle Regulating
7	632112	Shaft & Lever Ass'y., Choke
8	630735	Spring, Choke Positioning
9	632174	Shutter, Choke
10	*630748	Plug, Welch
11	*631027	Plug, Welch
12	*631021	Inlet Needle, Seat & Clip Ass'y. (Incl. No. 13)
13	631022	Clip, Inlet Needle
14	632019	Float, Carburetor
15	*631024	Shaft, Float
16	631867	Bowl, Float
20	*632239	Adjustment Screw Ass'y., Main (Incl. Nos. 5A, 21, 23 & 27)
21	27110	Gasket, Bowl-to-Body
23	*630740	"O" Ring, Adjustment Screw
24	*630898	Screw, Idle Adjustment
25	*631028	Gasket, Bowl-to-Body
26	632164	Fitting, Fuel Inlet
27	630739	Washer
28	632240	Repair Kit (Incl. Items Marked *)
—	632334	Carburetor, Comp.

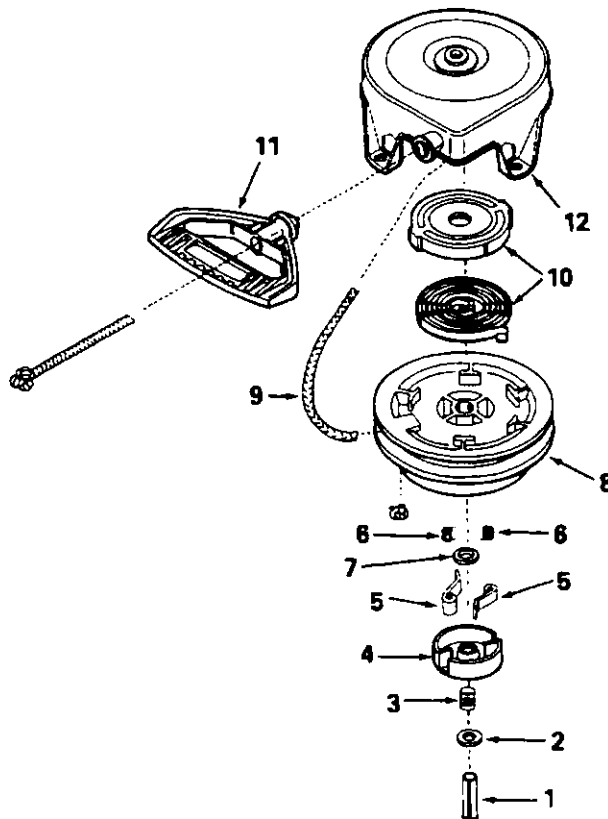

PARTS LIST FOR REWIND STARTER

KEY NO.	PART NO.	DESCRIPTION
1	590599A	Pin, Spring (Incl. No. 7)
2	590600	Washer
3	590598	Spring, Brake
4	590627	Retainer
5	590641	Dog, Starter
6	590617	Spring, Dog
6	590601	Washer
8	590628	Pulley
9	590451A	Rope, Starter
10	590629	Spring & Keeper Ass'y.
11	590574	Handle, Mitten Grip (Not Included w/Starter)
12	590631	Housing Ass'y., Starter
—	590630	Rewind Starter Comp.

SEARS CRAFTSMAN OPTIONAL 120 VOLT ELECTRIC STARTER KIT NO. 143.88924

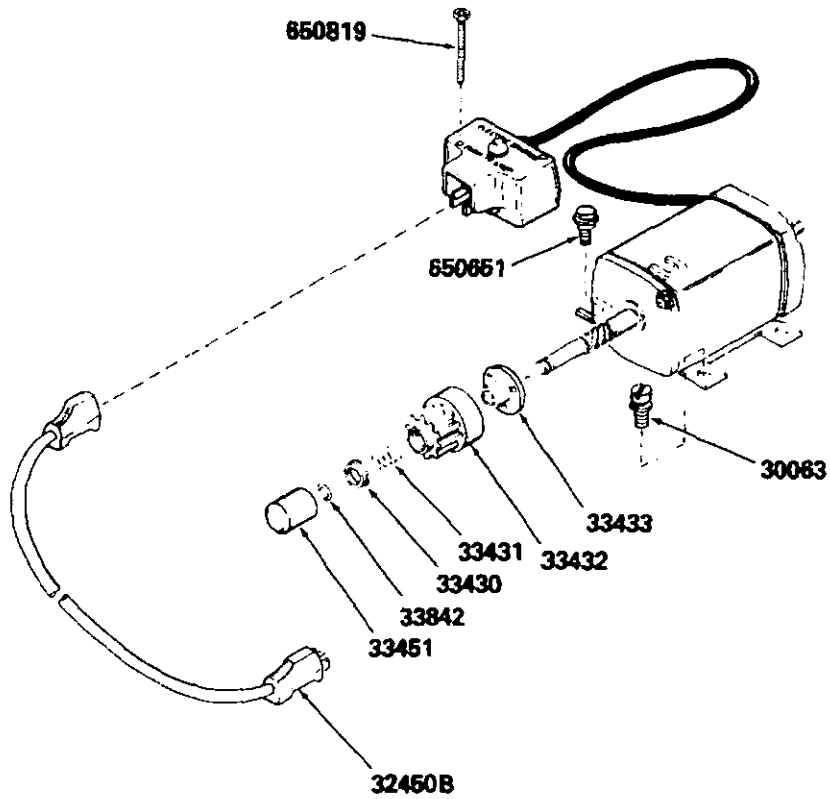

10

11

12

SEARS

owner's
manual

**MODEL NO.
247.886700**

**SEARS
SERVICE
is at
YOUR
SERVICE**

HOW TO ORDER REPAIR PARTS

Each SNOW THROWER has its own MODEL NUMBER.
Each ENGINE has its own MODEL NUMBER.

The MODEL NUMBER for the ENGINE will be found on the ENGINE BLOWER HOUSING.

Always mention these MODEL NUMBERS when requesting service or Repair Parts for your SNOW THROWER.

All parts listed herein may be ordered through any Sears Service Center/Departments and most Sears Stores.

WHEN ORDERING REPAIR PARTS, ALWAYS GIVE THE FOLLOWING INFORMATION:

1. PART NUMBER
2. PART DESCRIPTION
3. MODEL NUMBER — **247.886700**
4. NAME OF THE ITEM — **SNOW THROWER**
5. ENGINE MODEL NUMBER — **143.796132**

"Your Sears merchandise has added value when you consider that Sears has service units nationwide staffed with Sears trained technicians . . . professional technicians specifically trained on Sears products, having the parts, tools and equipment to insure that we meet our pledge to you . . . we service what we sell."

Sold by Sears, Roebuck and Co., Chicago, IL 60684