

# Reebok®

## 365 TR

Model No. RBEX71507.0

Serial No. \_\_\_\_\_

Write the serial number in the space above for future reference.

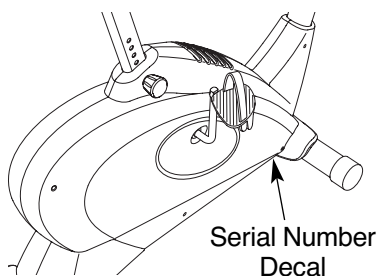

## USER'S MANUAL

### QUESTIONS?

As a manufacturer, we are committed to providing complete customer satisfaction. If you have questions, or if parts are damaged or missing, **PLEASE DO NOT CONTACT THE STORE; please contact Customer Care.**

**IMPORTANT:** You must note the product model number and serial number (see the drawing above) before contacting us.

CALL TOLL-FREE:

**1-877-994-4999**

Mon.–Fri. 6 a.m.–6 p.m. MST

Sat. 8 a.m.–4 p.m. MST

ON THE WEB:

[www.reebokservice.com](http://www.reebokservice.com)

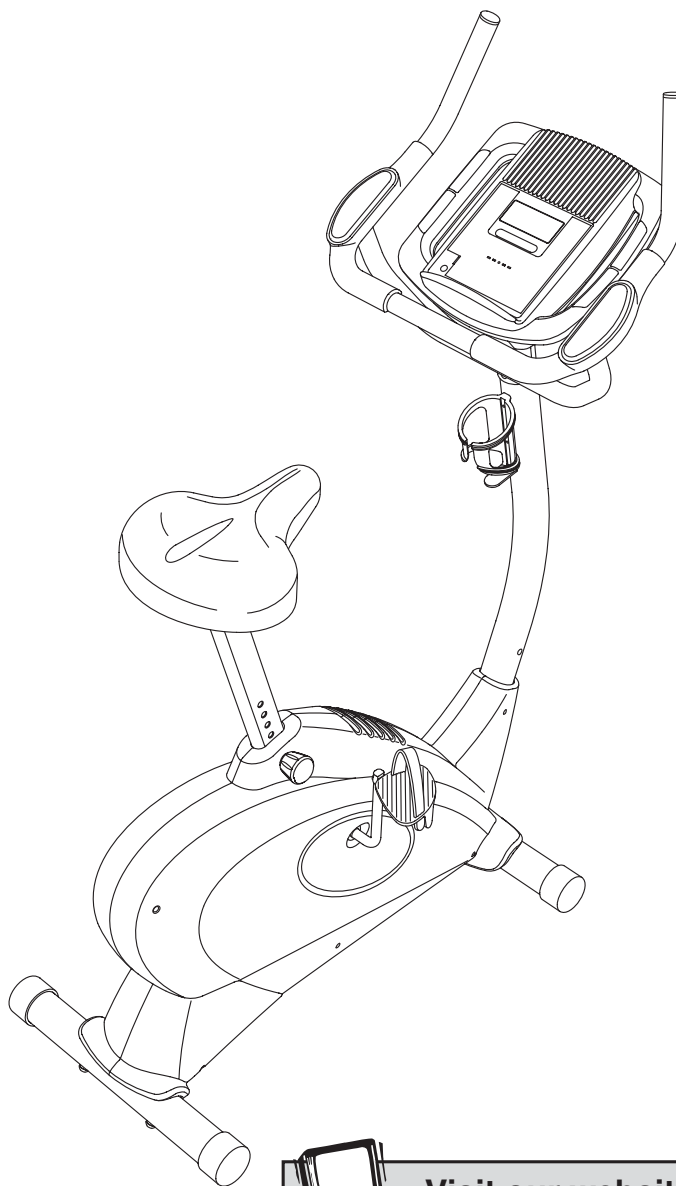

### ⚠ CAUTION

Read all precautions and instructions in this manual before using this equipment. Keep this manual for future reference.



Visit our website at

[www.reebokhomefitness.com](http://www.reebokhomefitness.com)

new products, prizes,  
fitness tips, and much more!

# TABLE OF CONTENTS

WARNING DECAL PLACEMENT .....	.2
IMPORTANT PRECAUTIONS .....	.3
BEFORE YOU BEGIN .....	.4
ASSEMBLY .....	.5
HOW TO OPERATE THE EXERCISE CYCLE .....	.10
MAINTENANCE AND TROUBLESHOOTING .....	.15
EXERCISE GUIDELINES .....	.16
PART LIST .....	.18
EXPLODED DRAWING .....	.19
ORDERING REPLACEMENT PARTS .....	.Back Cover
LIMITED WARRANTY .....	.Back Cover

## WARNING DECAL PLACEMENT

The warning decal shown here has been applied in the location shown. **If the decal is missing or illegible, call the telephone number on the front cover of this manual and request a free replacement decal. Apply the decal in the location shown.**

Note: The decal may not be shown at actual size.

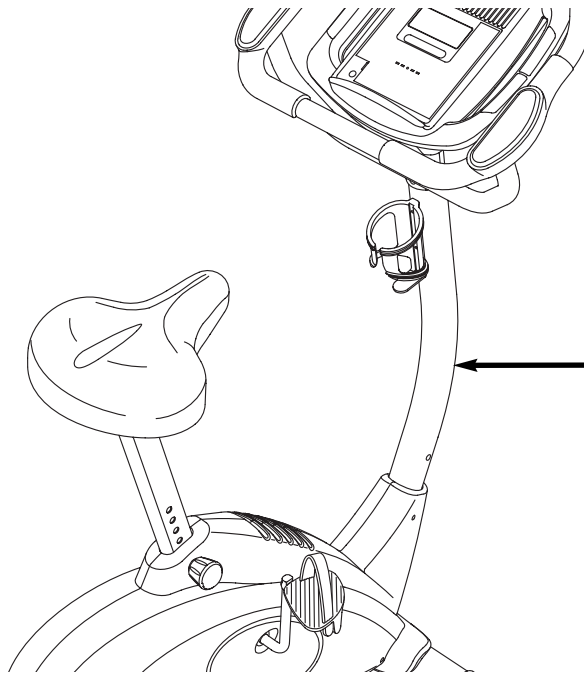

**⚠ WARNING**

- Misuse of this machine may result in serious injury.
- Read user's manual prior to use and follow all warnings and instructions.
- Do not allow children on or around machine.
- Pedals continue to spin when you stop pedaling.
- Spinning pedals can cause injury.
- Reduce pedal speed in a controlled manner.
- User weight must not exceed 250 pounds.
- Replace label if damaged, illegible, or removed.

# IMPORTANT PRECAUTIONS

**⚠ WARNING:** To reduce the risk of serious injury, read all important precautions and instructions in this manual and all warnings on your exercise cycle before using your exercise cycle. ICON assumes no responsibility for personal injury or property damage sustained by or through the use of this product.

1. Before beginning any exercise program, consult your physician. This is especially important for persons over the age of 35 or persons with pre-existing health problems.
2. It is the responsibility of the owner to ensure that all users of the exercise cycle are adequately informed of all precautions.
3. Your exercise cycle is intended for home use only. Do not use your exercise cycle in a commercial, rental, or institutional setting.
4. Keep your exercise cycle indoors, away from moisture and dust. Place your exercise cycle on a level surface, with a mat beneath it to protect the floor or carpet. Make sure that there is enough clearance around your exercise cycle to mount, dismount, and use it.
5. Inspect and properly tighten all parts regularly. Replace any worn parts immediately.
6. Keep children under age 12 and pets away from your exercise cycle at all times.
7. Your exercise cycle should not be used by persons weighing more than 250 lbs. (113 kg).
8. Wear appropriate exercise clothes while exercising; do not wear loose clothes that could become caught on your exercise cycle. Always wear athletic shoes for foot protection while exercising.
9. When adjusting the seat, insert the adjustment knob into one of the holes in the seat post. Do not insert the seat pin under the seat post.
10. The pulse sensor is not a medical device. Various factors, including the user's movement, may affect the accuracy of heart rate readings. The pulse sensor is intended only as an exercise aid in determining heart rate trends in general.
11. Keep your back straight while using your exercise cycle; do not arch your back.
12. When you stop exercising, allow the pedals to slowly come to a stop.
13. If you feel pain or dizziness while exercising, stop immediately and cool down.
14. Use your exercise cycle only as described in this manual.

# BEFORE YOU BEGIN

Congratulations for selecting the new REEBOK® 365 TR exercise cycle. Cycling is one of the most effective exercises for increasing cardiovascular fitness, building endurance, and toning the entire body. The 365 TR exercise cycle offers a selection of features designed to let you enjoy this healthful exercise in the convenience and privacy of your home.

**For your benefit, read this manual carefully before you use the exercise cycle.** If you have questions after reading this manual, please see the front cover of this manual. To help us assist you, note the product

model number and serial number before contacting us. The model number and the location of the serial number decal are shown on the front cover of this manual.

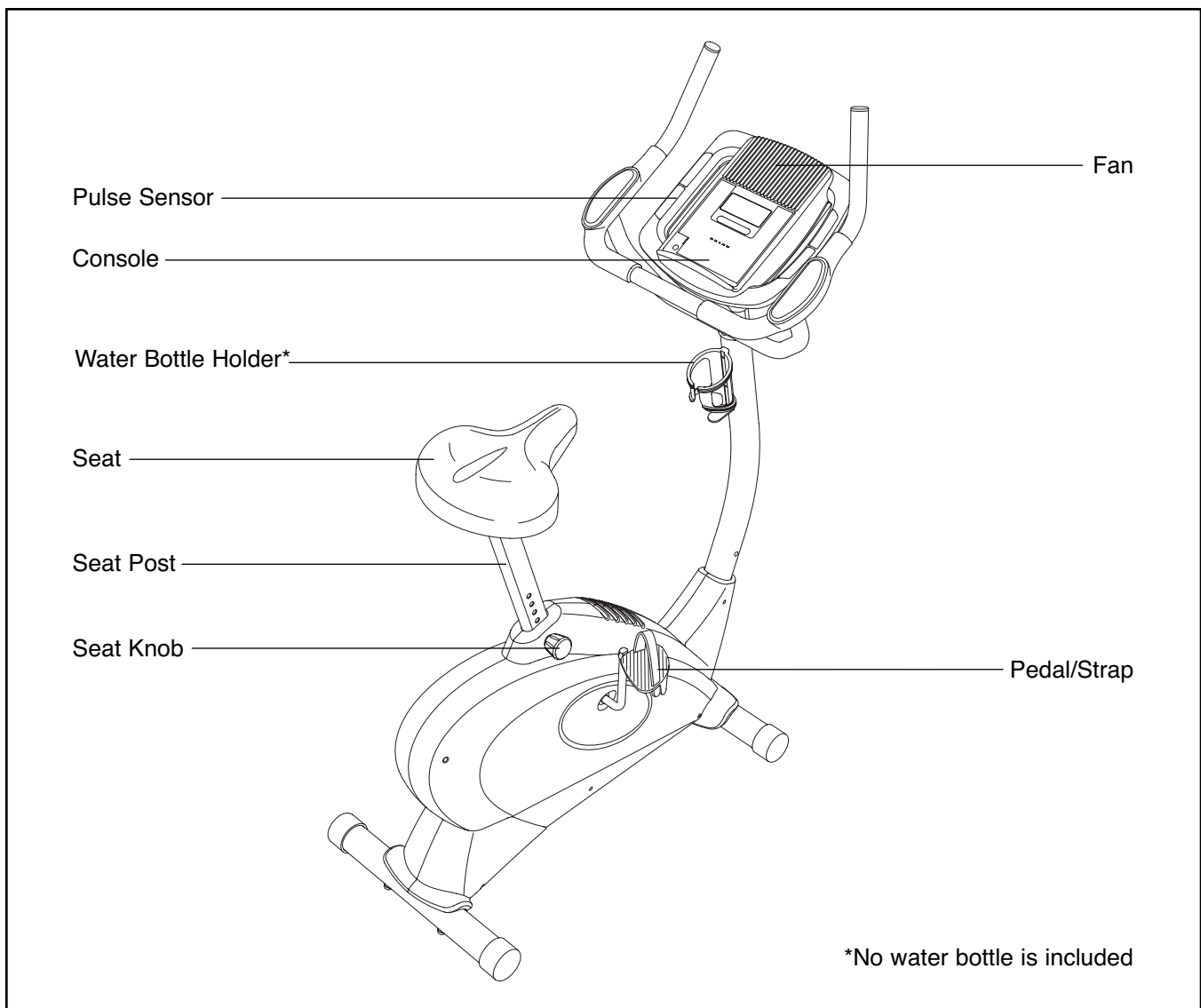

**To avoid a registration fee for any service needed under warranty, you must register the exercise cycle at [www.reebokservice.com/registration](http://www.reebokservice.com/registration).**

Before reading further, please familiarize yourself with the parts that are labeled in the drawing below.



# ASSEMBLY

To hire an authorized service technician to assemble the exercise cycle, call toll-free 1-800-445-2480.

**Assembly requires two persons.** Place all parts of the exercise cycle in a cleared area and remove the packing materials. Do not dispose of the packing materials until assembly is completed. **Assembly requires the included tools and your own adjustable wrench**  **and Phillips screwdriver**  .

Use the part drawings below to identify the small parts used in assembly. The number in parentheses below each drawing refers to the key number of the part, from the PART LIST near the end of this manual. The number following the parentheses is the quantity needed for assembly. **Note: Some small parts may have been pre-assembled. If a part is not in the parts bag, check to see if it has been preassembled.**

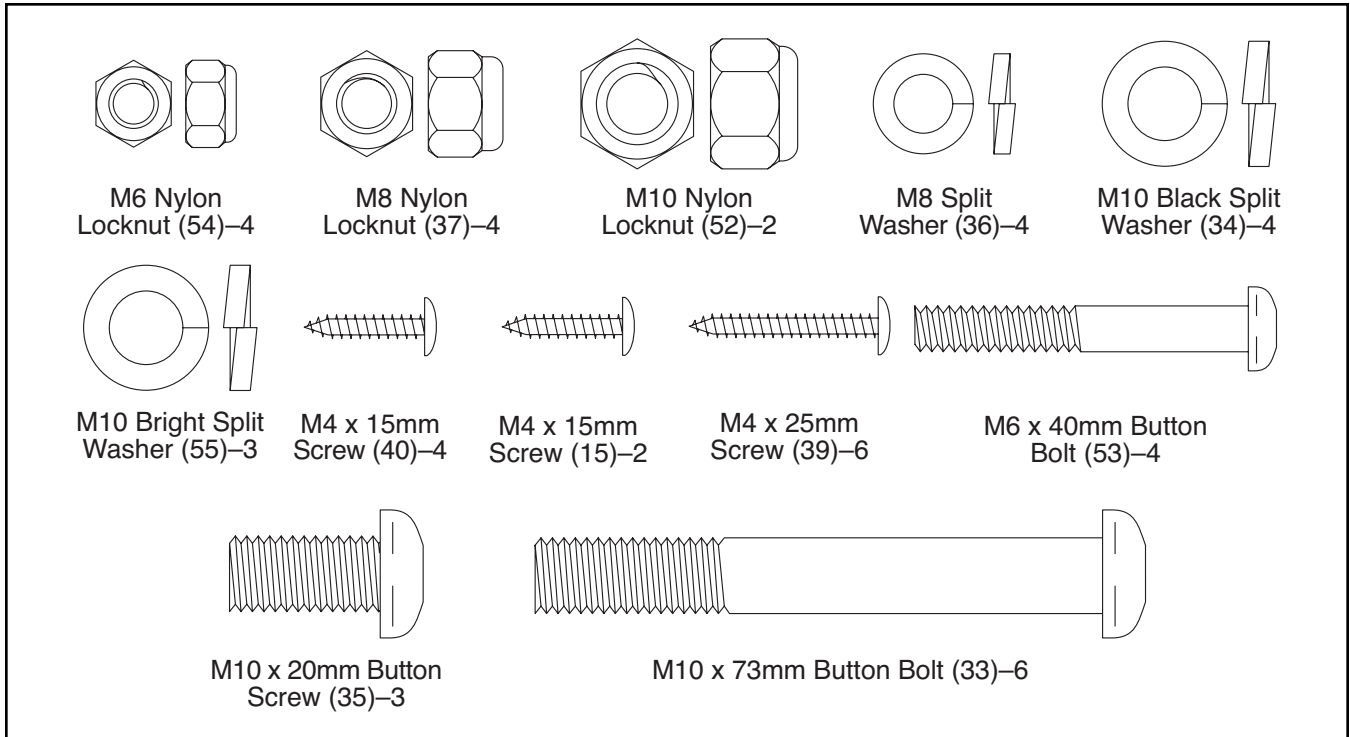

1. Identify the Front Stabilizer (2), which is narrower than the Rear Stabilizer (not shown). While another person lifts the front of the Frame (1), attach the Front Stabilizer to the Frame with two M10 x 73mm Button Bolts (33) and two M10 Black Split Washers (34).

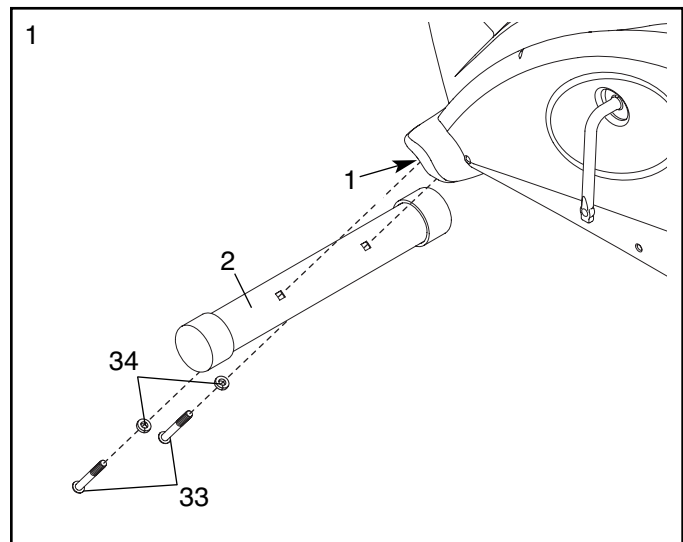

2. While another person lifts the rear of the Frame (1), attach the Rear Stabilizer (14) to the Frame with two M10 x 73mm Button Bolts (33) and two M10 Black Split Washers (34).

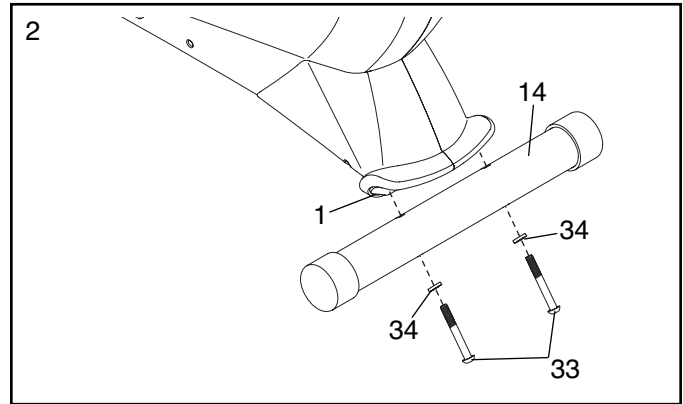

3. While another person holds the Upright (3) near the Frame (1), connect the Upper Wire Harness (32) to the Lower Wire Harness (31).

**Tip: Avoid pinching the wire harnesses during this step.** Gently pull the upper end of the Upper Wire Harness (32) to remove the slack, and slide the Upright (3) onto the Frame (1). Attach the Upright with three M10 x 20mm Button Screws (35) and three M10 Bright Split Washers (55).

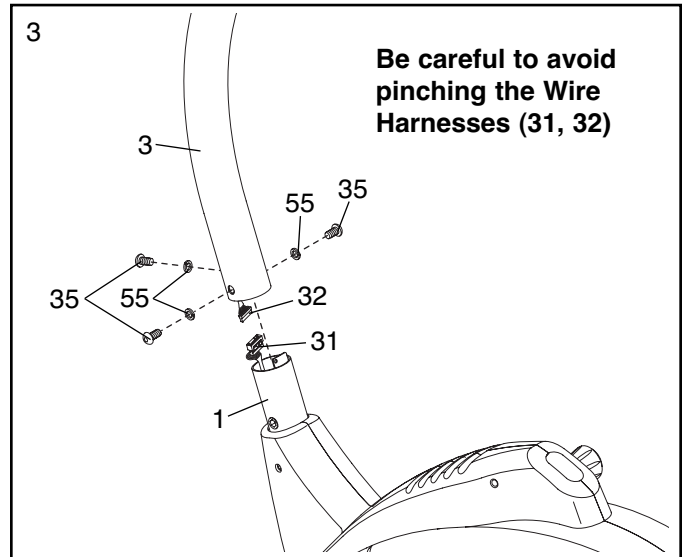

4. Attach the Water Bottle Holder (29) to the Upright (3) with two M4 x 15mm Screws (15).

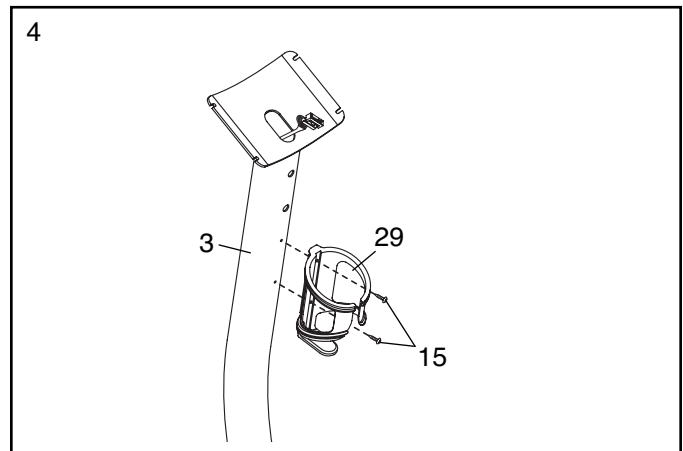

5. Attach the Handlebar (47) to the Handlebar Bracket (48) with four M6 x 40mm Button Bolts (53) and four M6 Nylon Locknuts (54).

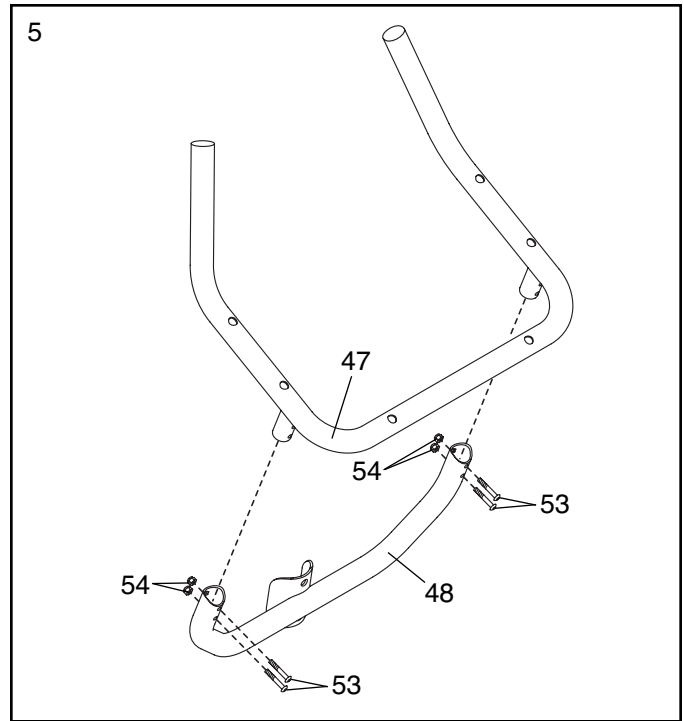

6. Attach the Left Arm Pad (49) to the Handlebar (47) with three M4 x 25mm Screws (39).

**Attach the Right Arm Pad (50) in the same way.**

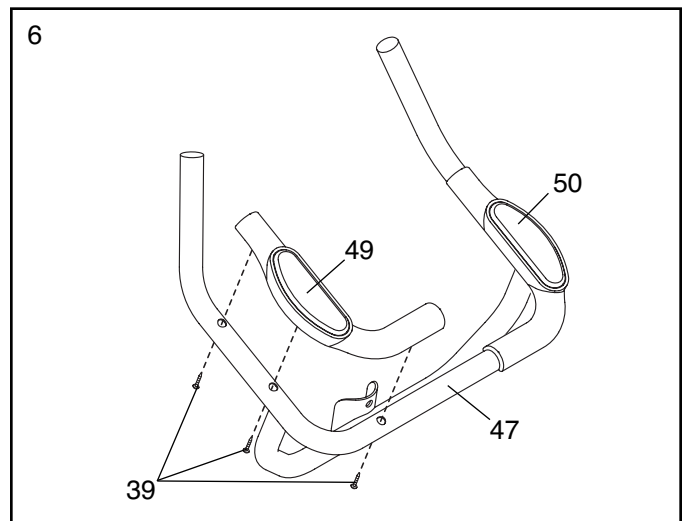

7. Attach the Handlebar Bracket (48) to the Upright (3) with two M10 x 73mm Button Bolts (33) and two M10 Nylon Locknuts (52).

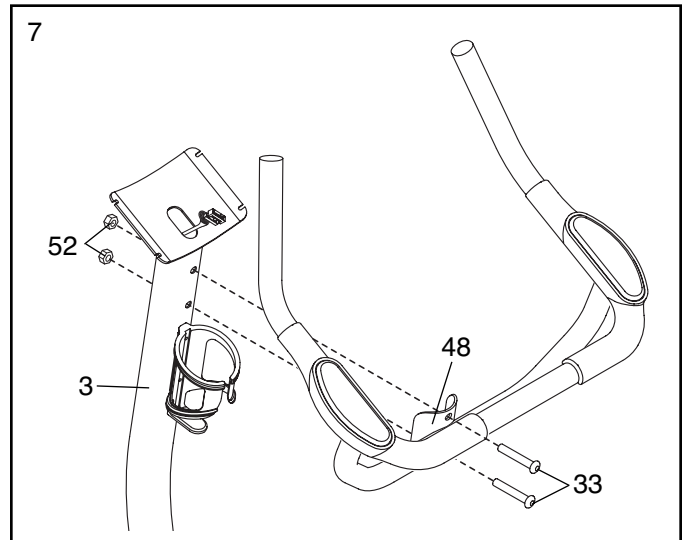

8. The Console (6) can be operated with four 1.5V “D” batteries (not included); alkaline batteries are recommended. **IMPORTANT: If the exercise cycle has been exposed to cold temperatures, allow it to warm to room temperature before inserting batteries into the Console. If you do not do this, the console displays or other electronic components may become damaged.** Press the tab on the battery cover and remove the battery cover. Insert four batteries into the console; **make sure that the batteries are oriented as shown.** Then, reattach the battery cover.

The Console (6) can also be operated with an optional power supply (not included). **To purchase a power supply, call the telephone number on the front cover of this manual. To avoid damaging the console, use only a manufacturer-supplied power supply.** Plug one end of the power supply into the jack on the console; plug the other end into an outlet installed in accordance with all local codes and ordinances.

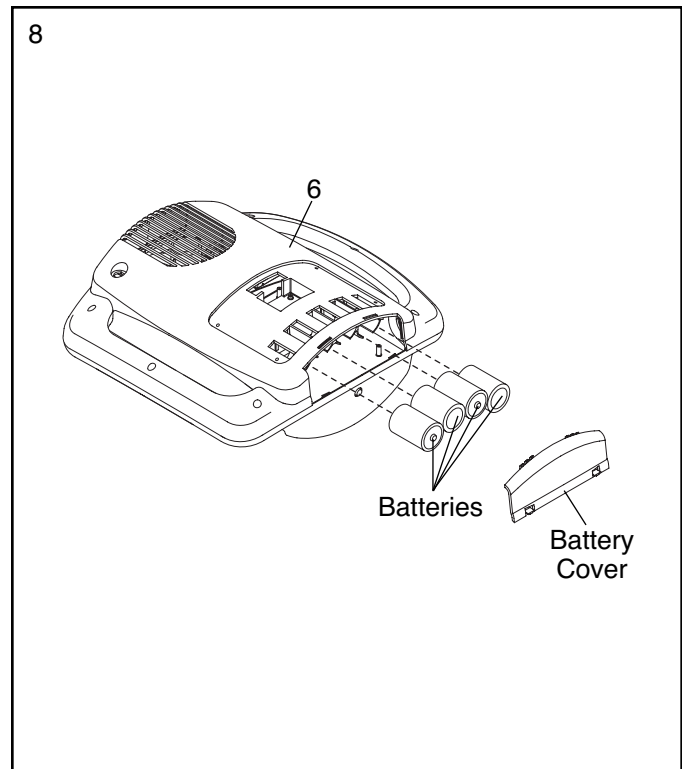

9. While another person holds the Console (6) near the Upright (3), connect the console wire harness to the Upper Wire Harness (32).

**Tip: Start all screws before tightening any of them. Also, avoid pinching the Wire Harness during this step.** Insert the excess Wire Harness (32) downward into the Upright (3). Attach the Console (6) to the Upright with four M4 x 15mm Screws (40).

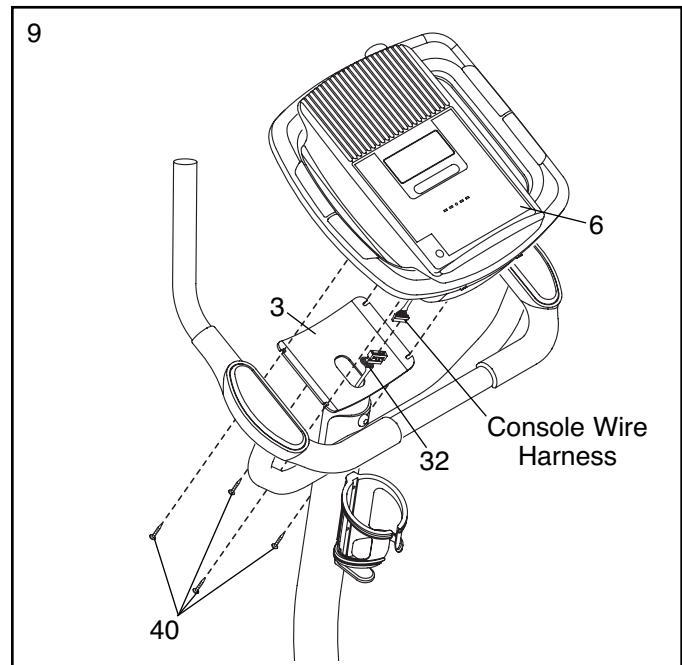



10. Attach the Seat (12) to the Seat Post (5) with four M8 Nylon Locknuts (37) and four M8 Split Washers (36). **Note: The Nylon Locknuts and Split Washers may be pre-attached to the Seat.**

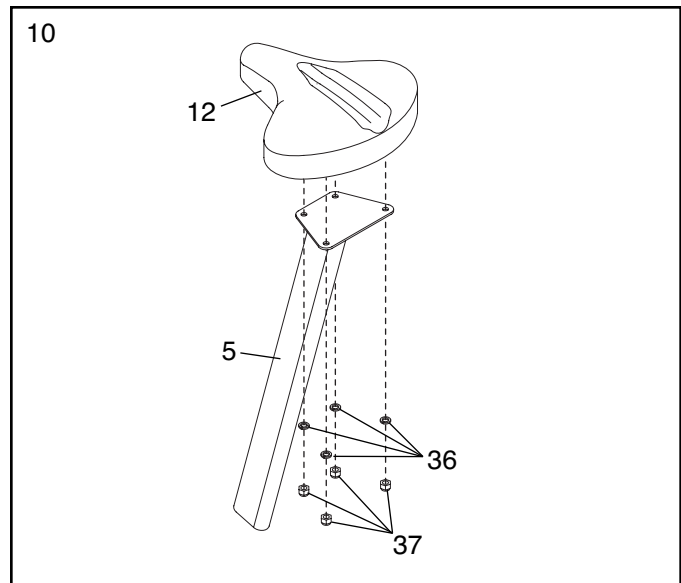

11. Remove the packing tube from the Frame (1), and discard the packing tube.

Turn the Seat Knob (11) counterclockwise two or three turns to loosen it (if the Seat Knob is not loosened enough, it may scratch the Seat Post [5]). Next, pull the Seat Knob, insert the Seat Post into the Frame (1), and then release the Seat Knob. **Move the Seat Post upward and downward slightly until the pin on the Seat Knob snaps into one of the holes in the Seat Post.** Then, turn the Seat Knob clockwise until it is tight.

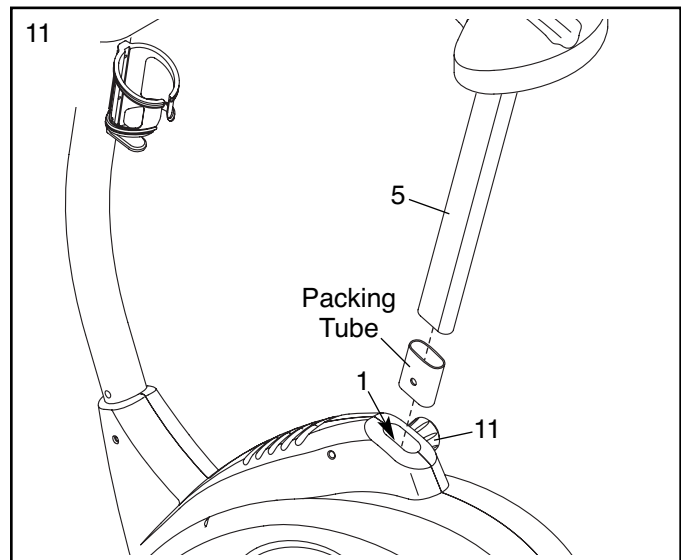

12. Identify the Left Pedal (24), which is marked with an "L." Using an adjustable wrench, **firmly tighten** the Left Pedal *counterclockwise* into the left arm of the Crank (13). Tighten the Right Pedal (not shown) *clockwise* into the right arm of the Crank. **IMPORTANT: Tighten both Pedals as firmly as possible. After using the exercise cycle for one week, retighten the Pedals. For best performance, keep the Pedals tightened.**

Adjust the strap on the Left Pedal (24) to the desired position, and press the end of the strap onto the tab on the side of the Left Pedal. Adjust the strap on the Right Pedal (not shown) in the same way.

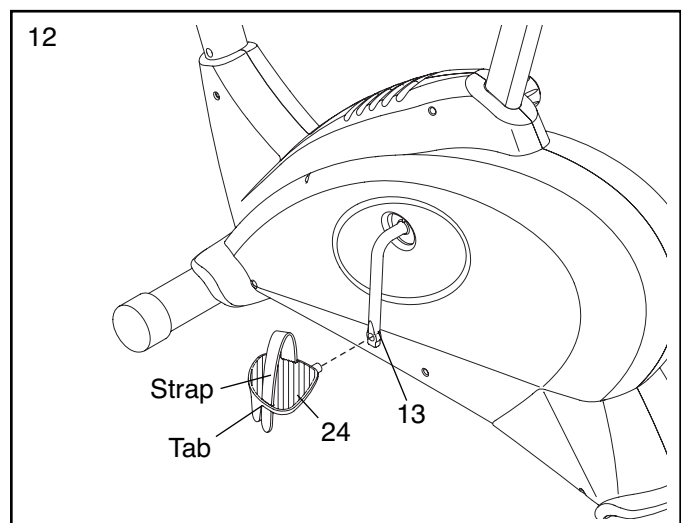

13. **Make sure that all parts are properly tightened before you use the exercise cycle.** Note: After assembly is completed, some extra parts may be left over. Place a mat beneath the exercise cycle to protect the floor.

# HOW TO OPERATE THE EXERCISE CYCLE

## HOW TO ADJUST THE SEAT

For effective exercise, the seat should be at the proper height. As you pedal, there should be a slight bend in your knees when the pedals are in the lowest position. To adjust the height of the seat, first turn the seat knob counter-clockwise two or three turns to loosen it (if the knob is not loosened enough, it may scratch the seat post). Next, pull the knob, slide the seat post to the desired height, and then release the knob. **Move the seat post up and down slightly until the pin on the knob snaps into one of the holes in the seat post.** Then, turn the knob clockwise until it is tight.

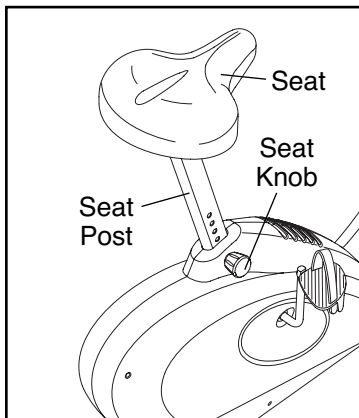

## HOW TO ADJUST THE PEDAL STRAPS

To adjust the pedal straps, first pull the ends of the pedal straps off the tabs on the pedals. Adjust the pedal straps to the desired position, and then press the ends of the pedal straps back onto the tabs.

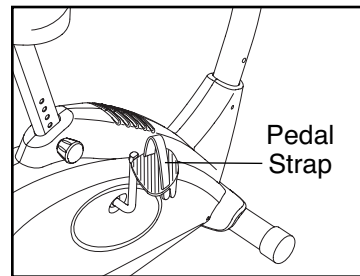

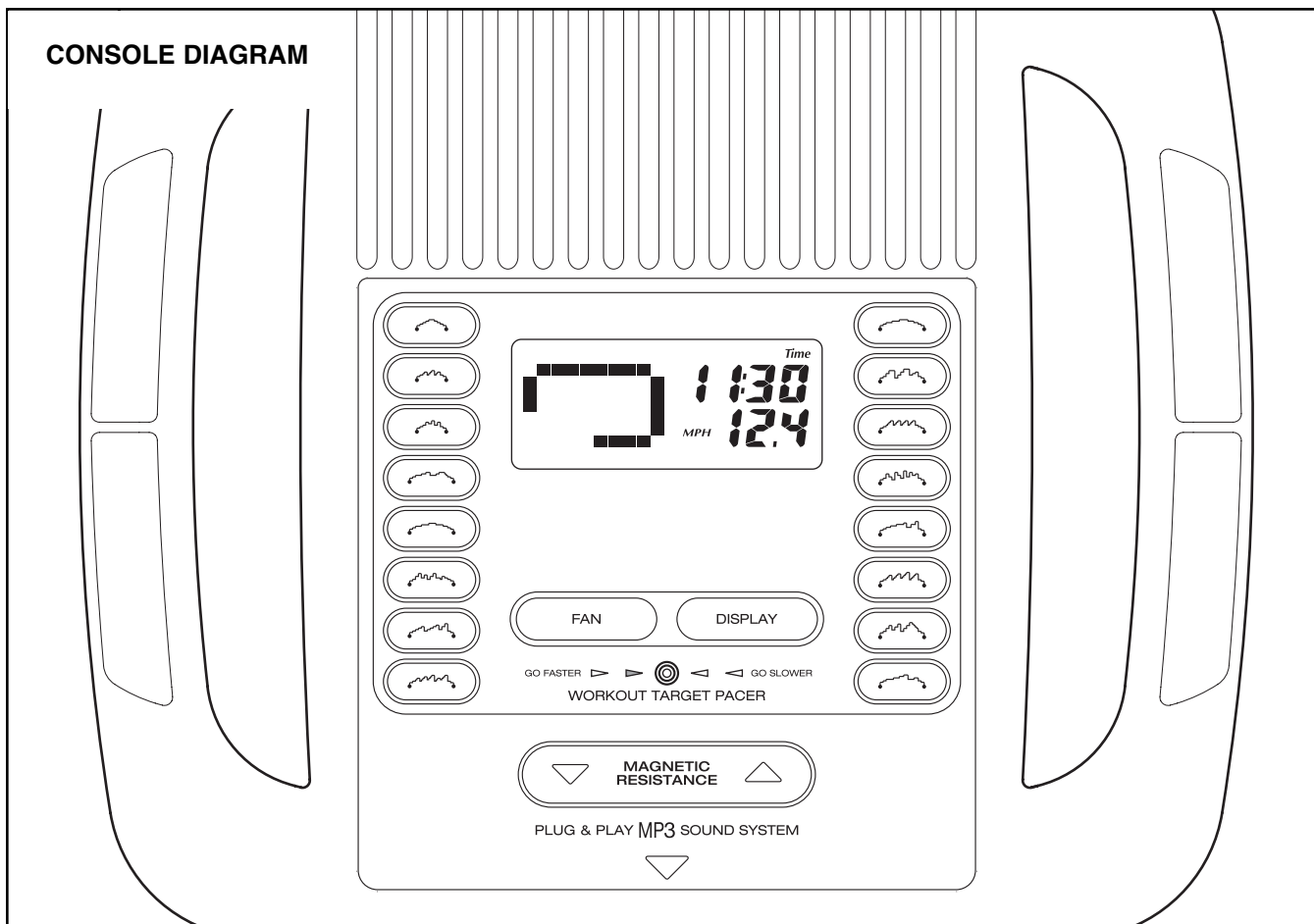

## FEATURES OF THE CONSOLE

The advanced console offers an array of features designed to make your workouts more effective and enjoyable. When you select the manual mode of the console, you can change the resistance of the pedals with the touch of a button. As you exercise, the console will provide continuous exercise feedback. You can even measure your heart rate using the handgrip pulse sensor.

The console also offers sixteen preset workouts. Each workout automatically changes the resistance of the pedals and prompts you to increase or decrease your pedaling speed as it guides you through an effective workout.

You can even connect your MP3 player or CD player to the console's stereo sound system and listen to your favorite music or audio books while you exercise.

**To use the manual mode of the console**, follow the steps beginning on page 12. **To use a preset workout**, see page 14. **To use the stereo sound system**, see page 14.

Note: If there is a sheet of clear plastic on the face of the console, remove the plastic.

## HOW TO USE THE MANUAL MODE

1. **Press any button on the console or begin pedaling to turn on the console.**

When you turn on the console, the displays and the workout target pacer will light. A tone will then sound and the console will be ready for use.

2. **Select the manual mode.**

When you turn on the console, the manual mode will be selected. If you have selected a workout, reselect the manual mode by pressing one of the eight buttons on the right or left side of the console repeatedly until a track appears in the left display.

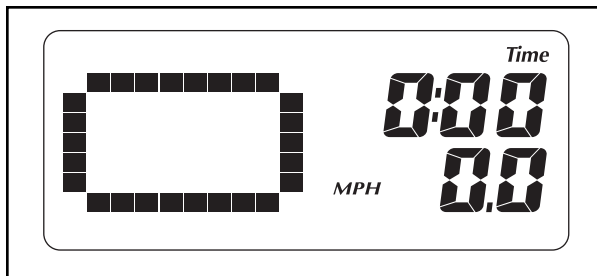

3. **Begin pedaling and change the resistance of the pedals as desired.**

As you pedal, change the resistance of the pedals by pressing the Magnetic Resistance increase and decrease buttons.

There are ten resistance levels. Note: After you press the buttons, it may take a moment for the pedals to reach the selected resistance level.



4. **Follow your progress with the displays.**

The upper right display can show the elapsed time, the approximate number of calories you have burned, and the distance you have pedaled. The display will change modes every few seconds.



The lower right display can show your pedaling speed and the resistance level of the pedals. The display will change modes every few seconds. The display will also show your heart rate when you use the handgrip pulse sensor (see step 5 on page 13).

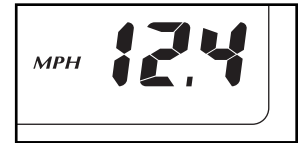

The left display will show a track representing 1/4 mile. As you exercise, indicators will appear in succession around the track until the entire track appears. The track will then disappear and the indicators will again begin to appear in succession.

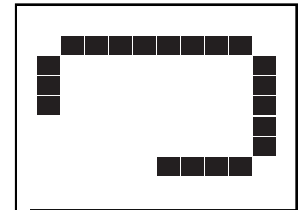

To change the display mode, press the Display button repeatedly until the desired exercise information appears in the upper or lower right display. After several seconds, the displays will change modes automatically as before.

Note: The console can display speed and distance in either miles or kilometers. The letters MPH or Km/H will appear while your pedaling speed is displayed to show which unit of measurement is selected. To change the unit of measurement, first press the Display button for a few seconds until the display is blank; then, release the Display button. Press the Fan button repeatedly to change the unit of measurement. You can also adjust the volume of the console tones at this time. Press the Magnetic Resistance increase and decrease buttons to select a volume level between 1 and 5. When you have selected the desired unit of measurement and volume level, press the Display button again.

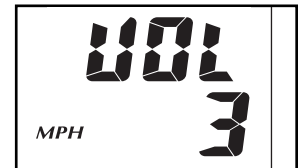

## 5. Measure your heart rate if desired.

**If there are sheets of clear plastic on the metal contacts on the handgrip pulse sensor, remove the plastic. In addition, make sure that your hands are clean. To measure your heart rate, hold the handgrip pulse sensor with your palms resting against the metal contacts. **Avoid moving your hands or gripping the contacts tightly.****

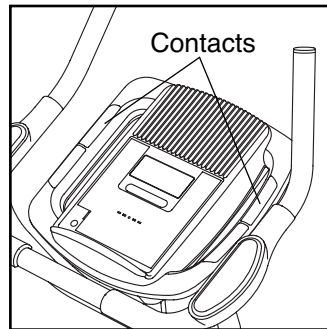

When your pulse is detected, a heart-shaped symbol will flash in the lower right display each time your heart beats, one or two dashes will appear, and then your heart rate will be shown. For the most accurate heart rate reading, hold the contacts for at least 15 seconds.

If your heart rate is not shown, make sure that your hands are positioned as described. Be careful not to move your hands excessively or to squeeze the metal contacts tightly. For optimal performance, clean the metal contacts using a soft cloth; **never use alcohol, abrasives, or chemicals to clean the contacts.**

## 6. Turn on the fan if desired.

To turn on the fan at high speed, press the Fan button. To turn on the fan at low speed, press the Fan button a second time. To select the auto mode, press the Fan button a third time; while the auto mode is selected, the speed of the fan will automatically increase or decrease as you increase or decrease your pedaling speed.

Pivot the thumb tab on the right side of the fan to adjust the fan angle.

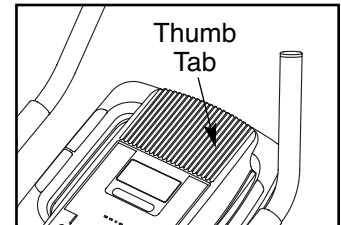

To turn off the fan, press the Fan button again. Note: If the pedals do not move for about thirty seconds, the fan will automatically turn off to conserve the batteries.

## 7. When you are finished exercising, the console will turn off automatically.

If the pedals do not move for several seconds, a series of tones will sound and the console will pause.

If the pedals do not move for about five minutes, the console will turn off and the displays will be reset.

## HOW TO USE A PRESET WORKOUT

1. **Press any button on the console or begin pedaling to turn on the console.**

See step 1 on page 12.

2. **Select a preset workout.**

To select one of the sixteen preset workouts, press one of the eight buttons on the right or left side of the console.

When you select a preset workout, the name of the workout and the maximum resistance level will appear in the display for a few seconds. A profile of the resistance levels of the workout will also scroll across the left side of the display.

3. **Begin pedaling to start the workout.**

Each workout is divided into either 20 or 30 one-minute segments. One resistance level and one target pace setting are programmed for each segment. Note: The same resistance level and/or target pace setting may be programmed for consecutive segments.

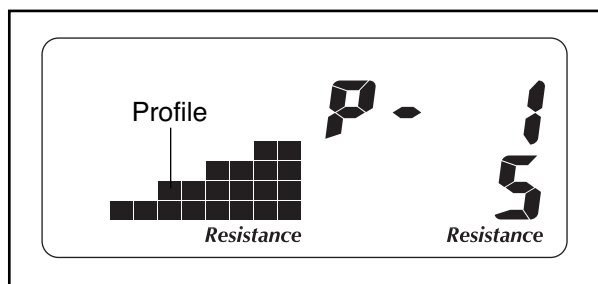

During the workout, the workout profile will show your progress (see the drawing above). The flashing segment of the profile represents the current segment of the workout. The height of the flashing segment indicates the resistance level for the current segment. At the end of each segment of the workout, a series of tones will sound and the next segment of the profile will begin to flash. If a different resistance level is programmed for the next segment, the resistance level will appear in the display for a few seconds to alert you. The resistance of the pedals will then change.

During the workout, the workout target pacer will prompt you to keep your pedaling speed near the target pace setting for the current segment. When a left indicator lights, increase your speed; when a right indicator lights, decrease your speed. When

the center indicator lights, maintain your current speed. **IMPORTANT: The workout target pacer is intended only to provide a goal. Make sure to pedal at a speed that is comfortable for you.**



If the resistance level for the current segment is too high or too low, you can manually override the resistance level by pressing the Magnetic Resistance increase or decrease button. However, when the current segment ends, the resistance of the pedals will automatically adjust to the resistance level programmed for the next segment.

If you stop pedaling for several seconds, a series of tones will sound and the workout will pause. To restart the workout, simply resume pedaling. The workout will continue until the last segment of the workout ends.

4. **Follow your progress with the displays.**

See step 4 on page 12.

5. **Measure your heart rate if desired.**

See step 5 on page 13.

6. **Turn on the fan if desired.**

See step 6 on page 13.

7. **When you are finished exercising, the console will turn off automatically.**

See step 7 on page 13.

## HOW TO USE THE STEREO SOUND SYSTEM

To play music or audio books through the console's stereo sound system while you exercise, plug an audio cable (not included) into the jack on the console and into a jack on your MP3 player or CD player; **make sure that the audio cable is fully plugged in.**

Next, press the play button on your MP3 player or CD player. Adjust the volume of the speakers using the volume control on your MP3 player or CD player.

---

# MAINTENANCE AND TROUBLESHOOTING

Inspect and properly tighten all parts of the exercise cycle regularly. Replace any worn parts immediately.

To clean the exercise cycle, use a damp cloth and a small amount of mild soap—**never use alcohol, abrasives, or chemicals to clean the exercise cycle.**

**IMPORTANT: To avoid damage to the console, keep liquids away from the console and keep the console out of direct sunlight.**

## BATTERY REPLACEMENT

If the console display becomes dim, the batteries should be replaced; most console problems are the result of low batteries. To replace the batteries, see assembly step 8 on page 8.

## PULSE SENSOR TROUBLESHOOTING

For optimal performance of the pulse sensor, keep the metal contacts clean. Clean the contacts with a soft cloth—**never use alcohol, abrasives, or chemicals to clean the metal contacts.**

Avoid moving your hands or squeezing the metal contacts too tightly while using the pulse sensor; doing so may interfere with heart rate readings. For the most accurate heart rate reading, hold the metal contacts for about 15 seconds.

# EXERCISE GUIDELINES

**⚠ WARNING:** Before beginning this or any exercise program, consult your physician. This is especially important for persons over the age of 35 or persons with pre-existing health problems.

The pulse sensor is not a medical device. Various factors may affect the accuracy of heart rate readings. The pulse sensor is intended only as an exercise aid in determining heart rate trends in general.

These guidelines will help you to plan your exercise program. For detailed exercise information, obtain a reputable book or consult your physician. Remember, proper nutrition and adequate rest are essential for successful results.

## EXERCISE INTENSITY

Whether your goal is to burn fat or to strengthen your cardiovascular system, exercising at the proper intensity is the key to achieving results. You can use your heart rate as a guide to find the proper intensity level. The chart below shows recommended heart rates for fat burning and aerobic exercise.

165	155	145	140	130	125	115	♥
145	138	130	125	118	110	103	♥
125	120	115	110	105	95	90	♥
<hr/>							
20	30	40	50	60	70	80	

To find the proper intensity level, find your age at the bottom of the chart (ages are rounded off to the nearest ten years). The three numbers listed above your age define your “training zone.” The lowest number is the heart rate for fat burning, the middle number is the heart rate for maximum fat burning, and the highest number is the heart rate for aerobic exercise.

**Burning Fat**—To burn fat effectively, you must exercise at a low intensity level for a sustained period of time. During the first few minutes of exercise, your body uses *carbohydrate calories* for energy. Only after the first few minutes of exercise does your body begin to use stored *fat calories* for energy. If your goal is to burn fat, adjust the intensity of your exercise until your heart rate is near the lowest number in your training zone. For maximum fat burning, exercise with your heart rate near the middle number in your training zone.

**Aerobic Exercise**—If your goal is to strengthen your cardiovascular system, you must perform aerobic exercise, which is activity that requires large amounts of oxygen for prolonged periods of time. For aerobic exercise, adjust the intensity of your exercise until your heart rate is near the highest number in your training zone.

## WORKOUT GUIDELINES

**Warming up**—Start with 5 to 10 minutes of stretching and light exercise. A warm-up increases your body temperature, heart rate, and circulation in preparation for exercise.

**Training Zone Exercise**—Exercise for 20 to 30 minutes with your heart rate in your training zone. (During the first few weeks of your exercise program, do not keep your heart rate in your training zone for longer than 20 minutes.) Breathe regularly and deeply as you exercise—never hold your breath.

**Cooling down**—Finish with 5 to 10 minutes of stretching. Stretching increases the flexibility of your muscles and helps to prevent post-exercise problems.

## EXERCISE FREQUENCY

To maintain or improve your condition, complete three workouts each week, with at least one day of rest between workouts. After a few months of regular exercise, you may complete up to five workouts each week, if desired. Remember, the key to success is to make exercise a regular and enjoyable part of your everyday life.



## SUGGESTED STRETCHES

The correct form for several basic stretches is shown at the right. Move slowly as you stretch—never bounce.

### 1. Toe Touch Stretch

Stand with your knees bent slightly and slowly bend forward from your hips. Allow your back and shoulders to relax as you reach down toward your toes as far as possible. Hold for 15 counts, then relax. Repeat 3 times. Stretches: Hamstrings, back of knees and back.

### 2. Hamstring Stretch

Sit with one leg extended. Bring the sole of the opposite foot toward you and rest it against the inner thigh of your extended leg. Reach toward your toes as far as possible. Hold for 15 counts, then relax. Repeat 3 times for each leg. Stretches: Hamstrings, lower back and groin.

### 3. Calf/Achilles Stretch

With one leg in front of the other, reach forward and place your hands against a wall. Keep your back leg straight and your back foot flat on the floor. Bend your front leg, lean forward and move your hips toward the wall. Hold for 15 counts, then relax. Repeat 3 times for each leg. To cause further stretching of the achilles tendons, bend your back leg as well. Stretches: Calves, achilles tendons and ankles.

### 4. Quadriceps Stretch

With one hand against a wall for balance, reach back and grasp one foot with your other hand. Bring your heel as close to your buttocks as possible. Hold for 15 counts, then relax. Repeat 3 times for each leg. Stretches: Quadriceps and hip muscles.

### 5. Inner Thigh Stretch

Sit with the soles of your feet together and your knees outward. Pull your feet toward your groin area as far as possible. Hold for 15 counts, then relax. Repeat 3 times. Stretches: Quadriceps and hip muscles.

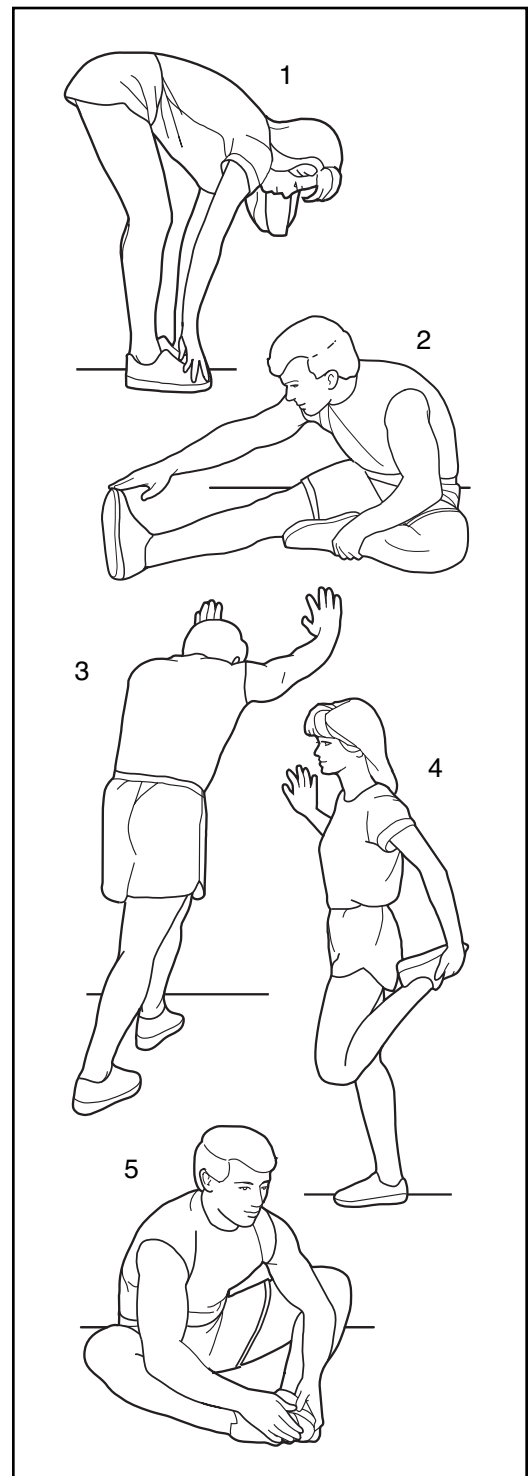

# PART LIST—Model No. RBEX71507.0

R0707A

Key No.	Qty.	Description	Key No.	Qty.	Description
1	1	Frame	30	2	Eye Bolt
2	1	Front Stabilizer	31	1	Lower Wire Harness
3	1	Upright	32	1	Upper Wire Harness
4	4	Endcap	33	6	M10 x 73mm Button Bolt
5	1	Seat Post	34	4	M10 Black Split Washer
6	1	Console	35	3	M10 x 20mm Button Screw
7	1	Eddy Mechanism	36	4	M8 Split Washer
8	1	Resistance Motor	37	5	M8 Nylon Locknut
9	5	M5 x 12mm Screw	38	2	“U” Bracket
10	1	Resistance Cable	39	11	M4 x 25mm Screw
11	1	Seat Knob	40	4	M4 x 15mm Screw
12	1	Seat	41	8	M5 x 20mm Screw
13	1	Pulley/Crank	42	2	M6 Nut
14	1	Rear Stabilizer	43	2	3/8" Nut
15	2	M4 x 15mm Screw	44	2	Flywheel Nut
16	1	Magnet	45	1	M8 x 20mm Bolt
17	1	Left Side Shield	46	1	M8 Washer
18	1	Right Side Shield	47	1	Handlebar
19	1	Spring	48	1	Handlebar Bracket
20	1	Seat Post Bushing	49	1	Left Arm Pad
21	1	Reed Switch/Wire	50	1	Right Arm Pad
22	1	Clamp	51	2	Handlebar Endcap
23	1	Belt	52	2	M10 Nylon Locknut
24	1	Left Pedal	53	4	M6 x 40mm Button Bolt
25	2	Pedal Strap	54	4	M6 Nylon Locknut
26	1	Right Pedal	55	3	M10 Bright Split Washer
27	1	Crank Bearing Set	*	—	User's Manual
28	1	Idler	*	—	Hex Key
29	1	Water Bottle Holder	*	—	Assembly Tool

Note: Specifications are subject to change without notice. See the back cover of this manual for information about ordering replacement parts. \*These parts are not illustrated.

# EXPLODED DRAWING—Model No. RBEX71507.0

R0707A

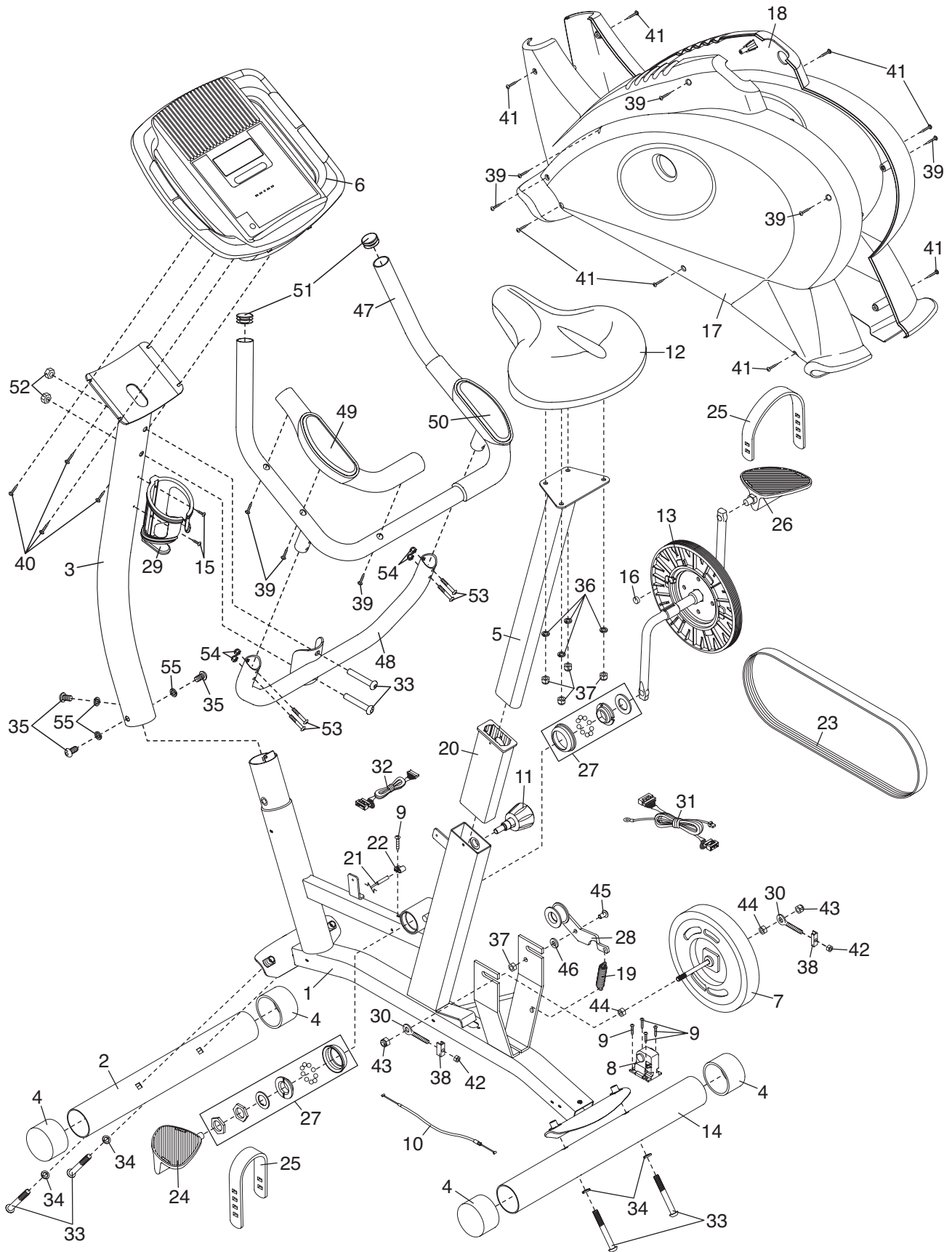

---

# ORDERING REPLACEMENT PARTS

To order replacement parts, please see the front cover of this manual. To help us assist you, be prepared to provide the following information when contacting us:

- the model number and serial number of the product (see the front cover of this manual)
- the name of the product (see the front cover of this manual)
- the key number and description of the replacement part(s) (see the PART LIST and the EXPLODED DRAWING near the end of this manual)

## LIMITED WARRANTY

ICON Health & Fitness, Inc. (ICON) warrants this product to be free from defects in workmanship and material, under normal use and service conditions, for a period of ninety (90) days from the date of purchase. This warranty extends only to the original purchaser. ICON's obligation under this warranty is limited to replacing or repairing, at ICON's option, the product through one of its authorized service centers. All repairs for which warranty claims are made must be pre-authorized by ICON. This warranty does not extend to any product or damage to a product caused by or attributable to freight damage, abuse, misuse, improper or abnormal usage or repairs not provided by an ICON authorized service center, products used for commercial or rental purposes, or products used as store display models. No other warranty beyond that specifically set forth above is authorized by ICON.

ICON is not responsible or liable for indirect, special or consequential damages arising out of or in connection with the use or performance of the product or damages with respect to any economic loss, loss of property, loss of revenues or profits, loss of enjoyment or use, costs of removal, installation or other consequential damages of whatsoever nature. Some states do not allow the exclusion or limitation of incidental or consequential damages. Accordingly, the above limitation may not apply to you.

The warranty extended hereunder is in lieu of any and all other warranties and any implied warranties of merchantability or fitness for a particular purpose is limited in its scope and duration to the terms set forth herein. Some states do not allow limitations on how long an implied warranty lasts. Accordingly, the above limitation may not apply to you.

This warranty gives you specific legal rights. You may also have other rights which vary from state to state.

**ICON HEALTH & FITNESS, INC., 1500 S. 1000 W., LOGAN, UT 84321-9813**