

OPERATOR'S MANUAL

**6-1/2 in. CIRCULAR SAW
DOUBLE INSULATED
R3203-1**

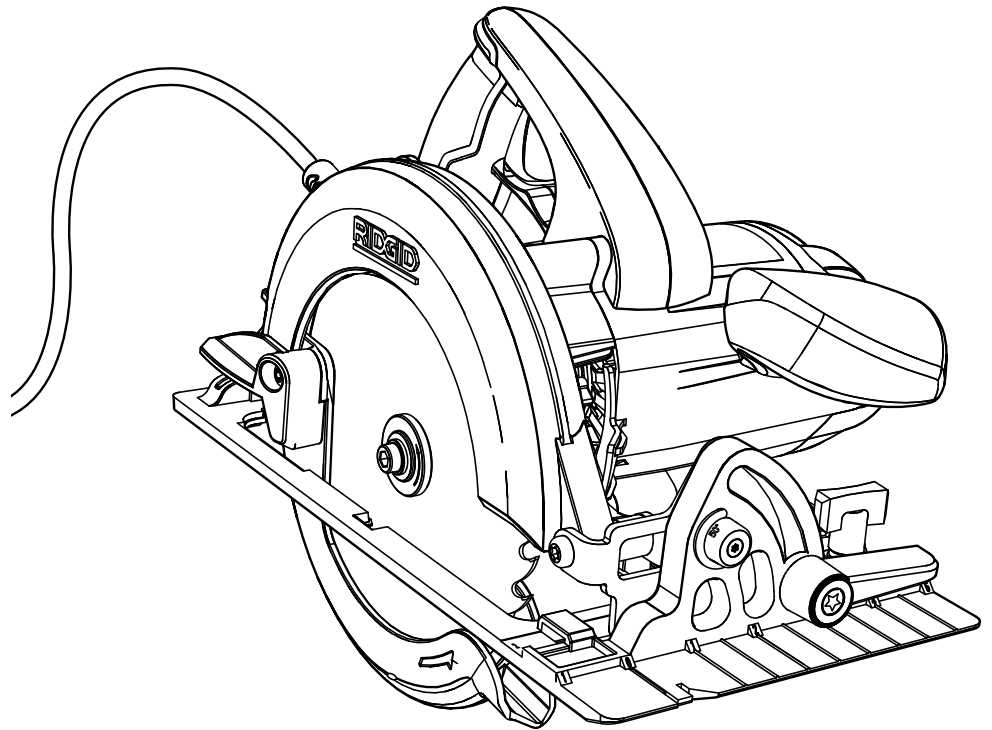

Your circular saw has been engineered and manufactured to our high standards for dependability, ease of operation, and operator safety. When properly cared for, it will give you years of rugged, trouble-free performance.

⚠ WARNING:

To reduce the risk of injury, the user must read and understand the operator's manual before using this product.

Thank you for buying a RIDGID product.

SAVE THIS MANUAL FOR FUTURE REFERENCE

TABLE OF CONTENTS

■ Introduction	2
■ General Safety Rules.....	3-4
■ Specific Safety Rules.....	4-5
■ Symbols.....	6-7
■ Electrical	8
■ Features.....	9-10
■ Assembly.....	11-12
■ Operation.....	13-20
■ Adjustments.....	20-21
■ Maintenance.....	21-22
■ Accessories	22
■ Warranty	23
■ Customer Service Information.....	24

INTRODUCTION

This tool has many features for making its use more pleasant and enjoyable. Safety, performance, and dependability have been given top priority in the design of this product making it easy to maintain and operate.

GENERAL SAFETY RULES

WARNING!

Read all instructions. Failure to follow all instructions listed below may result in electric shock, fire and/or serious injury. The term “power tool” in all of the warnings listed below refers to your mains-operated (corded) power tool or battery-operated (cordless) power tool.

SAVE THESE INSTRUCTIONS

WORK AREA SAFETY

- **Keep work area clean and well lit.** Cluttered or dark areas invite accidents.
- **Do not operate power tools in explosive atmospheres, such as in the presence of flammable liquids, gases or dust.** Power tools create sparks which may ignite the dust or fumes.
- **Keep children and bystanders away while operating a power tool.** Distractions can cause you to lose control.

ELECTRICAL SAFETY

- **Power tool plugs must match the outlet. Never modify the plug in any way. Do not use any adapter plugs with earthed (grounded) power tools.** Unmodified plugs and matching outlets will reduce risk of electric shock.
- **Avoid body contact with earthed or grounded surfaces such as pipes, radiators, ranges and refrigerators.** There is an increased risk of electric shock if your body is earthed or grounded.
- **Do not expose power tools to rain or wet conditions.** Water entering a power tool will increase the risk of electric shock.
- **Do not abuse the cord. Never use the cord for carrying, pulling or unplugging the power tool. Keep cord away from heat, oil, sharp edges or moving parts.** Damaged or entangled cords increase the risk of electric shock.
- **When operating a power tool outdoors, use an extension cord suitable for outdoor use.** Use of a cord suitable for outdoor use reduces the risk of electric shock.

PERSONAL SAFETY

- **Stay alert, watch what you are doing and use common sense when operating a power tool. Do not use a power tool while you are tired or under the influence of drugs, alcohol or medication.** A moment of inattention while operating power tools may result in serious personal injury.
- **Use safety equipment. Always wear eye protection.** Safety equipment such as dust mask, non-skid safety shoes, hard hat, or hearing protection used for appropriate conditions will reduce personal injuries.
- **Avoid accidental starting. Ensure the switch is in the off-position before plugging in.** Carrying power tools with your finger on the switch or plugging in power tools that have the switch on invites accidents.

- **Remove any adjusting key or wrench before turning the power tool on.** A wrench or a key left attached to a rotating part of the power tool may result in personal injury.
- **Do not overreach. Keep proper footing and balance at all times.** This enables better control of the power tool in unexpected situations.
- **Dress properly. Do not wear loose clothing or jewelry. Keep your hair, clothing and gloves away from moving parts.** Loose clothes, jewelry or long hair can be caught in moving parts.
- **If devices are provided for the connection of dust extraction and collection facilities, ensure these are connected and properly used.** Use of these devices can reduce dust-related hazards.
- **Do not wear loose clothing or jewelry. Contain long hair.** Loose clothes, jewelry, or long hair can be drawn into air vents.
- **Do not use on a ladder or unstable support.** Stable footing on a solid surface enables better control of the power tool in unexpected situations.

POWER TOOL USE AND CARE

- **Do not force the power tool. Use the correct power tool for your application.** The correct power tool will do the job better and safer at the rate for which it was designed.
- **Do not use the power tool if the switch does not turn it on and off.** Any power tool that cannot be controlled with the switch is dangerous and must be repaired.
- **Disconnect the plug from the power source and/or the battery pack from the power tool before making any adjustments, changing accessories, or storing power tools.** Such preventive safety measures reduce the risk of starting the power tool accidentally.
- **Store idle power tools out of the reach of children and do not allow persons unfamiliar with the power tool or these instructions to operate the power tool.** Power tools are dangerous in the hands of untrained users.
- **Maintain power tools. Check for misalignment or binding of moving parts, breakage of parts and any other condition that may affect the power tool's operation. If damaged, have the power tool repaired before use.** Many accidents are caused by poorly maintained power tools.
- **Keep cutting tools sharp and clean.** Properly maintained cutting tools with sharp cutting edges are less likely to bind and are easier to control.
- **Use the power tool, accessories and tool bits etc., in accordance with these instructions and in the manner intended for the particular type of power tool, taking into account the working conditions and the work to be performed.** Use of the power tool for operations different from those intended could result in a hazardous situation.

GENERAL SAFETY RULES

SERVICE

- **Have your power tool serviced by a qualified repair person using only identical replacement parts.** This will ensure that the safety of the power tool is maintained.

WARNING!

To reduce the risk of injury, user must read instruction manual.

- **When servicing a power tool, use only identical replacement parts. Follow instructions in the Maintenance section of this manual.** Use of unauthorized parts or failure to follow Maintenance instructions may create a risk of shock or injury.

SPECIFIC SAFETY RULES

- **DANGER! Keep hands away from cutting area and the blade. Keep your second hand on auxiliary handle or motor housing.** If both hands are holding the saw, they cannot be cut by the blade.
- **Do not reach underneath the workpiece.** The guard cannot protect you from the blade below the workpiece.
- **Adjust the cutting depth to the thickness of the workpiece.** Less than a full tooth of the blade teeth should be visible below the workpiece.
- **Never hold piece being cut in your hands or across your leg. Secure the workpiece to a stable platform.** It is important to support the work properly to minimize body exposure, blade binding, or loss of control.
- **Hold power tool by insulated gripping surfaces when performing an operation where the cutting tool may contact hidden wiring or its own cord.** Contact with a “live” wire will also make exposed metal parts of the power tool “live” and shock the operator.
- **When ripping, always use a rip fence or straight edge guide.** This improves the accuracy of cut and reduces the chance of blade binding.
- **Always use blades with correct size and shape (diamond versus round) of arbor holes.** Blades that do not match the mounting hardware of the saw will run eccentrically, causing loss of control.
- **Never use damaged or incorrect blade washers or bolt.** The blade washers and bolt were specially designed for your saw for optimum performance and safety of operation.

CAUSES AND OPERATOR PREVENTION OF KICKBACK:

Kickback is a sudden reaction to a pinched, bound, or misaligned saw blade, causing an uncontrolled saw to lift up and out of the workpiece toward the operator.

When the blade is pinched or bound tightly by the kerf closing down, the blade stalls and the motor reaction drives the unit rapidly back toward the operator.

If the blade becomes twisted or misaligned in the cut, the teeth at the back edge of the blade can dig into the top surface of the wood causing the blade to climb out of the kerf and jump back toward the operator.

Kickback is the result of saw misuse and/or incorrect operating procedures or conditions and can be avoided by taking proper precautions, as given below:

- **Maintain a firm grip with both hands on the saw and position your arms to resist kickback forces. Position your body to either side of the blade, but not in line with the blade.** Kickback could cause the saw to jump backwards, but kickback forces can be controlled by the operator, if proper precautions are taken.
- **When blade is binding, or when interrupting a cut for any reason, release the trigger and hold the saw motionless in the material until the blade comes to a complete stop. Never attempt to remove the saw from the work or pull the saw backward while the blade is in motion, or kickback may occur.** Investigate and take corrective actions to eliminate the cause of blade binding.
- **When restarting a saw in the workpiece, center the saw blade in the kerf and check that saw teeth are not engaged into the material.** If saw blade is binding, it may walk up or kickback from the workpiece as the saw is restarted.
- **Support large panels to minimize the risk of blade pinching and kickback.** Large panels tend to sag under their own weight. Supports must be placed under the panel on both sides, near the line of cut and near the edge of the panel.
- **Do not use dull or damaged blades.** Unsharpened or improperly set blades produce narrow kerf causing excessive friction, blade binding and kickback.
- **Blade depth and bevel adjusting locking levers must be tight and secure before making cut.** If blade adjustment shifts while cutting, it may cause binding and kickback.
- **Use extra caution when making a “Plunge Cut” into existing walls or other blind areas.** The protruding blade may cut objects that can cause kickback.
- **Check lower guard for proper closing before each use. Do not operate saw if lower guard does not move freely and close instantly. Never clamp or tie the lower guard into the open position.** If saw is accidentally dropped, lower guard may be bent. Raise the lower guard with the retracting handle. Make sure it moves freely and does not touch the blade or any other part, in all angles and depths of cut.

SPECIFIC SAFETY RULES

- **Check the operation of the lower guard spring. If the guard and the spring are not operating properly, they must be serviced before use.** Lower guard may operate sluggishly due to damaged parts, gummy deposits, or a buildup of debris.
- **Lower guard should be retracted manually only for special cuts, such as “Plunge Cuts” and “Compound Cuts.” Raise lower guard by retracting handle. As soon as blade enters the material, the lower guard must be released.** For all other sawing, the lower guard should operate automatically.
- **Always observe that the lower guard is covering the blade before placing saw down on bench or floor.** An unprotected, coasting blade will cause the saw to walk backwards, cutting whatever is in its path. Be aware of the time it takes for the blade to stop after switch is released.
- **Know your power tool. Read operator’s manual carefully. Learn its applications and limitations, as well as the specific potential hazards related to this tool.** Following this rule will reduce the risk of electric shock, fire, or serious injury.
- **Always wear safety glasses. Everyday eyeglasses have only impact-resistant lenses; they are NOT safety glasses.** Following this rule will reduce the risk of serious personal injury.
- **Protect your lungs. Wear a face or dust mask if the operation is dusty.** Following this rule will reduce the risk of serious personal injury.
- **Protect your hearing. Wear hearing protection during extended periods of operation.** Following this rule will reduce the risk of serious personal injury.
- **Inspect tool cords periodically and, if damaged, have repaired at your nearest authorized service center. Constantly stay aware of cord location.** Following this rule will reduce the risk of electric shock or fire.
- **Check damaged parts. Before further use of the tool, a guard or other part that is damaged should be carefully checked to determine that it will operate properly and perform its intended function. Check for alignment of moving parts, binding of moving parts, breakage of parts, mounting, and any other conditions that may affect its operation. A guard or other part that is damaged should be properly repaired or replaced by an authorized service center.** Following this rule will reduce the risk of shock, fire, or serious injury.
- **Make sure your extension cord is in good condition. When using an extension cord, be sure to use one heavy enough to carry the current your product will draw. A wire gage size (A.W.G.) of at least 14 is recommended for an extension cord 50 feet or less in length. A cord exceeding 100 feet is not recommended. If in doubt, use the next heavier gage. The smaller the gage number, the heavier the cord. An undersized cord will cause a drop in line voltage resulting in loss of power and overheating.**
- **Inspect for and remove all nails from lumber before using this tool.** Following this rule will reduce the risk of serious personal injury.
- **If the power supply cord is damaged, it must be replaced only by the manufacturer or by an authorized service center to avoid risk.**
- **Save these instructions.** Refer to them frequently and use them to instruct others who may use this tool. If you loan someone this tool, loan them these instructions also.

WARNING:











Some dust created by power sanding, sawing, grinding, drilling, and other construction activities contains chemicals known to cause cancer, birth defects or other reproductive harm. Some examples of these chemicals are:

- lead from lead-based paints,
- crystalline silica from bricks and cement and other masonry products, and
- arsenic and chromium from chemically-treated lumber.

Your risk from these exposures varies, depending on how often you do this type of work. To reduce your exposure to these chemicals: work in a well ventilated area, and work with approved safety equipment, such as those dust masks that are specially designed to filter out microscopic particles.



SYMBOLS

Some of the following symbols may be used on this tool. Please study them and learn their meaning. Proper interpretation of these symbols will allow you to operate the tool better and safer.

SYMBOL	NAME	DESIGNATION/EXPLANATION
V	Volts	Voltage
A	Amperes	Current
Hz	Hertz	Frequency (cycles per second)
W	Watt	Power
min	Minutes	Time
~	Alternating Current	Type of current
≡	Direct Current	Type or a characteristic of current
n_0	No Load Speed	Rotational speed, at no load
	Class II Tool	Double-insulated construction
.../min	Per Minute	Revolutions, strokes, surface speed, orbits etc., per minute
	Wet Conditions Alert	Do not expose to rain or use in damp locations.
	Read The Operator's Manual	To reduce the risk of injury, user must read and understand operator's manual before using this product.
	Eye Protection	Always wear safety goggles or safety glasses with side shields and, as necessary, a full face shield when operating this product.
	Safety Alert	Precautions that involve your safety.
	No Hands Symbol	Failure to keep your hands away from the blade will result in serious personal injury.
	No Hands Symbol	Failure to keep your hands away from the blade will result in serious personal injury.
	No Hands Symbol	Failure to keep your hands away from the blade will result in serious personal injury.
	No Hands Symbol	Failure to keep your hands away from the blade will result in serious personal injury.
	Hot Surface	To reduce the risk of injury or damage, avoid contact with any hot surface.

SYMBOLS

The following signal words and meanings are intended to explain the levels of risk associated with this product.

SYMBOL	SIGNAL	MEANING
	DANGER:	Indicates an imminently hazardous situation, which, if not avoided, will result in death or serious injury.
	WARNING:	Indicates a potentially hazardous situation, which, if not avoided, could result in death or serious injury.
	CAUTION:	Indicates a potentially hazardous situation, which, if not avoided, may result in minor or moderate injury.
	CAUTION:	(Without Safety Alert Symbol) Indicates a situation that may result in property damage.

SERVICE

Servicing requires extreme care and knowledge and should be performed only by a qualified service technician. For service we suggest you return the product to your nearest **AUTHORIZED SERVICE CENTER** for repair. When servicing, use only identical replacement parts.



WARNING:

To avoid serious personal injury, do not attempt to use this product until you read thoroughly and understand completely the operator's manual. If you do not understand the warnings and instructions in the operator's manual, do not use this product. Call RIDGID customer service for assistance.

WARNING:



The operation of any power tool can result in foreign objects being thrown into your eyes, which can result in severe eye damage. Before beginning power tool operation, always wear safety goggles or safety glasses with side shields and, when needed, a full face shield. We recommend Wide Vision Safety Mask for use over eyeglasses or standard safety glasses with side shields. Always use eye protection which is marked to comply with ANSI Z87.1.

SAVE THESE INSTRUCTIONS

ELECTRICAL

DOUBLE INSULATION

Double insulation is a concept in safety in electric power tools, which eliminates the need for the usual three-wire grounded power cord. All exposed metal parts are isolated from the internal metal motor components with protecting insulation. Double insulated tools do not need to be grounded.

WARNING:

The double insulated system is intended to protect the user from shock resulting from a break in the tool's internal wiring. Observe all normal safety precautions to avoid electrical shock.

NOTE: Servicing of a tool with double insulation requires extreme care and knowledge of the system and should be performed only by a qualified service technician. For service, we suggest you return the tool to your nearest authorized service center for repair. Always use original factory replacement parts when servicing.

ELECTRICAL CONNECTION

This tool has a precision-built electric motor. It should be connected to a **power supply that is 120 volts, 60 Hz, AC only (normal household current)**. Do not operate this tool on direct current (DC). A substantial voltage drop will cause a loss of power and the motor will overheat. If your tool does not operate when plugged into an outlet, double-check the power supply.

EXTENSION CORDS

When using a power tool at a considerable distance from a power source, be sure to use an extension cord that has the capacity to handle the current the tool will draw. An undersized cord will cause a drop in line voltage, resulting in overheating and loss of power. Use the chart to determine the minimum wire size required in an extension cord. Only round jacketed cords listed by Underwriter's Laboratories (UL) should be used.

When working outdoors with a tool, use an extension cord that is designed for outside use. This type of cord is designated with "WA" on the cord's jacket.

Before using any extension cord, inspect it for loose or exposed wires and cut or worn insulation.

**Ampere rating (on tool data plate)

Cord Length	Wire Size (A.W.G.)					
	0-2.0	2.1-3.4	3.5-5.0	5.1-7.0	7.1-12.0	12.1-16.0
25'	16	16	16	16	14	14
50'	16	16	16	14	14	12
100'	16	16	14	12	10	—

**Used on 12 gauge - 20 amp circuit.

NOTE: AWG = American Wire Gauge

WARNING:

Keep the extension cord clear of the working area. Position the cord so that it will not get caught on lumber, tools or other obstructions while you are working with a power tool. Failure to do so can result in serious personal injury.

WARNING:

Check extension cords before each use. If damaged replace immediately. Never use tool with a damaged cord since touching the damaged area could cause electrical shock resulting in serious injury.

FEATURES

PRODUCT SPECIFICATIONS

Blade Diameter.....6-1/2 in.
 Blade Arbor5/8 in.
 Cutting Depth at 90°.....2-1/8 in.
 Cutting Depth at 45°.....1-5/8 in.
 Cutting Depth at 50°.....1-1/2 in.

No Load Speed6,100 r/min. (RPM)
 Input120 V, 60 Hz, AC only, 12 Amps
 Net Weight.....8 lbs.

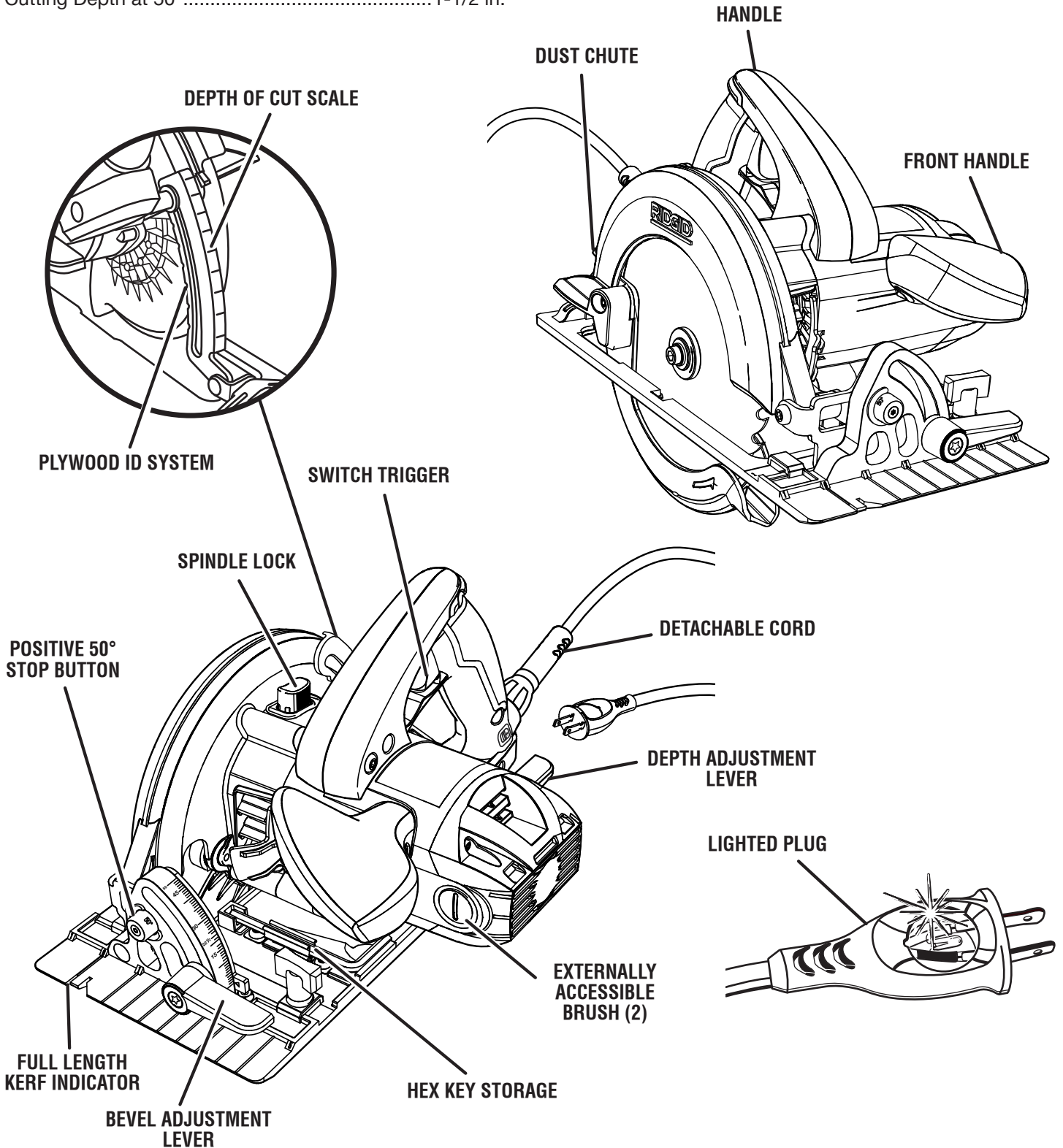

Fig. 1

FEATURES

KNOW YOUR CIRCULAR SAW

See Figure 1.

The safe use of this product requires an understanding of the information on the tool and in this operator's manual as well as a knowledge of the project you are attempting. Before use of this product, familiarize yourself with all operating features and safety rules.

DETACHABLE CORD

The detachable cord can be easily stored or replaced quickly if damaged.

DUST CHUTE

To direct saw dust and chips away from the operator, a dust chute is located on the rear of the upper blade guard.

ERGONOMIC DESIGN

The design provides for easy handling. It is designed for comfort when operating in different positions and at different angles.

EXTERNALLY ACCESSIBLE BRUSHES

Externally accessible brushes extend the life of the machine.

FRONT AND REAR KERF INDICATORS

The front kerf indicator aides in following the line of cut when cutting the workpiece. The rear kerf indicator aids in aligning plunge cuts and following the kerf when exiting the workpiece.

HEX KEY STORAGE

Hex key storage is located on the saw base. The storage area can be accessed by adjusting the saw to a bevel position.

INDEXING LEVERS

The lock levers on the saw can be repositioned to suit user preference.

LIGHTED PLUG

The lighted plug helps to easily identify live tools.

PLYWOOD ID SYSTEM

Quickly identify common plywood thicknesses using the plywood ID system.

SHOCK ABSORBING FRONT HANDLE

The handle is designed for durability and operator comfort.

SPINDLE LOCK

The spindle lock allows you to secure the blade when turning the blade screw for blade changes.

ASSEMBLY

UNPACKING

This product requires assembly.

- Carefully remove the tool and any accessories from the box. Make sure that all items listed in the packing list are included.
- Inspect the tool carefully to make sure no breakage or damage occurred during shipping.
- Do not discard the packing material until you have carefully inspected and satisfactorily operated the tool.
- If any parts are damaged or missing, please call 1-866-539-1710 for assistance.

PACKING LIST

6-1/2 in. Circular Saw
18-tooth Carbide Tipped Blade
Cord Wrap
Hex Key
Tool Bag
Operator's Manual

WARNING:

If any parts are damaged or missing do not operate this tool until the parts are replaced. Failure to heed this warning could result in serious personal injury.

WARNING:

Do not attempt to modify this tool or create accessories not recommended for use with this tool. Any such alteration or modification is misuse and could result in a hazardous condition leading to possible serious personal injury.

WARNING:

Do not connect to power supply until assembly is complete. Failure to comply could result in accidental starting and possible serious personal injury.

WARNING:

A 6-1/2 in. blade is the maximum blade capacity of the saw. Never use a blade that is too thick to allow outer blade washer to engage with the flat on the spindle. Larger blades will come in contact with the blade guards, while thicker blades will prevent blade screw from securing blade on spindle. Either of these situations could result in a serious accident.

ASSEMBLY

CAUTION:

To prevent damage to the spindle or spindle lock, always allow motor to come to a complete stop before engaging spindle lock.

ATTACHING BLADE

See Figures 2 - 3.

- Unplug the saw.
- Depress and hold spindle lock.
- Remove blade screw by turning it counterclockwise with the provided hex key, while keeping the spindle lock depressed.
- Remove outer blade washer ("D" washer).

WARNING:

If inner flange bushing has been removed, replace it before placing blade on spindle. Failure to do so will prevent blade from tightening properly and could result in serious personal injury.

- Retract the lower blade guard into the upper blade guard using the lower blade guard handle. Make sure the lower guard spring works properly, allowing the guard to move freely.
- Check to see that the saw teeth and arrow on the saw blade and the arrow on the lower guard are pointing in the same direction.
NOTE: The saw teeth point upward at the front of the saw as shown.
- Fit the saw blade inside the lower blade guard and onto the spindle.
- Replace "D" washer.
- Depress and hold spindle lock and replace blade screw.
- Tighten blade screw securely by turning it clockwise with the hex key.

NOTE: Never use a blade that is too thick to allow the "D" washer to engage with the flat on the spindle.

REMOVING BLADE

See Figures 2 - 3.

- Unplug the saw.
- Depress spindle lock.
- Remove blade screw by turning it counterclockwise with the provided hex key, while keeping the spindle lock depressed.
- Remove outer blade washer ("D" washer).
- Lift lower blade guard.
- Remove blade.

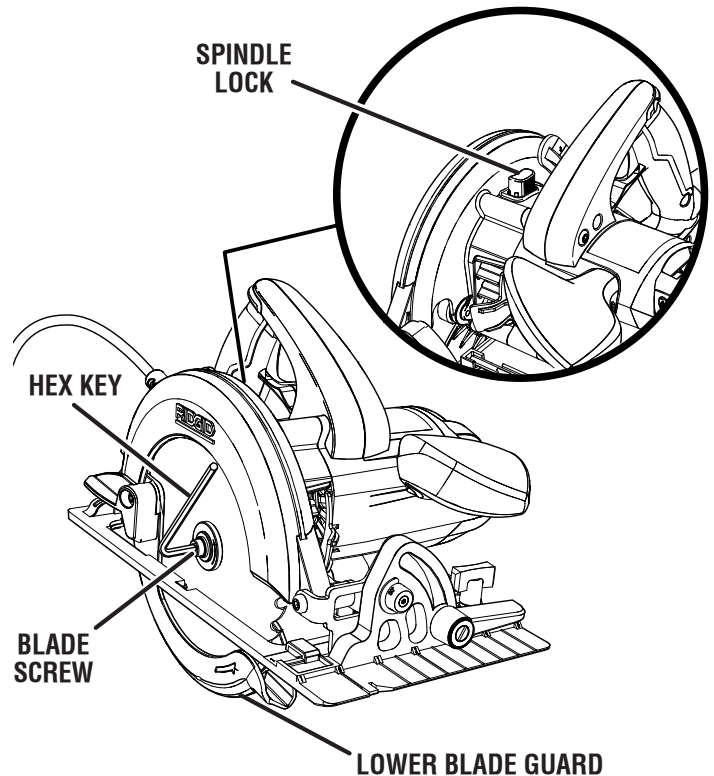

Fig. 2

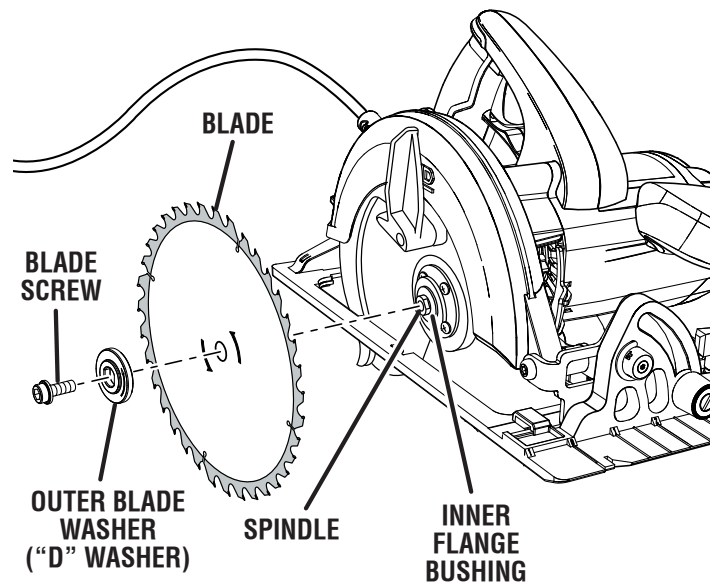

Fig. 3

OPERATION

WARNING:

Do not allow familiarity with tools to make you careless. Remember that a careless fraction of a second is sufficient to inflict serious injury.

WARNING:

Always wear safety goggles or safety glasses with side shields when operating power tools. Failure to do so could result in objects being thrown into your eyes resulting in possible serious injury.

APPLICATIONS

You may use this tool for the purpose listed below:

- Cutting all types of wood and wood products

NOTE: The use of abrasive cut-off wheels is not recommended for this saw.

KICKBACK

See Figures 4 - 7.

Kickback occurs when the blade stalls rapidly and the saw is driven back towards you. Blade stalling is caused by any action which pinches the blade in the wood.

DANGER:

Release switch immediately if blade binds or saw stalls. Kickback could cause you to lose control of the saw. Loss of control can lead to serious personal injury.

To guard against kickback, avoid dangerous practices such as the following:

- Setting blade depth incorrectly
- Sawing into knots or nails in workpiece
- Twisting the blade while making a cut
- Making a cut with a dull, gummed up, or improperly set blade
- Supporting the workpiece incorrectly
- Forcing a cut
- Cutting warped or wet lumber
- Operating the tool incorrectly or misusing the tool

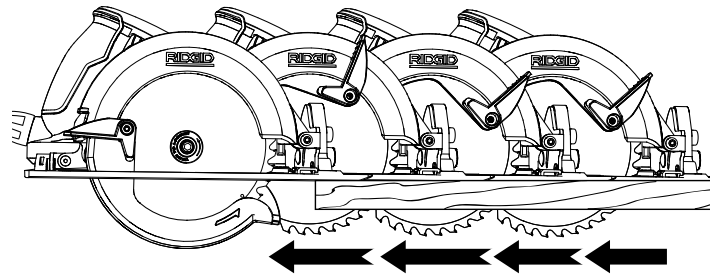

KICKBACK - BLADE SET TOO DEEP

Fig. 4

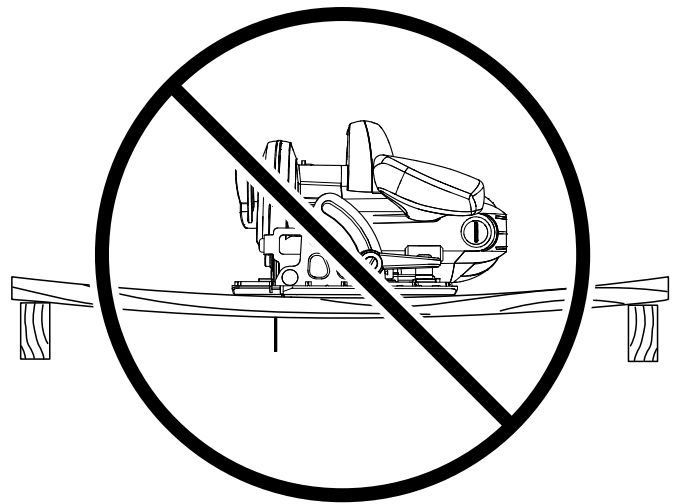

INCORRECT SUPPORT

Fig. 5

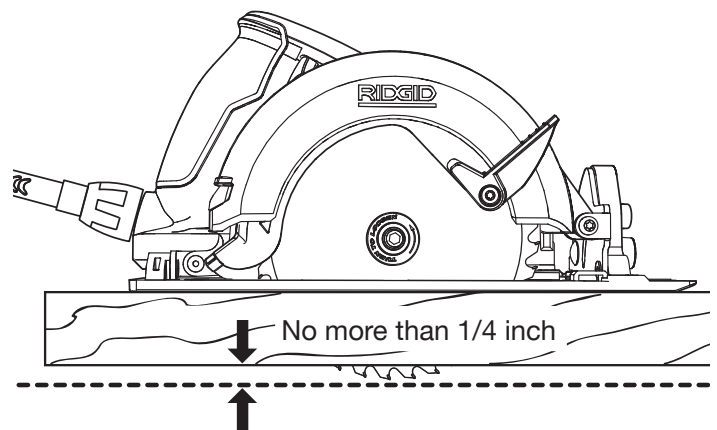

**CORRECT BLADE DEPTH SETTING = BLADE EXPOSED 1/4 in.
OR LESS ON UNDERSIDE OF WORKPIECE**

Fig. 6

OPERATION

To lessen the chance of kickback, follow these safety practices:

- Keep the blade at the correct depth setting. The depth setting should not exceed 1/4 in. below the material being cut.
- Inspect the workpiece for knots or nails before cutting. Never saw into a knot or nail.
- Make straight cuts. Always use a straight edge guide when rip cutting. This helps prevent twisting the blade.
- Use clean, sharp, and properly set blades. Never make cuts with dull blades.
- Support the workpiece properly before beginning a cut.
- Use steady, even pressure when making a cut. Never force a cut.
- Do not cut warped or wet lumber.
- Hold the saw firmly with both hands and keep your body in a balanced position so as to resist the forces if kickback should occur.

WARNING:

When using the saw, always stay alert and exercise control. Do not remove the saw from the workpiece while the blade is moving.

SAW BLADES

The best of saw blades will not cut efficiently if they are not kept clean, sharp, and properly set. Using a dull blade will place a heavy load on the saw and increase the danger of kickback. Keep extra blades on hand so that sharp blades are always available.

Gum and wood pitch hardened on blades will slow the saw down. Remove saw blade from the saw and use gum and pitch remover, hot water, or kerosene to remove these accumulations. **DO NOT USE GASOLINE.**

BLADE GUARD SYSTEM

See Figure 8.

The lower blade guard attached to the circular saw is there for your protection and safety. Do not alter it for any reason. If it becomes damaged, do not operate the saw until you have the guard repaired or replaced. Always leave guard in operating position when using the saw.

DANGER:

When sawing through work, lower blade guard does not cover blade on the underside of work. Since blade is exposed on underside of work, keep hands and fingers away from cutting area. Any part of your body coming in contact with moving blade will result in serious injury.

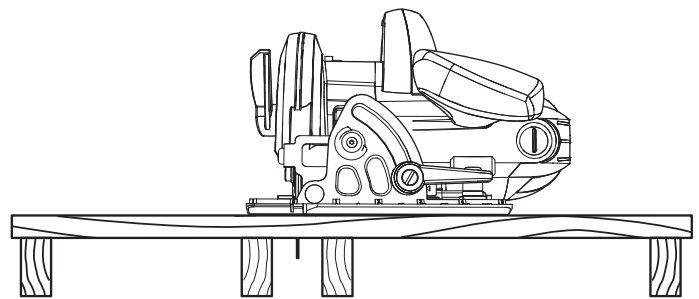

CORRECT SUPPORT

Fig. 7

LOWER BLADE GUARD IS IN UP POSITION WHEN MAKING A CUT

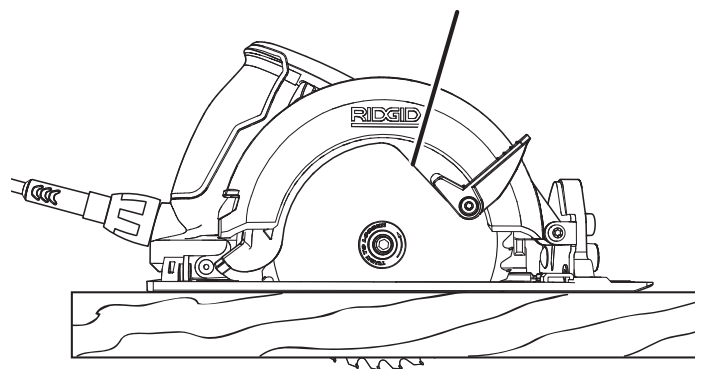

Fig. 8

CAUTION:

To avoid possible serious injury, never use saw when guard is not operating correctly. Check the guard for correct operation before each use. The guard is operating correctly when it moves freely, and instantly returns to the closed position. If you drop the saw, check the lower blade guard and bumper for damage at all depth settings before reuse.

If at any time the lower blade guard does not snap closed, unplug the saw from the power supply. Exercise the lower guard by moving it rapidly back and forth from the full open position to the closed position several times. Normally this will restore the guard to its normal operating condition. If it does not correct a slow or sluggish closing lower guard, do not use the saw. Take it to an authorized factory service center for repair.

OPERATION

DETACHABLE CORD

See figures 9 - 10.

The detachable cord can be easily stored or replaced quickly if damaged.

To detach:

- Push cord lock button forward and hold.
- Twist cord fully counterclockwise and pull away from the saw.

To reattach:

- Align notch in the saw cord receptacle with the ridge in the cord head.
- Insert cord head into cord receptacle and twist fully clockwise.

NOTE: You will hear a click when the cord is securely attached to the saw.

STARTING/STOPPING THE SAW

See Figure 11.

To start the saw: Depress the switch trigger.

Always let the blade reach full speed, then guide the saw into the workpiece.

⚠ WARNING:

The blade coming in contact with the workpiece before it reaches full speed could cause the saw to “kickback” toward you, resulting in serious injury.

To stop the saw: Release the switch trigger.

After you release the switch trigger, allow the blade to come to a complete stop. Do not remove the saw from the workpiece while the blade is moving.

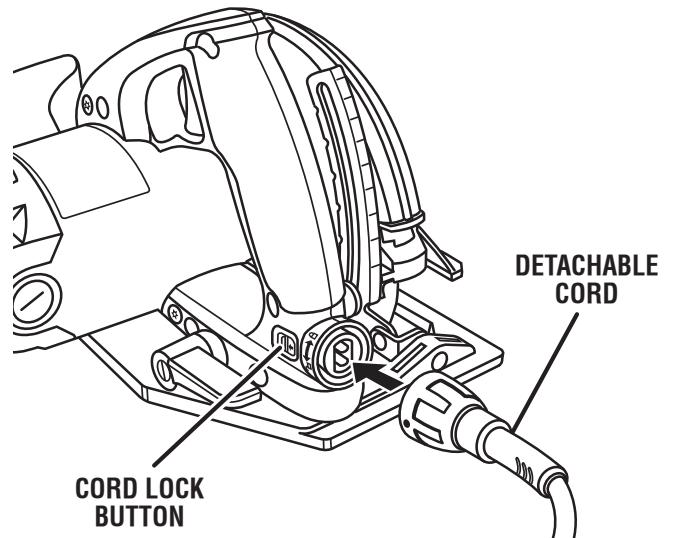

Fig. 9

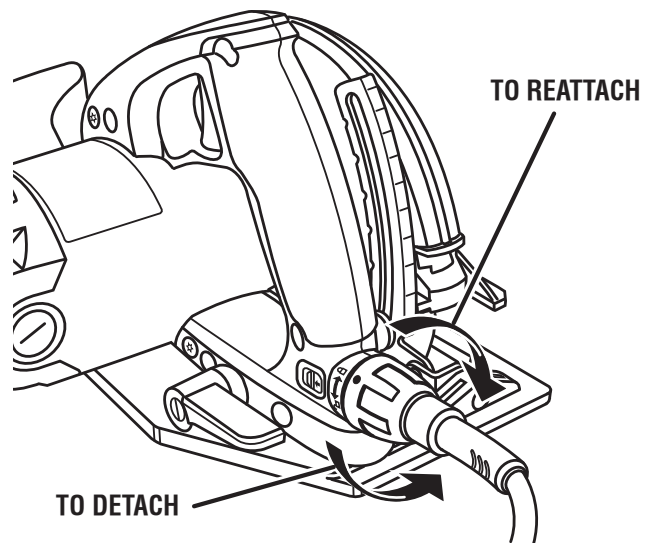

Fig. 10

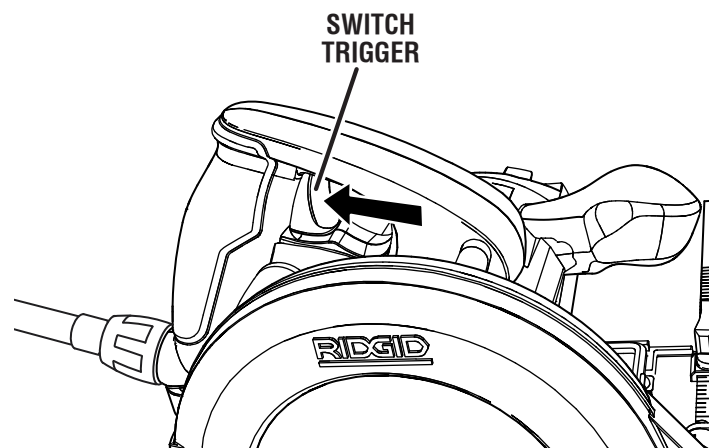

Fig. 11

OPERATION

ADJUSTING BLADE DEPTH

See Figures 12 - 13.

Always keep correct blade depth setting. The correct blade depth setting for all cuts should not exceed 1/4 in. below the material being cut. More blade depth will increase the chance of kickback and cause the cut to be rough.

- Unplug the saw.
- Pull depth adjustment lever upward to release.
- Determine the desired depth of cut.
- Hold base flat against the workpiece and raise or lower saw until the indicator mark on the saw aligns with the desired depth on the scale.
- Push down on depth adjustment lever to lock into position.

INDEXING LEVERS

See Figure 13.

The levers on the saw can be repositioned for the best tightening position.

- Pull the lever out from the saw and move to desired position.
- Push lever back in and down to lock into place.
- Check to be sure the base is clamped securely.

PLYWOOD ID SYSTEM

See Figure 12.

Indicators along the elevation bracket help to quickly identify the following common plywood thicknesses: 1/4, 3/8, 1/2, 5/8, 3/4, and 1 in. A “click” can be heard as the saw is moved from one thickness setting to the next.

- Unplug the saw.
- Pull depth adjustment lever upward to release.
- Determine the thickness of the workpiece.
- Hold base flat against the workpiece and raise or lower saw until the saw clicks into the correct thickness setting.
- Push down on depth adjustment lever to lock into position.

NOTE: Saw teeth will extend slightly further than the selected thickness setting to allow the blade to pass completely through the workpiece.

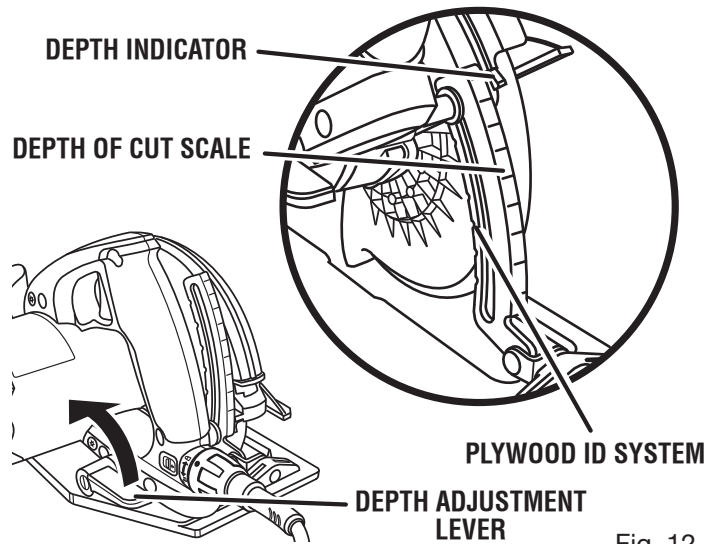

Fig. 12

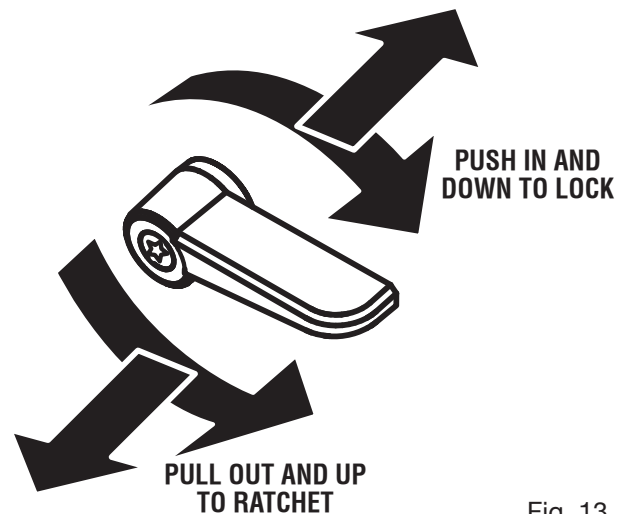

Fig. 13

OPERATION

OPERATING THE SAW

See Figures 14 - 16.

Refer to the figures in this section to learn the correct and incorrect ways for handling the saw.

WARNING:

To make sawing easier and safer, always maintain proper control of the saw. Loss of control could cause an accident resulting in possible serious injury.

DANGER:

When lifting the saw from the workpiece, the blade is exposed on the underside of the saw until the lower blade guard closes. Make sure the lower blade guard is closed before setting the saw down.

To make the best possible cut, follow these helpful hints.

- Hold the saw firmly with both hands.
- Avoid placing your hand on the workpiece while making a cut.
- Support the workpiece so that the cut (kerf) is always to your side.
- Support the workpiece near the cut.
- Clamp the workpiece securely so that the workpiece will not move during the cut.
- Always place the saw on the workpiece that is supported, not the “cut off” piece.
- Place the workpiece with the “good” side down.
- Draw a guideline along the desired line of cut before beginning the cut.
- Keep the cord away from the cutting area. Always place the cord to prevent it from hanging up on the workpiece while making a cut.

DANGER:

If the cord hangs up on the workpiece during a cut, release the switch trigger immediately. Unplug the saw and reposition the cord to prevent it from hanging up again.

DANGER:

Using a saw with a damaged cord could result in serious injury or death. If the cord has been damaged, have it replaced before using the saw again.

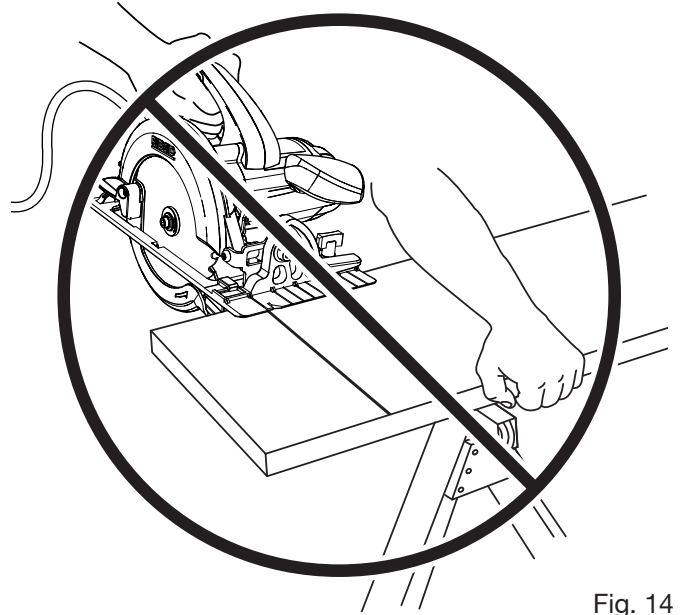

Fig. 14

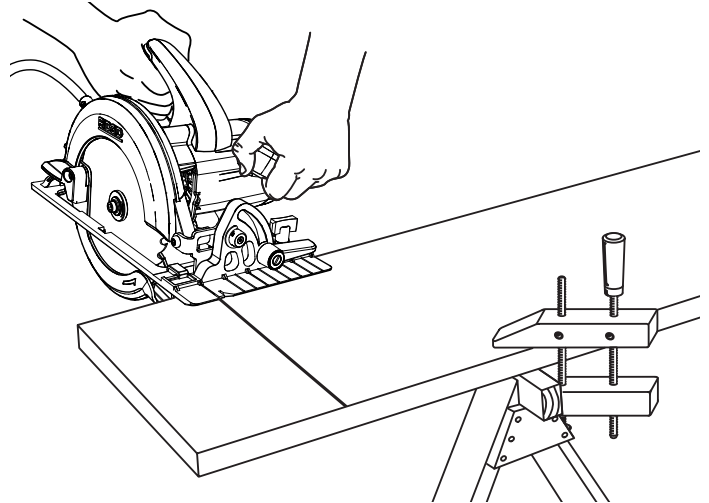

Fig. 15

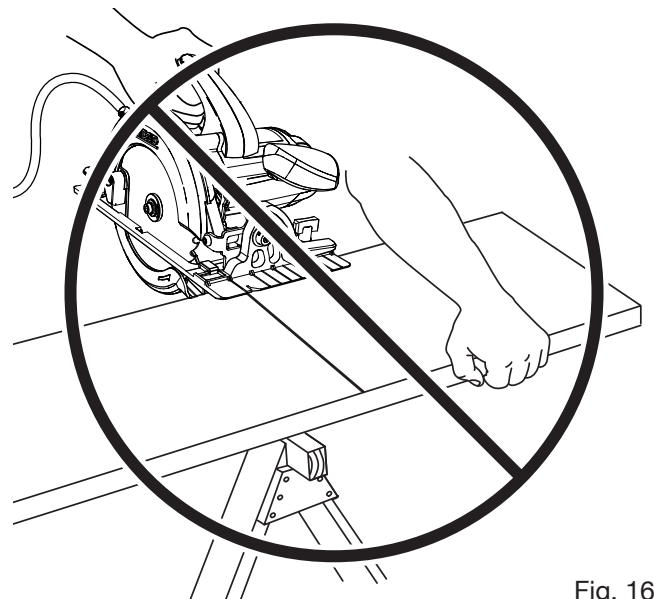

Fig. 16

OPERATION

CROSS CUTTING/RIP CUTTING

See Figures 17 - 19.

When making a cross cut or rip cut, align the guideline with the full length kerf indicator on the base as shown in the figure. The distance from the saw blade to the saw base is approximately 5 in. on the left side of the saw and 1 in. on the right side.

Since blade thicknesses vary, always make a trial cut in scrap material along a guideline to determine how much the guideline must be offset from the guide to produce an accurate cut.

NOTE: The distance from the line of cut to the guideline is the amount you should offset the guide.

TO RIP CUT

See Figures 18 - 19.

Use a guide when making long or wide rip cuts with the saw.

To rip cut using optional edge guide:

- Slide edge guide into the slot.
- Align the guideline with the full length kerf indicator on the base.
- Adjust the guide so that the “0” on the guide is aligned with the edge of the workpiece.
- Secure the guide with the lock knob provided with the saw.
- Secure the workpiece.
- Position the face of the edge guide firmly against the edge of workpiece.

NOTE: The guiding edge of the workpiece must be straight for your cut to be straight. Use caution to prevent the blade from binding in the cut.

- Saw along workpiece keeping guide firmly against edge to achieve a straight rip cut.

To rip cut using a straight edge:

- Secure the workpiece.
- Clamp a straight edge to the workpiece using C-clamps.

NOTE: Position C-clamps so they will not interfere with the saw housing during the cut.

- Saw along the straight edge to achieve a straight rip cut.

NOTE: Do not bind the blade in the cut.

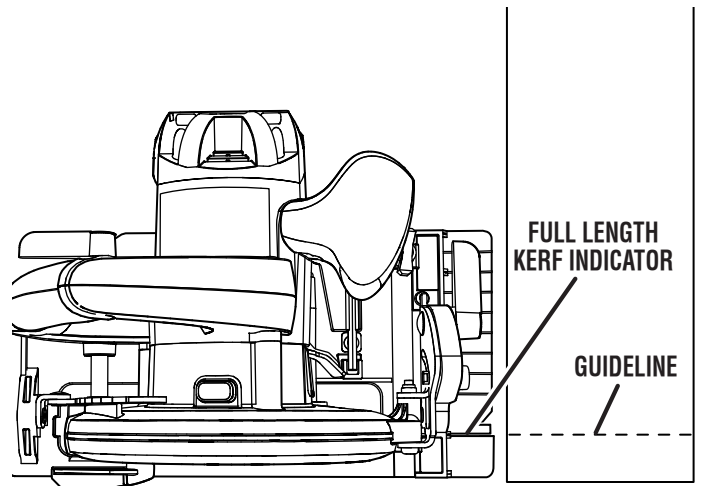

Fig. 17

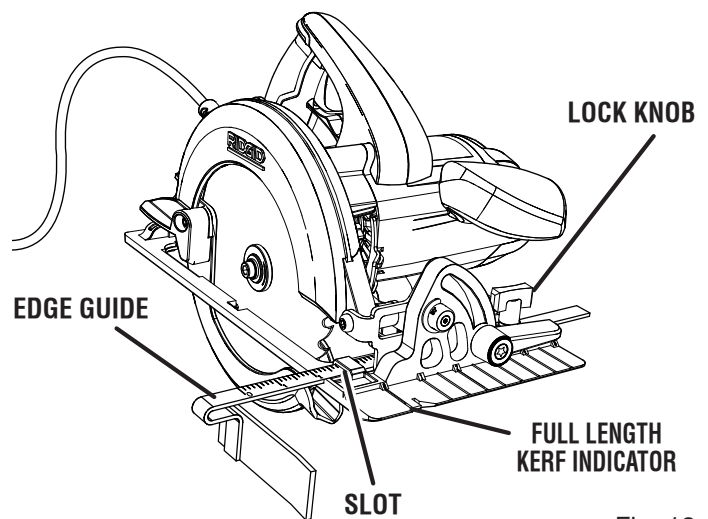

Fig. 18

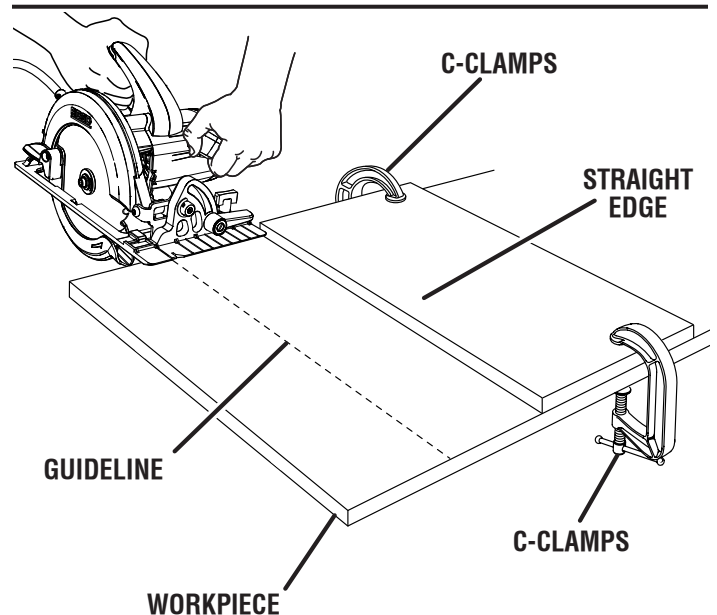

Fig. 19

OPERATION

BEVEL CUTTING

See Figures 20 - 22.

To make the best possible cut, follow these helpful hints.

- Align the line of cut with the inner blade guide notch on the base when making 45° bevel cuts.
- Make a trial cut in scrap material along a guideline to determine how much you should offset the guideline on the cutting material.
- Adjust the angle of cut to any desired setting between zero and 50°. Positive stops are located at 0°, 45°, and 50°. Refer to **To Adjust Bevel Setting** later in this manual.

NOTE: Push the positive 50° stop button in while raising the motor housing to set the bevel setting above 45° and up to 50°.

TO ADJUST BEVEL SETTING

See Figures 20 - 21.

- Unplug the saw.
- Pull the bevel adjustment lever upward until the motor housing moves freely.
- Raise motor housing end of saw until you reach the desired angle setting on bevel scale.

NOTE: Positive stops are located at 0°, 45°, and 50°. Push the positive 50° stop button in while raising the motor housing to set the bevel setting above 45° and up to 50°.

- Push downward on the bevel adjustment lever until the motor housing is securely locked in place.

INDEXING LEVERS

See Figure 21.

The levers on the saw can be repositioned for the best tightening position.

- Pull the lever out from the saw and move to desired position.
- Push lever back in and down to lock into place.
- Check to be sure the base is clamped securely.

⚠ WARNING:

Attempting a bevel cut without having the bevel adjustment lever securely locked in place can result in serious injury.

TO BEVEL CUT

See Figure 22.

- Hold the saw firmly with both hands as shown.
- Rest the front edge of the base on the workpiece.
- Start the saw and let the blade reach full speed.
- Guide the saw into the workpiece and make the cut.
- Release the trigger and allow the blade to come to a complete stop.
- Lift the saw from the workpiece.

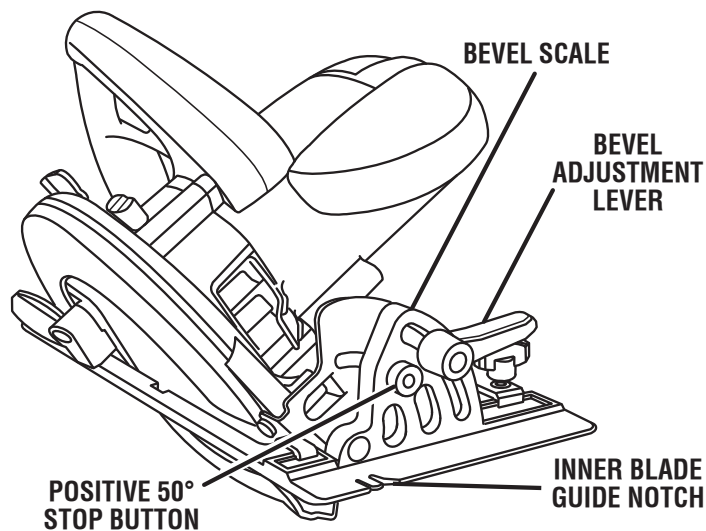

Fig. 20

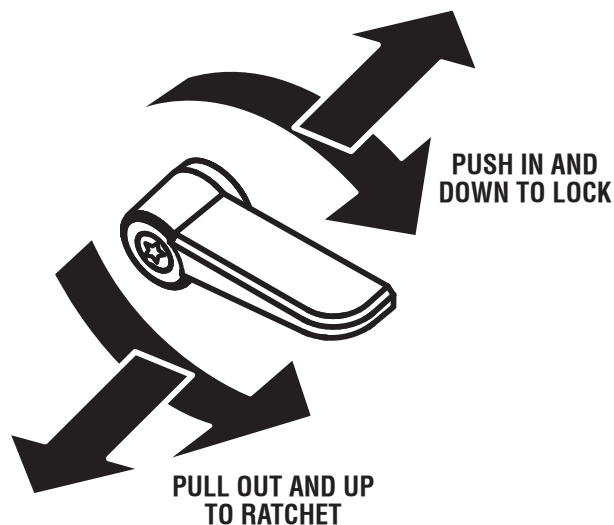

Fig. 21

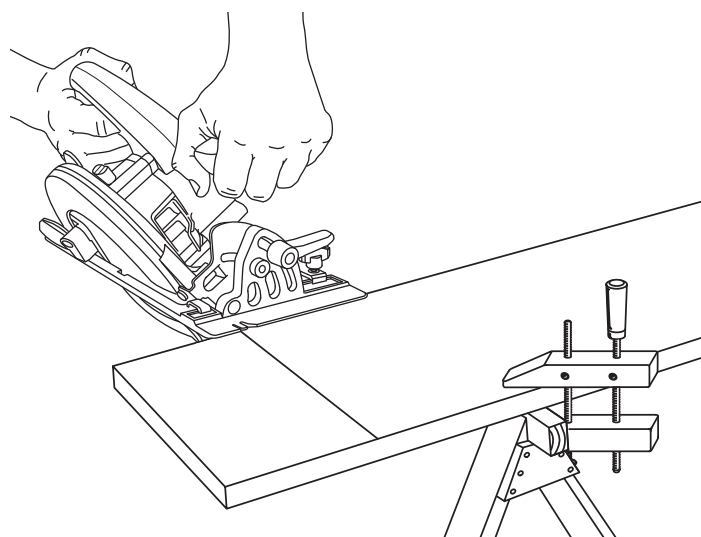

Fig. 22

OPERATION

POCKET CUTTING

See Figure 23.

WARNING:

Always adjust bevel setting to zero before making a pocket cut. Attempting a pocket cut at any other setting can result in loss of control of the saw possibly causing serious injury.

- Adjust the bevel setting to zero.
- Set the blade to the correct blade depth setting.
- Swing the lower blade guard up using the lower blade guard handle.

NOTE: Always raise the lower blade guard with the handle to avoid serious injury.

- Hold the lower blade guard by the handle.
- Rest the front of the base flat against the workpiece with the rear of the handle raised so the blade does not touch the workpiece.
- Start the saw and let the blade reach full speed.
- Guide the saw into the workpiece and make the cut.

WARNING:

Always cut in a forward direction when pocket cutting. Cutting in the reverse direction could cause the saw to climb up on the workpiece and back toward you.

ADJUSTMENTS

WARNING:

Before performing any adjustment, make sure the tool is unplugged from the power supply and the switch is in the **OFF (O)** position. Failure to heed this warning could result in serious personal injury.

POSITIVE 0° BEVEL STOP

See Figure 24.

The saw has a positive 0° bevel stop that has been factory adjusted to assure 0° angle of the saw blade when making 90° cuts. However, misalignment can occur during shipping.

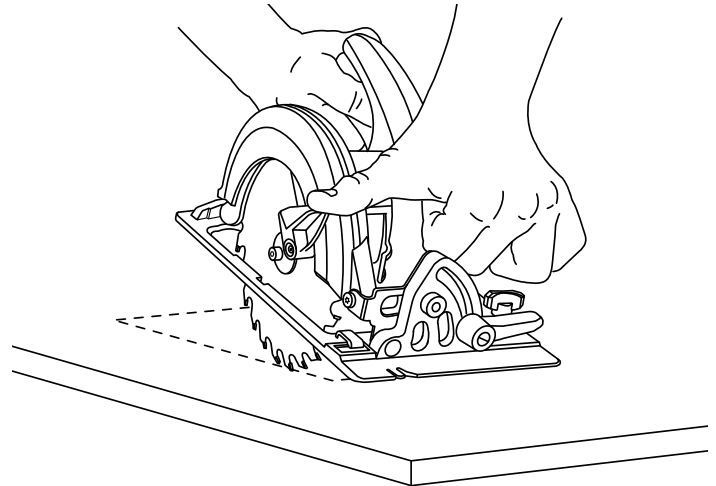

Fig. 23

- Release the trigger and allow the blade to come to a complete stop.
- Lift the saw from the workpiece.
- Clear corners out with a hand saw or sabre saw.

WARNING:

Never tie the lower blade guard in a raised position. Leaving the blade exposed could lead to serious injury.

To check positive 0° bevel stop:

- Unplug the saw.
- Place saw in an upside down position on a workbench.
- Move the lower blade guard out of the way so that the saw blade is exposed.
- Check the squareness of the saw blade to the base of the saw using a combination square.

ADJUSTMENTS

To adjust positive 0° bevel stop:

- Unplug the saw.
- Pull bevel adjustment lever upward to release.
- Turn T8 setscrew with hex key (not provided) and adjust base until it is square with the saw blade.
- Securely lock the bevel adjustment lever.

WARNING:

Attempting a bevel cut without having the bevel adjustment lever securely locked in place can result in serious injury.

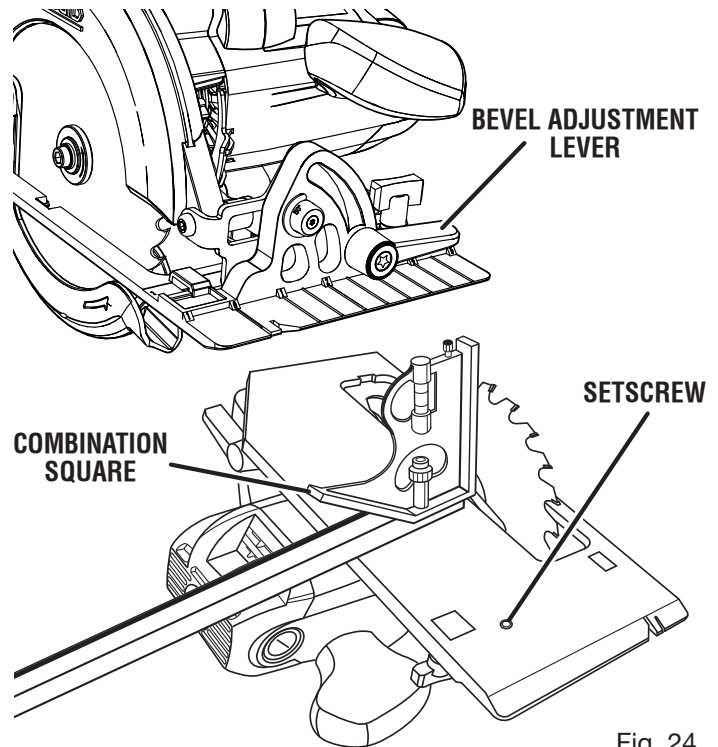

MAINTENANCE

WARNING:

When servicing use only identical RIDGID replacement parts. Use of any other parts may create a hazard or cause product damage.

WARNING:

Always wear safety goggles or safety glasses with side shields during power tool operation or when blowing dust. If operation is dusty, also wear a dust mask.

GENERAL MAINTENANCE

Avoid using solvents when cleaning plastic parts. Most plastics are susceptible to damage from various types of commercial solvents and may be damaged by their use. Use clean cloths to remove dirt, dust, oil, grease, etc.

WARNING:

Do not at any time let brake fluids, gasoline, petroleum-based products, penetrating oils, etc., come in contact with plastic parts. Chemicals can damage, weaken or destroy plastic which may result in serious personal injury.

Electric tools used on fiberglass material, wallboard, spackling compounds, or plaster are subject to accelerated wear and possible premature failure because the fiberglass chips and grindings are highly abrasive to bearings, brushes, commutators, etc. Consequently, we do not recommend using this tool for extended work on these types of materials. However, if you do work with any of these materials, it is extremely important to clean the tool using compressed air.

LUBRICATION

All of the bearings in this tool are lubricated with a sufficient amount of high grade lubricant for the life of the unit under normal operating conditions. Therefore, no further lubrication is required.

MAINTENANCE

CHECKING/REPLACING EXTERNAL BRUSHES

See Figure 25.

NOTE: The saw is equipped with externally accessible brushes.

- Unplug the saw.

WARNING:

Failure to unplug the tool could result in accidental starting causing possible serious injury.

NOTE: Brush caps (2) are located on each side of the motor housing.

- Remove brush caps (2) using a screwdriver.
- Remove brush assemblies (2).
- Check for wear. Replace both brush assemblies when either has less than 1/4 in. length of carbon remaining.

NOTE: Do not replace one side without replacing the other.

- Reassemble using new brush assemblies. Make sure curvature of brush matches curvature of motor and that brush moves freely in brush tube.
- Reassemble by reversing the steps listed above.
- Tighten all brush caps securely. **Do not** over tighten.

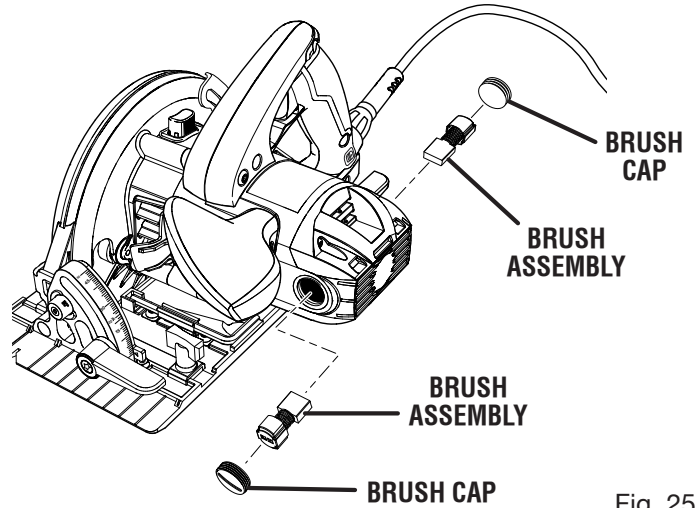

Fig. 25

ACCESSORIES

Look for these accessories where you purchased this product:

- Edge Guide 631697001

WARNING:

Current attachments and accessories available for use with this tool are listed above. Do not use any attachments or accessories not recommended by the manufacturer of this tool. The use of attachments or accessories not recommended can result in serious personal injury.

WARRANTY

RIDGID® HAND HELD AND STATIONARY POWER TOOL 3 YEAR LIMITED SERVICE WARRANTY

Proof of purchase must be presented when requesting warranty service.

Limited to RIDGID® hand held and stationary power tools purchased 2/1/04 and after. This product is manufactured by One World Technologies, Inc. The trademark is licensed from RIDGID, Inc. All warranty communications should be directed to One World Technologies, Inc., attn: RIDGID Hand Held and Stationary Power Tool Technical Service at (toll free) 1-866-539-1710.

90-DAY SATISFACTION GUARANTEE POLICY

During the first 90 days after the date of purchase, if you are dissatisfied with the performance of this RIDGID® Hand Held and Stationary Power Tool for any reason you may return the tool to the dealer from which it was purchased for a full refund or exchange. To receive a replacement tool you must present proof of purchase and return all original equipment packaged with the original product. The replacement tool will be covered by the limited warranty for the balance of the 3 YEAR service warranty period.

WHAT IS COVERED UNDER THE 3 YEAR LIMITED SERVICE WARRANTY

This warranty on RIDGID® Hand Held and Stationary Power Tools covers all defects in workmanship or materials and normal wear items such as brushes, chucks, motors, switches, cords, gears and even cordless batteries in this RIDGID® tool for three years following the purchase date of the tool. Warranties for other RIDGID® products may vary.

HOW TO OBTAIN SERVICE

To obtain service for this RIDGID® tool you must return it; freight prepaid, or take it in to an authorized service center for RIDGID® branded hand held and stationary power tools. You may obtain the location of the authorized service center nearest you by calling (toll free) 1-866-539-1710 or by logging on to the RIDGID® website at www.ridgid.com. When requesting warranty service, you must present the original dated sales receipt. The authorized service center will repair any faulty workmanship, and either repair or replace any part covered under the warranty, at our option, at no charge to you.

WHAT IS NOT COVERED

This warranty applies only to the original purchaser at retail and may not be transferred. This warranty only covers defects arising under normal usage and does not cover any malfunction, failure or defect resulting from misuse, abuse, neglect, alteration, modification or repair by other than an authorized service center for RIDGID® branded hand held and stationary power tools. Consumable accessories provided with the tool such as, but not limited to, blades, bits and sand paper are not covered.

RIDGID, INC. AND ONE WORLD TECHNOLOGIES, INC. MAKE NO WARRANTIES, REPRESENTATIONS OR PROMISES AS TO THE QUALITY OR PERFORMANCE OF ITS POWER TOOLS OTHER THAN THOSE SPECIFICALLY STATED IN THIS WARRANTY.

ADDITIONAL LIMITATIONS

To the extent permitted by applicable law, all implied warranties, including warranties of MERCHANTABILITY or FITNESS FOR A PARTICULAR PURPOSE, are disclaimed. Any implied warranties, including warranties of merchantability or fitness for a particular purpose, that cannot be disclaimed under state law are limited to three years from the date of purchase. One World Technologies, Inc. and RIDGID, Inc. are not responsible for direct, indirect, incidental or consequential damages. Some states do not allow limitations on how long an implied warranty lasts and/or do not allow the exclusion or limitation of incidental or consequential damages, so the above limitations may not apply to you. This warranty gives you specific legal rights, and you may also have other rights which vary from state to state.

One World Technologies, Inc.

P.O. Box 35, Hwy. 8
Pickens, SC 29671

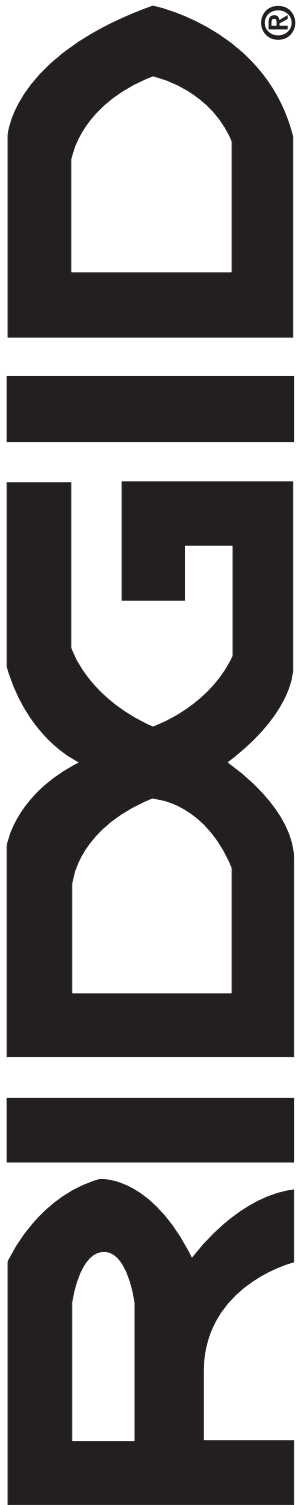

OPERATOR'S MANUAL

6-1/2 in. CIRCULAR SAW DOUBLE INSULATED R3203-1

Customer Service Information:

For parts or service, contact your nearest RIDGID authorized service center. Be sure to provide all relevant information when you call or visit. For the location of the authorized service center nearest you, please call 1-866-539-1710 or visit us online at www.ridgid.com.

The model number of this tool is found on a plate attached to the motor housing. Please record the serial number in the space provided below. When ordering repair parts, always give the following information:

Model No. _____ R3203-1 _____

Serial No. _____