



## INSTALLATION INSTRUCTIONS FOR PART 95-7337B

### APPLICATIONS

## KIA Soul 2010

# 95-7337B

### KIT FEATURES

- DDIN Head Unit Provision
- ISO Stacked Head Unit Provision
- Painted Matte Black



### KIT COMPONENTS

A) Double DIN Trim Plate B) Double DIN Brackets

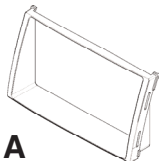

A

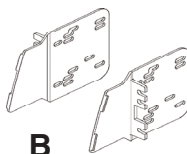

B

### WIRING AND ANTENNA CONNECTIONS (Sold Separately)

#### Harness:

- 70-7303 - Kia / Hyundai Harness 2009-up

#### Antenna Adapter:

- 40-KI11 - Kia / Hyundai Antenna Adapter 2007-up

### TOOLS REQUIRED:

- Small Flat Blade Screwdriver
- Panel Removal Tool
- Phillips Screwdriver



1-800-221-0932



www.metraonline.com

© COPYRIGHT 2007-2009

METRA ELECTRONICS CORPORATION

## **TABLE OF CONTENTS**

### **Dash Disassembly**

**- KIA Soul 2010 ..... 1**

### **Kit Assembly**

**- DDIN / Stacked ISO DIN Head Unit Provisions ..... 2**

**Final Assembly ..... 3**

**\*Note:**

**Refer also to the instructions included with the aftermarket radio.**



### **KNOWLEDGE IS POWER**

Enhance your installation and fabrication skills by enrolling in the most recognized and respected mobile electronics school in our industry. Log onto [www.installerinstitute.com](http://www.installerinstitute.com) or call 800-354-6782 for more information and take steps toward a better tomorrow.



Metra recommends MECP certified technicians.

**KIA SOUL 2010**

- 1** Disconnect the negative battery terminal to prevent an accidental short circuit.
- 2** Unclip and remove the radio/climate control trim panel. (Figure A)
- 3** Remove (4) Phillips screws securing the climate control. (Figure B)
- 4** Remove (4) Phillips screws securing the radio. (Figure C)

*Continue to kit assembly.*

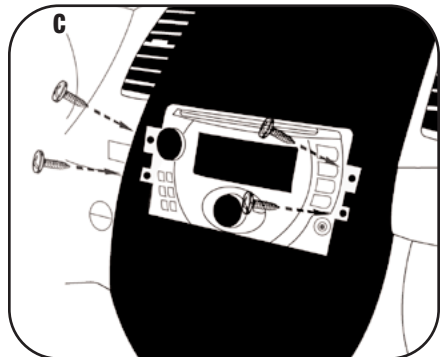
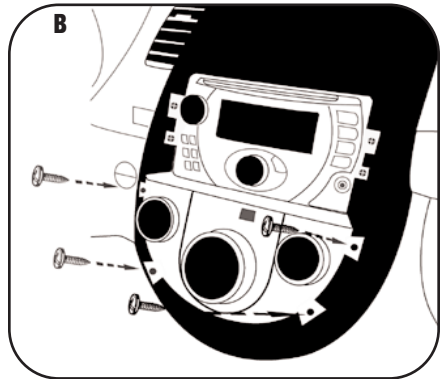
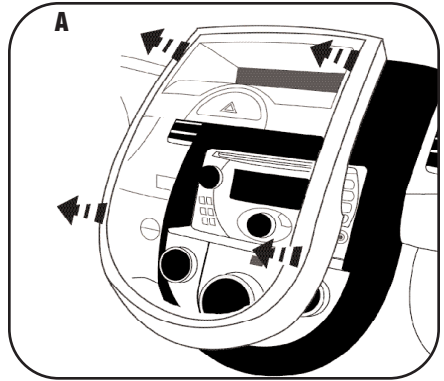

**DOUBLE DIN / STACKED ISO DIN HEAD UNIT PROVISIONS**

*\*Note: Refer also to the instructions included with the aftermarket radio.*

- 1** Locate the factory wiring harness in the dash. Metra recommends using the proper mating adapter from Metra or AXXESS. Re-connect the negative battery terminal and test the unit for proper operation.
- 2** Attach the Double DIN brackets to the Double DIN Trim Plate. (Figure A)
- 3** Slide the radio into the bracket/radio housing assembly and secure using the screws supplied with the radio. (Figure B)
- 4** Reassemble dash in reverse order of disassembly.

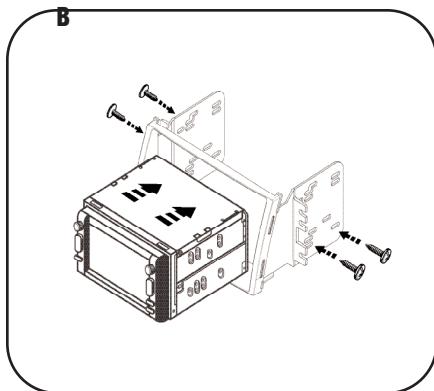
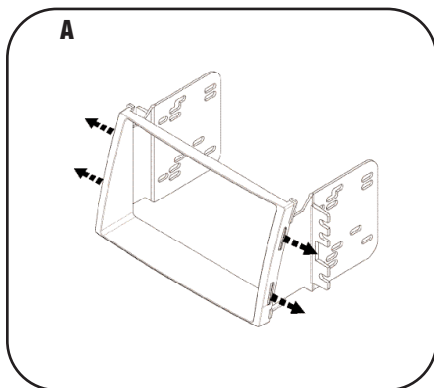

# 95-7337B INSTRUCTIONS

## NOTES

---

---

---

---

---

---

---

---

---

---

---

# 95-7337B INSTRUCTIONS

## NOTES

---

---

---

---

---

---

---

---

---

---

---

---

---

---

**NOTES**

---

---

---

---

---

---

---

---

---

---

---

---

---

# 95-7337B INSTRUCTIONS



**1-800-221-0932**



**[www.metraonline.com](http://www.metraonline.com)**

REV. 11/03/09 © COPYRIGHT 2003-2009 METRA ELECTRONICS CORPORATION INST95-7337B