

# **SIM100**

# **Switch Indicator Module**

## **User's Manual**

**Revision 1.0**

**Copyright © 2008 Maretron, LLP All Rights Reserved**

**Maretron, LLP**  
**9014 N. 23<sup>rd</sup> Ave #10**  
**Phoenix, AZ 85021-7850**  
**<http://www.maretron.com>**

**Maretron Manual Part #: M001801**

## **Revision History**

<b>Revision</b>	<b>Description</b>
1.0	Original document

## Table of Contents

1	Introduction .....	1
1.1	Firmware Revision .....	1
1.2	SIM100 Features .....	1
1.3	Quick Install .....	2
2	Installation .....	2
2.1	Unpacking the Box .....	2
2.2	Choosing a Mounting Location .....	2
2.3	Mounting the SIM100 .....	3
2.4	Connecting the SIM100 .....	3
2.4.1	NMEA 2000® Connection .....	3
2.4.2	Switch Connections .....	4
2.4.2.1	Switch With End of Line Resistor .....	5
2.4.2.2	Switch Without End of Line Resistor .....	5
2.4.3	Checking Connections .....	6
2.5	Configuring the SIM100 .....	6
2.5.1	Device Instance .....	6
2.5.2	Channel #1 Mode .....	6
2.5.3	Channel #2 Mode .....	6
2.5.4	Channel #3 Mode .....	6
2.5.5	Channel #4 Mode .....	6
2.5.6	Channel #5 Mode .....	6
2.5.7	Channel #6 Mode .....	6
2.5.8	Advanced Configuration .....	7
2.5.9	NMEA 2000® PGN Enable/Disable .....	7
2.5.10	Restore Factory Defaults .....	7
3	Maintenance .....	7
4	Troubleshooting .....	7
5	Technical Specifications .....	9
6	Technical Support .....	10
7	Installation Template .....	11
8	Maretron (2 Year) Limited Warranty .....	12

## Table of Figures

Figure 1	– Mounting the SIM100 .....	3
Figure 2	– NMEA 2000® Connector Face Views .....	4
Figure 3	– Switch With End of Line Resistor Connection Diagram .....	5
Figure 4	– Switch Without End of Line Resistor Connection Diagram .....	5
Figure 6	– Mounting Surface Template .....	11

## Table of Appendices

Appendix A	– NMEA 2000® Interfacing .....	A1
------------	--------------------------------	----



## 1 Introduction

Congratulations on your purchase of the Maretron Switch Indicator Module. Maretron has designed and built your SIM100 to the highest standards for years of dependable and accurate service.

Maretron's Switch Indicator Module monitors switch closure devices including, but not limited to, safety equipment (e.g., heat, smoke, carbon monoxide, explosive vapor detectors), security systems (e.g., motion, vibration, glass break, door and port hole magnetic switches), and vessel monitoring equipment (e.g., valve closed/open, high water bilge). The SIM100 continually monitors these switch closure devices and broadcasts information over the NMEA 2000 network about the switch state so the crew can be alerted to potential conditions or problems that warrant further investigation. Advanced features of the SIM100 include the ability to detect whether or not power has been disconnected from the monitored device or if the signal wires have been disconnected due to either corrosion, tampering, or for any other reason (if the monitored device is so equipped). With the SIM100, you can rest assured that critical sensors are receiving power, signal wires are connected, and all the safety, security and vessel functions are under constant supervision.

The Maretron SIM100 is designed to operate within the harsh demands of the marine environment. However, no piece of marine electronic equipment can function properly unless installed, configured, and maintained in the correct manner. Please read carefully and follow these instructions for installation, configuration, and usage of the Maretron SIM100 in order to ensure optimal performance.

### 1.1 Firmware Revision

This manual corresponds to SIM100 firmware revision 1.0.0.

### 1.2 SIM100 Features

The Maretron SIM100 has the following features.

- NMEA 2000® Interface
- Waterproof Connectors
- Sealed Waterproof Enclosure
- Opto-Isolated from NMEA 2000® Eliminating Potential Ground Loops
- Monitors and reports switch status
- Can detect and report problems like opens and shorts in switch circuits
- Compatible with Maretron-Supplied
  - Heat Detectors
  - Smoke Detectors
  - Carbon Monoxide Detectors
  - Bilge Water Detectors
- Also Compatible With
  - Magnetic Switches
  - Glass Break Detectors
  - Door, Hatch, and Porthole Magnetic Switches

## **1.3 SIM100 Accessories**

Maretron offers the following accessories for the SIM100:

- SH-499CSTE Smoke/Heat Detector
- CO1000-S-W Carbon Monoxide (CO) Detector (Surface Mount White)
- LP1000-S-W Liquid Petroleum (LP) Detector (Surface Mount White)
- BHW100 Bilge High Water Detector
- MD-6157-N Motion Detector
- MS-1035 Magnetic Switch Rectangular (Indoor)
- MS-1085-N Magnetic Switch Rectangular (Outdoor)
- MS-1055-N Magnetic Switch Cylinder (Indoor/Outdoor)
- MS-1075 Magnetic Switch Recessed (Indoor/Outdoor)

## **1.4 Quick Install**

Installing the Maretron SIM100 involves the following five steps. Please refer to the individual sections for additional details.

1. Unpack the box (Section 2.1)
2. Choose a mounting location (Section 2.2)
3. Mount the SIM100 (Section 2.3)
4. Connect the SIM100 (Section 0)
5. Configure the SIM100 (Section 2.5)

## **2 Installation**

### **2.1 Unpacking the Box**

When unpacking the box containing the Maretron SIM100, you should find the following items:

- 1 – SIM100 – Switch Indicator Module
- 1 – Parts Bag containing 4 Stainless Steel Mounting Screws
- 1 – SIM100 User's Manual
- 1 – Warranty Registration Card

If any of these items are missing or damaged, please contact Maretron.

### **2.2 Choosing a Mounting Location**

Please consider the following when choosing a mounting location.

1. The SIM100 is waterproof, so it can be mounted in a damp or dry location.
2. The orientation is not important, so the SIM100 can be mounted on a horizontal deck, vertical bulkhead, or upside down if desired.
3. The SIM100 is temperature-rated to 55°C (130°F), so it should be mounted away from engines or engine rooms where the operating temperature exceeds the specified limit.

## 2.3 Mounting the SIM100

Attach the SIM100 securely to the vessel using the included stainless steel mounting screws or other fasteners as shown in Figure 1 below.

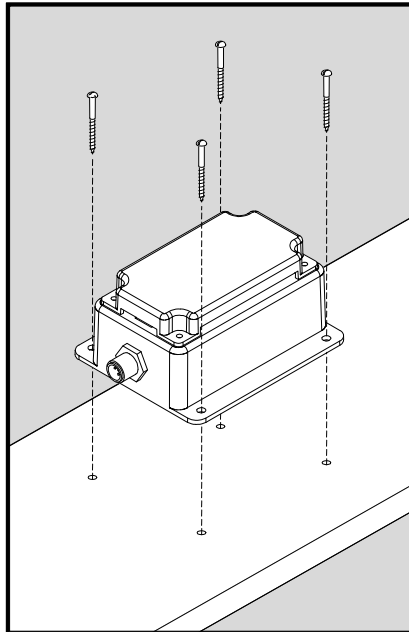

**Figure 1 – Mounting the SIM100**

## 2.4 Connecting the SIM100

The SIM100 requires two types of electrical connections: 1) the NMEA 2000® connection (refer to Section 2.4.1), and 2) the switch connections, which are described in Section 2.4.2.

### 2.4.1 NMEA 2000® Connection

The NMEA 2000® connector can be found on the side of the enclosure. The NMEA 2000® connector is a round five pin male connector (see Figure 2). You connect the SIM100 to an NMEA 2000® network using a Maretron NMEA 2000® cable (or compatible cable) by connecting the female end of the cable to the SIM100 (note the key on the male connector and keyway on the female connector). Be sure the cable is connected securely and that the collar on the cable connector is tightened firmly. Connect the other end of the cable (male) to the NMEA 2000® network in the same manner. The SIM100 is designed such that you can plug or unplug it from an NMEA 2000® network while the power to the network is connected or disconnected. Please follow recommended practices for installing NMEA 2000® network products.

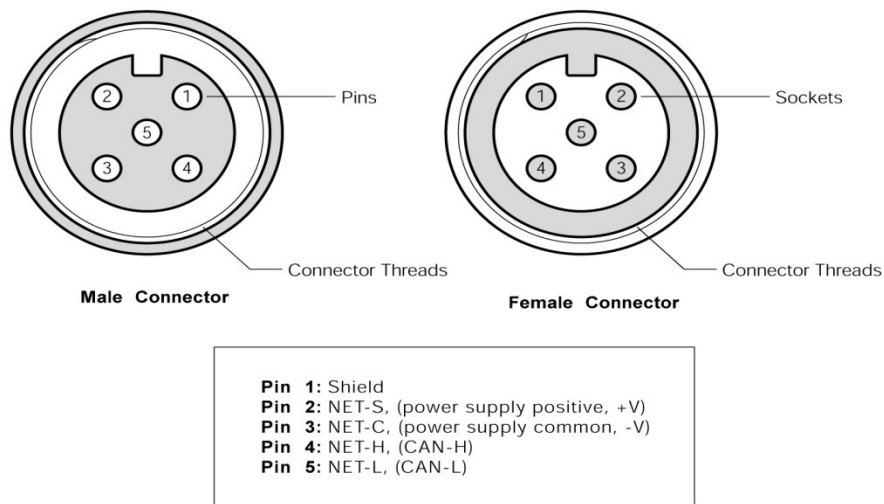

**Figure 2 – NMEA 2000® Connector Face Views**

## 2.4.2 Switch Connections

The SIM100 switch connections are made by connecting to the 12-pin terminal strip on the top of the unit. First, remove the four screws at the corners of the unit detaching the splash guard from the unit. On the bottom of the splash guard, you will find a label detailing the wire connection to pin number assignments, which are repeated in the table below.

Pin #	Signal Name	Connection
1	SW1A	Switch #1 Signal A
2	SW1B	Switch #1 Signal B
3	SW2A	Switch #2 Signal A
4	SW2B <sub>i</sub>	Switch #2 Signal B
5	SW3A <sub>i</sub>	Switch #3 Signal A
6	SW3B	Switch #3 Signal B
7	SW4A	Switch #4 Signal A
8	SW4B	Switch #4 Signal B
9	SW5A	Switch #5 Signal A
10	SW5B	Switch #5 Signal B
11	SW6A	Switch #6 Signal A
12	SW6B	Switch #6 Signal B

Before attempting to connect the SIM100 to the AC source, determine the type of system you will be monitoring. The SIM100 supports the connection and monitoring of two different system types; 1) switch with end-of-line resistor (Section 2.4.2.1), or 2) switch without end-of-line resistor (Section 2.4.2.2). To connect Maretron SIM100 accessories, please refer to the installation directions that accompany each accessory.



## 2.4.2.1 Switch With End of Line Resistor

Please refer to Figure 3 for connecting the SIM100 to a switch with an end of line resistor. This figure shows the connection of the monitored switch to switch channel 1 via the terminals named SW1A and SW1B. Connections to other switch terminals are similar.

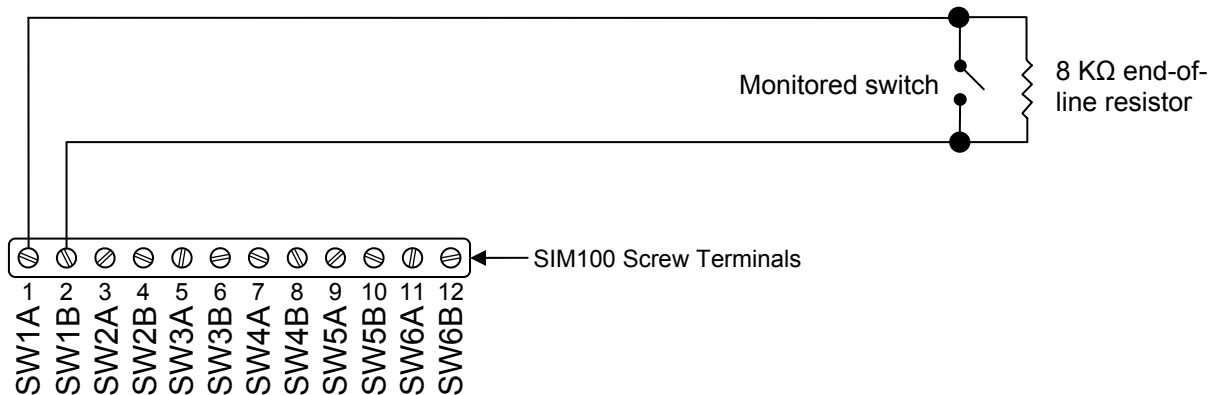

**Figure 3 – Switch With End of Line Resistor Connection Diagram**

## 2.4.2.2 Switch Without End of Line Resistor

Please refer to Figure 4 for connecting the SIM100 to a switch without an end of line resistor. This figure shows the connection of the monitored switch to switch channel 1 via the terminals named SW1A and SW1B. Connections to other switch terminals are similar.

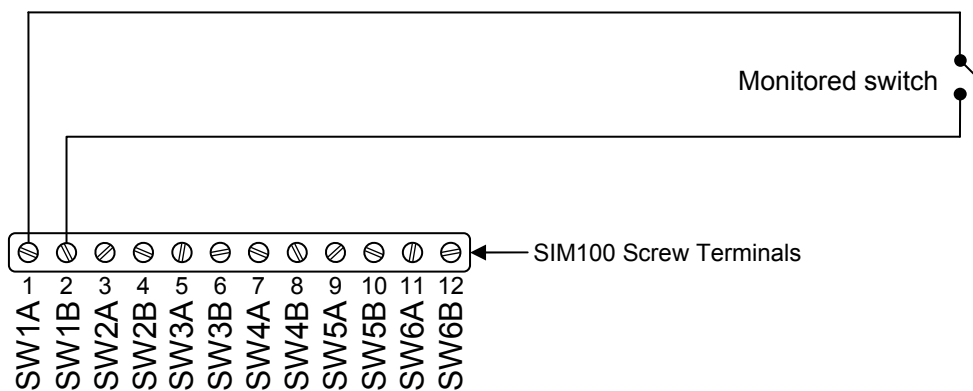

**Figure 4 – Switch Without End of Line Resistor Connection Diagram**

## **2.4.3 Checking Connections**

Once the NMEA 2000<sup>®</sup> connection and switch connection(s) to the SIM100 have been completed, check to see that information is being properly transmitted by observing an appropriate NMEA 2000<sup>®</sup> display. If you don't see switch indicator status, refer to Section 5, "Troubleshooting".

## **2.5 Configuring the SIM100**

The SIM100 will transmit data over the NMEA 2000 network as it is shipped from the factory; however, it may require configuration, depending on the type of switch monitored. There are several configurable items within the SIM100, which are detailed in the remainder of this section.

You configure the SIM100 using a Maretron DSM250 display or other NMEA 2000<sup>®</sup> display unit that is capable of configuring the SIM100. Please refer to the Maretron *DSM250 User's Manual* for details.

### **2.5.1 Device Instance**

NMEA 2000<sup>®</sup> provides a unique device instance for each switch monitoring device on a vessel. This value should be programmed in each SIM100 so that each SIM100 is associated with a unique device instance number. The default instance number is 0, which is used to indicate the first SIM100 that is hooked to the network. Subsequent SIM100s connected to the network would be numbered 1, 2, and so on.

### **2.5.2 Channel #1 Mode**

### **2.5.3 Channel #2 Mode**

### **2.5.4 Channel #3 Mode**

### **2.5.5 Channel #4 Mode**

### **2.5.6 Channel #5 Mode**

### **2.5.7 Channel #6 Mode**

You must configure the SIM100 as to what type of switch circuit it is monitoring. The allowable values for this parameter are as follows:

- "End of Line Resistor" (default) – The switch circuit has a SPST switch connecting the A and B terminals, with a parallel 8 K $\Omega$  end-of-line resistor. This allows the SIM100 to monitor the circuit and indicate an error condition if the monitored circuit somehow becomes disconnected from the terminals on the SIM100.
- "No End of Line Resistor" – The switch circuit has a SPST switch connecting the A and B terminals, with a no parallel end-of-line resistor. The SIM100 is not able to monitor the circuit for disconnection in this case.
- "Disable" – Use this value if no switch circuit is connected to the corresponding switch terminals. The SIM100 will indicate that no data is available for this circuit.

## 2.5.8 Advanced Configuration...

Certain parameters do not normally need to be set in order for normal operation, but are included in an advanced configuration section for use in special situations.

## 2.5.9 NMEA 2000® PGN Enable/Disable

The SIM100 is capable of transmitting NMEA 2000® messages (or PGNs) associated with monitored switch circuits. You may individually enable or disable each of these messages. You may also change the rate of transmission of each of these messages if desired.

## 2.5.10 Restore Factory Defaults

Selecting this configuration option causes all stored parameters in the SIM100 to be reset to the values they contained when the unit was manufactured.

## 3 Maintenance

Regular maintenance is important to ensure continued proper operation of the Maretron SIM100. Perform the following tasks periodically:

- Clean the unit with a soft cloth. Do not use chemical cleaners as they may remove paint or markings or may corrode the SIM100 enclosure or seals.
- Ensure that the unit is mounted securely and cannot be moved relative to the mounting surface. If the unit is loose, tighten the mounting screws.
- Check the security of the cable connected to the NMEA 2000® connector, and tighten if necessary.
- Check the security of all of the switch connections on the top of the unit and tighten if necessary.

## 4 Troubleshooting

If you notice unexpected operation of the Maretron SIM100, follow the troubleshooting procedures in this section to remedy simple problems. If these steps do not solve your problem, please contact Maretron Technical Support (refer to Section 7 for contact information).

Symptom	Troubleshooting Procedure
No switch indicator data visible on NMEA 2000® network.	<p>Ensure that the SIM100 is properly connected to the NMEA 2000® network.</p> <p>Ensure that the switches are properly connected to the SIM100.</p> <p>Ensure that each indicator that you wish to monitor is not configured as “Disabled”.</p> <p>Ensure that the SIM100 has the appropriate NMEA 2000® PGNs enabled as described in Section 2.5.6.</p>

A switch indicator always reads "Closed"	Ensure that there is not a short circuit in the wiring for the switch. Measure the resistance between the "A" and "B" terminals for the appropriate indicator. If the switch is open, the resistance should either be an open-circuit, if the indicator is configured as "No End of Line Resistor", or should measure 8 K $\Omega$ if the indicator is configured as "End of Line Resistor". If the switch is closed, the resistance should be close to 0 $\Omega$ .
A switch indicator always reads "Error"	Ensure that the configuration of the indicator matches the circuit connected to it. Measure the resistance between the "A" and "B" terminals for the appropriate indicator. If the switch is open, the resistance should either be an open-circuit, if the indicator is configured as "No End of Line Resistor", or should measure 8 K $\Omega$ if the indicator is configured as "End of Line Resistor". If the switch is closed, the resistance should be close to 0 $\Omega$ .
A switch indicator always reads "Open"	Ensure that the switch is connected to the indicator terminals that that there are no open circuits between the SIM100 and the switch. Measure the resistance between the "A" and "B" terminals for the appropriate indicator. If the switch is open, the resistance should either be an open-circuit, if the indicator is configured as "No End of Line Resistor", or should measure 8 K $\Omega$ if the indicator is configured as "End of Line Resistor". If the switch is closed, the resistance should be close to 0 $\Omega$ .

## 5 Technical Specifications

As Maretron is constantly improving its products, all specifications are subject to change without notice. Maretron products are designed to be accurate and reliable; however, they should be used only as aids to navigation and not as a replacement for traditional navigation aids and techniques.

### Specifications

Parameter	Value	Comment
End of Line Resistor	8 K $\Omega$ $\pm$ 5%	Included with Maretron-supplied sensors

### Certifications

Parameter	Comment
NMEA 2000® Standard	Level A
Maritime Navigation and Radiocommunication Equipment & Systems	IEC 61162-3
Maritime Navigation and Radiocommunication Equipment & Systems	IEC 60945
FCC and CE Mark	Electromagnetic Compatibility

### NMEA 2000® Parameter Group Numbers (PGNs)

Description	PGN #	PGN Name	Default Rate
Periodic Data PGNs	127501	Binary Switch Bank Status	1 time/15 seconds and on switch change
Response to Requested PGNs	126464	PGN List (Transmit and Receive)	N/A
	126996	Product Information	N/A
	126998	Configuration Information	N/A
Protocol PGNs	059392	ISO Acknowledge	N/A
	059904	ISO Request	N/A
	060928	ISO Address Claim	N/A
	065240	ISO Address Command	N/A
	126208	NMEA Request/Command/Acknowledge	N/A
Maretron Proprietary PGNs	126720	Configuration	N/A

### Electrical

Parameter	Value	Comment
Operating Voltage	9 to 32 Volts	DC Voltage
Power Consumption	100 mA	NMEA 2000® Interface
Load Equivalence Number (LEN)	2	NMEA 2000® Spec. (1LEN = 50 mA)
Reverse Battery Protection	Yes	Indefinitely
Load Dump Protection	Yes	Energy Rated per SAE J1113

### Mechanical

Parameter	Value	Comment
Size	3.50" x 4.20" x 2.03" (88.9mm x 106.7mm x 51.6mm)	Including Flanges for Mounting
Weight	13 oz. (368.5 g)	

## **6 Technical Support**

If you require technical support for Maretron products, you can reach us in any of the following ways:

Telephone: 1-866-550-9100  
Fax: 1-602-861-1777  
E-mail: [support@maretron.com](mailto:support@maretron.com)  
World Wide Web: <http://www.maretron.com>  
Mail: Maretron, LLC  
Attn: Technical Support  
9014 N. 23<sup>rd</sup> Ave Suite 10  
Phoenix, AZ 85021 USA

## 7 Installation Template

Please check the dimensions before using the following diagram as a template for drilling the mounting holes because the printing process may have distorted the dimensions.

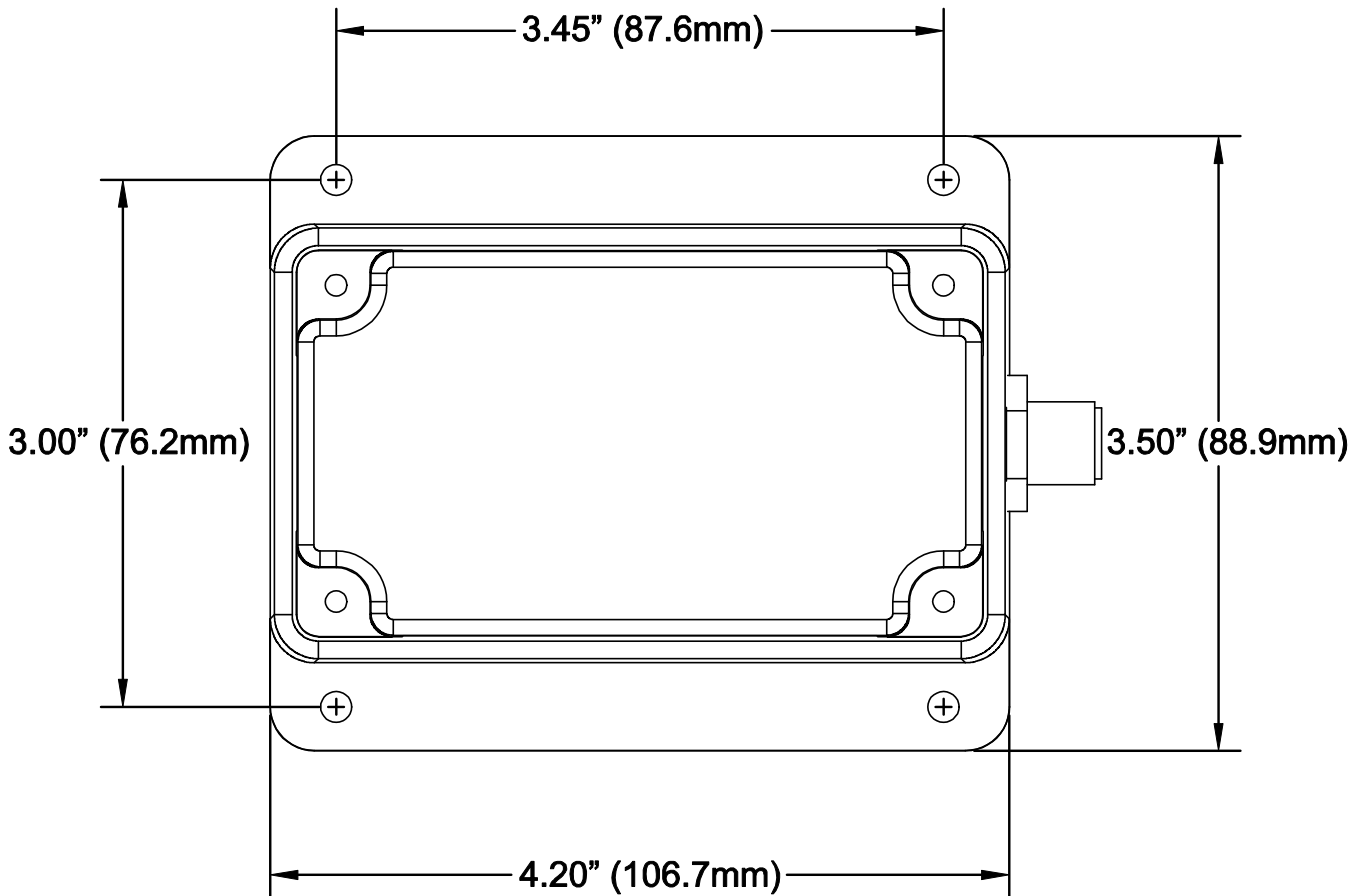

**Figure 5 – Mounting Surface Template**

### **8 Maretron (2 Year) Limited Warranty**

Maretron warrants the SIM100 to be free from defects in materials and workmanship for **two (2) years** from the date of original purchase. If within the applicable period any such products shall be proved to Maretron's satisfaction to fail to meet the above limited warranty, such products shall be repaired or replaced at Maretron's option. Purchaser's exclusive remedy and Maretron's sole obligation hereunder, provided product is returned pursuant to the return requirements below, shall be limited to the repair or replacement, at Maretron's option, of any product not meeting the above limited warranty and which is returned to Maretron; or if Maretron is unable to deliver a replacement that is free from defects in materials or workmanship, Purchaser's payment for such product will be refunded. Maretron assumes no liability whatsoever for expenses of removing any defective product or part or for installing the repaired product or part or a replacement therefore or for any loss or damage to equipment in connection with which Maretron's products or parts shall be used. With respect to products not manufactured by Maretron, Maretron's warranty obligation shall in all respects conform to and be limited to the warranty actually extended to Maretron by its supplier. The foregoing warranties shall not apply with respect to products subjected to negligence, misuse, misapplication, accident, damages by circumstances beyond Maretron's control, to improper installation, operation, maintenance, or storage, or to other than normal use or service.

THE FOREGOING WARRANTIES ARE EXPRESSLY IN LIEU OF AND EXCLUDES ALL OTHER EXPRESS OR IMPLIED WARRANTIES, INCLUDING BUT NOT LIMITED TO THE IMPLIED WARRANTIES OF MERCHANTABILITY AND OF FITNESS FOR A PARTICULAR PURPOSE.

Statements made by any person, including representatives of Maretron, which are inconsistent or in conflict with the terms of this Limited Warranty, shall not be binding upon Maretron unless reduced to writing and approved by an officer of Maretron.

IN NO CASE WILL MARETRON BE LIABLE FOR INCIDENTAL OR CONSEQUENTIAL DAMAGES, DAMAGES FOR LOSS OF USE, LOSS OF ANTICIPATED PROFITS OR SAVINGS, OR ANY OTHER LOSS INCURRED BECAUSE OF INTERRUPTION OF SERVICE. IN NO EVENT SHALL MARETRON'S AGGREGATE LIABILITY EXCEED THE PURCHASE PRICE OF THE PRODUCT(S) INVOLVED. MARETRON SHALL NOT BE SUBJECT TO ANY OTHER OBLIGATIONS OR LIABILITIES, WHETHER ARISING OUT OF BREACH OF CONTRACT OR WARRANTY, TORT (INCLUDING NEGLIGENCE), OR OTHER THEORIES OF LAW WITH RESPECT TO PRODUCTS SOLD OR SERVICES RENDERED BY MARETRON, OR ANY UNDERTAKINGS, ACTS OR OMISSIONS RELATING THERETO.

Maretron does not warrant that the functions contained in any software programs or products will meet purchaser's requirements or that the operation of the software programs or products will be uninterrupted or error free. Purchaser assumes responsibility for the selection of the software programs or products to achieve the intended results, and for the installation, use and results obtained from said programs or products. No specifications, samples, descriptions, or illustrations provided Maretron to Purchaser, whether directly, in trade literature, brochures or other documentation shall be construed as warranties of any kind, and any failure to conform with such specifications, samples, descriptions, or illustrations shall not constitute any breach of Maretron's limited warranty.

#### **Warranty Return Procedure:**

To apply for warranty claims, contact Maretron or one of its dealers to describe the problem and determine the appropriate course of action. If a return is necessary, place the product in its original packaging together with proof of purchase and send to an Authorized Maretron Service Location. You are responsible for all shipping and insurance charges. Maretron will return the replaced or repaired product with all shipping and handling prepaid except for requests requiring expedited shipping (i.e. overnight shipments). Failure to follow this warranty return procedure could result in the product's warranty becoming null and void.

Maretron reserves the right to modify or replace, at its sole discretion, without prior notification, the warranty listed above. To obtain a copy of the then current warranty policy, please go to the following web page:

<http://www.maretron.com/company/warranty.php>



## Appendix A – NMEA 2000® Interfacing

### SIM100 NMEA 2000® Periodic Data Transmitted PGNs

#### ***PGN 127501 – Binary Switch Bank Status***

The SIM100 uses this PGN to transmit the state of each of the connected switch inputs

- Field 1: Indicator Bank Instance – This field identifies the particular switch bank to which this PGN applies. Please refer to Section 2.5.1 for instructions on how to program the value of this field.
- 2: Indicator #1 – This field indicates the state of the switch connected to the SW1A and SW1B inputs of the SIM100. The state will be one of the following values:
- “Closed” – The monitored switch is closed.
  - “Open” – The monitored switch is open.
  - “Error” – There is an open connection between the SIM100 and the monitored switch. This state can occur only when the indicator is configured to use an End of Line Resistor.
  - “Data Not Available” – The indicator is configured as “Disabled”
- 3: Indicator #2 – This field indicates the state of the switch connected to the SW2A and SW2B inputs of the SIM100.
- 4: Indicator #3 – This field indicates the state of the switch connected to the SW3A and SW3B inputs of the SIM100.
- 5: Indicator #4 – This field indicates the state of the switch connected to the SW4A and SW4B inputs of the SIM100.
- 6: Indicator #5 – This field indicates the state of the switch connected to the SW5A and SW5B inputs of the SIM100.
- 7: Indicator #6 – This field indicates the state of the switch connected to the SW6A and SW6B inputs of the SIM100.