



# MODEL G5785 4" AIR ANGLE GRINDER INSTRUCTION SHEET





<b>⚠ WARNING</b>	
	<b>EYE/EAR INJURY HAZARD!</b> Wear safety glasses and hearing protection during use of this tool!
	<b>INJURY HAZARD!</b> Always disconnect tool from air to prevent unexpected operation during service!
	<b>EXPLOSION HAZARD!</b> Never exceed 120 PSI! Always use accessories with correct speed rating.
	<b>RESPIRATORY HAZARD!</b> Grinding produces fine dust. Wear the appropriate protection during use!



Figure 1. Model G5785.

Angle Grinder MUST have 3-4 drops of oil directly dropped into the air fitting before each use as shown in **Figure 2**.

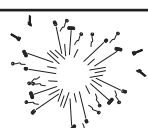
## Introduction

This 11,000 RPM Angle Grinder features a large paddle switch with safety mechanism and side handle for super control. G5785 has 5/8" arbor. Includes two wrenches. Weighs 5 lbs.

## Inventory

- A. 4" Air Angle Grinder ..... 1
- B. Handle ..... 1
- C. Flat Wrench ..... 1
- D. Pin Wrench ..... 1

## Operation

Tool requires 90 PSI and 1/4" NPT air fitting to operate correctly.

Make sure grinding wheel is backed by flange and tightened securely with the flange nut.

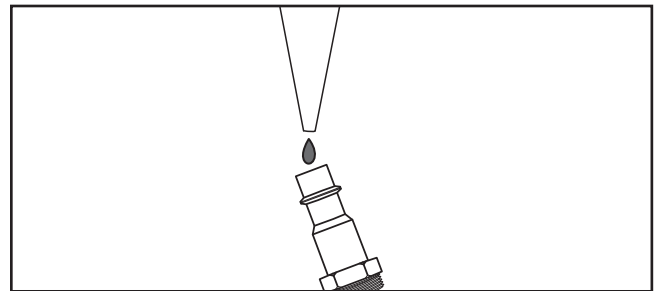

Figure 2. Lubricating directly into air fitting.

If you need help with your new pneumatic tool, call our Tech Support at: (570) 546-9663.

## Grinding Wheels

- Model G7381 ..... 4 x 1/8"
- Model G7382 ..... 4 x 1/4"

**Call 1-800-523-4777 To Order**

# G5785 Parts Breakdown and List

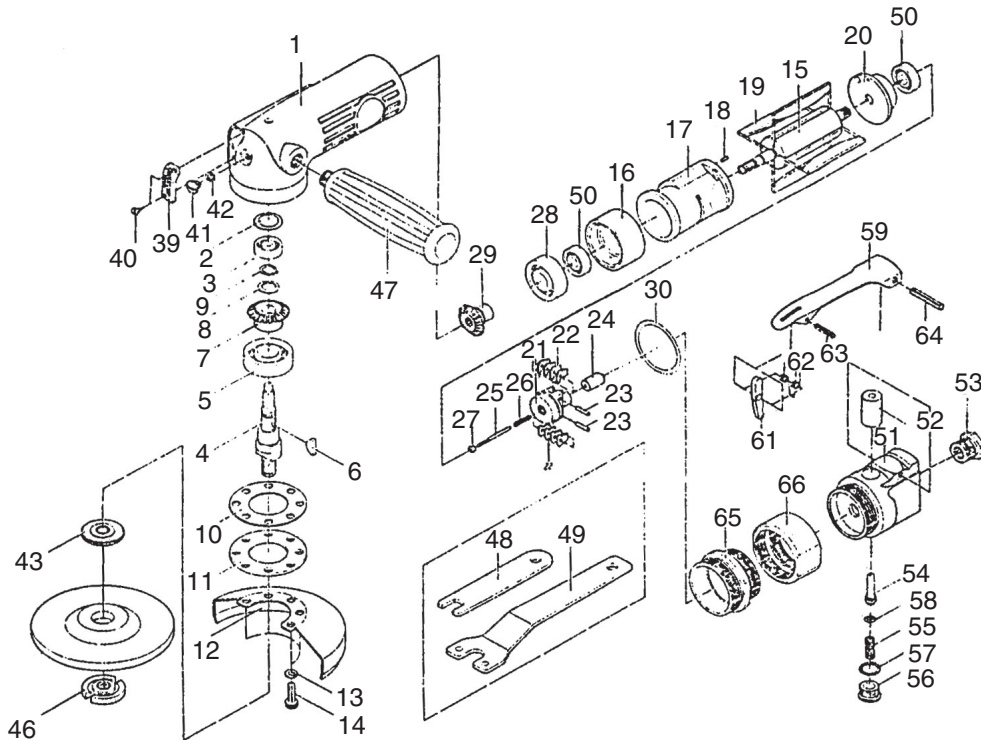

REF	PART #	DESCRIPTION
1	P5785001	MOTOR HOUSING
2	P5785002	SEAL PLATE
3	P5785003	BALL BEARING
4	P5785004	ARBOR
5	P5785005	BALL BEARING
6	P5785006	WOODRUFF KEY
7	P5785007	BEVEL GEAR
8	P5785008	WAVE WASHER
9	P5785009	EXTERNAL STOP RING
10	P5785010	GASKET
11	P5785011	RETAINER
12	P5785012	CENTER WHEEL GUARD
13	P5785013	SPRING WASHER
14	P5785014	HEX SOCKET HEAD CAP BOLT
15	P5785015	ROTOR
16	P5785016	FRONT END PLATE
17	P5785017	CYLINDER
18	P5785018	SPRING PIN
19	P5785019	ROTOR BLADE
20	P5785020	REAR END PLATE
21	P5785021	GOVERNOR
22	P5785022	PENDULUM
23	P5785023	SPRING PIN
24	P5785024	PLUNGER
25	P5785025	ADJUSTMENT SCREW
26	P5785026	SPRING
27	P5785027	ADJUSTMENT NUT
28	P5785028	BALL BEARING

REF	PART #	DESCRIPTION
29	P5785029	BEVEL PINION
30	P5785030	O-RING
39	P5785039	EXHAUST DEFLECTOR
40	P5785040	TAPPING SCREW
41	P5785041	PLUG
42	P5785042	O-RING
43	P5785043	FLANGE
46	P5785046	NUT
47	P5785047	HANDLE
48	P5785048	FLAT WRENCH
49	P5785049	PIN WRENCH
50	P5785050	BALL BEARING
51	P5785051	THROTTLE VALVE HSG
52	P5785052	BUSHING
53	P5785053	AIR INLET BUSHING
54	P5785054	VALVE STEM
55	P5785055	VALVE SPRING
56	P5785056	CAP
57	P5785057	O-RING
58	P5785058	O-RING
59	P5785059	THROTTLE LEVER
61	P5785061	THROTTLE LEVER LOCK
62	P5785062	TORSION SPRING
63	P5785063	SPRING PIN
64	P5785064	SPRING PIN
65	P5785065	LOCK RING
66	P5785066	COUPLING NUT