

INSTALLATION INSTRUCTIONS

ENGINE WINTERIZING KIT
MFG. NO. 1690565

FOR USE ON 10 H.P. TO
17 H.P. HORIZONTAL SHAFT
BRIGGS & STRATTON ENGINES

NOTE

In these instructions, "later models" refers to tractors with the following manufacturer's numbers:

1690472, 1690473, 1690474, 1690475, 1690476,
1690477, 1690478, 1690479, 1690480, 1690515,
1690516, 1690517, 1690518, 1690519 or 1690538.

"Early model" refers to all other tractors.

WARNING

For your personal safety, stop tractor engine and remove ignition key before working on unit. Set the parking brake.

KIT PARTS

| Qty. | Name |
|------|---|
| 1 | Deflector |
| 2 | Spacer (Used on Later Models Only) |
| 2 | Capscrew, 1/4-20 x 1 |
| 2 | Lockwasher, 1/4 |
| 2 | Nut, 1/4-20 |
| 1 | Template (Used on Later Models Only) |
| 1 | Carburetor Shield (Used on Early Models Only) |

MOUNTING DEFLECTOR ON EARLY MODEL TRACTORS

There are three possible variations in mounting the deflector. Install the deflector as described in either step 1, 2 or 3.

1. If the tractor has side mounted headlights, use hardware that secures the left headlight to the hood. The hardware sent with kit is not needed. The deflector will be positioned as shown in figure 1 (headlight not shown).
2. If the tractor does not have side mounted headlight, but has mounting holes, install the deflector as shown in figure 1. Use the two capscrews, lockwashers and nuts from kit. Install capscrews from outside. The two spacers sent with kit are not needed.

3. If the tractor has neither side mounted headlights or mounting holes, two 5/16" holes must be drilled. To drill the holes and install the deflector, proceed as follows.
 - a. Open the hood. Place the deflector in position as shown in figure 1. Make sure clip on top edge of deflector fully engages the hood. Slide deflector as far as possible toward front of tractor. Mark position of mounting holes and remove the deflector.
 - b. Drill 5/16" holes where marked.
 - c. Mount deflector using the two capscrews, lockwashers and nuts. Install capscrews from outside, with lockwashers and nuts inside against the deflector.

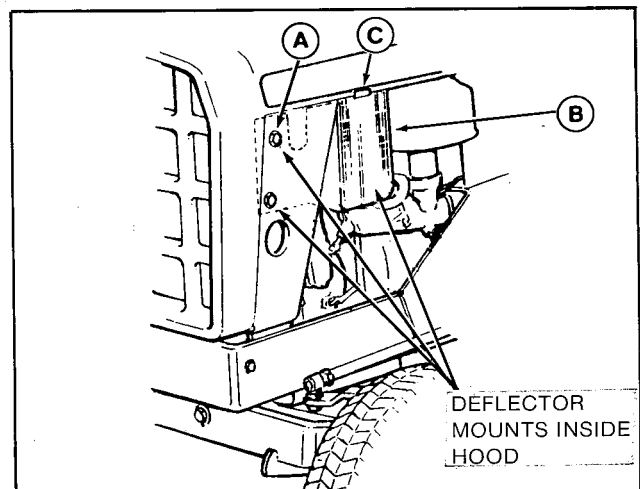

- A. Capscrew, Lockwasher & Nut
B. Deflector
C. Clip

Figure 1. Deflector Installed, Early Model Tractor

MOUNTING DEFLECTOR ON LATER MODEL TRACTORS

1. Position the template on the left side of the hood as shown in figure 2. Mark the positions of the two new holes with a punch and remove the template. Drill two 5/16" holes.

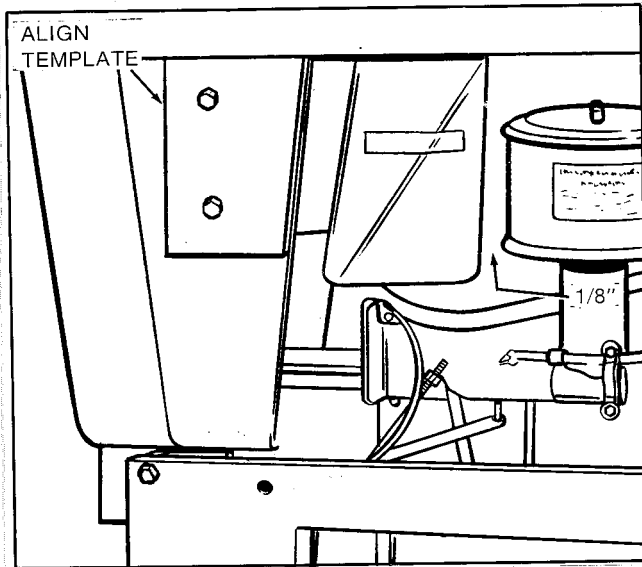

**Figure 2. Aligning Template (Later Model Tractor)
(Shown with Deflector Installed)**

2. Install the deflector as shown in figure 3. Install the capscrews from the outside. The two spacers are between hood and deflector. Notice that the clip on top of the deflector does not engage the hood. Close the hood. There should be about 1/8" clearance between edge of deflector and air cleaner as shown in figure 2.

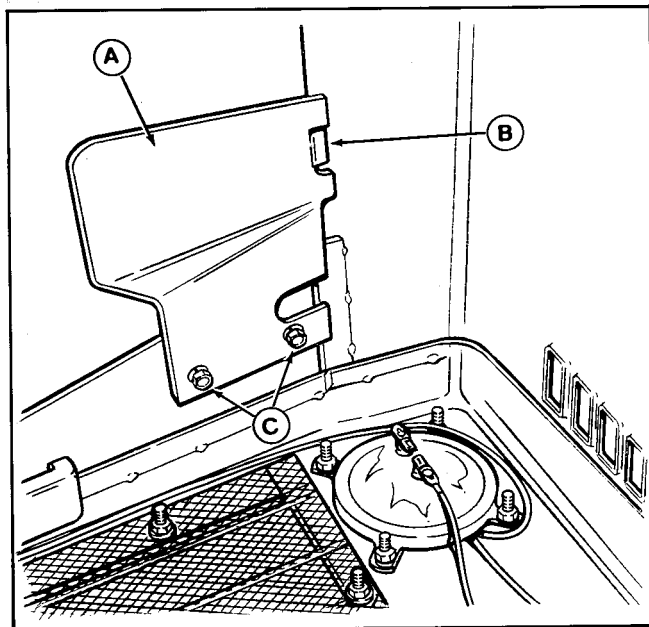

- A. Deflector
- B. Clip
- C. Lockwasher & Nut

Figure 3. Deflector Installed (Later Model Only)

INSTALLING CARBURETOR SHIELD ON EARLY MODEL TRACTORS

The carburetor shield is shown in figure 4.

1. Remove the air cleaner.
2. Loosen the two screws shown in figure 5 which mount the carburetor to the intake manifold.

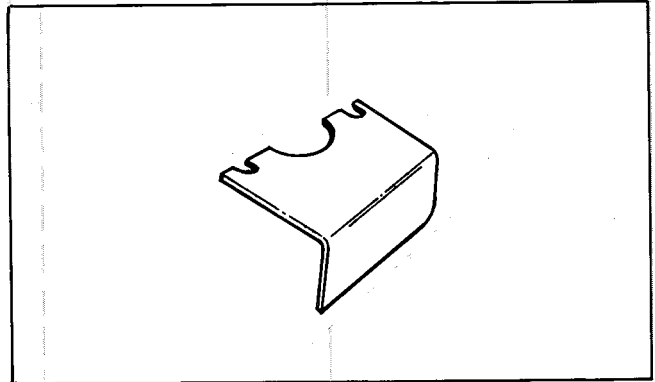

Figure 4. Carburetor Shield (Early Models Only)

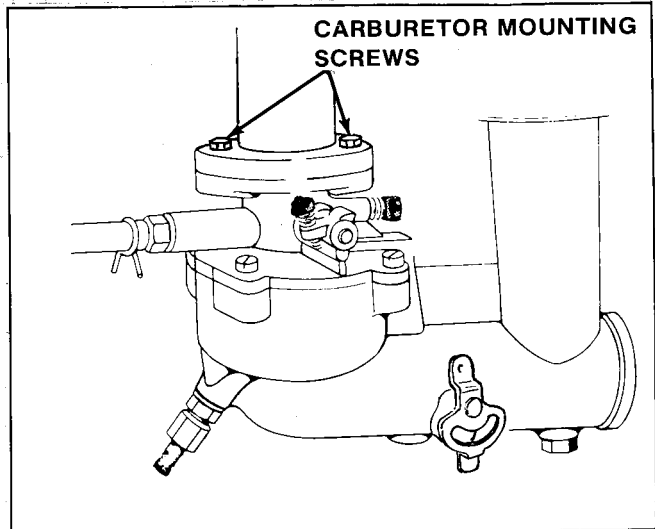

Figure 5. Shield Mounting Screws (Early Models Only)

3. Slide the carburetor shield in place, above the manifold flange, with the slots underneath the screw heads and lockwashers.
4. Tighten the two mounting screws to hold both carburetor and shield to manifold.



CAUTION

This kit is for winter use only. Remove for summer operation.

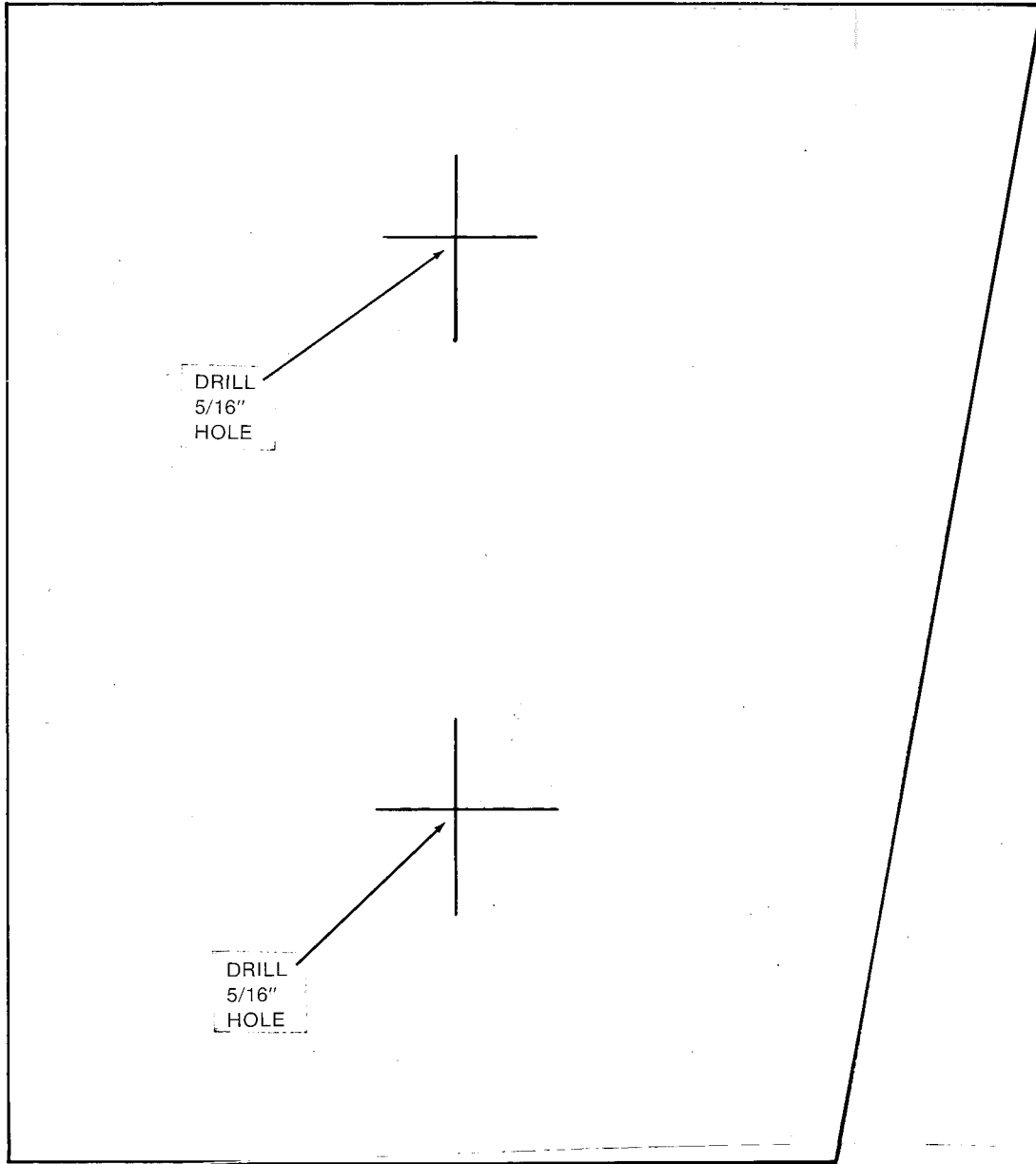

TEMPLATE FOR LATER MODELS ONLY

Kit No. 1690565
Instruction Sheet 1667176