

TOSHIBA



Color Television

32AX60/36AX60

Owner's Manual

Welcome to
Toshiba

Connecting
your TV

Using the
Remote Control

Setting up
your TV

Using the TV's
Features

Appendix

Index

SAFETY PRECAUTIONS

WARNING

TO REDUCE THE RISK OF FIRE OR ELECTRIC SHOCK, DO NOT EXPOSE THIS APPLIANCE TO RAIN OR MOISTURE.



The lightning symbol in the triangle tells you that the voltage inside this product may be strong enough to cause an electric shock. DO NOT TRY TO SERVICE THIS PRODUCT YOURSELF.



The exclamation mark in the triangle tells you that important operating and maintenance instructions follow this symbol.

CAUTIONS

TO PREVENT ELECTRIC SHOCK, DO NOT USE THIS POLARIZED PLUG WITH AN EXTENSION CORD RECEPTACLE OR OTHER OUTLET UNLESS THE PRONGS CAN BE FULLY INSERTED INTO THE OUTLET TO PREVENT ANY EXPOSURE OF THE PRONGS ON THE POLARIZED PLUG.

PRECAUCIONES

PARA EVITAR DESCARGAS ELÉCTRICAS, NO UTILICE ESTE ENCHUFE POLARIZADO CON UN RECEPTÁCULO DE CABLE DE EXTENSIÓN U OTRA TOMA SALVO QUE LA CLAVIJA ESTÉ COMPLETAMENTE INSERTADA EN LA TOMA PARA EVITAR CUALQUIER EXPOSICIÓN DE LOS VÁSTAGOS DEL ENCHUFE POLARIZADO.

WARNING

To avoid personal injury:

- Do not stand or climb on the TV.
- Do not put a VCR or any heavy object on top of the TV.

ADVERTENCIA

Para evitar daños personales:

- No se ponga de pie en el TV ni suba a él.
- No coloque el video (p. ej. VCR) ni otro objeto pesado en la parte superior del TV.

Avoid displaying stationary images on your TV screen for extended periods of time. Stationary patterns generated by a picture-in-picture (PIP) display, computer displays, video games, stock market reports, etc., can become permanently engrained on the picture tube. This damage is not protected by your warranty because it is the result of misuse. If you wish to use your TV to display still images, reduce brightness and contrast settings. Never leave a PIP, computer, or video game display unattended.

This TV set should be used with the Toshiba stand listed on page 33. Use with other stands may result in instability, causing possible injury.

Note to CATV system installers in the USA

This reminder is provided to call the CATV system installer's attention to Article 820-40 of the NEC, which provides guidelines for proper grounding, and, in particular, specifies that the cable ground shall be connected to the grounding system of the building, as close to the point of cable entry as practical.

IMPORTANT SAFETY INSTRUCTIONS

INSTRUCCIONES DE SEGURIDAD

CAUTION

PLEASE READ AND OBSERVE ALL WARNINGS AND INSTRUCTIONS CONTAINED IN THIS SECTION AND THOSE ON YOUR TV SET.

RETAIN THIS SECTION FOR REFERENCE.

PRECAUCIÓN

LEA Y TENGA EN CUENTA TODAS LAS ADVERTENCIAS E INSTRUCCIONES QUE SE ENCUENTRAN EN ESTE PANFLETO Y LAS DE LOS APARATOS DE TELEVISIÓN.

MANTENGA ESTE PANFLETO PARA FUTURAS REFERENCIAS.

Electrical energy can perform many useful functions. This TV set has been engineered and manufactured to assure your personal safety. However, improper use can result in potential electrical shock or fire hazards. In order not to defeat the safeguards incorporated in this TV set, observe the following basic rules for antenna/TV installation, use and servicing.

Do not remove the cabinet cover. This may expose you to dangerous voltages. Refer all servicing to qualified service personnel.

La energía eléctrica puede realizar funciones muy útiles. Este televisor ha sido diseñado y fabricado para asegurar su seguridad personal. Sin embargo, la utilización inadecuada del mismo puede resultar en descargas eléctricas o en el riesgo de incendios. Para no anular las protecciones incorporadas en este televisor, tenga en cuenta las reglas básicas de instalación de la antena/televisor, y en caso de problemas póngase en contacto con un centro de reparaciones.

No extraiga de la cubierta de la caja. Esto podría dejarle expuesto a tensiones peligrosas. En caso de avería, consulte los servicios de personal cualificado.

INSTALLATION / INSTALACIÓN

Power Sources — The TV set should be operated only from the type of power source indicated on the TV set or as indicated in the Owner's Manual. If you are not sure of the type of power supply in your home, consult your sales person or your local power company. For TV sets designed to operate from battery power, refer to the operating instructions.

Fuentes de alimentación — Este televisor solamente deberá alimentarse con la fuente de alimentación indicada en la etiqueta de características. Si no está seguro del tipo de fuente de alimentación de su hogar, consulte al proveedor de su televisor o a la compañía eléctrica local. Para productos destinados a alimentarse con pilas, u otras fuentes, consulte las instrucciones de operación.

Grounding or Polarization — The TV set is equipped with one of the following type plugs. If the plug should fail to fit the power outlet, contact your electrician to replace your obsolete outlet. DO NOT defeat the safety purpose of the type plug on the TV set.

Puesta a tierra o polarización — Este televisor puede poseer un enchufe de los tipos siguientes. Si el enchufe no entra en la toma de la red, póngase en contacto con un electricista para que le cambie la toma anticuada. NO anule el fin de seguridad de este tipo de enchufe del televisor.

A polarized alternating current line plug — having one blade wider than the other. This plug will fit into the power outlet only one way. If you are unable to insert the plug into the outlet, try reversing the plug.

Un enchufe de línea de corriente alterna polarizado — posee una cuchilla más ancha que la otra. Este enchufe entrará en la toma de la red de una sola forma. Si no puede insertar el enchufe en la toma de la red, trate de invertirlo.

Alternate Warnings — A three-wire grounding-type plug — a plug having a third (grounding) pin. This plug will only fit into grounding-type power outlet.

Advertencias alternativas — Enchufe de tipo puesta a tierra de tres conductores — enchufe que posee un tercer terminal (de puesta a tierra). Este enchufe solamente encajará en una toma de la red de tipo puesta a tierra.

Water and Moisture — Do not use the TV set near water — for example, near a bath tub, wash bowl, kitchen sink, or laundry tub; in a wet basement; or near a swimming pool; and the like.

Agua y humedad — No utilice el televisor cerca del agua — por ejemplo, cerca de una bañera, un lavabo, un fregadero, una lavadora, en un sótano húmedo, cerca de una piscina, ni lugares por el estilo.

Ventilation — The slots and openings in the cabinet and in the back or bottom are provided for necessary ventilation. Never block or cover these slots and openings to ensure reliable operation of the TV set and to protect it from overheating.

Ventilación — Las ranuras y aberturas de la caja y de la parte posterior o de la base son para proporcionar la ventilación necesaria. Para asegurar la operación fiable del televisor para protegerlo contra el recalentamiento. No bloquee ni cubra nunca estas ranuras y aberturas.

- Never cover the slots and openings with a cloth or other materials.
- No cubra nunca las ranuras ni las aberturas con paños ni otros materiales.
- Never block the slots and openings by placing the TV set on a bed, sofa, rug or other similar surface.
- No bloquee nunca las ranuras ni las aberturas colocando el televisor sobre una cama, un sofá, una alfombra, ni demás superficies similares.
- Never place the TV set in a confined space such as a bookcase, built-in cabinet, or any other place of poor ventilation.
- No coloque nunca el televisor en un espacio cubierto, como una librería o un estante empotrados, ni en un lugar de mala ventilación.

Heat — Do not place the TV set near or over a radiator or heat register, or where it is exposed to direct sunlight.

Calor — No coloque el televisor cerca ni sobre un radiador ni un registro de calor, ni expuesto a la luz solar directa.

Power-Cord Protection — Do not allow anything to rest on or roll over the power cord, and do not place the TV set where the power cord is subject to wear or abuse.

Protección del cable de alimentación — No coloque ni pase sobre el cable de alimentación, ni coloque el televisor donde su cable de alimentación pueda sufrir cualquier tipo de daños.

Accessories — Do not place the TV set on an unstable cart, stand, tripod, bracket, or table. The TV set may fall, causing serious injury to a child or adult, and serious damage to the TV set. Use only with a cart, stand, tripod, bracket, or table recommended by the manufacturer, or sold with the TV set, and should use a mounting accessory recommended by the manufacturer.

Accesorios — No coloque el televisor sobre un carrito, una base, un trípode, un soporte ni una mesa inestable. El televisor podría caerse, causando serios daños a niños o adultos, o al propio televisor. Utilice solamente el carrito, la base, el trípode, el soporte, o la mesa que recomiende el fabricante, o que se venda con el televisor, y utilice un accesorio de montaje recomendado por el fabricante.

A product and cart combination should be moved with care. Quick stops, excessive force, and uneven surfaces may cause the product and cart combination to overturn.

La combinación de un producto y un carrito deberá moverse con cuidado. Las paradas repentinas, la fuerza excesiva, y las superficies desiguales pondrían hacer que volcase la combinación del carrito y del producto.



USE / UTILIZACIÓN

Overloading — Do not overload wall outlets, extension cords or convenience receptacles beyond their capacity, since this can result in fire or electric shock.

Sobrecarga — No sobrecargue las tomas de la red, los cables prolongadores, ni los adaptadores para múltiples tomas, ya que esto supondría el riesgo de incendios o de descargas eléctricas.

During lightning storms, or when the TV set will be left unattended and unused for a long period of time, unplug the power cord from the wall outlet and disconnect the antenna or cable system. This will prevent damage to the TV set due to lightning and power-line surges.

Durante tormentas eléctricas, o cuando no vaya a utilizar el televisor durante mucho tiempo, desenchufe el cable de alimentación de la toma de la red y desconecte la antena o el sistema de cablevisión. Esto evitará que se dañe el televisor debido a rayos y a sobretensiones repentinas en la red.

Object and Liquid Entry — Never push objects of any kind into the TV set through the cabinet slots as they may touch dangerous voltage points or short out parts that could result in a fire or electric shock. Never spill liquid of any kind on the TV set.

Entrada de objetos y líquidos — No introduzca nunca objetos de ningún tipo en este televisor a través de las aberturas, ya que podrían tocar puntos de tensión peligrosa o cortocircuitar piezas, lo que podría resultar en incendio o descarga eléctrica. No vierta nunca líquidos de ningún tipo sobre este televisor.

Cleaning — Unplug the TV set from the wall outlet before cleaning or polishing it. Do not use liquid cleaners or aerosol cleaners. Use a cloth lightly dampened with water for cleaning the exterior of the TV set.

Limpieza — Desenchufe el televisor de la toma de la red antes de limpiarlo. No utilice limpiadores líquidos ni aerosoles. Para limpiar el exterior del televisor, utilice un paño ligeramente humedecido en agua.

Attachments — Never add accessories that have not been specifically designed for the TV set. Never remodel the TV set by yourself as this can result in a fire hazard or electric shock.

Aditamentos — No utilice aditamentos no recomendados por el fabricante del televisor, ya que podrían suponer un peligro. No remodele nunca el televisor usted mismo, ya que esto podría causar el riesgo de incendios o descargas eléctricas.

If a snapping or popping sound from a TV set is heard continuously or frequently while the TV set is operated, unplug the TV set and consult your dealer or service technician. It is normal for some TV sets to make occasional snapping or popping sounds, particularly when being turned on or off.

Si se oye un sonido seco de un televisor continuo o frecuente mientras el televisor esté funcionando, desenchúfelo y consulte a su proveedor o a un técnico de servicio. Es normal que algunos televisores produzcan sonidos secos, particularmente cuando conecte o desconecte su alimentación.

SERVICE / SERVICIO DE REPARACIÓN

Damage Requiring Service — Unplug the TV set from the wall outlet and refer servicing to qualified service personnel under the following conditions:

Daños que requieren el servicio de reparación — En los casos siguientes, desenchufe el televisor de la toma de la red y solicite los servicios de personal de reparación especializado:

- a. When the power cord or plug is damaged or frayed.
a. Cuando se haya dañado el cable de alimentación o el enchufe.
- b. When liquid has been spilled into the TV set.
b. Cuando se haya vertido líquido dentro del televisor.
- c. When the TV set has been exposed to rain or water.
c. Cuando el televisor haya estado expuesto a la lluvia o al agua.
- d. When the TV set has been subject to excessive shock by being dropped, or the cabinet has been damaged.
d. Cuando el televisor haya estado expuesto a golpes excesivos o haya caído, o su caja se haya dañado.
- e. When the TV set does not operate normally even though you follow the operating instructions. Adjust only those controls that are specified in the operating instructions. Improper adjustment of other controls may result in damage and will often require extensive work by a qualified technician to restore the TV set to normal operation.

When the TV set exhibits a distinct change in performance. This indicates a need for service.

- e. Cuando el televisor no funcione normalmente incluso al seguir las instrucciones de operación. Ajuste solamente los controles indicados en las instrucciones de operación, ya que un ajuste inadecuado de otros controles podría resultar en daños y a menudo requerirán un trabajo difícil por un técnico cualificado para devolver el televisor a su funcionamiento normal.

Cuando el funcionamiento del televisor haya cambiado notablemente — esto indica la necesidad del servicio de reparación.

Servicing — Do not attempt to service the TV set yourself. To open or remove the covers may expose you to dangerous voltage or other hazards. Refer all servicing to qualified service personnel.

Reparación — No intente nunca reparar el televisor por sí mismo. La apertura o extracción de cubiertas podría exponerle a tensiones peligrosas u otros peligros. En caso de avería solicite los servicios de personal de reparación cualificado.

Replacement Parts — When replacement parts are required, be sure the service technician certifies in writing that he has used replacement parts specified by the manufacturer that have the same characteristics as the original parts. Unauthorized substitutions may result in fire, electric shock, or other hazards.

Reemplazo de piezas — Cuando sea necesario reemplazar piezas, cerciórese de que el técnico de reparación utilice las piezas de reemplazo especificadas por el fabricante u otras que posean las mismas características que las originales. Las substituciones no autorizadas podrían resultar en incendios, descargas eléctricas, u otros peligros.

Safety Check — Upon completion of any service or repairs to the TV set, ask the service technician to perform routine safety checks (as specified by the manufacturer) to determine that the TV set is in safe operating condition, and to so certify.

Comprobación de seguridad — Al finalizar cualquier reparación de este televisor, solicite al técnico de reparación que realice las comprobaciones de seguridad (especificadas por el fabricante) para determinar y certificar si el producto se encuentra en las condiciones de operación apropiadas.

When the TV set reaches the end of its useful life, improper disposal could result in a picture tube implosion. Ask a qualified service technician to dispose of the TV set.

Cuando el televisor llegue al final de su vida útil, si se deshace de él de forma inapropiada, el tubo de imagen puede explotar. Cuando desee deshacerse de un televisor, solicite este servicio a un técnico de reparación especializado.

ANTENNA / ANTENA

Outdoor Antenna Grounding — If an outdoor antenna is installed, follow the precautions below.

An outdoor antenna system should not be located in the vicinity of overhead power lines or other electric light or power circuits, or where it can come in contact with such power lines or circuits.

WHEN INSTALLING AN OUTDOOR ANTENNA SYSTEM, EXTREME CARE SHOULD BE TAKEN TO KEEP FROM CONTACTING SUCH POWER LINES OR CIRCUITS AS CONTACT WITH THEM IS ALMOST INVARIABLY FATAL.

Be sure the antenna system is grounded so as to provide some protection against voltage surges and built-up static charges. Section 810 of the National Electrical Code in the USA and Section 54 of the Canadian Electrical Code in Canada provides information with respect to proper grounding of the mast and supporting structure, grounding of the lead-in wire to an antenna discharge unit, size of grounding conductors, location of antenna discharge unit, connection to grounding electrodes, and requirements for the grounding electrode.

Puesta a tierra de la antena exterior — Cuando instale una antena exterior, tenga en cuenta las precauciones siguientes.

Un sistema de antena exterior no deberá colocarse cerca de líneas de alta tensión ni otros circuitos de iluminación o alimentación, ni donde pueda entrar en contacto con tales líneas o circuitos.

CUANDO INSTALE UN SISTEMA DE ANTENA EXTERIOR, TENGA EXTREMADO CUIDADO PARA EVITAR QUE ENTRE EN CONTACTO CON TALES LÍNEAS DE ALIMENTACIÓN O CIRCUITOS, YA QUE TAL CONTACTO PODRÍA RESULTAR INVARIABLEMENTE FATAL.

Cerciórese de que el sistema de antena esté puesto a tierra a fin de que proporcione cierta protección contra sobretensiones y cargas estáticas. La Sección 810 del Código Eléctrico Nacional (NEC) de EE.UU. y la Sección 54 del Código Eléctrico Canadiense ofrecen información con respecto a la puesta a tierra adecuada de una unidad de descarga de antena, el tamaño de los conductores de puesta a tierra, la ubicación de la unidad de descarga de la antena, la conexión de los electrodos de puesta a tierra, y los requisitos de tales electrodos.

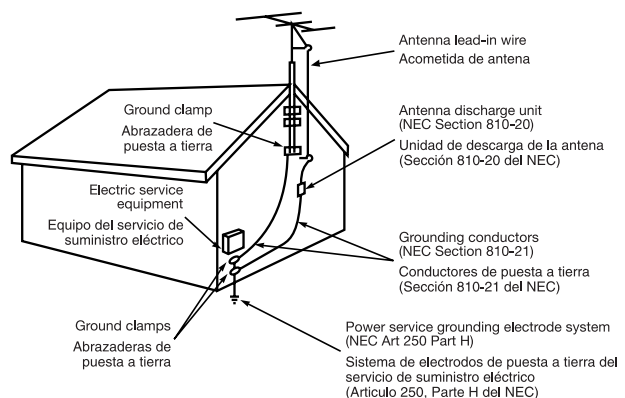

Welcome to Toshiba	1
Exploring your new TV	1
Selecting a location for the TV	1
Connecting your TV	2
Connecting a VCR.....	2
Connecting a cable converter box.....	3
Connecting a cable converter box and VCR	3
Connecting a DVD/satellite receiver and VCR	4
Connecting a DVD with ColorStream™ and a VCR	4
Connecting two VCRs	5
Connecting a camcorder	6
Connecting an audio amplifier	6
Using the remote control	7
Preparing the remote control for use	7
Installing the remote control batteries	7
Using the remote control with a VCR or cable TV converter	7
Programming the remote control for use with a VCR or cable TV converter	8
VCR code table	8
Cable TV converter code table	9
Learning about the remote control	10
Setting up your TV	11
Changing the on-screen display language	11
Selecting the antenna input	11
Using the TV/VIDEO button on the TV	12
Adding channels to the TV's memory	12
Programming channels automatically	12
Adding and erasing channels manually	13
Changing channels	13
Using the TV's features	13
Adjusting the channel settings	13
Switching between two channels	13
Programming your favorite channels	14
Using the V-Chip	15
Selecting a PIN code	15
Blocking programs by ratings	17
Ratings definitions (MPAA, Youth TV, TV)	17
Blocking unrated movies and programs	19
Blocking channels	20

Video Lock	21
Channel labels	22
Video labels	23
Watching picture-in-picture (PIP)	24
Switching the main and small pictures	24
Changing the position of the small picture	25
Freezing the small picture	25
Watching multi-window PIP	25
Adjusting the picture	26
Adjusting the picture quality	26
Selecting the color temperature	26
Adjusting the picture preference	27
Watching video input	27
Displaying on-screen information	27
Setting the off-timer	27
Auto power off	27
Using the closed caption feature	28
Adjusting the sound	29
Muting the sound	29
Selecting stereo/SAP broadcasts	29
Adjusting the sound quality	30
Using the surround sound feature	30
Using the sub-bass system (SBS)	31
Viewing the demonstration (DEMO) mode	31
Understanding the last mode memory feature	31
Appendix	32
Cleaning and care	32
Troubleshooting	32
Specifications	33
Limited United States warranty	34
Attention Canadian customers	35
Index	36

Welcome to Toshiba

Congratulations! You have purchased one of the finest color TVs on the market. The goal of this manual is to guide you through setting up and operating your Toshiba TV as quickly as possible. Please make sure you have received the following items: TV, remote control, batteries, manual, registration card, and extended service plan literature. If you did not receive all of the items or if any of the items are damaged or broken, please contact your Toshiba dealer. In addition, you may need to purchase other audio or video cables to connect your equipment. See "Connecting your TV" on page 2 for more information.

Please read all safety and operating instructions carefully before you begin.

Exploring your new TV

You can operate your TV using the buttons on the front panel or the remote control. The back panel provides all the terminal connections you will need to connect other equipment to your TV.

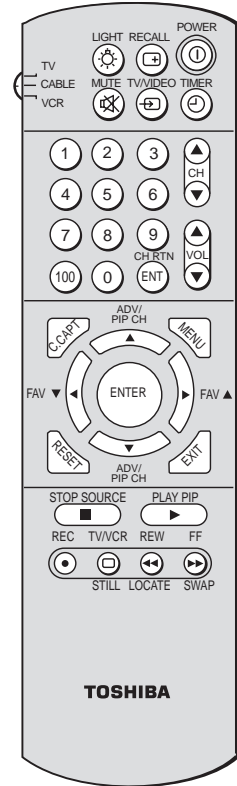
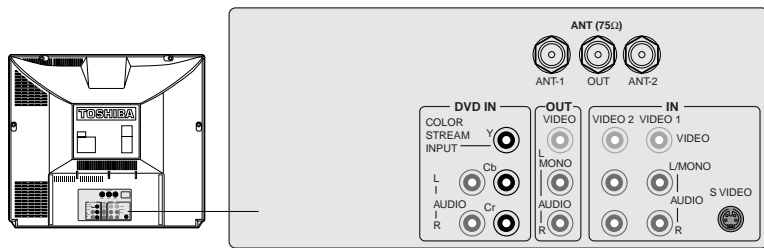
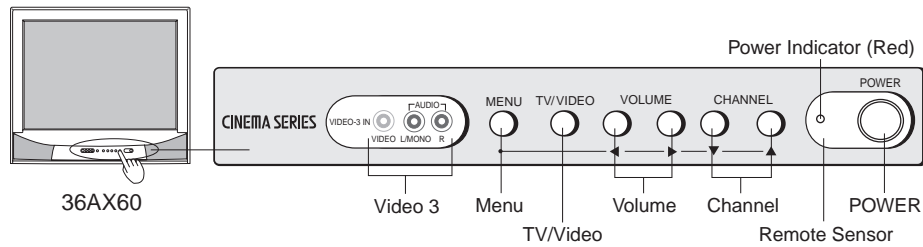
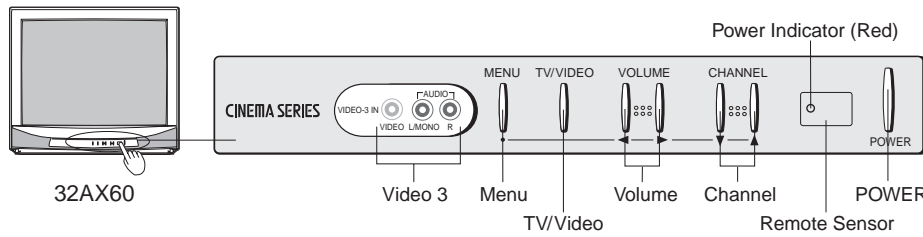

Selecting a location for the TV

- Place the TV on the floor or on a sturdy platform in a location where light does not directly hit the screen.
- Place the TV far enough from the walls to allow proper ventilation. Inadequate ventilation may cause overheating, which may damage the TV.

The model number and serial number are on the back of your TV. Record these numbers in the spaces below. Refer to these numbers whenever you communicate with your Toshiba dealer about this TV.

Model number: _____

Serial number: _____

Caution:

The plug has one prong wider than the other and will fit only one way into a standard electrical outlet (120 volt AC, 60 Hz). If the plug does not fit into the outlet, try turning it around. If the plug still does not fit, the outlet is probably non-standard and must be replaced by a qualified electrician. **Do not tamper with the plug or try to force it into a non-standard outlet.**

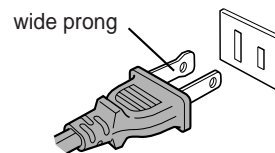

Connecting your TV

If you have not connected electronic equipment before, or you have been frustrated in the past, you may wish to read this section.

Note: Cables are not supplied.

- A coaxial cable is the standard cable that comes in from your antenna or cable converter box. Coaxial cables use “F” connectors.
- Audio and video cables are usually color coded according to use: yellow for video; red and white for audio. The red audio cable is for the stereo right channel; the white audio cable is for the stereo (or mono) left channel. If you look at the rear panel of the TV, you will see that the terminals are color coded in the same manner as the cables.
- S-video cables provide better picture performance. S-video cables can be used only with S-video compatible components.
- ColorStream™ cables come in sets of three and provide the best picture performance. ColorStream cables can be used only with ColorStream compatible components.

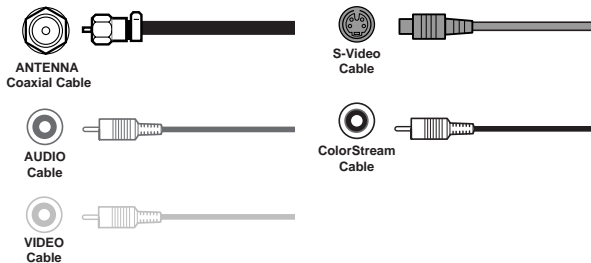

Caution:

Do not plug in the TV power cord until you have finished connecting all of your equipment.

Connecting a VCR

This connection allows you to watch local channels and video programs, play or record on the VCR while watching TV, and record from one channel while watching another channel.

You will need:

- one coaxial cable
- one pair of audio cables (only one cable for a mono VCR)
- one video cable

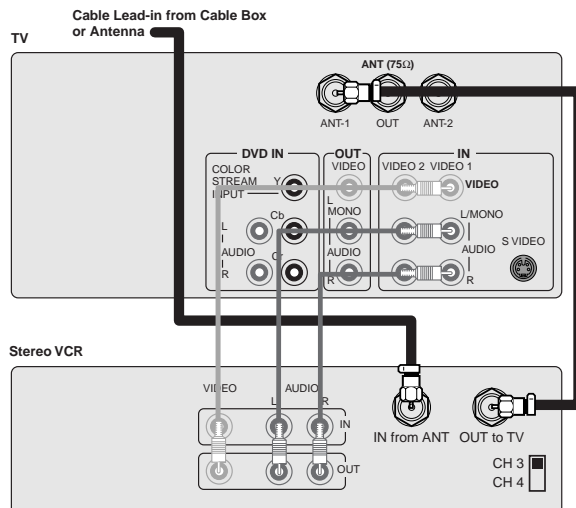

Caution:

If you have a mono VCR, connect L/Mono to VCR Audio OUT using only one audio cable.

If you have an S-VHS VCR, use the S-video connections and omit the video cable.

Do not connect the video cable and the S-video cable to Video-1 simultaneously.

Connecting a cable converter box

This connection allows you to watch cable and premium channels. To use the TV features (such as PIP swap, Channel ▲▼, channel block, favorite channels, or channel labels), select ANT-1. To view premium channels, select ANT-2, tune the TV to channel 3 or 4 (whichever channel is vacant in your area), and use the converter box to change channels.

You will need:

- two coaxial cables

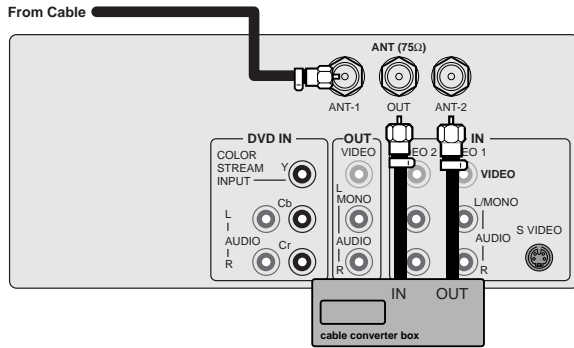

Note:

When you use a converter box with your TV, there may be features you will not be able to program using the remote control, such as PIP swap, Channel ▲▼, channel block, favorite channels, or channel labels.

Connecting a cable converter box and VCR

This connection allows you to watch and record basic and premium cable channels, as well as watch videotapes. Change the TV to Video mode. Tune the VCR to channel 3 or 4 (the same channel as the converter box output switch). Use the cable converter box to change channels. Set the PIP source to TV mode (see page 24).

You will need:

- three coaxial cables
- one pair of audio cables (one single cable for a mono VCR)
- one video cable
- one cable splitter

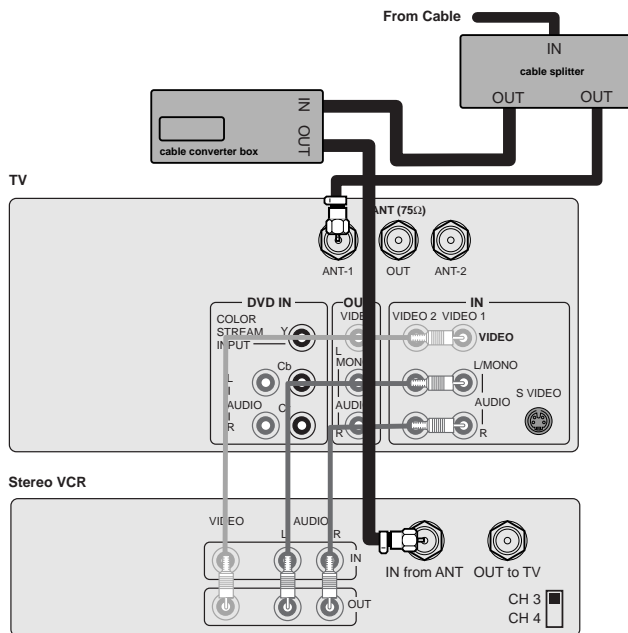

Note:

If you have a mono VCR, connect L/Mono to VCR Audio OUT using only one audio cable.

If you have an S-VHS VCR, use the S-video connections and omit the video cable.

Caution:

Do not connect the video cable and the S-video cable to Video-1 simultaneously.

Connecting a DVD/satellite receiver and VCR

This connection allows you to watch DVD/satellite, video, or TV programs. You can record from the DVD/satellite receiver and TV, as well as record one TV channel while watching another channel.

You will need:

- one coaxial cable
- three pairs of audio cables (one pair and two single cables for a mono VCR)
- two video cables
- one S-video cable

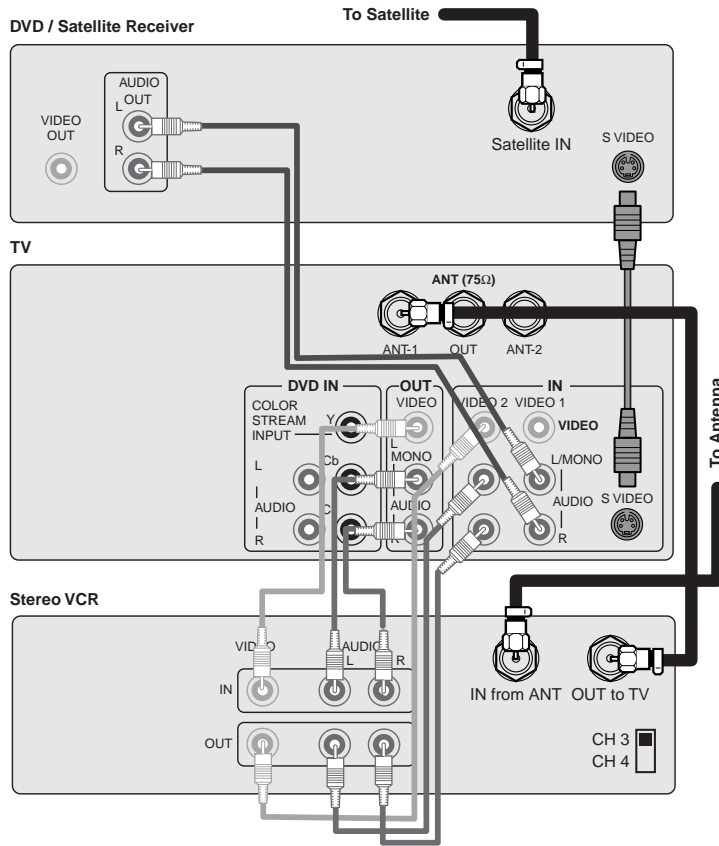

Note:

You can use a video cable instead of the S-video cable, but the picture quality will decrease.

If you use an S-video cable between the TV and DVD/satellite receiver, make the audio connections only and omit the video connection.

Caution:

Do not connect the video cable and the S-video cable to Video-1 simultaneously.

Connecting a DVD with ColorStream™ and a VCR

This connection allows you to watch DVD, video, or TV programs, and record DVD or TV programs. You can record from one source and watch a program from another source. Your TV is capable of using ColorStream (color difference). Connecting your TV to a ColorStream compatible DVD, such as a Toshiba DVD, can greatly enhance picture quality and performance.

You will need:

- one coaxial cable
- three pairs of audio cables (one pair and two single cables for a mono VCR)
- two video cables
- one set of ColorStream video cables

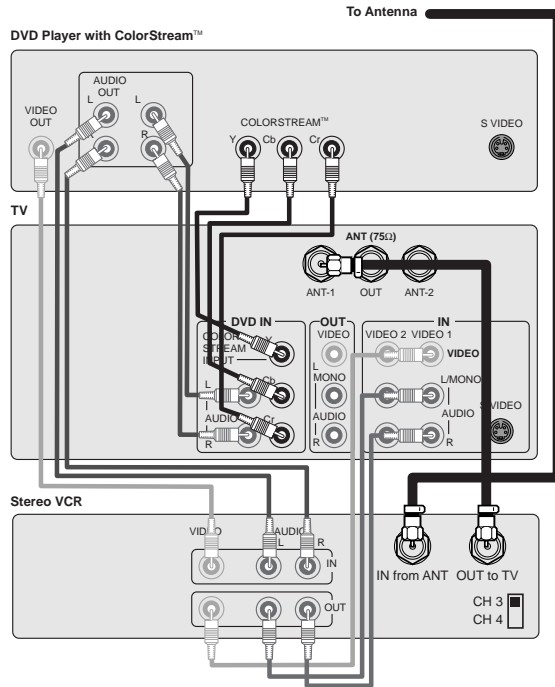

Note:

To play from the DVD, the DVD and TV must use ColorStream connections. To record from the DVD, the DVD and TV must select Video.

Connecting two VCRs

This connection allows you to record from one VCR to another VCR while watching a video program. You also will be able to record from one TV channel while watching another channel.

You will need:

- one coaxial cable
- two pairs of audio cables (two single cables for mono VCRs)
- two video cables

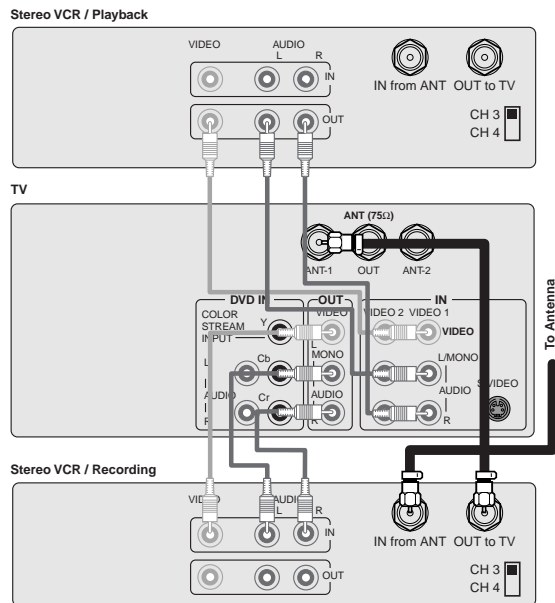

Note:

If you are using an S-VHS VCR, use the S-video connections and omit the video cable.

Caution:

Do not connect one VCR to the output and input jacks on the TV at the same time.

Do not connect the video cable and the S-video cable to Video-1 simultaneously.

Connecting a camcorder

This connection allows you to watch videos recorded on a camcorder.

You will need:

- one pair of audio cables
- one video cable

Note:

If you are using an S-VHS camcorder with an S-video output, connect this to the S-video input on the TV and omit the video cable.

Caution:

Do not connect the video cable and the S-video cable to Video-1 simultaneously.

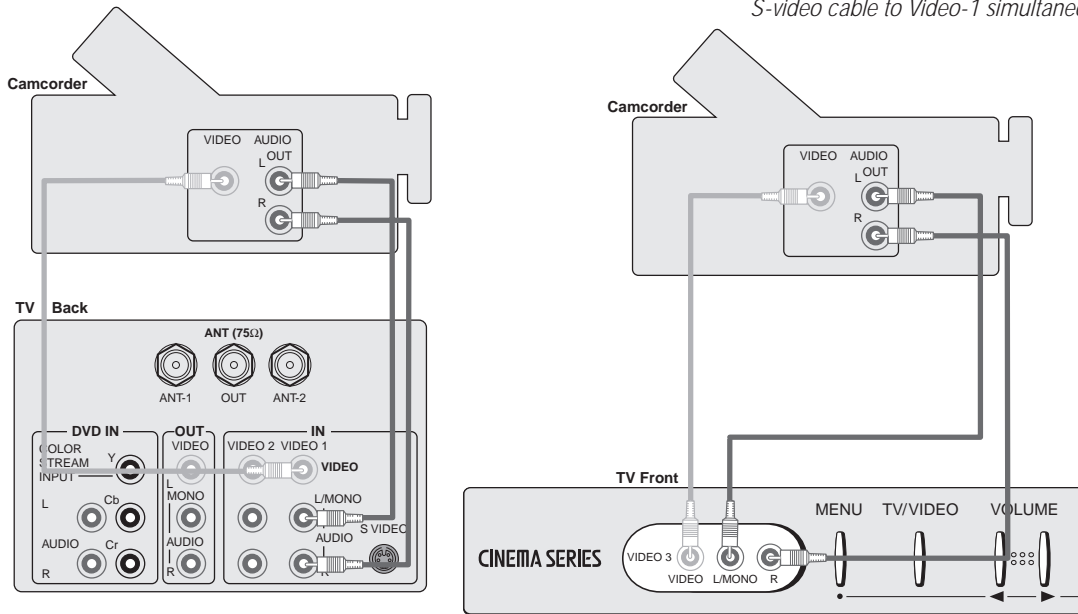

Connecting an audio amplifier

This connection allows you to use an audio amplifier to adjust the audio level. This connection also allows you to use external speakers.

To control the audio, turn on the TV and the stereo amplifier.

You will need:

- one pair of audio cables

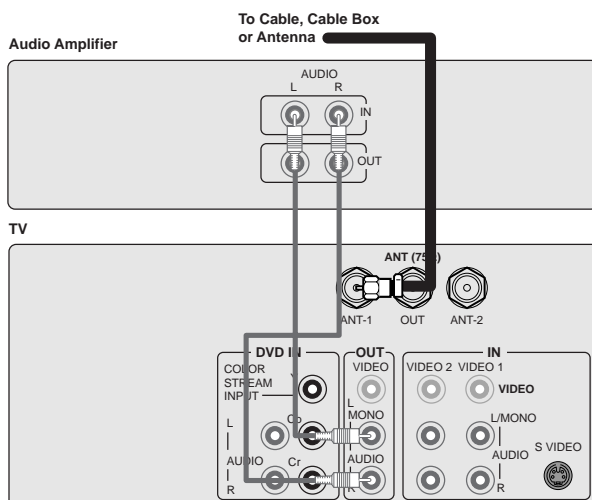

Using the remote control

Preparing the remote control for use

The remote control will operate your TV, most VCR models, and most cable TV converters together, even if they are different brands. If you will be using your TV with a Toshiba VCR, your remote control is already programmed and ready to use. If you own different brands of VCRs and/or converters, you will need to program your remote control (see "Programming the remote control for use with a VCR or cable TV converter" on page 8).

Installing the remote control batteries

To install the batteries:

1. Slide the battery cover off the back of the remote control.

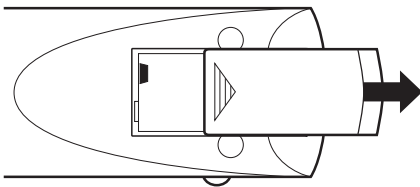

2. Install two "AA" size batteries. Match the + and - symbols on the batteries to the symbols on the battery compartment.

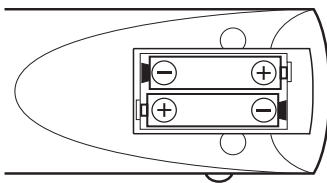

3. Slide the battery cover back onto the remote control until the lock snaps.

Using the remote control with a VCR or cable TV converter

To control a Toshiba VCR:

Set the TV/CABLE/VCR switch to the VCR position. The shaded buttons in the illustration at right will then control the VCR. The unshaded buttons will operate the TV as usual.

To control a cable TV converter:

Program the remote control to recognize the brand of your converter (see "Programming the remote control for use with a VCR or cable TV converter" on page 8). Set the TV/CABLE/VCR switch to the CABLE position. The shaded buttons in the top portion of the illustration at right will then control the cable TV converter.

Note:

The remote control provided with your TV may or may not operate certain features on your VCR, cable TV converter, or other electronic components. Refer to the owner's manuals provided with your other components to see which features are available. In addition, the other remote controls may have buttons not available on your TV's remote control. If you would like to use those features or buttons, you may need to use the original remote controls for your other components.

Caution:

- Dispose of batteries in a designated disposal area. Do not throw batteries into a fire.
- Do not mix battery types or combine used batteries with new ones.
- Remove dead batteries immediately to prevent battery acid from leaking into the battery compartment.
- If you do not intend to use the remote control for a long time, remove the batteries.

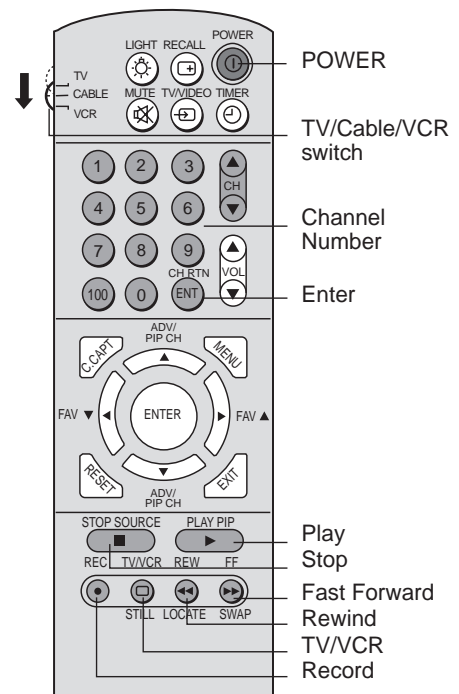

Programming the remote control for use with a VCR or cable TV converter

The remote control provided with your Toshiba TV is preprogrammed to operate Toshiba VCRs also.

To operate non-Toshiba components using the remote control provided with your TV:

1. Refer to the VCR and cable TV converter code table below to find the corresponding code for your VCR or cable TV converter brand.
If more than one code is listed, try each one separately until you find the one that works.
2. If you are reprogramming the remote control to operate your:
 - **VCR:** Set the TV/CABLE/VCR switch on the remote control to VCR.
 - **Cable TV converter:** Set the TV/CABLE/VCR switch on the remote control to CABLE.
3. Hold down the RECALL button while using the Channel Number buttons to enter the three-digit code of your VCR or cable TV converter brand.
4. Point the remote control at the VCR or converter and press POWER to test the code.
 - If the VCR or converter turns on, you have entered the correct code.
 - If the VCR or converter does not respond to the remote control, you may have entered the incorrect code. Repeat steps 1–4 using another code.
5. Reset the TV/CABLE/VCR switch to TV to control the TV.

For future reference, write down the codes you used:

VCR code _____

Cable TV converter code _____

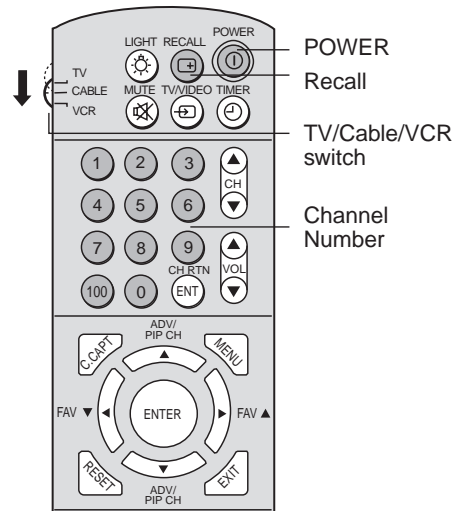

Note:

- Every time you replace the batteries, you will need to reprogram the remote control.
- Some newer VCRs are capable of working on either of two remote codes. These VCRs have a switch labeled "VCR1/VCR2." If your VCR has this kind of switch, it may not respond to any of the codes for your VCR brand. In this case, set the switch to the other position (VCR1 or VCR2) and reprogram the remote control.

VCR code table

Brand	Code	Brand	Code	Brand	Code
Adventura	019	CCE	091, 297	Fisher	066, 073, 085, 123
Aiko	297	Citizen	056, 297	Fuji	052, 054
Aiwa	019	Colt	091	Funai	019, 344
Akai	060, 068, 080, 125, 261	Craig	056, 066, 091, 259	Garrard	019, 344
American High	054	Curtis Mathes	054, 060, 079	GE	054, 079, 084, 221
Asha	259	Cybernex	259	Go Video	251, 298
Audiovox	056	Daewoo	039, 064, 297	Goldstar	037, 056, 057
Beaumont	259	Daytron	039	Gradiente	019
Bell & Howell	123	Dynatech	019	Harley Davidson	019
Brandt	206	Electrohome	056	Harman/Kardon	057, 094
Broksonic	140, 203, 230, 314, 380	Electroponic	056	Harwood	087, 091
Calix	056	Emerex	051	Headquarter	065
Canon	054	Emerson	019, 021, 056, 062, 080, 087, 140, 203, 227, 228, 230, 231, 297, 313, 314, 380, 498	HI-Q	066
Capehart	039			Hitachi	060, 061, 084, 124, 185, 254
Carver	100			Jensen	060
				JVC	027, 060, 086
				Kenwood	057, 060, 086

VCR code table (cont.)

Brand	Code	Brand	Code	Brand	Code
KLH	091	Sanky	058, 067	Garrard	172
Kodak	054, 056	Sansui	060, 086	CG Electronics	075
Lloyd	019, 227	Sanyo	065, 066, 123, 259	Gemini	034, 089
Logik	091	Scott	062, 064, 140, 203, 229, 230, 231	General Instrument	030, 295
LXI	056	Sears	054, 056, 061, 065, 066, 073, 085, 123, 124	Gold Star	059, 163
Magnavox	054, 058, 100, 129, 168	Sharp	067, 081	Hamlin	028, 039, 053, 278, 292
Magnin	259	Shintom	091	Hitachi	030
Marantz	054, 100	Shogun	259	Hytex	026
Marta	056	Singer	091	Jasco	172
Matsushita	054	Sony	051, 052, 053, 054	Jerrold	022, 030, 031, 033, 034, 066, 295
MEI	054	STS	061	Macom	052
Memorex	019, 054, 056, 058, 065, 066, 067, 123, 259	Sylvania	019, 054, 062, 100, 129	Magnavox	046
MGA	062, 080	Symphonic	019, 344	Memorex	019
MGN Technology	259	Tatung	060	Movietime	175
Minolta	061, 124	Teac	019, 060	NSC	089, 175
Mitsubishi	062, 080, 086, 094, 192, 233, 261	Technics	054, 181	Oak	026, 038, 267
Motorola	054, 067	Teknika	019, 054, 056, 071	Panasonic	019, 040, 126
MTC	019, 259	Telefunken	206	Paragon	019
Multitech	019, 091	TMK	227, 259	Philips	044, 046, 047, 048, 049, 050, 172
NAD	077	Toshiba	062, 064, 085, 229, 231, 385	Pioneer	042, 163, 552
NEC	057, 059, 060, 069, 086	Totevision	056, 259	Popular Mechanics	419
Nikko	056	Unitech	259	Pulsar	019
Noblex	259	Vector	064	RCA	040
Olympus	054	Vector Research	057, 059	Regal	039, 278, 292
Optimus	056, 067, 077, 123	Video Concepts	059, 064, 080	Recoton	419
Optonica	081	Videosonic	259	Regency	021
Orion	498	Wards	019, 054, 061, 066, 067, 081, 091, 168, 231, 259	Rembrandt	030, 089
Panasonic	054, 096, 181, 244, 473	XR-1000	019, 054, 091	Runco	019
Penney	054, 056, 057, 059, 061, 073, 259	Yamaha	057	Samsung	059, 163
Pentax	061, 084, 124	Zenith	052, 053, 058	Scientific Atlanta	025, 027, 036, 296
Philco	054			Signal	034, 059
Philips	054, 081, 100, 129			Signature	030
Pilot	056			SL Marx	059
Pioneer	077, 086			Sprucer	040
Portland	039			Standard	
Protec	091			Components	174
Pulsar	058			Starcom	022, 034, 066
Quarter	065			Stargate	034, 059
Quartz	065			Starquest	034
Quasar	054, 096			Sylvania	020
Radio Shack	019, 056, 344			Teleview	059
Radix	056			Texscan	020
Randex	056			Tocom	031, 032, 078
RCA	061, 079, 084, 096, 124, 125, 168, 221			Toshiba	019
Realistic	019, 054, 056, 065, 066, 067, 081, 085, 123, 259			Tusa	034
Ricoh	053			Unika	041, 172
Runco	058			United Artists	026
Samsung	064, 259			United Cable	022
				Universal	041, 058, 075, 096, 172, 210
				Viewstar	046, 079, 230
				Zenith	019
				Zentek	419

Cable TV converter code table

Brand	Code
ABC	020, 022, 027, 030, 032, 033, 036, 066
Antronix	041
Archer	041, 058, 172
Belcor	075
Cable Star	075
Cabletenna	041
Cableview	041
Century	172
Citizen	172
Colour Voice	044, 050
Comtronics	059, 079
Contec	038
Dae Ryung	027
Eastern	021
Focus	419

Learning about the remote control

POWER turns the TV on and off (page 8)

TV/VIDEO selects input source (page 12)

Channel ▲▼ cycles through programmed channels (page 12)

TV/Cable/VCR switch switches between TV, Cable, and VCR (page 7)

Channel Numbers allow direct access to channels (page 13)

Volume ▲▼ adjusts the volume level (page 29)

Channel Return returns to the last viewed channel (page 13)

MENU allows access to programming menus (page 11)

Favorite Channels ▲▼ cycles through channels programmed as favorite channels (page 14)

ENTER sets programmed menu information (page 13)

EXIT exits programming menus (page 11)

PIP Buttons allow access to PIP functions (pages 24–25)

STILL freezes the small PIP

SOURCE selects the PIP input source

PIP selects the picture-in-picture (PIP) mode

PIP CH ▲▼ changes the small PIP channel

LOCATE changes the position of the small PIP

SWAP switches the main picture and small PIP

STOP stops a videotape

REC starts recording a videotape

PLAY plays a videotape

FF fast forwards a videotape

REW rewinds a videotape

TV/VCR toggles between TV and VCR when viewing while recording

MUTE mutes the sound (page 29)

RECALL displays on-screen information (page 27)

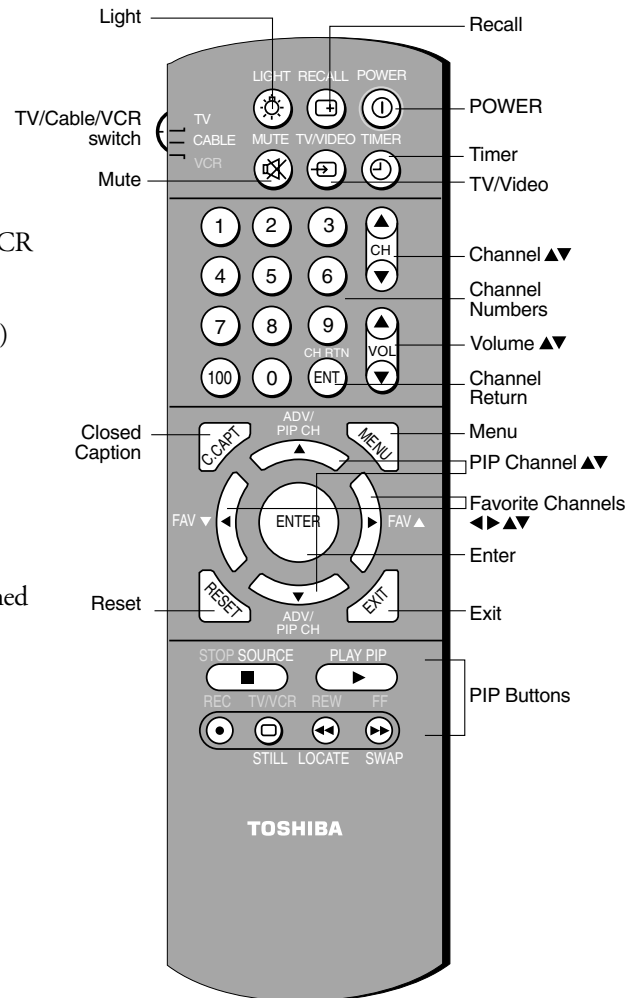

Setting up your TV

After you have installed the batteries and programmed the remote control, you will need to use the menu to set some preferences on your TV. You can access the menu using the buttons on your TV or remote control.

- When you make a menu selection, your changes occur immediately. You do not have to press MENU or EXIT to save your changes.
- When you are finished programming the menus, you can press EXIT to clear the on-screen display, or wait 15 seconds and the on-screen display will disappear automatically. Your changes are automatically saved either way.

Changing the on-screen display language

You can choose from three different languages (English, French, and Spanish) for the on-screen displays. Menus and messages will appear in the language you select.

To select an on-screen display language:

1. Press MENU.
2. Press ◀ or ▶ until the SET UP menu appears.
3. Press ▲ or ▼ to highlight LANGUAGE.
4. Press ◀ or ▶ to highlight your desired language.

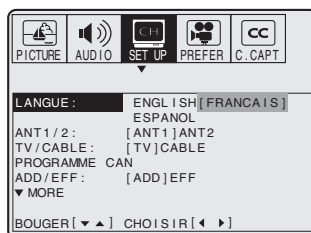
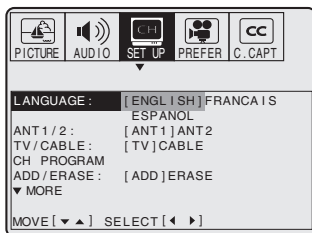

Selecting the antenna input

You can connect to one of two different antenna input sources using the antenna input (ANT 1 or ANT 2).

To select the antenna input:

1. Press MENU.
2. Press ◀ or ▶ to highlight the SET UP menu.
3. Press ▲ or ▼ to highlight ANT 1/2.
4. Press ◀ or ▶ to highlight either ANT 1 or ANT 2, depending on the antenna terminal you wish to use.

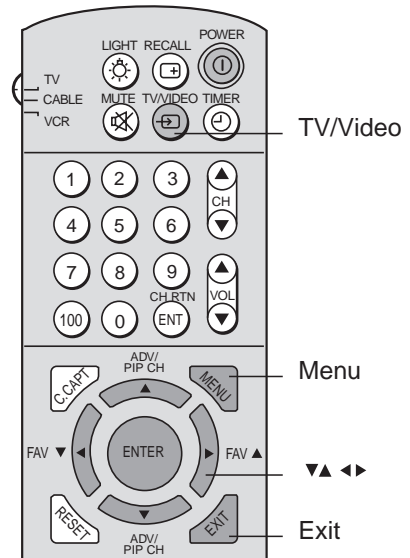
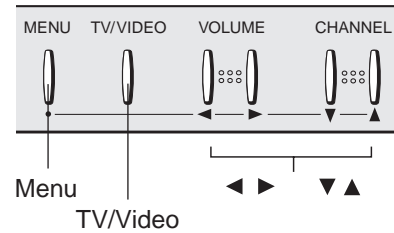
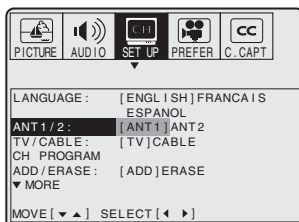

Using the TV/VIDEO button on the TV

Use the TV/VIDEO button on the TV to monitor or change the signal source connected to your TV.

To select the signal source:

Press the TV/VIDEO button on the TV to select either VIDEO 1, VIDEO 2, VIDEO 3, ColorStream, ANT 1, or ANT 2. Repeatedly press the TV/VIDEO button on the TV until the signal source you wish to use displays in purple.

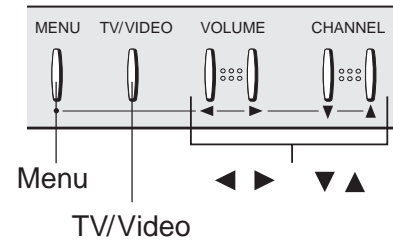
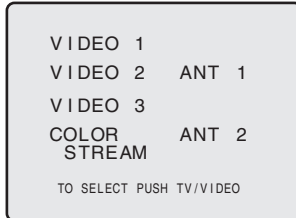

Adding channels to the TV's memory

When you press Channel ▲ or ▼ on the TV or remote control, the TV stops only on the channels stored in the TV's memory.

Note: To tune the TV to a channel not programmed in the TV's memory, use the Channel Number buttons on the remote control.

Follow the steps below and on the next page to program channels into the TV's memory.

Programming channels automatically

Your TV can automatically detect all active channels in your area and store them in the TV's memory. After the channels are stored automatically, you can manually add or erase individual channels (see page 13). If you use both ANT-1 and ANT-2 terminals, you will need to program channels for each input source.

To program channels automatically:

1. Press MENU.
2. Press ◀ or ▶ to highlight the SET UP menu.
3. Press ▲ or ▼ to highlight TV/CABLE.
4. Press ◀ or ▶ to highlight either TV or CABLE, depending on which you use. If you use an antenna, highlight TV. If you use cable, highlight CABLE.
5. Press ▼ to highlight CH PROGRAM.

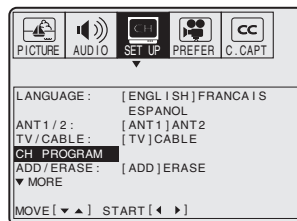
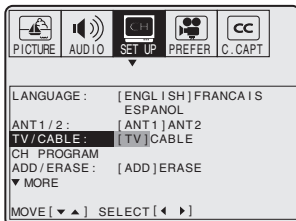

6. Press ◀ or ▶ to start automatic channel programming. The TV automatically cycles through every TV or cable channel (depending on which you selected), and stores all active channels in the TV's memory.
7. When automatic channel programming is complete, the message "CH Programming Completed" appears.
8. Press Channel ▲ or ▼ to view the programmed channels.

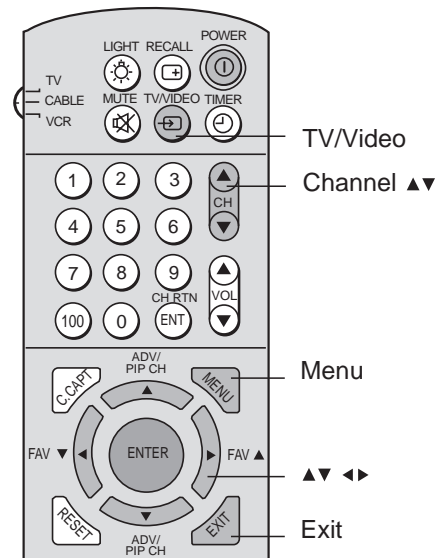

Adding and erasing channels manually

After you have automatically programmed the channels into the TV's memory, you can manually add and erase individual channels.

To add a channel to or erase a channel from the TV's memory:

1. Tune the TV to the channel you want to add or erase. If you are adding a channel, you will need to use the Channel Number buttons to select the channel.
2. Press MENU.
3. Press ◀ or ▶ to highlight the SET UP menu.
4. Press ▲ or ▼ to highlight ADD/ERASE.

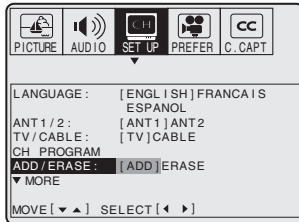

5. Press ◀ or ▶ to highlight ADD or ERASE, whichever function you want to perform.
6. Press ENTER.
7. Press EXIT to return to normal TV viewing.
8. Repeat steps 1–7 for other channels you want to add or erase.

Changing channels

To change to the next programmed channel:

Press Channel ▲ or ▼ on the TV, or CH ▲ or ▼ on the remote control.

To change to a specific channel (programmed or unprogrammed):

Press the Channel Number buttons (0–9 and 100). **Note:** For channels 100 and higher, press the 100 button, then the next two channel numbers (for example, to select channel 100, press 100–0–0; to select channel 125, press 100–2–5).

Using the TV's features

Adjusting the channel settings

Switching between two channels

You can switch between two channels without entering an actual channel number each time.

To switch between two channels:

1. Select the first channel you want to view.
2. Select a second channel using the Channel Number buttons (0–9 and 100).
3. Press CH RTN. The previous channel will display.

Every time you press CH RTN, the TV will switch back and forth between the last two channels you tuned the TV to.

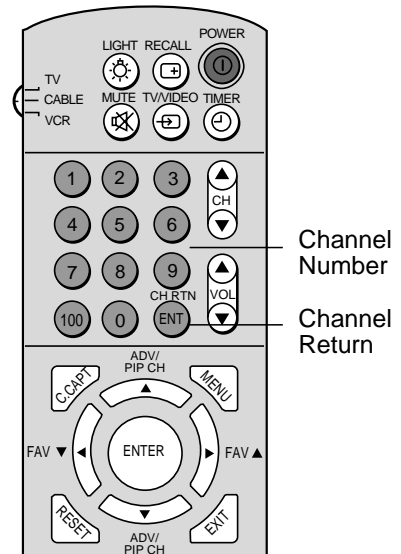
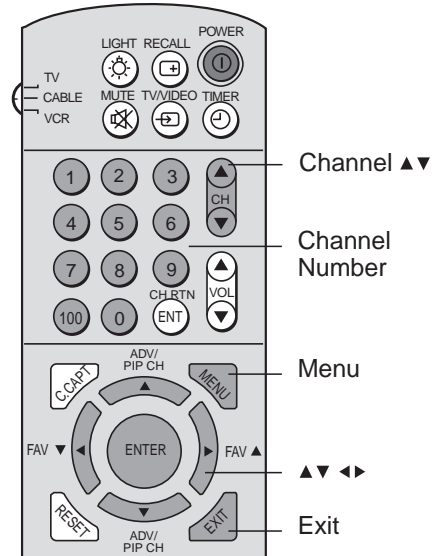
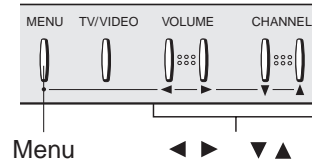

Programming your favorite channels

The Favorite Channel feature allows you to use the FAV ▲▼ buttons on the remote control to cycle through your favorite channels and skip over channels you do not normally watch. You can program a maximum of 12 favorite channels.

Note: You can still use Channel ▲▼ to cycle through all the channels you programmed into the TV's memory.

To program your favorite channels:

1. Tune the TV to a channel you want to program as a favorite channel.
2. Press MENU.
3. Press ◀ or ▶ to highlight the SET UP menu.
4. Press ▲ or ▼ to highlight FAVORITE CH.

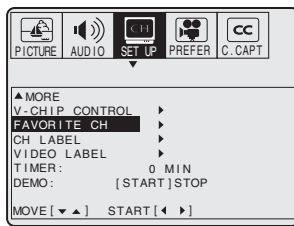

5. Press ◀ or ▶ to display the FAVORITE CH menu. SET/CLEAR will be highlighted.
6. Press ◀ or ▶ to highlight SET.
7. Press ▼ to add the current channel to the list.
8. Press ENTER.

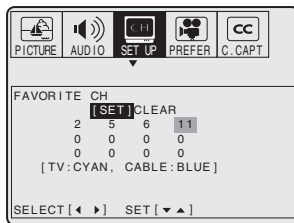

9. Press EXIT to close the on-screen display.
10. Repeat steps 1–9 for a maximum of 12 channels.

To select your favorite channels:

Press FAV ▲ or ▼ on the remote control to cycle through the favorite channels you programmed.

Note: The Favorite Channel feature will not work unless you program at least one favorite channel.

To clear a favorite channel:

1. Tune the TV to the channel you want to clear from your favorite channel list.
2. Press MENU.
3. Press ◀ or ▶ to highlight the SET UP menu.
4. Press ▲ or ▼ to highlight FAVORITE CH.

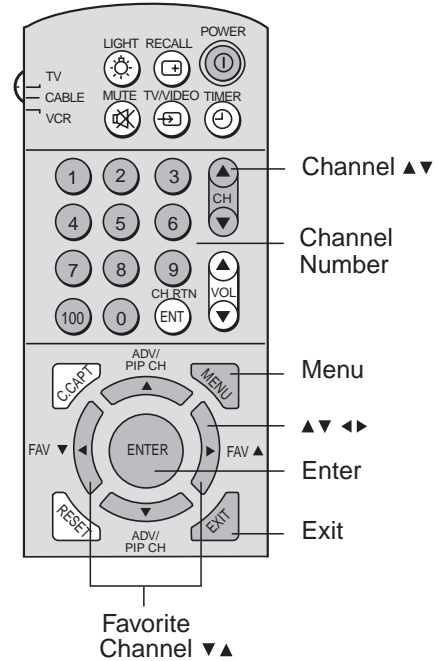

- Press ◀ or ▶ to display the FAVORITE CH menu. SET/CLEAR will be highlighted.
- Press ◀ or ▶ to highlight CLEAR.

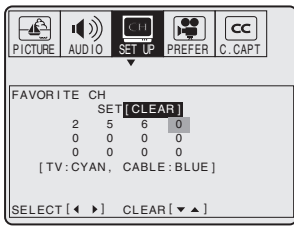

- Press ▼, which clears the current channel number from the list.
- Press ENTER.
- Press EXIT to close the on-screen display.
- Repeat steps 1–9 for other channels you want to clear from your favorite channel list.

Using the V-Chip

You can use the V-Chip feature to block certain programs or channels, thereby preventing others from viewing them.

Selecting a PIN code

Before you can block programs and channels, you need to select a personal identification number (PIN) code. The PIN code you select allows you to access the V-Chip menu and prevents others from changing the rating and blocking limits you set.

To select your PIN code and access the V-Chip menu:

- Press MENU.
- Press ◀ or ▶ to highlight the SET UP menu.
- Press ▲ or ▼ to highlight V-CHIP CONTROL.
- Press ◀ or ▶ to display the Enter PIN Code screen.

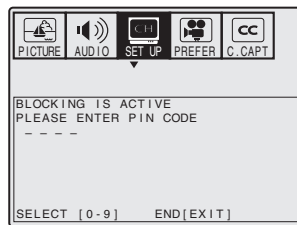
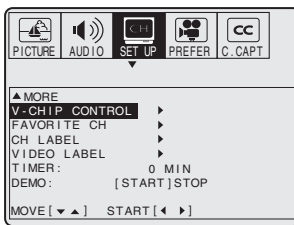

- Use the Channel Number buttons (0–9) to enter your PIN code. If you are accessing the V-Chip menu for the first time, select a four-digit number to be your PIN code. After the code is entered, the V-Chip Control menu appears.
- Press ▲ or ▼ to highlight ENABLE BLOCKING.

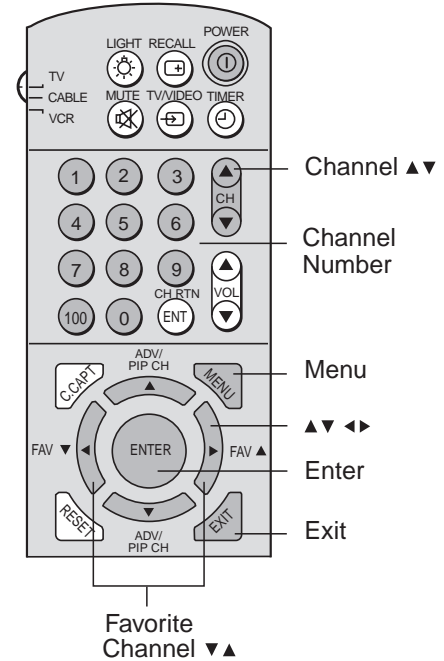

- Press ◀ or ▶ to highlight “Y,” which enables all blocking by activating the V-Chip. See “Blocking programs by ratings” on page 17, “Blocking unrated movies or programs” on page 19, and “Blocking channels” on page 20.

(**Note:** Highlight “N” to deactivate the V-Chip and disable blocking.)

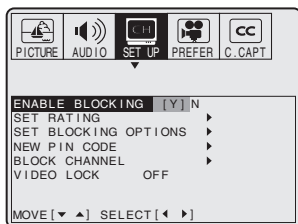

To change your PIN code:

- Press MENU.
- Press ◀ or ▶ to highlight the SET UP menu.
- Press ▲ or ▼ to highlight V-CHIP CONTROL.
- Press ◀ or ▶ to display the Enter PIN Code screen.
- Use the Channel Number buttons (0–9) to enter your existing PIN code. After the code is entered, the V-Chip Control menu appears.
- Press ▲ or ▼ to highlight NEW PIN CODE.
- Press ◀ or ▶ to display the New PIN Code screen.

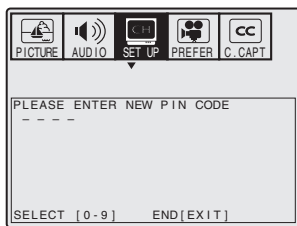
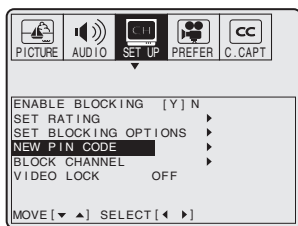

- Use the Channel Number buttons (0–9) to enter a new code. After the new code is entered, the V-Chip Control menu appears.
- Press EXIT to return to normal TV viewing.

Note:

If you forget your PIN code, follow steps 1–4 under “To change your PIN code” at left, then press **RECALL** four times within five seconds. This allows you to proceed to the V-Chip Control menu and reset your PIN code.

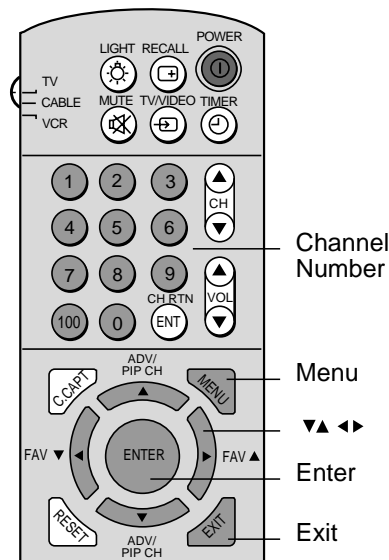

Blocking programs by ratings

The Motion Picture Association of America (MPAA) uses a rating system to qualify motion picture content. Television broadcasters employ a similar rating system to qualify the content of television programs. The MPAA, Youth TV, and TV ratings work with the V-Chip feature to allow you to block access to programs that exceed the rating limits you set.

Ratings definitions

MPAA Ratings

X	For adults only.
NC17	Not intended for anyone 17 or under.
R	Restricted. Under 17 requires an accompanying parent or adult guardian.
PG13	Parents strongly cautioned. Some material may not be appropriate for children under 13.
PG	Parental guidance suggested. Some material may not be appropriate for children.
G	General audience. Appropriate for all ages.

Youth TV Ratings

Y7 Y7FV	Directed to older children. Programs rated Y7 are designed for children 7 and above. Programs in which fantasy violence may be more intense or combative than other programs in this category are rated Y7FV.
Y	For all children. Programs rated Y are designed to be appropriate for all children.

TV Ratings

MA	Mature audience only. This program is specifically designed to be viewed by adults and therefore may be unsuitable for children under 17.
	Language Crude or indecent language.
	Sex Explicit sexual activity.
	Violence Graphic violence.
14	Parents strongly cautioned. This program contains some material that many parents would find unsuitable for children under 14 years of age.
	Dialog Intensely suggestive dialog.
	Language Strong, coarse language.
	Sex Intense sexual situations.
	Violence Intense violence.
PG	Parental guidance suggested. This program contains material that parents may find unsuitable for younger children.
	Dialog Some suggestive dialog.
	Language Infrequent coarse language.
	Sex Some sexual situations.
	Violence Moderate violence
G	General audience. Most parents would find this program suitable for all ages.
No DLSV	Programs without any Dialog, Language, Sex, or Violence ratings.

Note:

Press **RECALL** to see the rating of the program you are viewing.

To use the V-Chip to block programs by rating:

1. Press MENU.
2. Press ◀ or ▶ to highlight the SET UP menu.
3. Press ▲ or ▼ to highlight V-CHIP CONTROL.
4. Press ◀ or ▶ to display the Enter PIN Code screen.
5. Use the Channel Number buttons (0–9) to enter your PIN code. If you are accessing the V-Chip menu for the first time, select a four-digit number to be your PIN code. After the code is entered, the V-Chip Control menu appears.
6. Press ▲ or ▼ to highlight ENABLE BLOCKING.
7. Press ◀ or ▶ to highlight “Y,” which enables all blocking by activating the V-Chip.

(Note: Highlight “N” to deactivate the V-Chip and disable blocking.)

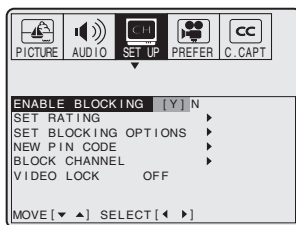

8. Press ▲ or ▼ to highlight SET RATING.
9. Press ◀ or ▶ to display the Set Rating menu.
10. Press ▲ or ▼ to highlight MPAA Rating, Youth TV Rating, or TV Rating.
11. Press ▶ to select (or ◀ to deselect) the ratings to be blocked. Blocked ratings are signified with the symbol “x.” Unblocked ratings are signified with the symbol “✓.” As you block ratings, all ratings higher than the ones you select are blocked as well. For example, if you block the MPAA rating R, the higher ratings NC17 and X will also be blocked.

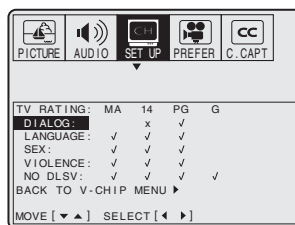
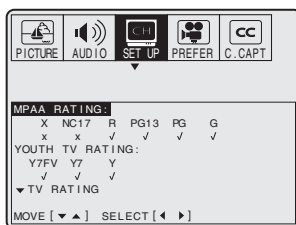

12. When you finish selecting the ratings to be blocked:
 - To return to the V-Chip menu, press ▲ or ▼ to highlight BACK TO V-CHIP MENU, then press ◀ or ▶.
 - To return to normal TV viewing, press EXIT.

Note:

Not all programs are rated. To block programs or movies that are unrated, see “Blocking unrated movies and programs” on page 19.

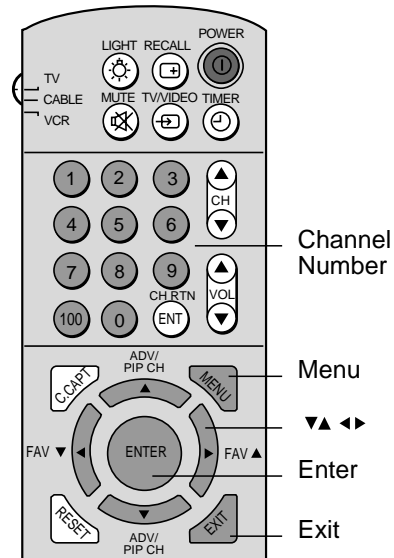

Note: When you try to view a program with a ratings block, a message appears stating that the program has been blocked because the program's rating exceeds the set limits. To temporarily override the block and view the program, press MUTE and enter your PIN code. To reset your original ratings blocks, turn the TV off and then on again.

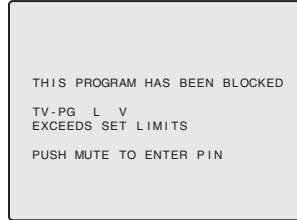
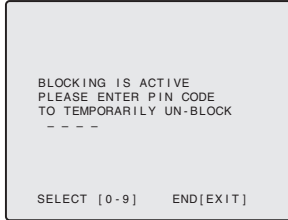

Blocking unrated movies and programs

Some movies and programs are not rated. You can use the V-Chip to block unrated movies and programs.

To block unrated movies and programs:

1. Press MENU.
2. Press ◀ or ▶ to highlight the SET UP menu.
3. Press ▲ or ▼ to highlight V-CHIP CONTROL.
4. Press ◀ or ▶ to display the Enter PIN Code screen.
5. Use the Channel Number buttons (0–9) to enter your PIN code. If you are accessing the V-Chip menu for the first time, select a four-digit number to be your PIN code. After the PIN code is entered, the V-Chip Control menu appears.
6. Press ▲ or ▼ to highlight ENABLE BLOCKING.
7. Press ◀ or ▶ to highlight “Y,” which enables all blocking by activating the V-Chip.
(**Note:** Highlight “N” to deactivate the V-Chip and disable blocking.)
8. Press ▲ or ▼ to highlight SET BLOCKING OPTIONS.
9. Press ◀ or ▶ to display the unrated movie/program blocking menu.
10. Press ▲ or ▼ to highlight BLOCK TV NONE RATING.
11. Press ◀ or ▶ to highlight “Y” to block movies/programs rated “TV None.” (**Note:** Highlight “N” to unblock unrated programs.)
12. Press EXIT to return to normal TV viewing.

Caution:

Blocking unrated television programs (with a rating of “TV NONE”) may block emergency messages.

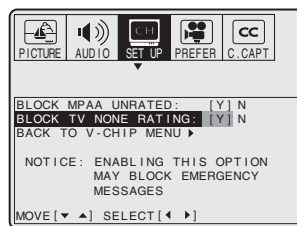
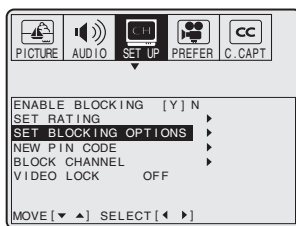
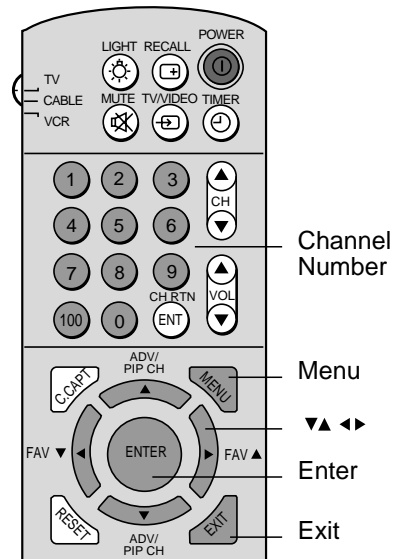

Blocking channels

You can block a maximum of four TV channels and four cable channels. Blocked channels cannot be viewed regardless of their ratings. If you try to display a blocked channel, the TV will display the nearest unblocked channel.

To block a channel:

1. Tune the TV to the channel you want to block.
2. Press MENU.
3. Press ◀ or ▶ to highlight the SET UP menu.
4. Press ▲ or ▼ to highlight V-CHIP CONTROL.
5. Press ◀ or ▶ to display the Enter PIN Code screen.
6. Use the Channel Number buttons (0–9) to enter your PIN code. If you are accessing the V-Chip menu for the first time, choose a four-digit number to be your PIN code. After entering the code, the V-Chip Control menu appears.
7. Press ▲ or ▼ to highlight ENABLE BLOCKING.
8. Press ◀ or ▶ to highlight “Y,” which enables all blocking by activating the V-Chip.
(**Note:** Highlight “N” to deactivate the V-Chip and disable blocking.)
9. Press ▲ or ▼ to highlight BLOCK CHANNEL.
10. Press ◀ or ▶ to display the BLOCK CHANNEL menu. SET/CLEAR will be highlighted.
11. Press ◀ or ▶ to highlight SET.
12. Press ▼ to add the current channel to the list.
13. Press ENTER.

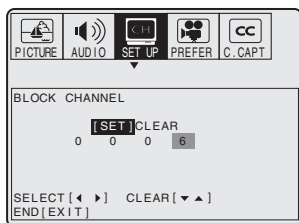

14. Press EXIT.
15. Repeat steps 1–14 to block additional channels.

To unblock all blocked channels:

Note: This will unblock every channel you have blocked. You cannot unblock individual channels.

1. Press MENU.
2. Press ◀ or ▶ to highlight the SET UP menu.
3. Press ▲ or ▼ to highlight V-CHIP CONTROL.
4. Press ◀ or ▶ to display the Enter PIN Code screen.
5. Use the Channel Number buttons (0–9) to enter your PIN code. If you are accessing the V-Chip menu for the first time, choose a four-digit number to be your PIN code. After entering the code, the V-Chip Control menu appears.

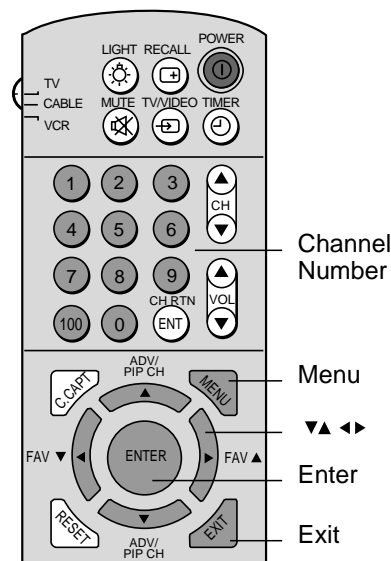

Note:

After programming CHANNEL BLOCK, change channels before turning off the television.

6. Press ▲ or ▼ to highlight BLOCK CHANNEL.
7. Press ◀ or ▶ to display the BLOCK CHANNEL menu. SET/CLEAR will be highlighted.
8. Press ◀ or ▶ to highlight CLEAR.
9. Press ▼ to clear all blocked channels from the list.
10. Press ENTER.
11. Press EXIT to return to normal TV viewing.

Video Lock

You can use the Video Lock feature to block the input sources (Video 1, Video 2, Video 3, and ColorStream) and channels 3 and 4.

Note: The Video Lock feature is independent of the Enable Blocking option of V-Chip control.

The Video Lock options are:

- Video: Blocks Video 1, Video 2, Video 3, and ColorStream.
- Video+: Blocks Video 1, Video 2, Video 3, ColorStream, and channels 3 and 4.
- Off: Disables the Video Lock feature.

To set up video lock:

1. Press MENU.
2. Press ◀ or ▶ to highlight the SET UP menu.
3. Press ▲ or ▼ to highlight V-CHIP CONTROL.
4. Press ◀ or ▶ to display the Enter PIN Code screen.
5. Use the Channel Number buttons (0–9) to enter your PIN code. If you are accessing the V-Chip menu for the first time, choose a four-digit number to be your PIN code. After entering the code, the V-Chip Control menu appears.
6. Press ▲ or ▼ to highlight VIDEO LOCK.
7. Press ◀ or ▶ to select the desired level of video locking (Video, Video+, or Off).

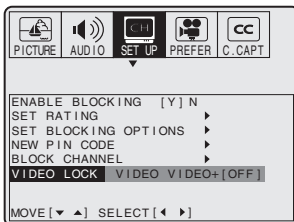

8. Press EXIT to return to normal TV viewing.

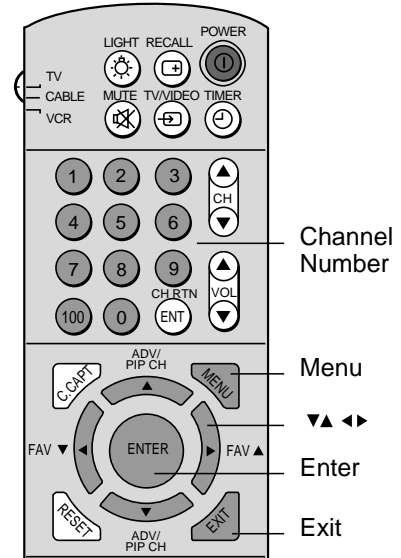

Note:

In normal TV viewing, if you cannot access the input sources (Video 1, Video 2, Video 3, and ColorStream) or channels 3 and 4, check the Video Lock setting and highlight OFF if necessary.

Channel labels

A channel label displays on the screen above the channel number every time you turn the TV on, change the channel, or press RECALL. You can choose up to four characters for a channel label.

To create a channel label:

1. Tune the TV to the channel you want to label.
2. Press MENU.
3. Press ◀ or ▶ to highlight the SET UP menu.
4. Press ▲ or ▼ to highlight CH LABEL.

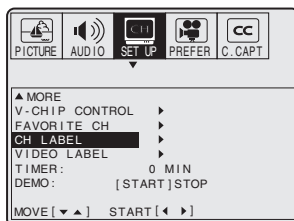

5. Press ◀ or ▶ to display the CH LABEL menu. SET/CLEAR will be highlighted.
6. Press ◀ or ▶ to highlight SET.
7. Press ▼ to highlight LABEL.

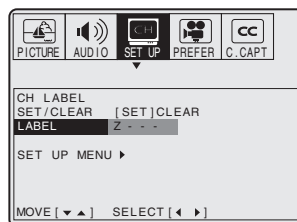
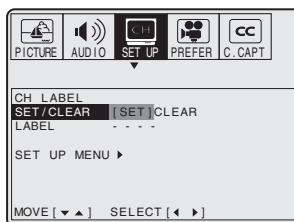

8. Press ◀ or ▶ repeatedly to scan through the list of available characters until the desired character appears in the first space.
9. Press ENTER.
10. Repeat steps 8 and 9 to enter the rest of the characters.

Note: For a blank space in the label name, you need to choose an empty space from the list of characters; otherwise, a dash will appear in the space.
11. Press EXIT to return to normal TV viewing.
12. Repeat steps 1–11 for other channels. You can assign labels to a maximum of 32 channels.

To erase a channel label:

1. Select the channel whose label you want to erase.
2. Press MENU.
3. Press ◀ or ▶ to highlight the SET UP menu.
4. Press ▲ or ▼ to highlight CH LABEL.
5. Press ◀ or ▶ to display the CH LABEL menu. SET/CLEAR will be highlighted.
6. Press ◀ or ▶ to highlight CLEAR.
7. Press ENTER.
8. Press EXIT to return to normal TV viewing.
9. Repeat steps 1–8 to erase other channel labels.

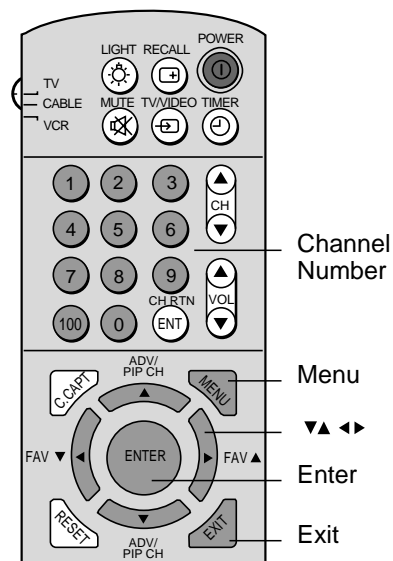

Video labels

The Video Label feature allows you to label each input source for your TV from the following preset list of labels:

-: Uses the default label name

VCR: Video cassette recorder

DVD: Digital video disc or digital versatile disc

DTV: Digital TV set-top box

SAT: Satellite box

CBL: Cable box

To set up video labels:

1. Press MENU.
2. Press ◀ or ▶ to highlight the SET UP menu.
3. Press ▲ or ▼ to highlight VIDEO LABEL.
4. Press ◀ or ▶ to display the Video Label screen.
5. Press ▲ or ▼ to highlight the input source to be labeled.
6. Press ◀ or ▶ to select the desired label for that input source.

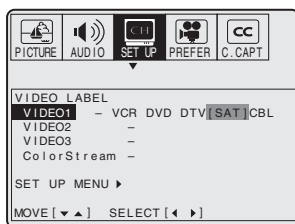

7. Repeat steps 1–6 to label the other input sources.
8. When you finish setting up video labels:
 - To return to the previous menu, press ▲ or ▼ to highlight SET UP MENU, then press ◀ or ▶.
 - To return to normal TV viewing, press EXIT.

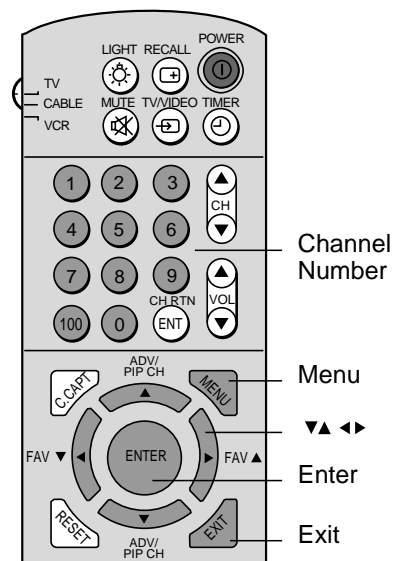

Watching picture-in-picture (PIP)

The picture-in-picture (PIP) feature allows you to watch two pictures at the same time. The small picture can come from a TV broadcast or an external source, such as a VCR.

(Note: ColorStream cannot be accessed in PIP mode.)

To display a TV broadcast as a small picture:

1. Tune the TV to the program you want to watch.
2. Press the PIP button once to display a small picture. A window 1/9 the size of the screen will appear. Press PIP a second time to display a 1/16-size window.

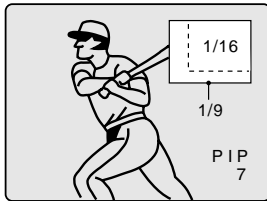

3. Press PIP Channel ▲ or ▼ to choose the program you want to display as a small picture.

To display a picture from an external source as a small picture:

1. Make sure you have connected the external source equipment properly. For more information, see “Connecting your TV” on page 2.
2. Turn on the TV and select the program you want to watch.
3. Press the PIP button once to display a small picture. A window 1/9 the size of the screen will appear. Press PIP a second time to display a 1/16-size window.
4. Press SOURCE to select the input source (TV, VIDEO 1, VIDEO 2, or VIDEO 3) for the small picture. The selected source will be displayed in purple.

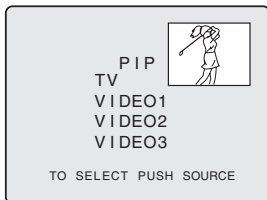

To turn PIP off:

Press PIP two or three times, depending on the size of the small picture screen you selected.

Switching the main and small pictures

With the TV in PIP mode, press SWAP to switch the main and small pictures. The main and small pictures switch every time you press the SWAP button.

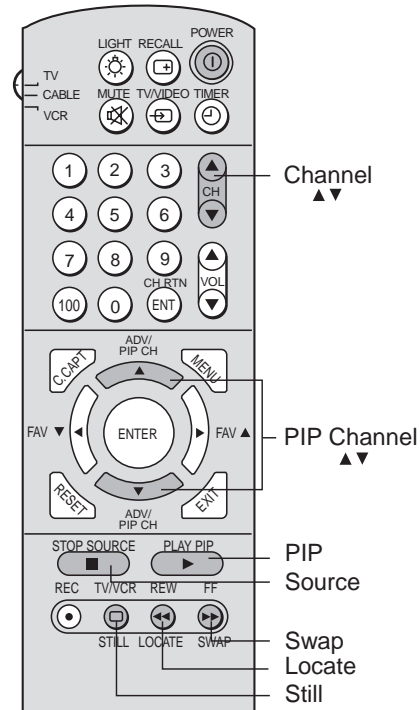
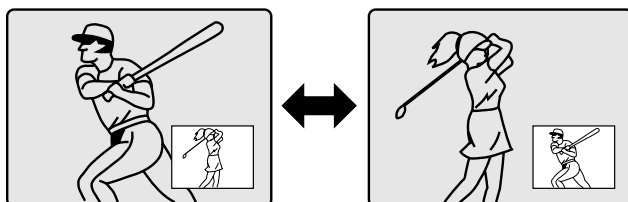

Note:

PIP cannot be turned on when the ColorStream input is being viewed.

You cannot display the signal sources input through the ANT-2 terminal as a small picture.

Changing the position of the small picture

With the TV in PIP mode, press LOCATE to change the display position of the small picture. Every time you press LOCATE, the small picture display changes position in a counter-clockwise manner.

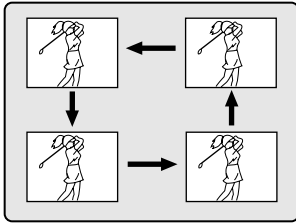

Freezing the small picture

With the TV in PIP mode, press STILL to freeze the small picture. The small picture becomes a still picture (outlined in red in the on-screen display). Press STILL again to return to the moving picture (outlined in green in the on-screen display).

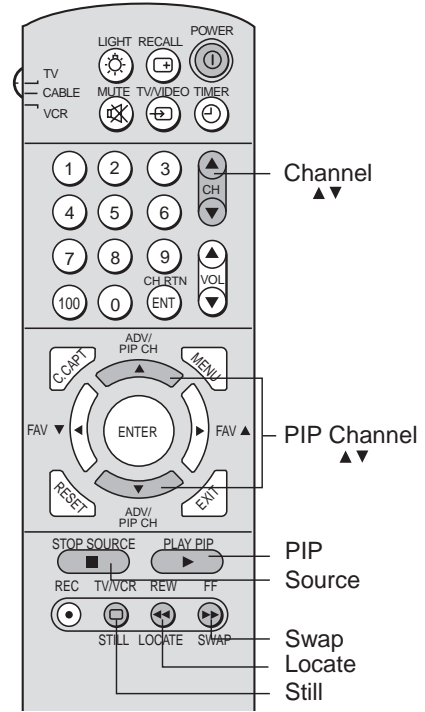
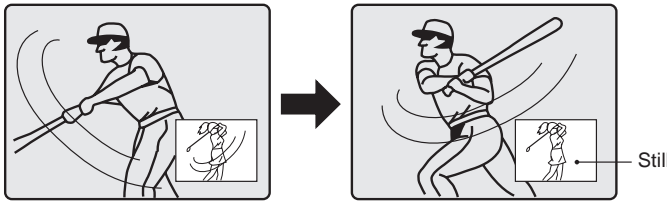

Watching multi-window PIP

Multi-window PIP appears as six small boxes across the bottom of the screen. Multi-window PIP cannot be viewed unless channels are programmed into the TV's memory (see "Adding channels to the TV's memory" on page 12).

Note: The LOCATE, SWAP, PIP CH ▲▼, SOURCE, and STILL buttons do not work in Multi-window PIP mode.

To view multi-window PIP:

Press PIP three times.

The TV cycles through the programmed channels and shows a few seconds of each channel's programming, then freezes the image and moves on to the next channel in a continuous cycle. The channel number appears above each small PIP window.

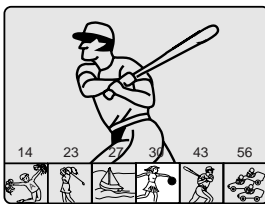

To turn multi-window PIP off:

Press PIP again or change the channel.

Note:

Multi-window PIP shows channels programmed for the signal source you are currently viewing (ANT-1 or Cable).

Adjusting the picture

Adjusting the picture quality

You can adjust the picture quality to your personal preferences, including the contrast, brightness, sharpness, color, and tint. Your picture quality adjustments are stored automatically in the TV's memory. You can keep these settings or choose preset options under the PREFERENCES menu. (See "Selecting the color temperature" below, and "Adjusting the picture preference" on the following page.)

To adjust the picture quality:

1. Press MENU.
2. Press ◀ or ▶ to highlight the PICTURE menu.
3. Press ▲ or ▼ until the quality you want to adjust is highlighted.

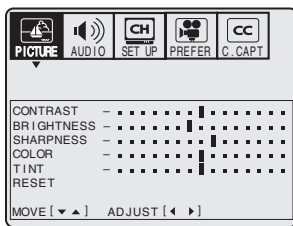

4. Press ◀ or ▶ to adjust the level.

Selection	◀ Pressing ▶	
Contrast	Lower	Higher
Brightness	Darker	Lighter
Sharpness	Softer	Sharper
Color	Paler	Deeper
Tint	Reddish	Greenish

Selecting the color temperature

You can change the quality of the picture by selecting from three preset color temperatures: cool, medium, and warm.

Mode	Picture Quality
Cool	Blueish
Medium	Neutral
Warm	Reddish

To select the color temperature:

1. Press MENU.
2. Press ◀ or ▶ to highlight the Preferences ("PREFER") menu.
3. Press ▲ or ▼ to highlight COLOR TEMPERATURE.
4. Press ◀ or ▶ to highlight the mode you prefer.

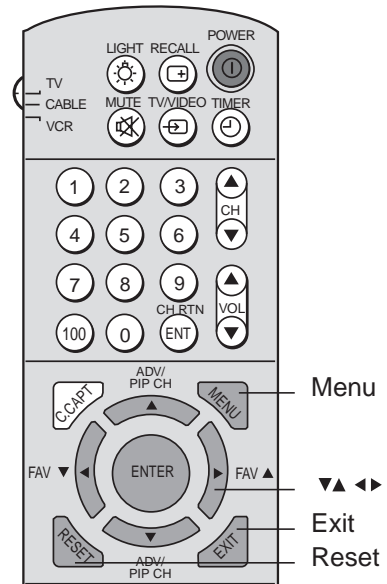
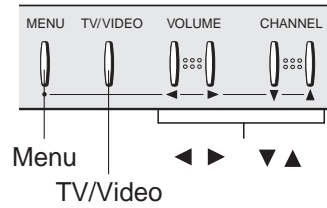

Note:

To reset the picture adjustments to the factory settings, select RESET from the PICTURE menu.

Adjusting the picture preference

You can select your desired picture type from four picture modes: Sports, Standard, Movie, and Memory, as described in the following table:

Mode	Picture Quality
Sports	Bright and dynamic picture (factory-set)
Standard	Standard picture quality (factory-set)
Movie	Movie-like picture setting (factory-set)
Memory	Your personal preferences (set by you; see "Adjusting the picture quality" on page 26.)

To select your picture preference:

1. Press MENU.
2. Press ◀ or ▶ to highlight the Preferences ("PREFER") menu.
3. Press ▲ or ▼ to highlight PICTURE PREFERENCES.
4. Press ◀ or ▶ to highlight the mode you prefer.

Watching video input

Press the TV/VIDEO button on the remote control or TV to view a signal coming from other devices connected to your TV, such as a VCR or video disc player (see "Connecting your TV" on page 2).

Displaying on-screen information

Press RECALL to display the following on-screen information:

- Antenna mode (when in TV mode)
- Channel number or video mode
- Channel label (if set)
- Audio status (stereo or SAP)
- Rating of current program (if rated)

Setting the off-timer

You can set the off-timer to turn the TV off automatically.

To set the off-timer:

1. Press TIMER.
2. Press ▶ to increase and ◀ to decrease the off time in 10-minute increments to a maximum of 180.
3. Press EXIT to exit the menu and return to normal TV viewing.

To cancel the off-timer:

Set the off-timer to 0 (zero) minutes, or turn the TV off and then on again.

Auto power off

The TV turns itself off automatically after approximately 15 minutes if it is tuned to a vacant channel or a station that stops broadcasting for the day.

Note: This feature does not work in Video mode.

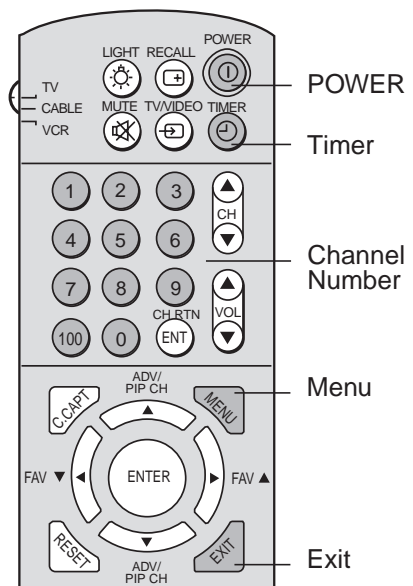
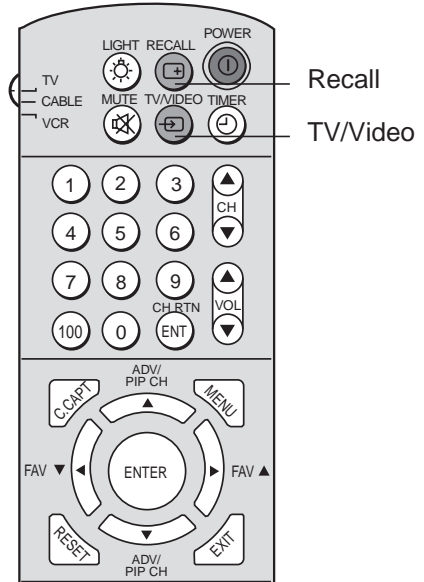
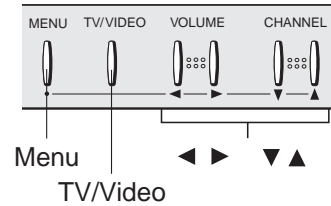

Using the closed caption feature

The Closed Caption feature has two options:

- **Captions**—An on-screen display of the dialogue, narration, and sound effects of programs and videos that are closed-captioned (usually identified in your local TV listing as “CC”).
- **Text**—An on-screen display of information not related to the program, such as weather or stock data (if available in your viewing area).

To view captions or text:

1. Tune the TV to the desired program or video.
2. Press MENU.
3. Press ◀ or ▶ to highlight the C.CAPT menu.
4. Press ▲ or ▼ to highlight CC.

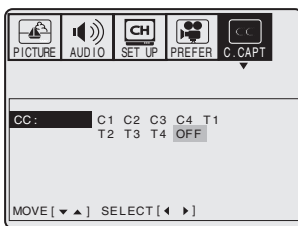

5. Press ◀ or ▶ to select the desired Closed Caption mode, as follows:

- To view captions, select C1, C2, C3, or C4 (C1 displays translation of the primary language in your area). **Note:** If the program or video you selected is not closed-captioned, no captions will display on the screen.



- To view text, select T1, T2, T3, or T4. **Note:** If text is not available in your viewing area, a black rectangle may appear on your screen. If this occurs, turn the Closed Caption feature off.

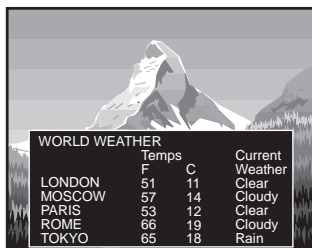

- To turn the Closed Caption feature off, highlight OFF in the Closed Captioning menu.

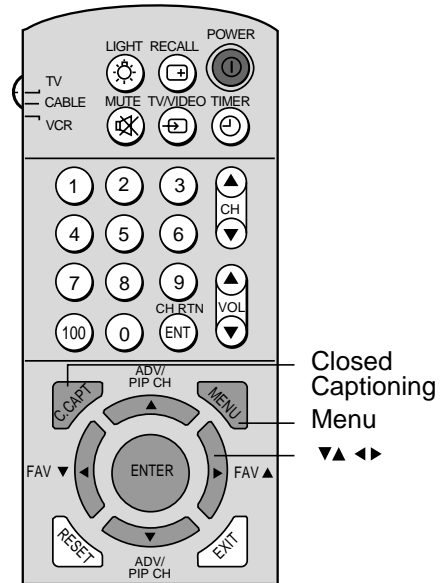

Note:

A closed caption signal may not display in the following situations:

- When a videotape has been dubbed
- When the signal reception is weak
- When the signal reception is non-standard

Adjusting the sound

Muting the sound

Press MUTE to temporarily turn the sound off. While the sound is off, the screen displays the word MUTE in the lower right corner. To restore the sound, press MUTE or VOL ▲▼.

When you press the MUTE button, the Closed Caption feature is automatically activated. To deactivate captions, press the MUTE button again. This feature works only when the Closed Caption mode is set to OFF. See “Using the closed captioned feature” on page 28 for more information about closed caption settings.

Selecting stereo/SAP broadcasts

Use the multi-channel TV sound (MTS) feature to listen to high-fidelity stereo sound while watching TV. MTS also can transmit a second audio program (SAP) containing a second language or other audio information. **Note:** The MTS feature is not available in Video mode.

In general, you can leave your TV in Stereo mode because the TV automatically outputs either stereo or monaural (“mono”) sound, depending on the broadcast type. If the stereo sound is noisy, select MONO to reduce the noise.

When the TV receives a stereo or SAP broadcast, the word “STEREO” or “SAP” displays on the screen every time you turn the TV on, change the channel, or press RECALL.

To listen to stereo sound:

1. Press MENU.
2. Press ◀ or ▶ to highlight the AUDIO menu.
3. Press ▲ or ▼ to highlight MTS.
4. Press ◀ or ▶ to highlight STR (stereo). The STR and SAP menu items display in yellow when the TV receives the signal (if available), and in purple when the feature is selected.

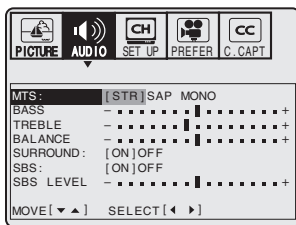

To listen to a second audio program:

1. Press MENU.
2. Press ◀ or ▶ to highlight the AUDIO menu.
3. Press ▲ or ▼ to highlight MTS.
4. Press ◀ or ▶ to highlight SAP. The TV speakers will output only the second audio program.

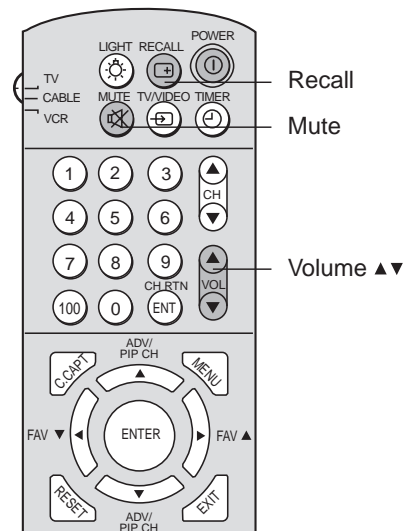
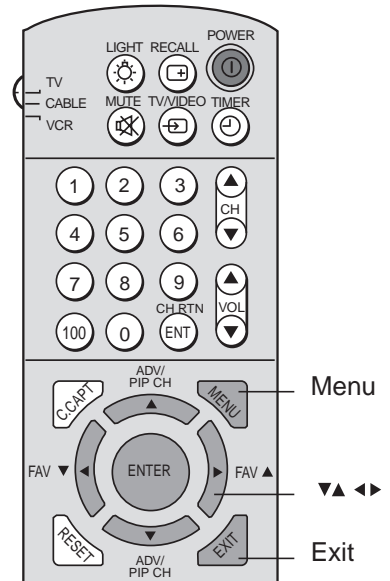

Adjusting the sound quality

You can change the sound quality of your TV by adjusting the bass, treble, and balance.

To adjust the sound quality:

1. Press MENU.
2. Press ◀ or ▶ to highlight the AUDIO menu.
3. Press ▲ or ▼ to highlight the quality you want to adjust.
4. Press ◀ or ▶ to adjust the level:
 - ◀ makes the sound quality weaker or decreases the balance in the right channel, depending on the item selected.
 - ▶ makes the sound quality stronger or decreases the balance in the left channel, depending on the item selected.

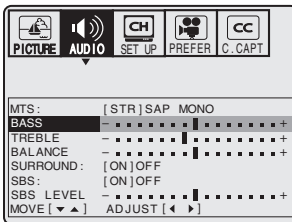

Using the surround sound feature

The surround sound feature expands the audio listening field wider and deeper to create exceptional sound quality from the TV speakers. This feature uses stereo signals from a TV broadcast or video input.

To turn the surround sound feature on:

1. If you have not already done so, select Stereo mode (see “Selecting stereo/SAP broadcasts” on the previous page).
2. Press MENU.
3. Press ◀ or ▶ to highlight the AUDIO menu.
4. Press ▲ or ▼ to highlight SURROUND.
5. Press ◀ or ▶ to highlight ON.

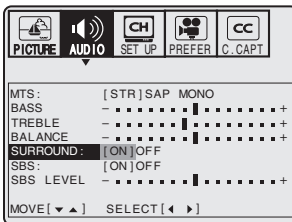

To turn the surround sound feature off:

Highlight OFF in step 5 above. **Note:** In general, you can leave the surround sound feature on because it automatically outputs surround stereo or monaural sound, depending on the broadcast or video type.

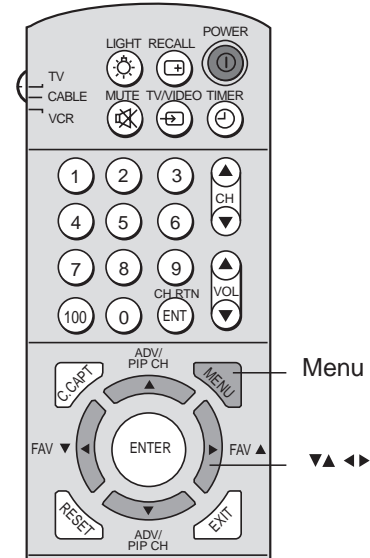
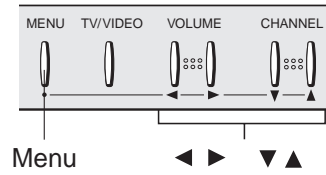

Note:

To reset the audio adjustments to the factory settings, select RESET from the PICTURE menu.

Using the sub-bass system (SBS)

The sub-bass system (SBS) allows you to enhance bass performance, even when the volume is low.

To turn the sub-bass system on [or off]:

1. Press MENU.
2. Press ◀ or ▶ to highlight the AUDIO menu.
3. Press ▲ or ▼ to highlight SBS.
4. Press ◀ or ▶ to highlight ON [or OFF].

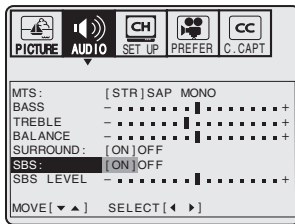

To adjust the sub-bass system:

1. Turn the sub-bass system on, as instructed above.
2. Press MENU.
3. Press ◀ or ▶ to highlight the AUDIO menu.
4. Press ▲ or ▼ to highlight SBS LEVEL.
5. Press ◀ or ▶ to adjust the SBS level.

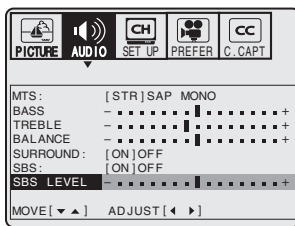

Viewing the demonstration (DEMO) mode

The demonstration (DEMO) mode is an option available on the SET UP menu that will demonstrate several features of your TV.

To start the demonstration mode:

1. Press MENU.
2. Press ◀ or ▶ to highlight the SET UP menu.
3. Press ▲ or ▼ to highlight DEMO.
4. Press ◀ or ▶ to start the demo.

To stop the demonstration mode:

Press RECALL, EXIT, or POWER.

Understanding the last mode memory feature

If the power is cut off while you are viewing the TV, the Last Mode Memory feature turns the TV on automatically when the power is resupplied.

If the power is going to be off for a long time and you are going to be away from your TV, unplug the power cord to prevent the TV from turning on in your absence.

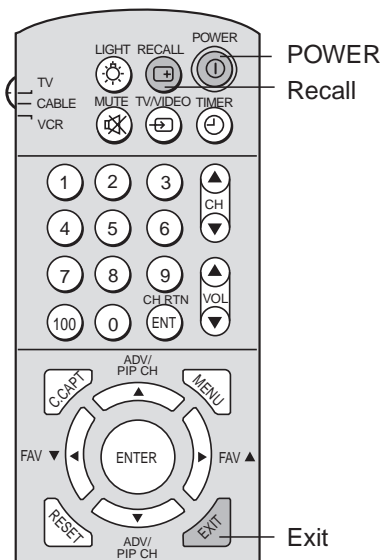
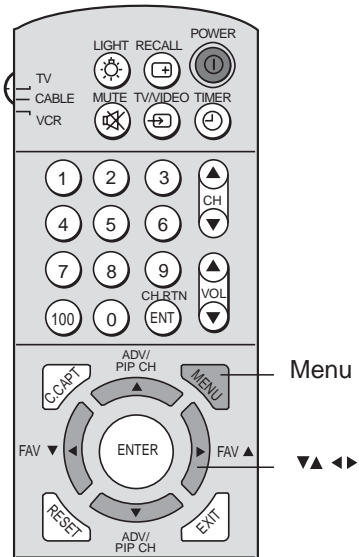
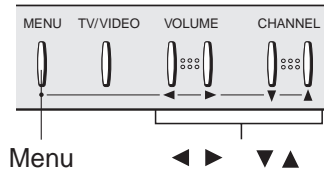

Appendix

Cleaning and care

**WARNING: TV sets use high voltage. Do not remove the cabinet back.
Refer all servicing to qualified service technicians.**

To clean the TV screen and cabinet:

1. Unplug the power cord to avoid possible shock hazard.
2. Use a clean cellulose sponge or chamois cloth dampened with a solution of mild detergent and warm water to clean the TV screen and trim. Do not use too much water; liquid spilling into the cabinet can damage the TV.
3. Wipe off excess moisture with a clean dry cloth.
4. Polish the cabinet with a quality furniture polish to maintain the finish and appearance of the cabinet.

Caution:

*Never use strong solvents such as thinner, benzene, or other chemicals on or near the cabinet.
These chemicals can damage the cabinet's finish.*

Troubleshooting

Before calling a service technician, please check the following table for possible causes of the problem and some solutions.

Problem	Solution
TV will not turn on	<ul style="list-style-type: none">• Make sure the power cord is plugged in, then press POWER.• The remote control batteries may be dead. Replace the batteries or press the POWER button on the TV.
No picture, no sound	<ul style="list-style-type: none">• Check the antenna/cable connections.
No sound, picture OK	<ul style="list-style-type: none">• The sound may be muted. Press MUTE or VOL ▲▼.• The station may have broadcast difficulties. Try another channel.
Poor sound, picture OK	<ul style="list-style-type: none">• The station may have broadcast difficulties. Try another channel.
Poor picture, sound OK	<ul style="list-style-type: none">• Check the antenna connections.• The station may have broadcast difficulties. Try another channel.• Adjust the PICTURE menu.
Poor reception of broadcast channels	<ul style="list-style-type: none">• The station may have broadcast difficulties. Try another channel.• Check the antenna connections.• If you are using a VCR, make sure the TV/VCR button is set correctly.
Cannot receive above channel 13	<ul style="list-style-type: none">• Make sure TV/CABLE is set to TV mode.
Unable to select a certain channel	<ul style="list-style-type: none">• The channel may be locked out with the channel lock feature, or erased with the add/erase feature.
Multiple images	<ul style="list-style-type: none">• The station may have broadcast difficulties. Try another channel.• Use a highly directional outdoor antenna.

- Poor color or no color
 - The station may have broadcast difficulties. Try another channel.
 - Adjust the TINT and/or COLOR in the PICTURE menu.
 - If you change the direction of the TV while it is turned on, the picture could suffer from color shading. If so, turn the TV off and allow it to cool down for several hours before turning it on again.
- No stereo or SAP sound from a known MTS broadcast
 - Make sure the MTS feature is set properly.
- The remote control does not operate
 - Check that the TV/CABLE/VCR switch is properly set.
 - There may be an obstruction between the remote control and the remote control sensor.
 - The remote control batteries may be dead. Replace the batteries.
- The V-Chip PIN code does not work
 - Change or reset your PIN code.

Specifications

Television system	NTSC standard	
Channel coverage	VHF: 2 through 13	UHF: 14 through 69
	Cable TV: Mid band (A-8 through A-1, A through 1) Super band (J through W) Hyper band (AA through ZZ, AAA, BBB) Ultra band (65 through 94, 100 through 125)	
Power source	120 AC, 60 Hz	
Power consumption	32AX60: 105 W; 36AX60: 105 W	
Audio power	5 W + 5 W	
Speaker type	2-3/8 x 4-3/4 inches (60 x 120 mm)	
Video/Audio terminals	S-VIDEO INPUT Y-INPUT: 1 V (p-p), 75 ohm, negative sync. C-INPUT: 0.286 V (p-p) (burst signal), 75 ohm	
	VIDEO/AUDIO INPUT VIDEO: 1 V (p-p), 75 ohm, negative sync. AUDIO: 150 mV (rms) (30% modulation equivalent, 47 k ohm)	
	VIDEO/AUDIO OUTPUT VIDEO: 1 V (p-p), 75 ohm, negative sync. AUDIO: 150 mV (rms) (30% modulation equivalent, 47 k ohm)	
Dimensions	<u>32AX60:</u>	<u>36AX60:</u>
	Width: 30-5/8 inches (778 mm)	34-9/16 inches (878 mm)
	Height: 27-5/16 inches (694 mm)	30-1/2 inches (775 mm)
	Depth: 22-11/16 inches (576 mm)	25-3/4 inches (654 mm)
Weight	32AX60: 123 lbs. (55.8 kg); 36AX60: 158 lbs. (71.7 kg)	
Supplied accessories	Remote control with two size "AA" batteries	
Optional TV stand	32AX60: ST-3230; 36AX60: ST-3615, ST-3640	

Design and specifications are subject to change without notice.

Limited United States warranty

Toshiba America Consumer Products, Inc. (“TACP”) and Toshiba Hawaii Inc. (“THI”) make the following limited warranties. These limited warranties extend to the original consumer purchaser or any person receiving this set as a gift from the original consumer purchaser and to no other purchaser or transferee.

Limited one-year warranty

TACP and THI warrant this product and its parts against defects in materials or workmanship for a period of one (1) year after the date of original retail purchase. During this period, TACP and THI will repair or replace a defective part, at their option, with a new or refurbished part, at no cost to you. Authorized TACP/THI service station personnel will come to your home when warranty service is required. Depending on the type of repair required, either the service will be performed in your home or the set will be taken to the authorized TACP/THI service station for repair and returned to your home at no cost to you.

Limited two-year warranty of picture tube

TACP and THI further warrant the picture tube in this product against defects in materials or workmanship for a period of two (2) years after the date of original retail purchase. During this period, TACP and THI will repair or replace a defective picture tube at their option, with a new or refurbished picture tube, at no cost to you, except that, if a defective picture tube is replaced after one (1) year from the date of the original retail purchase, you pay labor charges involved in the replacement.

Rental units

The warranty for rental units begins with the first rental or thirty (30) days from the date of shipment to the rental firm, whichever comes first.

Commercial units

Products sold and used for commercial use have a limited ninety (90) day warranty for the picture tube and all parts and labor.

Owner’s manual and registration card

You should read this owner’s manual thoroughly before operating this product. Complete and mail the enclosed registration card within ten days after you, or the person who has given you this product as a gift, purchased this product. This is one way to enable TACP/THI to provide you with better customer service and improved products. Failure to return the registration card will not affect your rights under this warranty.

Your responsibility

The above warranties are subject to the following conditions:

- You must retain your bill of sale or provide other proof of purchase.
- All warranty servicing of this product must be made by an Authorized TACP/THI Service Station.
- **These warranties are effective only if the product is purchased and operated in the U.S.A. or Puerto Rico.**
- Labor service charges for set installation, setup, adjustment of customer controls, and installation or repair of antenna systems are not covered by this warranty. Reception problems caused by inadequate antenna systems are your responsibility.
- Warranties extend only to defects in materials or workmanship as limited above, and do not extend to any product or parts that have been lost or discarded by you; to damage to products or parts caused by misuse, accident, Acts of God (such as lightning), fluctuations in electric power, improper installation, improper maintenance, or use in violation of instructions furnished by us; or to units that have been modified or had the serial number removed, altered, defaced, or rendered illegible.

How to obtain warranty service

If, after following all operating instructions in this manual and checking the section “Troubleshooting,” you find a that service is needed because of a defective product or part, call the TACP toll-free number **1-800-631-3811** to locate the nearest Toshiba Authorized Service Station. Please present your bill of sale or other proof to the authorized service personnel.

In the Continental U.S.

If your TV requires service, call toll free:
1-800-631-3811



In Hawaii

If your TV requires service, call:
(808) 591-8377
327 Kamakee Street, Honolulu, HI 96814

Limitations

All warranties implied by state law, including the implied warranties of merchantability and fitness for a particular purpose, are expressly limited to the duration of the limited warranties set forth above. With the exception of any warranties implied by state law as hereby limited, the foregoing warranty is exclusive and in lieu of all other warranties, guarantees, agreements and similar obligations of manufacturer or seller with respect to the repair or replacement of any parts. In no event shall TACP or THI be liable for consequential or incidental damages.

No person, agent, distributor, dealer, or company is authorized to change, modify, or extend the terms of these warranties in any manner whatsoever. The time within which action must be commenced to enforce any obligation of TACP or THI arising under this warranty or under any statute or law of the United States or any state thereof is hereby limited to 90 days from the date you discover or should have discovered the defect. This limitation does not apply to implied warranties arising under state law.

This warranty gives you specific legal rights. You also may have other rights, which may vary from state to state. Some states do not allow limitation on how long an implied warranty lasts, when an action may be brought, or the exclusion or limitation of incidental or consequential damages, so the above provisions may not apply to you.

Attention Canadian customers



Canadian consumers are requested to complete the special Canadian "Warranty Registration Form" enclosed, and forward this completed form with a copy of the bill of sale to TOSHIBA OF CANADA to "Register and Validate" their warranty.

Products purchased in the U.S.A. and used in Canada are not covered by these warranties.

Products purchased in Canada and used in the U.S.A. are not covered by these warranties.

Index

A

adding and erasing channels manually	13
adding channels to the TV's memory	12
adjusting	
channel settings	13
picture preference	27
picture quality	26
sound	29
antenna input, selecting	11
audio amplifier, connecting	6
auto power off	27

B

batteries, installing in the remote control	7
blocking	
channels	20
programs by ratings	17
unrated movies and programs	19

C

cable converter box and VCR, connecting	3
cable converter box, connecting	3
cable TV converter code table	9
camcorder, connecting	6
care and cleaning of your TV	32
changing	
channels	13
on-screen display language	11
position of the small picture (PIP)	25
channel settings, adjusting	13
channels	
adding and erasing manually	13
adding to the TV's memory	12
blocking with V-Chip	20
changing	13
favorite, programming	14
labels	22
programming automatically	12
switching between two	13
cleaning and care of your TV	32
closed caption feature, using	28
code table	
cable TV converter	9
VCR	8
ColorStream™ DVD and VCR, connecting	4
color temperature, selecting	26

connecting	
audio amplifier	6
cable converter box	3
cable converter box and VCR	3
camcorder	6
DVD with ColorStream™ and a VCR	4
DVD/satellite receiver and VCR	4
TV	2
VCR	2
VCRs, two	5

D

demonstration (DEMO) mode, viewing	31
displaying on-screen information	27
DVD with ColorStream and a VCR, connecting	4
DVD/satellite receiver and VCR, connecting	4

F

favorite channels, programming	14
freezing the small picture (PIP)	25

L

labels	
channel	22
video	23
language, changing the on-screen display	11
last mode memory feature, understanding	31
location for TV, selecting	1

M

MPAA ratings	17
multi-window PIP	25
muting the sound	29

O

off-timer, setting	27
on-screen display language, changing	11
on-screen information, displaying	27

P

picture	
adjusting	26
color temperature, selecting	26
preference, adjusting	27
quality, adjusting	26

picture-in-picture (PIP)		specifications	33
changing the position of the small picture	25	stereo sound, selecting	29
freezing the small picture	25	surround sound, using	30
main and small pictures, switching	24	switch, TV/CABLE/VCR	7
watching	24	switching between two channels	13
watching multi-window	25	switching the main and small pictures (PIP)	24
PIN code, selecting	15		
PIP (see "picture-in-picture")		T	
power, auto off	27	troubleshooting	32
programming		TV	
channels automatically	12	connecting	2
favorite channels	14	location, selecting	1
remote control for use with a VCR		ratings	17
or cable TV converter	8	setting up	11
programs, blocking with V-Chip	15	TV/CABLE/VCR switch	7
		TV/VIDEO button on the TV, using	12
R		V	
ratings		V-Chip	
blocking programs by	17	blocking channels	20
MPAA	17	blocking programs by ratings	17
TV	17	selecting a PIN code	15
unrated movies or programs	19	using	15
youth TV	17	VCR and cable converter box, connecting	3
remote control		VCR and DVD with ColorStream, connecting	4
batteries, installing	7	VCR and DVD/satellite receiver, connecting	4
learning about	10	VCR, connecting	2
preparing for use	7	VCRs, connecting two	5
programming for use with a VCR		video input, watching	27
or cable TV converter	8	video labels	23
using	7	video lock	21
using with a VCR or cable TV converter	7		
		W	
S		warranty	34
SAP, selecting	29	watching	
satellite receiver/DVD and VCR, connecting	4	multi-window picture-in-picture (PIP)	25
signal source, selecting	12	picture-in-picture (PIP)	24
sound		video input	27
adjusting	29		
muting	29	Y	
stereo/SAP broadcasts, selecting	29	youth TV ratings	17
sub-bass system (SBS), using	31		
surround, using	30		

**Toshiba America
Consumer Products, Inc.**

Head Office
82 Totowa Road
Wayne, NJ 07470

Factory Service Center
1420B Toshiba Drive
Lebanon, TN 37087

Toshiba Hawaii, Inc.

Head Office
327 Kamakee Street
Honolulu, HI 96814

Toshiba of Canada, Ltd.

Head Office
191 McNabb Street
Markham, Ontario L3R 8H2
Canada

Service Centers

Toronto
191 McNabb Street
Markham, Ontario L3R 8H2
Canada
Tel: (905) 470-5400

Montreal
1643 North Service Road
Trans-Canada Highway
Dorval, Quebec H9P 1J1
Canada
Tel: (514) 856-4100

Vancouver
22171 Fraserwood Way
Richmond, British Columbia V6W 1J5
Tel: (604) 303-2500

Manufactured by:

TOSHIBA

**Toshiba America
Consumer Products, Inc.**

PRINTED IN USA
(00-06)B

23563919B