



A Sierra Monitor Company

Driver Manual
(Supplement to the FieldServer Instruction Manual)

FS-8700-133 Genisys

APPLICABILITY & EFFECTIVITY

Effective for all systems manufactured after January 2009

Driver Version:	1.00
Document Revision:	3

TABLE OF CONTENTS

1	GENISYS DESCRIPTION	3
2	DRIVER SCOPE OF SUPPLY	3
2.1	Supplied by FieldServer Technologies for this driver.....	3
3	HARDWARE CONNECTIONS.....	4
4	CONFIGURING THE FIELDSEVER AS A GENISYS CLIENT	5
4.1	Data Arrays/Descriptors	5
4.2	Client Side Connection Descriptions.....	6
4.3	Client Side Node Descriptors	7
4.4	Client Side Map Descriptors.....	8
4.4.1	<i>FieldServer Related Map Descriptor Parameters.....</i>	<i>8</i>
4.4.2	<i>Driver Related Map Descriptor Parameters.....</i>	<i>8</i>
4.4.3	<i>Timing Parameters.....</i>	<i>8</i>
4.5	Map Descriptor Example: Read Indications.....	9
4.6	Map Descriptor Example: Write Controls.....	10
5	CONFIGURING THE FIELDSEVER AS A GENISYS SERVER	11
	APPENDIX A. ADVANCED TOPICS	12
	Appendix A.1. Storage Structure for Data Type Bit and Byte	12
	APPENDIX B. ERROR MESSAGES	13

1 GENISYS DESCRIPTION

The Genisys driver allows the transfer of data to and from devices over RS-232 Genisys protocol. Vital Harmon Logic Controller (VHLC) supports Genisys protocol. IM-188 VHLC GENISYS SOFTWARE MANUAL 100188-008 ABO.PDF is the basis of the Genisys driver. The FieldServer can be configured as a Client. Limited Server side functionality has been implemented for FieldServer's quality assurance requirements only.

Max Nodes Supported

FieldServer Mode	Nodes	Comments
Client	1	Only 1 virtual client per port allowed on multidrop systems.
Server	255	Maximum device addresses pollable by Client – protocol limitation.

2 DRIVER SCOPE OF SUPPLY

2.1 Supplied by FieldServer Technologies for this driver

FieldServer Technologies PART #	Description
FS-8915-10	UTP cable (7 foot) for RS-232 use
FS-8917-04	RJ45 to DB25F connector adapter
FS-8700-133	Driver Manual.

3 HARDWARE CONNECTIONS

The FieldServer is connected to the VHLC as shown in the following connection drawing.

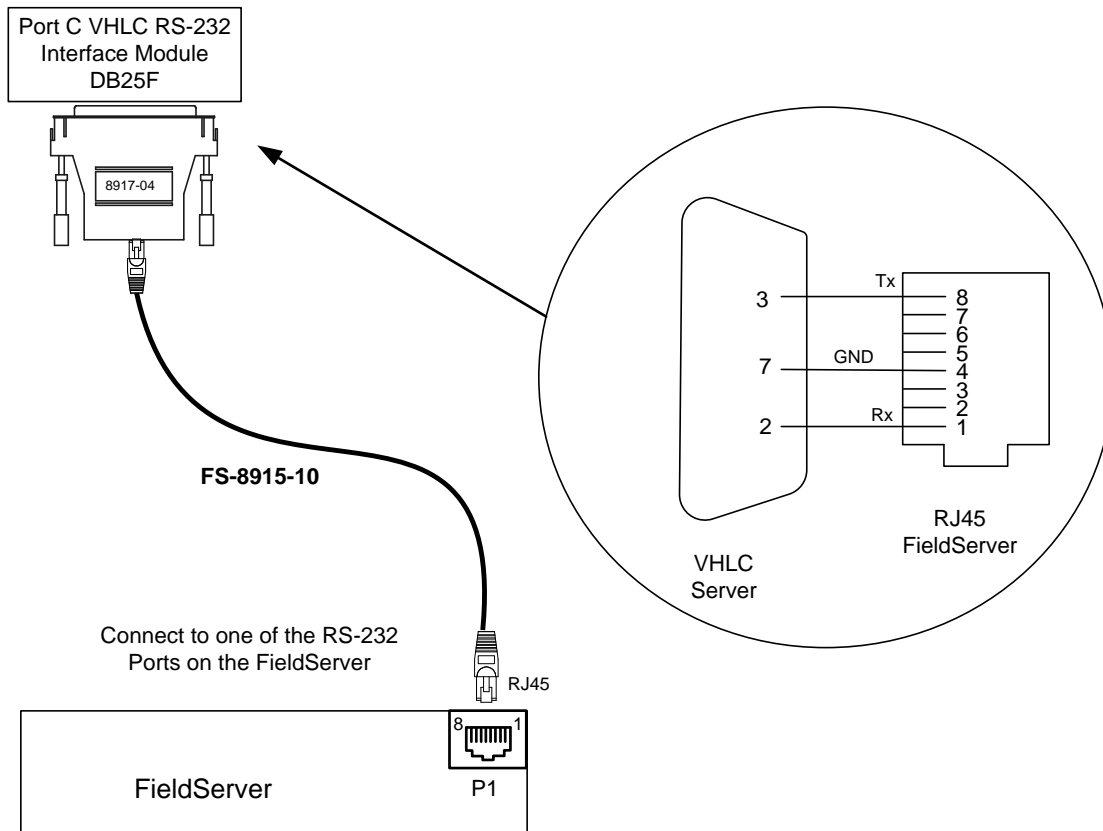

4 CONFIGURING THE FIELDSEVER AS A GENISYS CLIENT

For a detailed discussion on FieldServer configuration, please refer to the FieldServer Configuration Manual. The information that follows describes how to expand upon the factory defaults provided in the configuration files included with the FieldServer (See “.csv” sample files provided with the FieldServer).

This section documents and describes the parameters necessary for configuring the FieldServer to communicate with a Genisys Server.

4.1 Data Arrays/Descriptors

The configuration file tells the FieldServer about its interfaces, and the routing of data required. In order to enable the FieldServer for Genisys communications, the driver independent FieldServer buffers need to be declared in the “Data Arrays” section, the destination device addresses need to be declared in the “Client Side Nodes” section, and the data required from the Servers needs to be mapped in the “Client Side Map Descriptors” section. Details on how to do this can be found below.

Note that in the tables, * indicates an optional parameter, with the bold legal value being the default.

Section Title		
Data_Arrays		
Column Title	Function	Legal Values
Data_Array_Name	Provide name for Data Array	Up to 15 alphanumeric characters
Data_Array_Format	Provide data format. Each Data Array can only take on one format.	Float, Bit, UInt16, Sint16, Byte,
Data_Array_Length	Number of Data Objects. Must be larger than the data storage area required by the Map Descriptors for the data being placed in this array.	1-10,000

Example

```
// Data Arrays

Data_Arrays
Data_Array_Name ,Data_Array_Format ,Data_Array_Length
DA_8I_01        ,Byte                ,32
DA_8O_01        ,Byte                ,32
DA_DI_01        ,Bit                 ,256
DA_DO_01        ,Bit                 ,256
DA_COS_01       ,Byte                ,1
DA_COS_02       ,Byte                ,1
```

4.2 Client Side Connection Descriptions

Section Title		
Connections		
Column Title	Function	Legal Values
Port	Specify which port the device is connected to the FieldServer	P1-P8 ¹
Protocol	Specify protocol used	Genisys
Baud*	Specify baud rate	300 ,600, 1200, 2400, 4800, 9600 (Vendor limitation)
Parity*	Specify parity	None , Even, Odd (Vendor limitation)
Data_Bits*	Specify data bits	8 (Vendor limitation)
Stop_Bits*	Specify stop bits	1, 2 (Vendor limitation)
Handshaking*	Specify hardware handshaking	None
Poll_Delay*	Time between internal polls	0-32000 seconds, 0.05 seconds

Example

```
//
// Client Side Connections
//
Connections
Port ,Baud ,Data_Bits ,Stop_Bits ,Parity ,Protocol
P1 ,9600 ,8 ,1 ,None ,Genisys
```

¹ Not all ports shown are necessarily supported by the hardware. Consult the appropriate Instruction manual for details of the ports available on specific hardware.

4.3 Client Side Node Descriptors

Section Title		
Nodes		
Column Title	Function	Legal Values
Node_Name	Provide name for Node	Up to 32 alphanumeric characters
Node_ID	VHLC station address of physical Server Node	1-255
Protocol	Specify protocol used	Genisys
Connection	Specify which port the device is connected to the FieldServer	P1-P8 ¹
Genisys_Check_Controls*	If OFF, the FieldServer configures VHLC to apply controls from the FieldServer without verification. If ON, the FieldServer configures VHLC to verify controls supplied by the FieldServer before applying.	OFF, ON
Genisys_Intra_Poll_Delay*	Specify time, that FieldServer should wait before sending ACK or Execute message after receiving the last character of response from VHLC.	0.010s, 0.025s etc

Example

```
// Client Side Nodes
//
Nodes
Node_Name ,Node_ID ,Protocol ,Port ,Genisys_Check_Controls ,Genisys_Intra_Poll_Delay
Genisys_01 ,1 ,Genisys ,P1 ,ON ,0.01s
Genisys_02 ,2 ,Genisys ,P1 ,-,0.01s
```

4.4 Client Side Map Descriptors

4.4.1 FieldServer Related Map Descriptor Parameters

Column Title	Function	Legal Values
Map_Descriptor_Name	Name of this Map Descriptor	Up to 32 alphanumeric characters
Data_Array_Name	Name of Data Array where data is to be stored in the FieldServer	One of the Data Array names from "Data Array" section above
Data_Array_Offset	Starting location in Data Array	0 to maximum specified in "Data Array" section above
Function	Function of Client Map Descriptor	COS_Poller, COS_Read , Wrbx

4.4.2 Driver Related Map Descriptor Parameters

Column Title	Function	Legal Values
Node_Name	Name of Node to fetch data from	One of the Node names specified in "Client Node Descriptor" above
Data_Type*	'Bit' each byte of Indication statuses will be stored in 8 consecutive locations in the Data Array. Similarly while writing; Control byte will be composed from 8 consecutive locations of the Dara Array. 'Byte' each byte of Indication statuses will be stored as an 8-Bit Integer at the specified location. Similarly while writing; Control byte will be composed from a single location of the Data Array. Refer to Appendix A.1	Bit, Byte
Address*	Internally used parameter, if used specify value 0	0
Length*	Length of Map Descriptor Number of indications to store or number of controls to write as per Data_Type.	Bit: 1-256, 8 Byte: 1-32, 1

4.4.3 Timing Parameters

Column Title	Function	Legal Values
Scan_Interval	Rate at which data is polled	≥0.001s

4.5 Map Descriptor Example: Read Indications

The following Map Descriptors will read indication words from physical Server Genisys_01 and Genisys_02 (described in Client Side Node Descriptors section).

The Cos_Poller Map Descriptor polls VHLC for any indication word changes and returned data is stored on the Data Array under the COS_READ Map Descriptor for the same Node. The rate of polling is determined by the Scan_Interval.

The Cos_Read Map Descriptor also polls VHLC for all indication words irrespective of data change. The rate of polling is determined by the Scan_Interval.

If Data_Type is Byte, any location in Data Array will hold one indication word from VHLC.

If Data_Type is Bit, eight consecutive locations in Data Array will hold one indication word from VHLC. Also see Appendix A.1.

```
// Client Side Map Descriptors
//
Map_Descriptors
Map_Descriptor_Name ,Scan_Interval ,Data_Array_Name ,Data_Array_Offset ,Function ,Node_Name ,Data_Type ,Address ,Length
CMD_01 ,1.00s ,DA_COS_01 ,0 ,COS_Poller ,Genisys_01 ,Byte ,0 ,1
CMD_01a ,50s ,DA_8I_01 ,0 ,COS_Read ,Genisys_01 ,Byte ,0 ,32

CMD_02 ,1.00s ,DA_COS_02 ,0 ,COS_Poller ,Genisys_02 ,Bit ,0 ,1
CMD_02a ,50s ,DA_DI_01 ,0 ,COS_Read ,Genisys_02 ,Bit ,0 ,256
```

Frequency (in seconds) to read Indication Statuses

Name of one of the Data Arrays defined in the Data_Array section. Indication statuses will be stored in this Data Array

Starting offset in Data Array to hold 1st indication status

One of the Nodes declared in Node Section. Indications will be read from the station address

Number of consecutive locations in the Data array to be used for storing data from the Server.

4.6 Map Descriptor Example: Write Controls

The following Map Descriptor will write controls to physical Server Genisys_01 and Genisys_02 (described in Client Side Node Descriptors section) whenever any of the control statuses changes/updates. One such Map Descriptor is required per Node.

If Data_Type is Byte, 32 consecutive locations from the Data Array will be written to VHLC. Data at any location would be considered as one control word.

If Data_Type is Bit, 256 consecutive locations from the Data Array will be written to VHLC. Data at 8 consecutive locations would be considered as one control word.

Also see Appendix A.1.

```
// Client Side Map Descriptors
//
Map_Descriptors
Map_Descriptor_Name ,Scan_Interval ,Data_Array_Name ,Data_Array_Offset ,Function ,Node_Name ,Data_Type ,Address ,Length
CMD_01b ,-, ,DA_8O_01 ,0 ,Wrbx ,Genisys_01 ,Byte ,0 ,32
CMD_02 ,-, ,DA_DO_01 ,0 ,Wrbx ,Genisys_02 ,Bit ,0 ,256
```

Name of one of the Data Arrays defined in Data_Array section. This Data Array holds control statuses to be written to other devices.

Starting offset in the Data Array which holds the 1st control status.

Wrbx: send write command to the Server when the associated Controls updates or changes. To write continuously use Wrbx as the function and add a Scan_Interval parameter to configure how often to write.

One of the Nodes declared in the Node Section. Indications will read from the station address belonging to this Node

Number of consecutive locations in the Data array to use when issuing the Write command.

5 CONFIGURING THE FIELDSEVER AS A GENISYS SERVER

The Server side has been implemented only for FieldServer's quality assurance requirements.

Appendix A. Advanced Topics

Appendix A.1. Storage Structure for Data Type Bit and Byte

- LSB bit in Indication/Control Byte is the 1st status/control value
- If the Data_Type is 'Byte' and only the 1st and 2nd indication status values are 1 (out of 8 statuses), all others being zero, the Driver will store a numeric value of 3 in the Data Array.

Appendix B. Error Messages

Most error messages are associated with errors in parsing an incoming message from the VHLC panel. The most likely cause is a mismatch in expected message format. The driver will flag one of the following error messages and continue. In most cases the message currently being processed by the driver will also be printed so that any problems can be easily diagnosed.

The following Error Messages appear upon the 'Driver Messages' Screen

- %d means numeric number
- %s means string

Messages number 2, 3 and 11 will be displayed just once if generated after rebooting or power cycling the FieldServer.

Error	Description	Action
GENISYS:#1 FYI. Connection params are %d %d %d Even	If a connection is declared in section 4.2 without Baud, Data_Bits, Stop_Bits or Parity, the displayed parameter values will be in use.	Check if connection parameter matches the setting at VHLC.
GENISYS:#2 FYI. MD required to store data from Node(%d)	A Map Descriptor with function COS_Poller has been declared for a Node but the COS_Read Map Descriptor required to store the data is missing.	Edit configuration file and add Map Descriptor with COS_Read function.
GENISYS:#3 FYI. MD(%s) length required=%d, now Only %d statuses will be stored	The COS_Read Map Descriptor is of insufficient length to store all indication words from VHLC.	If all indication words need to be stored, edit the configuration file and change the length of the Map Descriptor to the reported value.
GENISYS:#4 ERR %dth word number %d is invalid	The indication data response from VHLC contains an invalid word number. Valid range is 0-31 No data will be stored.	Call tech support.
GENISYS:#5 FYI. Indications can not be written	The FieldServer received an instruction from a Server device to write indications to VHLC. FieldServer can only write controls to VHLC.	Inspect the configuration file to determine whether the Data Array under the COS_Poller or COS_Read Map Descriptor is mapped to receive write commands from other protocols. Also check that other devices are not configured to write data to these Data Arrays.
GENISYS:#11FYI. MD(%s) length required=%d, now Only %d statuses will be stored	The Driver is acting as a Server rather than a Client.	Call tech support.
GENISYS:#12 ERR %dth word number %d is invalid	The Driver is acting as a Server rather than a Client.	Call tech support.