



# VIB3870-1, VIB3870-2, VIB3870-3

Single, Double, Triple  
In-Vent® Hood System



**OPTIONS AND ACCESSORIES**  
(AT ADDITIONAL CHARGE)

- Installation

Project \_\_\_\_\_

Item No. \_\_\_\_\_

Quantity \_\_\_\_\_

In-Vent® conveyor oven ventilation hood system.  
All data is shown per oven section, unless otherwise indicated.

### EXTERIOR CONSTRUCTION

- Stainless steel exterior on front, sides, and ducts
- Integral exhaust and make-up air plenum and duct collar assembly
- Quick release duct fittings and duct extensions
- Front air make-up cooling panels
- Cooling fan motor exhaust plenum
- Conveyor entrance/exit end exhaust plenums
- Heat shields over end exhaust plenums and vertical exhaust corner riser
- Stainless steel ceiling trim pieces included

### INTERIOR CONSTRUCTION

- Aluminized steel, 300 and/or 400 series stainless steel
- Insulated supply ducting

### OPERATION

- Captures smoke, contaminants and cooking by-products emanating from the oven.
- Minimizes amount of tempered air removed from kitchen by surrounding itself and oven with a layer of untempered make-up air.
- Requires much less exhaust and make-up air flow than conventional overhead hoods.
- Exhausts grease and smoke from directly over conveyors resulting in cleaner oven and environment.
- Cooler surfaces lower radiant heat to room and increase operator safety and comfort significantly

### STANDARD FEATURES

- Available in three configurations
  - VIB3870-1 for single MT3870 oven
  - VIB3870-2 for double stacked MT3870 ovens
  - VIB3870-3 for triple stacked MT3870 ovens
- Fully detachable panels without tools
- Quick disconnect ducting for servicing or cleaning
- Adds only 4" to front-to-back dimensions
- Ventilation system controls can be interlocked with the oven's controls
- Modular design for easier handling and cleaning



In-Vent® Model VIB3870-1, VIB3870-2, VIB3870-3 for Blodgett Conveyor Oven MT3870

### BLODGETT OVEN COMPANY

[www.blodgett.com](http://www.blodgett.com)

1400 Toastmaster Drive, Elgin, IL USA 60120 • Phone: (847) 741-3300 • Fax: (847) 741-0015



# VIB3870-1, VIB3870-2, VIB3870-3

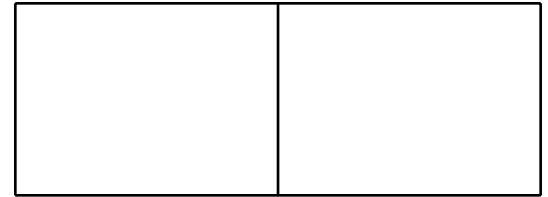

APPROVAL/STAMP

\*Ductwork should be terminated 99" (2515mm) above the finished floor (2" (51mm) above an 8' ceiling). All other connections will be supplied with the hood.

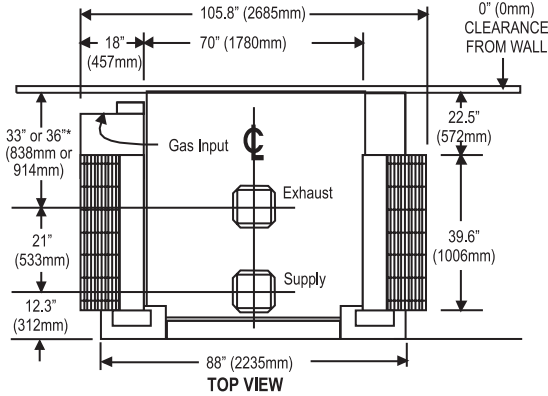

\* 36" (914mm) for VIB3870-3, 33" (838mm) for VIB3870-1 or VIB3870-2.

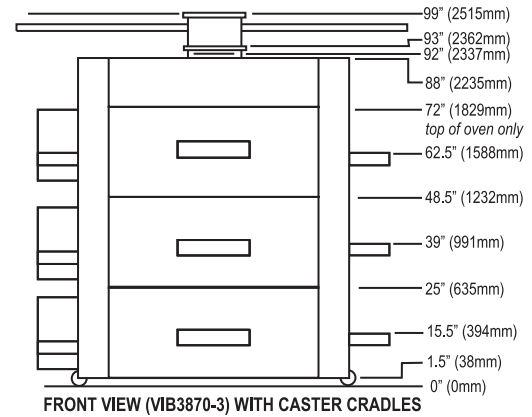
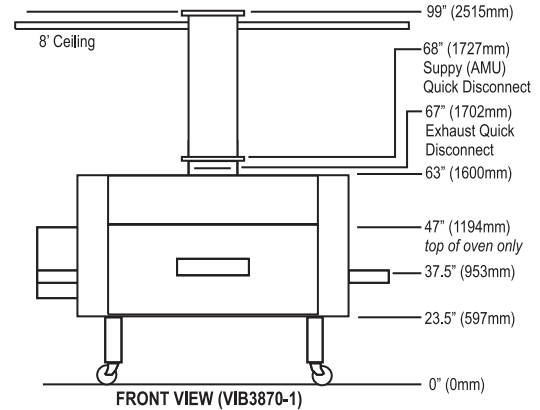
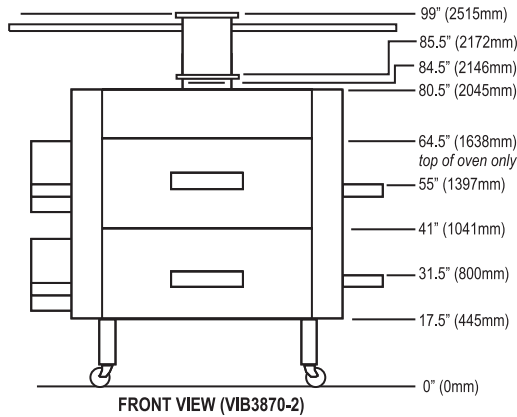

## SHORT FORM SPECIFICATIONS

Universal specification, based on specification sheet for specific system with specific oven model.

**SYSTEM**  
VIB3870-1, VIB3870-2, VIB3870-3

**OVEN MODEL**  
MT3870

Provide Blodgett In-Vent® ventilation system, engineered for Blodgett model MT3870 conveyor oven. Exterior shall be stainless steel on front sides and ducts. Interior shall be of aluminized steel. Baffle grease filters shall be of galvanized steel or aluminum construction. All exterior panels removable without the use of tools for access to mechanicals and cleaning. Integral exhaust and make-up air plenums connected to stainless steel duct collars with quick disconnect assemblies. Ventilation system shall comply with ANSI/NSF-2 and UL-710. Provide factory authorized assembly and installation at additional cost, per ANSI/NFPA-96. Ductwork between extension duct collars and rooftop equipment, and rooftop equipment not included.

## DIMENSIONS:

**Floor space** 105.8" (2685mm) W x 68" (1727mm) D

## AIRFLOW REQUIREMENTS:

Model	Supply	Exhaust
Duct Size (all models): 12" x 12" (305mm x 305mm)		
<b>VIB3870-1:</b>		
CFM:	1100 CFM	1500 CFM
Static Pressure:	0.02-0.03" W.C. (5-7 Pa)	1.5" W.C. (373 Pa)
<b>VIB3870-2:</b>		
CFM:	1450 CFM	1850 CFM
Static Pressure:	0.09" W.C. (22 Pa)	1.4" W.C. (348 Pa)
<b>VIB3870-3:</b>		
CFM:	1800 CFM	2200 CFM
Static Pressure:	0.12" W.C. (30 Pa)	1.8" W.C. (448 Pa)

**NOTE:** The company reserves the right to make substitutions of components without prior notice

## MINIMUM ENTRY CLEARANCE:

Largest uncrated component  
70" x 46.3" x 20" (1778mm x 1176mm x 508mm)

## SHIPPING INFORMATION:

Weight:	
VIB3870-1	380 lbs. (172 kg)
VIB3870-2	480 lbs. (218 kg)
VIB3870-3	580 lbs. (263kg)
Crate size:	
VIB3870-1	Palletized size and number not yet finalized
VIB3870-2	Palletized size and number not yet finalized
VIB3870-3	Palletized size and number not yet finalized

## BLODGETT OVEN COMPANY

www.blodgett.com

1400 Toastmaster Drive, Elgin, IL USA 60120 • Phone: (847) 741-3300 • Fax: (847) 741-0015