



KICKER[®]
MULTI-CHANNEL AMPLIFIER
with a CLASS-D SUBWOOFER CHANNEL

ZX550.3, ZX700.5

Multi-Channel Models: **ZX550.3 / ZX700.5**

Congratulations on your KICKER purchase

Please record your purchase information and keep your sales receipt for validation of warranty.

Authorized Kicker Dealer: _____
 Purchase Date: _____
 Amplifier Model Number: _____
 Amplifier Serial Number: _____

Installation . . . as easy as 1, 2, 3

1. Mounting Choose a structurally sound location to mount your Kicker amplifier. The controls on the top of the amplifier need to be accessible for adjustment. Make sure there are no items behind the area where the screws will be driven. Choose a location that allows at least 4" (10cm) of open ventilation for the amplifier. If possible, mount the amplifier in the climate-controlled passenger compartment. Drill four holes using a 7/64" (3mm) bit and use the supplied #8 screws to mount the amplifier.

2. Wiring Disconnect the vehicle's battery to avoid an electrical short. Then connect the ground wire to the amplifier. Make the ground wire short, 24" (60cm) or less, and connect it to a paint-and corrosion-free solid-metal area of the vehicle's chassis. Adding an additional ground wire between the battery's negative post and the vehicle chassis of this same gauge (or larger) is recommended.

Use a twisted pair(s) of RCA (low-level) interconnect cable to feed the audio signal to the amplifier. If you are using only one pair of RCA inputs, connect the RCA cable to the AMP 1 inputs. All three (or five ZX700.5) channels will work with a single pair of RCA input cable; the fader will not operate. Keep the RCA cable away from factory wiring harnesses and other power wiring. If you need to cross this wiring, cross it at a 90 degree angle.

Only use speaker wire (high-level) inputs if your source unit does not have RCA type outputs. When using both sets of high-level inputs for the ZX700.5, the supplied RCA dummy plugs must be inserted into the RCA AMP 2 inputs in order for the fader to work properly. In any other configuration do not use the RCA dummy plugs. Never use shorting plugs in any configuration. See Figure 1.

Install a fuse within 18" (45cm) of the battery and in-line with the power cable connected to your amplifier. If you ever need to remove the amplifier from the vehicle after it has been installed, the ground wire should be the last wire disconnected from the amplifier—just the opposite as when you installed it. See the chart below for power and ground wire size, and fusing recommendations.

Model ZX550.3	Fuse 60A	Power Ground Wire 4GA
Model ZX700.5	Fuse 90A	Power Ground Wire 4GA

3. Configuration The following diagrams show the most common configurations for your Kicker ZX series amplifier.

Four (ZX700.5) / Two Channel (ZX550.3) Operation with Subwoofer These ZX amplifiers are capable of operating into a minimum impedance of 2 ohms per channel in stereo operation and 2 ohms mono in the subwoofer channel. See Figure 3.

Bridged (Mono) Operation (ZX700.5) The ZX700.5 series amplifier is capable of operating into a minimum impedance of 4 ohms when in bridged operation. This allows you to bridge AMP 1 to run the "right" side and AMP 2 to run the "left" side. You will need two RCA Y-Adapters for this configuration. Each AMP is stable down to 4 ohms in this configuration. See Figure 4.

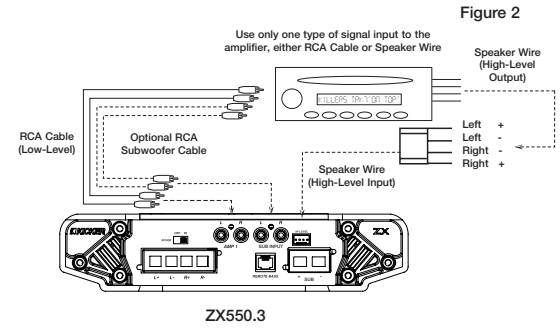

Figure 2

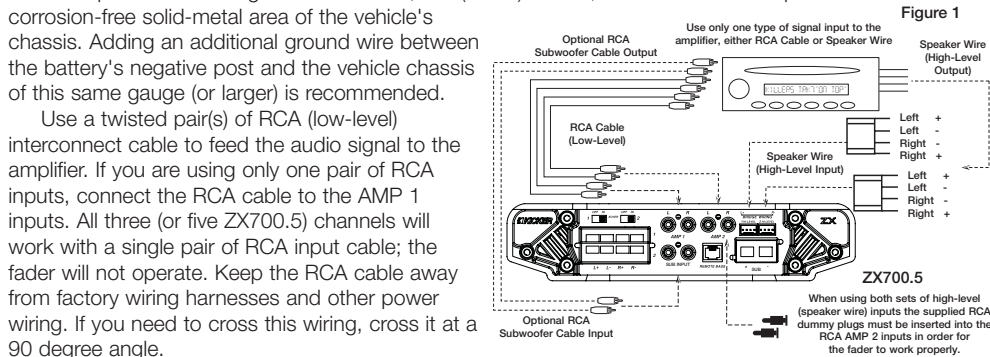

Figure 1

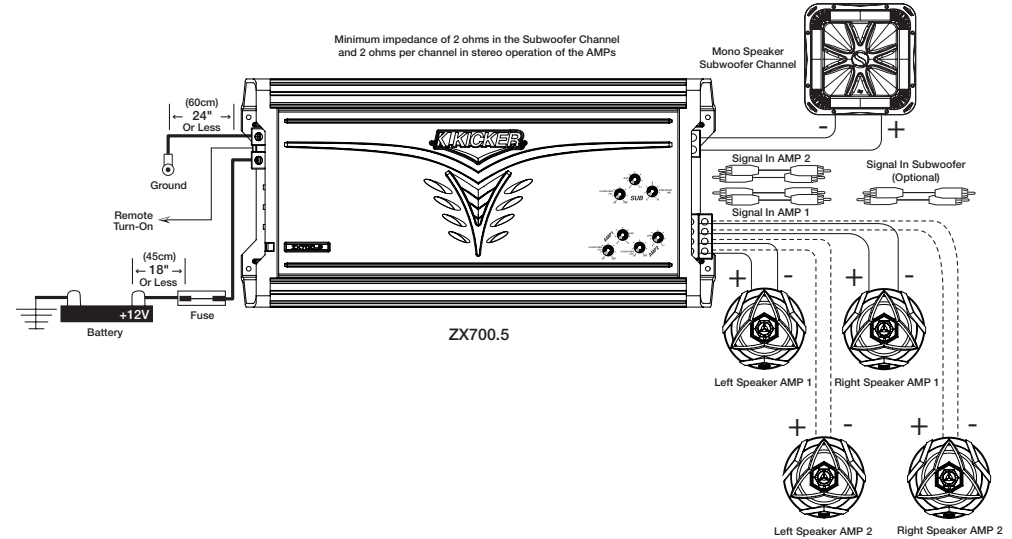

Figure 3

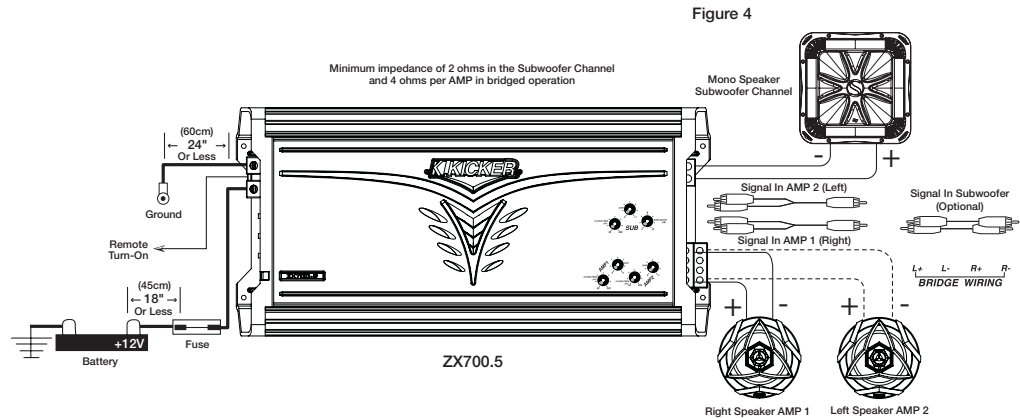

Figure 4

Operation

Your Kicker ZX series amplifier has five (or seven ZX700.5) rotary controls on top and one (or two ZX700.5) switch(es) on the end-panel. Before turning on the system for the first time, turn the rotary controls on the top of the amplifier to the full counter-clockwise position.

1. CrossoverSwitch The crossover switch(es) on the end-panel is (are) for setting the internal crossover(s) for the "full-range" audio channels (12dB slope per octave). In the OFF position the amplifier passes a full-range signal to the speakers. The HI position should be selected when connected to speakers, which you do not want to receive any sub-bass information. Never change the crossover "OFF/HI" switch setting with the audio system on!

2. InputGainControl The input gain control is not a volume control. It matches the output of the source unit to the input level of the amplifier. Turn the source unit up to about 3/4 volume (if the source unit goes to 30, turn it to 25). Next, slowly turn (clockwise) the gain on the amplifier up until you can hear audible distortion, then turn it down a little. Set AMP 1 first, then AMP 2 (ZX700.5 only) and finally the Subwoofer Channel input gain control.

3. BassBoostControl The bass boost control is designed to give you increased output 0 - 18dB at 40Hz for the subwoofer channel. The setting for this control is subjective. If you turn it up, you must go back and adjust the input gain control to avoid clipping the amplifier.

4. CrossoverControl The setting for this control is subjective; 80Hz is a good place to start.

5. RemoteBass(Level Control) When using the remote bass level control you have the ability to control the level of the Subwoofer Channel's output remotely. To mount the remote bass level control, simply screw the metal bracket to the chosen location. Then slide the housing onto the bracket until it snaps into place. Run the cable from the controller to the "Remote Bass" jack on the amplifier chassis.

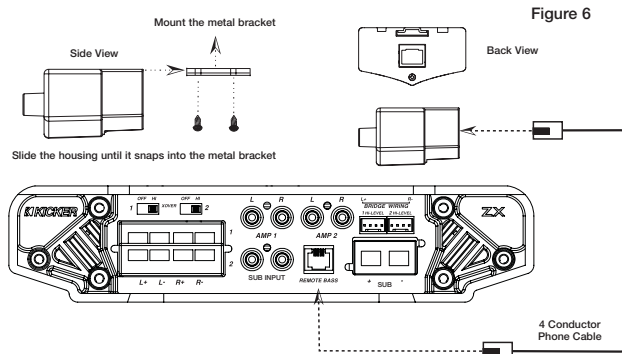

Troubleshooting

If your amplifier does not appear to be working, check the obvious things first such as blown fuses, poor or incorrect wiring connections, incorrect setting of crossover switch and gain controls, etc. There are two LEDs on the top of your Kicker ZX series amplifier, one green and one red. When the green LED is lit this indicates the amplifier is turned on and no trouble exists. If the green LED turns off and the red LED is lit, this indicates that the protection circuitry (SORT) is engaged.

Green LED off, no output? With a Volt Ohm Meter (VOM) check the following: 1) +12 volt power terminal (should read +12V to +16V) 2) Remote turn-on terminal (should read +12V to +16V) 3) Check for reversed power and ground connections 4) Ground terminal, for proper conductivity

Green LED on, no output? Check the following: 1) RCA connections 2) Test speaker outputs with a "known" good speaker. 3) Substitute source unit with a "known" good source unit. 4) Check for a signal in the RCA cable feeding the amplifier with the "AC" test position selected on the VOM meter.

Red LED on, no output? 1) Amplifier is very hot. ⇒Thermal protection is engaged. Test for proper impedance at the speaker terminals with a VOM meter (see the diagrams in this manual for minimum recommended impedance and multiple speaker wiring suggestions). Also check for adequate airflow around the amplifier. 2) Amplifier shuts down only while vehicle is running. ⇒Voltage protection circuitry is engaged. Voltage to the amplifier is not within the 9-16 volt operating range. Have the vehicle's charging and electrical system inspected. 3) Amplifier will only play at low

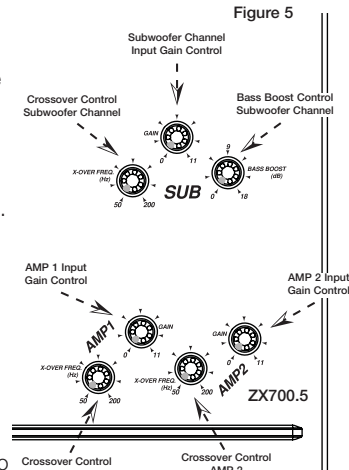

volume levels. ⇒Short circuit protection is engaged. Check for speaker wires shorted to each other or to the vehicle chassis. Check for damaged speakers, or speaker(s) operating below the minimum recommended impedance.

No output from one channel? 1) Check the balance control on source unit 2) Check the RCA (or speaker input) and speaker output connections for the channel 3) Swap the RCA (or speaker input) cable from left to right. *If the problem changes sides then you have a bad RCA (or speaker input) cable or source unit problem.* 4) Swap the speaker output wire from left to right. *If the problem changes sides then you have a bad speaker cable, passive crossover network and/or speaker.*

Alternator noise-whining sound with engine's RPM? 1) Check for damaged RCA (or speaker input) cable 2) Check the routing of RCA (or speaker input) cable 3) Check the source unit for proper grounding 4) Check the gain settings and turn them down if they are set too high

Poor stereo image or reduced bass response? ⇒Check system phasing by turning the balance control from left to right. If there is more bass output when turned to either side, then check your speaker wiring, passive crossover networks and speaker terminals for proper positive and negative connections. Reverse a speaker connection from positive to negative on the stereo/subwoofer channel(s); if the bass improves, the speaker was out of phase.

Ground-Loop Noise? ⇒If you are using only one pair of RCA inputs, connect the RCA cable to the AMP 1 inputs.

No Fader? ⇒When using both sets of high-level inputs (ZX700.5 only), RCA dummy plugs must be inserted into the RCA AMP 2 inputs in order for the fader to work properly. If you do not have dummy plugs available, use unterminated RCA ends or cut the ends off of existing RCA cable. Do not use shorting plugs.

If you have more questions about the installation or operation of your new KICKER product, see the Authorized KICKER Dealer where you made your purchase. For more advice on installation, click on the SUPPORT tab on the Kicker homepage, www.kicker.com. Choose the TECHNICAL SUPPORT tab, choose the subject you are interested in, and then download or view the corresponding information. Please E-mail support@kicker.com or call Technical Services (405) 624-8583 for unanswered or specific questions.

Please Note: Modern high performance speakers have a lower DC Resistance than what used to be available. The Kicker Coaxial and Component speakers are rated at four ohms (some DC Resistances may be as low as 3 ohms) and work with any amplifier designed to operate at a four ohm load. If you want to use two Kicker Coaxial or Component speakers on a single channel of your amplifier wire the speakers in series. This will improve the sound quality, lower the total harmonic distortion and lessen the thermal load at the amplifier. This may prevent an amplifier from shutting down, due to over-current protection circuitry.

CAUTION: When jump starting the vehicle, be sure that connections made with jumper cables are correct. Improper connections can result in blown amplifier fuses as well as the failure of other critical systems in the vehicle.

Performance

Model	ZX550.3	ZX700.5
RMS Power in Watts, AMP 1 and AMP 2 all channels driven		
@14.4V, 4Ω Stereo, ≤1% THD+N	70 x 2	70 x 4
@14.4V, 2Ω Stereo, ≤1% THD+N	85 x 2	85 x 4
@14.4V, 4Ω Mono, ≤1% THD+N	N/A	165 x 2
RMS Power in Watts, Subwoofer channel driven		
@14.4V, 4Ω Mono, ≤1.5% THD+N	210 x 1	210 x 1
@14.4V, 2Ω Mono, ≤1.5% THD+N	420 x 1	420 x 1
Length:	16 3/4" (425mm)	20" (507mm)
Specifications common to all models:		
Height:	2 1/8" (54mm)	
Width:	9 5/8" (244mm)	
Frequency Response, ± 0.5 dB:	20 Hz - 20 kHz	
Signal-to-Noise Ratio:	>95 dB, a-weighted, re: rated power	
Input Sensitivity:	125 mV - 5 V low level, 250 mV - 10 V high level	
Electronic Crossover:	Variable (defeatable) HI pass, 50 - 200Hz, 12dB per octave, for the full-range channels Variable LOW pass, 50 - 200Hz, 24dB per octave, for the subwoofer channel	
Bass Boost:	Variable 0 to +18dB boost @ 40Hz, for the subwoofer channel	



Model ZX550.3
70 x 2, 210 x 1 @ 4 ohms from 20-20K, 20-200Hz, 14.4Vdc,
1% THD, CEA-2006 (Watts)
Signal to Noise Ratio -72 / -55 dBA CEA-2006 (ref: 1W, A-weighted)

Model ZX700.5
70 x 4, 210 x 1 @ 4 ohms from 20-20K, 20-200Hz, 14.4Vdc,
1% THD, CEA-2006 (Watts)
Signal to Noise Ratio -72 / -55 dBA CEA-2006 (ref: 1W, A-weighted)

Electronics **Limited Warranty**

Kicker warrants this product to be free from defects in material and workmanship under normal use for a period of THREE (3) MONTHS from date of original purchase with receipt. When purchased from an Authorized KICKER Dealer it is warranted for TWO (2) YEARS from date of original purchase with receipt. In all cases you must have the original receipt. Should service be necessary under this warranty for any reason due to manufacturing defect or malfunction during the warranty period, Kicker will repair or replace (at its discretion) the defective merchandise with equivalent merchandise at no charge. Warranty replacements may have cosmetic scratches and blemishes. Discontinued products may be replaced with more current equivalent products.

This warranty is valid only for the original purchaser and is not extended to owners of the product subsequent to the original purchaser. Any applicable implied warranties are limited in duration to a period of the express warranty as provided herein beginning with the date of the original purchase at retail, and no warranties, whether express or implied, shall apply to this product thereafter. Some states do not allow limitations on implied warranties; therefore these exclusions may not apply to you. This warranty gives you specific legal rights; however you may have other rights that vary from state to state.

WHAT TO DO IF YOU NEED WARRANTY OR SERVICE

Defective merchandise should be returned to your local Authorized Stillwater Designs (Kicker) Dealer for warranty service. Assistance in locating an Authorized Dealer can be found at www.kicker.com or by contacting Stillwater Designs directly. You can confirm that a dealer is authorized by asking to see a current authorized dealer window decal.

If it becomes necessary for you to return defective merchandise directly to Stillwater Designs (Kicker), call the Kicker Customer Service Department at (405) 624-8510 for a Return Merchandise Authorization (RMA) number. Package all defective items in the original container or in a package that will prevent shipping damage, and return to:

Stillwater Designs, 5021 North Perkins Road, Stillwater, OK 74075

The RMA number must be clearly marked on the outside of the package. Please return only defective components. The return of functioning items increases your return freight charges. Non-defective items will be returned freight-collect to you.

Include a copy of the original receipt with the purchase date clearly visible, and a "proof-of-purchase" statement listing the Customer's name, Dealer's name and invoice number, and product purchased. Warranty expiration on items without proof-of-purchase will be determined from the type of sale and manufacturing date code. Freight must be prepaid; items sent freight-collect, or COD, will be refused.

WHAT IS NOT COVERED?

This warranty is valid only if the product is used for the purpose for which it was designed.

It does not cover:

- o Damage due to improper installation
- o Subsequent damage to other components
- o Damage caused by exposure to moisture, excessive heat, chemical cleaners, and/or UV radiation
- o Damage through negligence, misuse, accident or abuse. Repeated returns for the same damage may be considered abuse
- o Any cost or expense related to the removal or reinstallation of product
- o Speakers damaged due to amplifier clipping or distortion
- o Items previously repaired or modified by any unauthorized repair facility
- o Return shipping on non-defective items
- o Products with tampered or missing barcode labels
- o Products returned without a Return Merchandise Authorization (RMA) number
- o Freight Damage
- o The cost of shipping product to Kicker
- o Service performed by anyone other than Kicker

HOW LONG WILL IT TAKE?

Kicker strives to maintain a goal of 72-hour service for all electronics (amplifiers, crossovers, equalizers, etc.) returns. Delays may be incurred if lack of replacement inventory or parts is encountered.

Failure to follow these steps may void your warranty. Any questions can be directed to the Kicker Customer Service Department at (405) 624-8510.

International Warranty

Contact your International Kicker dealer or distributor concerning specific procedures for your country's warranty policies.

WARNING: KICKER products are capable of producing sound levels that can permanently damage your hearing! Turning up a system to a level that has audible distortion is more damaging to your ears than listening to an undistorted system at the same volume level. The threshold of pain is always an indicator that the sound level is too loud and may permanently damage your hearing. Please use common sense when controlling volume.

GARANTÍA INTERNACIONAL *Versión Español*

Comuníquese con su concesionario o distribuidor Kicker internacional para obtener información sobre procedimientos específicos relacionados con las normas de garantía de su país.

ADVERTENCIA: Los excitadores Kicker son capaces de producir niveles de sonido que pueden dañar permanentemente el oído. Subir el volumen del sistema hasta un nivel que produzca distorsión es más dañino para el oído que escuchar un sistema sin distorsión al mismo volumen. El dolor es siempre una indicación de que el sonido es muy fuerte y que puede dañar permanentemente el oído. Sea precavido cuando controle el volumen.

La frase "combustible para vivir la vida Livin' Loud™ a todo volumen" se refiere al entusiasmo por la vida que la marca Kicker de estéreos de automóvil representa y a la recomendación a nuestros clientes de que vivan lo mejor posible ("a todo volumen") en todo sentido. La línea de altavoces y amplificadores Kicker es la mejor del mercado de audio de automóviles y por lo tanto representa el "combustible" para vivir a todo volumen en el área de "estéreos de automóvil" de la vida de nuestros clientes. Recomendamos a todos nuestros clientes que obedezcan todas las reglas y reglamentos locales sobre ruido en cuanto a los niveles legales y apropiados de audición fuera del vehículo.

INTERNATIONALE GARANTIE *Deutsche Version*

Nehmen Sie mit Ihren internationalen Kicker-Fachhändler oder Vertrieb Kontakt auf, um Details über die Garantieleistungen in Ihrem Land zu erfahren.

WARNUNG: KICKER-Treiber können einen Schallpegel erzeugen, der zu permanenten Gehörschäden führen kann! Wenn Sie ein System auf einen Pegel stellen, der hörbare Verzerrungen erzeugt, schadet das Ihren Ohren mehr, als ein nicht verzerrtes System auf dem gleichen Lautstärkepegel. Die Schmerzschwelle ist immer eine Anzeige dafür, dass der Schallpegel zu laut ist und zu permanenten Gehörschäden führen kann. Seien Sie bei der Lautstärkeeinstellung bitte vernünftig!

Der Slogan "Treibstoff für Livin' Loud" bezieht sich auf die mit den Kicker-Autostereosystemen assoziierte Lebensfreude und die Tatsache, dass wir unsere Kunden ermutigen, in allen Aspekten ihres Lebens nach dem Besten ("Livin' Loud") zu streben. Die Lautsprecher und Verstärker von Kicker sind auf dem Markt für Auto-Soundsysteme führend und stellen somit den "Treibstoff" für das Autostereoelebnis unserer Kunden dar. Wir empfehlen allen unseren Kunden, sich bezüglich der zugelassenen und passenden Lautstärkepegel außerhalb des Autos an die örtlichen Lärmvorschriften zu halten.

GARANTIE INTERNATIONALE *Versión Française*

Pour connaître les procédures propres à la politique de garantie de votre pays, contactez votre revendeur ou distributeur International Kicker.

AVERTISSEMENT: Les haut-parleurs Kicker ont la capacité de produire des niveaux sonores pouvant endommager l'ouïe de façon irréversible ! L'augmentation du volume d'un système jusqu'à un niveau présentant une distorsion audible endommage davantage l'ouïe que l'écoute d'un système sans distorsion au même volume. Le seuil de la douleur est toujours le signe que le niveau sonore est trop élevé et risque d'endommager l'ouïe de façon irréversible. Réglez le volume en faisant preuve de bon sens !

L'expression "carburant pour vivre plein pot" fait référence au dynamisme de la marque Kicker d'équipements audio pour véhicules et a pour but d'encourager nos clients à faire le maximum ("vivre plein pot") dans tous les aspects de leur vie. Les haut-parleurs et amplificateurs Kicker sont les meilleurs dans le domaine des équipements audio et représentent donc pour nos clients le "carburant pour vivre plein pot" dans l'aspect "installation audio de véhicule" de leur vie. Nous encourageons tous nos clients à respecter toutes les lois et réglementations locales relatives aux niveaux sonores acceptables à l'extérieur des véhicules.



STILLWATER
Designs®

P.O. Box 459 • Stillwater, Oklahoma 74076 • U.S.A. • (405) 624-8510

04272006+06ZX.4