



**Hardware Manual for the
HE500TIU050
HE500TIU100
IC300TIU101
HE500TIU102
HE500TIU103
HE500TIU110
IC300TIU111
HE500TIU112
HE500TIU113
HE500TIU200
IC300TIU201
HE500TIU202
HE500TIU203
And SmartStack Modules**

**Operator Station
Hardware Manual**

06 April 2000

GFK-1819

Warnings, Cautions, and Notes as Used in this Publication

Warning

Warning notices are used in this publication to emphasize that hazardous voltages, currents, temperatures or other conditions that could cause personal injury exist in this equipment or may be associated with its use.

In situations where inattention could cause either personal injury or damage to equipment, a Warning notice is used.

Caution

Caution notices are used where equipment might be damaged if care is not taken.

Note

Notes merely call attention to information that is especially significant to understanding and operating the equipment.

This document is based on information available at the time of its publication. While efforts have been made to be accurate, the information contained herein does not purport to cover all details or variations in hardware or software, nor to provide for every possible contingency in connection with installation, operation, or maintenance. Features may be described herein which are not present in all hardware and software systems. GE Fanuc Automation assumes no obligation of notice to holders of this document with respect to changes subsequently made.

GE Fanuc Automation makes no representations or warranty, expressed, implied, or statutory with respect to, and assumes no responsibility for the accuracy, completeness, sufficiency, or usefulness of the information contained herein. No warranties of merchantability or fitness for purpose shall apply.

The following are trademarks of GE Fanuc Automation North America, Inc.

Alarm Master	CIMSTAR	Helpmate	PROMACRO	Series Six
CIMPLICITY	GENet	Logicmaster	Series One	Series 90
CIMPLICITY 90 – ADS	Genius	ModelMaster	Series Three	VuMaster
CIMPLICITY Power TRAC	Genius PowerTRAC	ProLoop	Series Five	Workmaster

The following are trademarks of Horner Electric, APG, LLC.

Cscape	SmartStack	CsCAN
--------	------------	-------

ABOUT PROGRAMMING EXAMPLES

Any example programs and program segments in this manual or provided on accompanying diskettes are included solely for illustrative purposes. Due to the many variables and requirements associated with any particular installation, GE Fanuc cannot assume responsibility or liability for actual use based on the examples and diagrams. It is the sole responsibility of the system designer utilising the Operator Station to appropriately design the end system, to appropriately integrate the Operator Station and to make safety provisions for the end equipment as is usual and customary in industrial applications as defined in any codes or standards which apply.

NOTE: The programming examples shown in this manual are illustrative only. Proper machine operation is the sole responsibility of the system integrator.

DECLARATION OF EMC CONFORMITY

Manufacturer's Name: Horner Ireland Ltd.
Manufacturer's Address: Unit 1, Centrepont, Centre Park Road, Cork, Ireland

Declares that the products Models: HE500TIU050, HE500TIU100, IC300TIU101, HE500TIU102, HE500TIU110, IC300TIU111, HE500TIU200, IC300TIU201 and HE500TIU202.

Conforms to the following EMC standards:

EMC: EN 55 022, Radiated and Conducted Emissions
EN 50 082-1, RF, EFT/EFB, ESD Immunity

Supplementary Information:

The above conformity only relates to the products in a stand-alone capacity. The products are used as part of a system and are therefore classified as a component. As a component, the products are prohibited by EC regulations to carry a CE Mark for EMC conformity. Static discharge tests only apply to normal operation of the keyboards via the front panel. We would stress that the use of our products within your system, while helping to ensure compliance of your system to the same directives, do not necessarily guarantee that compliance will be achieved. We would also like to point out that the interpretation of the law concerning CE marking and its application to sub-assemblies and components is open to interpretation.

Date: 31 Mar 1999

TABLE OF CONTENTS

ABOUT PROGRAMMING EXAMPLES4
 DECLARATION OF EMC CONFORMITY.....4
 CHAPTER 1: INTRODUCTION7
 1.1 Scope 7
 1.2 Equipment Needed 9
 1.3 Technical Specifications.....11
 1.4 Upgrade Revision Software & Firmware12
 1.4.1 Scope12
 1.4.2 Software Upgrade12
 1.4.3 Firmware Upgrade12
 CHAPTER 2: TIU05015
 2.1 Scope15
 2.2 TIU050 Button Selection Actions15
 2.3 TIU050 Contrast Adjustment15
 2.4 TIU050 Ports.....16
 2.4.1 TIU050 Configuration of the RS-485 Port16
 2.5 TIU050 Dimensions.....17
 CHAPTER 3: TIU100/101/102/103.....19
 3.1 Scope19
 3.2 TIU10X Button Selection Actions.....19
 3.3 TIU10X Contrast Adjustment.....19
 3.4 TIU10X Rear View20
 3.5 TIU100 Ports.....20
 3.5.1 TIU10X Configuration of the RS-485 Port21
 3.6 TIU10X Dimensions22
 CHAPTER 4: TIU110/111/112/113.....23
 4.1 Scope23
 4.2 TIU11X Button Selection Actions23
 4.3 TIU11X Contrast Adjustment.....23
 4.4 TIU11X Rear View24
 4.5 TIU110 Ports.....24
 4.5.1 TIU11X Configuration of the RS-485 Port26
 4.6 TIU11X Dimensions26
 CHAPTER 5: TIU200/201/202/203.....27
 5.1 Scope27
 5.2 TIU20X Button Selection Actions.....27
 5.3 TIU20X Contrast Adjustment.....28
 5.4 TIU20X Rear View28
 5.5 TIU20X Ports28
 5.5.1 TIU20X Configuration of the RS-485 Port30
 5.6 TIU20X Dimensions30
 CHAPTER 6: COMMUNICATIONS31
 6.1 PC to Operator Station Communications31
 6.2 Automation Equipment (AE) Communications Connections.....31
 6.2.1 Recommended Automation Equipment Communication Cables.....31
 6.3 RS-232 Connection.....31
 6.4 RS-422/485 Four-Wire32
 6.5 RS-485 Two-Wire33
 6.6 Current Loop.....34
 CHAPTER 7: GETTING STARTED35
 7.1 Self-Test35
 7.1.1 Contrast Band35

7.1.2	Display Test	35
7.1.3	Keyboard Test.....	35
7.1.4	RAM Test.....	35
7.1.5	Serial Loop-back Tests.....	35
7.2	Updating the Protocol.....	36
7.3	Updating the Operating System.....	36
CHAPTER 8 : NETWORKS.....		37
8.1	Scope	37
8.2	Controller Area Network (CAN) Overview	37
8.2.1	CAN Features	37
8.3	CsCAN Network Overview	37
8.3.1	CsCAN Network Features	37
8.3.2	CsCAN Network Operation.....	37
8.4	DeviceNet Overview.....	38
8.4.1	DeviceNet Features.....	38
8.4.2	DeviceNet Protocol	39
8.4.3	DeviceNet Operation	39
8.5	CAN Wiring Rules	40
8.6	Profibus	41
8.6.1	Profibus Wiring.....	41
CHAPTER 9: SMARTSTACK™		43
9.1	Scope	43
9.2	Installing and Removing a SmartStack Module.....	43
9.2.1	Installing SmartStack Modules.....	43
9.2.2	Removing SmartStack Modules.....	43

CHAPTER 1: INTRODUCTION

1.1 Scope

The Operator Station (TIU050/10X/11X/20X) is an Operator Station (OS) that provides extensive monitoring and control in an extremely small package. The Operator Station "OS" product line offers four distinct categories of products as described in Table 1.1.

Table 1.1 – Operator Station (OS) Product Line	
Note: Only IC300 TIU101 / IC300 TIU111 IC300 TIU201 models are available through GE Fanuc Channels.	
Model	Description
TIU050: Text Only	
HE500TIU050-001	2 lines x 20 characters.
HE500TIU050-002	2 lines x 20 characters with Real Time Clock.
TIU10x: Text / Semi-Graphics	
HE500TIU100-01	8 Lines x 20 Characters plus 128 x 64 pixels.
HE500TIU100-02	8 Lines x 20 Characters plus 128 x 64 pixels with Real Time Clock.
HE500TIU100-03	8 Lines x 20 Characters plus 128 x 64 pixels with Current Loop.
HE500TIU100-04	8 Lines x 20 Characters plus 128 x 64 pixels with Current Loop and Real Time Clock.
HE500TIU100-05	8 Lines x 20 Characters plus 128 x 64 pixels with Stud Type Metalwork
HE500TIU100-06	8 Lines x 20 Characters plus 128 x 64 pixels with wide temperature display.
HE500TIU100-07	8 Lines x 20 Characters plus 128 x 64 pixels with Bezel
HE500TIU100-09	8 Lines x 20 Characters plus 128 x 64 pixels with no metal and dill connectors
IC300TIU101-01	8 Lines x 20 Characters plus 128 x 64 pixels with CsCAN Network .
IC300TIU101-02	8 Lines x 20 Characters plus 128 x 64 pixels with CsCAN Network and Real Time Clock.
HE500TIU102-01	8 Lines x 20 Characters plus 128 x 64 pixels with a Profibus™ Network .
HE500TIU102-02	8 Lines x 20 Characters plus 128 x 64 pixels with Profibus™ Network and Real Time Clock.
HE500TIU103-01	8 Lines x 20 Characters plus 128 x 64 pixels with DeviceNet™ Networks .
HE500TIU103-02	8 Lines x 20 Characters plus 128 x 64 pixels with DeviceNet™ Networks and Real Time Clock.
TIU11X: Text / Semi Graphics with Numeric Keypad	
HE500TIU110-01	8 Lines x 20 Characters plus 128 x 64 pixels plus a Numeric keypad.
HE500TIU110-02	8 Lines x 20 Characters plus 128 x 64 pixels plus a Numeric keypad with Real Time Clock.
HE500TIU110-03	8 Lines x 20 Characters plus 128 x 64 pixels plus a Numeric keypad with Current Loop.
HE500TIU110-04	8 Lines x 20 Characters plus 128 x 64 pixels plus a Numeric keypad with Current Loop and Real Time Clock.
HE500TIU110-05	8 Lines x 20 Characters plus 128 x 64 pixels with Stud Type Metalwork.
HE500TIU110-06	8 Lines x 20 Characters plus 128 x 64 pixels with wide temperature display.
HE500TIU110-07	8 Lines x 20 Characters plus 128 x 64 pixels with Bezel
HE500TIU110-09	8 Lines x 20 Characters plus 128 x 64 pixels with no metal and dill connectors
IC300TIU111-01	8 Lines x 20 Characters plus 128 x 64 pixels plus a Numeric keypad with CsCAN Network .
IC300TIU111-02	8 Lines x 20 Characters plus 128 x 64 pixels plus a Numeric keypad with CsCAN Network and Real Time Clock.
HE500TIU112-01	8 Lines x 20 Characters plus 128 x 64 pixels plus a Numeric keypad with Profibus™ Network .
HE500TIU112-02	8 Lines x 20 Characters plus 128 x 64 pixels plus a Numeric keypad with Profibus™ Network and Real Time Clock.

HE500TIU113-01	8 Lines x 20 Characters plus 128 x 64 pixels with DeviceNet™ Network .
HE500TIU113-02	8 Lines x 20 Characters plus 128 x 64 pixels with DeviceNet™ Network and Real Time Clock.
TIU20X: Text / Full Graphics with Numeric / Function Keypad	
HE500TIU200	16 Lines x 40 Characters plus 240 x 128 pixels plus a Numeric keypad / Function keypad. Optional SmartStack I/O.
IC300TIU201	16 Lines x 40 Characters plus 240 x 128 pixels plus a Numeric keypad / Function keypad. Optional SmartStack I/O. Can be used with CsCAN Network .
HE500TIU202	16 Lines x 40 Characters plus 240 x 128 pixels plus a Numeric keypad / Function keypad. Optional SmartStack I/O. Can be used in a Profibus™ Network .
HE500TIU203	16 Lines x 40 Characters plus 240 x 128 pixels plus a Numeric keypad / Function keypad. Optional SmartStack I/O. Can be used with DeviceNet™ Network .

The front panel of the OS has a bright and clear display (LCD with adjustable back lit) and easy-to-use push buttons. On the back panel are communication ports for connection to automation equipment (programmable logic controller, drive, weighing equipment or other equipment) and a PC (IBM or compatible computer). Also located on the back panel or end of the back panel depending on the model, the OS has clearly displayed features such as power input, PC and PLC port, Tx and Rx LEDs. Also, depending on the model, a network port is provided for connection to whichever OS network you have chosen.

The OS supports a variety of protocols. Various protocols can be downloaded through the PC port and stored in the unit's flash memory. The operating system can also be downloaded through the PC port.

The OS range supports 3 network options. CsCAN (TIUXX1) and Device (TIUXX3) and Profibus with the TIUXX2 range.

	HE500TIU050	HE500TIU10X	HE500TIU11X	HE500TIU20X
Software Cbreeze	Included	Included	Included	Included
Programming Port RS232	Standard	Standard	Standard	Standard
Communication Port 232/485	1	1	1	1
Flash Ram	64 K Words	256 K Words	256 K Words	512 K Words
Memory Upgrade	No	No	No	1 Meg
Words SRam	32 K Bytes	128 K Bytes	128 K Bytes	128 K Bytes
Memory Upgrade	No	No	No	512 K Bytes
Total Pages	300	300	300	300
Characters per Page	2x20	8x20	8x20	16x40
Graphics pixels	Text Only	128 x 64	128 x 64	240 x 128
Data fields/page	8	8	8	24
No. of Text tables	249	249	249	249
Text table size Rows & Columns	No	No	No	256
Recipe Memory	0	64K	64K	64K
Recipes	No	Standard	Standard	Standard
Editable Fonts	No	Standard	Standard	Standard
Scaling Range checking	Standard	Standard	Standard	Standard
Tending	No	Standard	Standard	Standard
Graphing	No	Standard	Standard	Standard
Editable Graphics	No	No	No	Standard

Animated Bitmaps	No	No	No	Standard
Alarms and Status pages	Standard	Standard	Standard	Standard
Numeric keys	Standard	No	Standard	Standard
System keys	4	4	4	4
Function keys *	10	No	12	18
LED's	No	No	No	10
SmartStack option	No	No	No	Standard
Battery Back Ram + Real Time Clock	Optional	Optional	Optional	Standard
Comprehensive Math's Facilities	No	1024 lines	1024 lines	1024 lines
Day & Time Scheduling, Background Task	No	Standard	Standard	Standard
Internal Registers	No	1024 %R	1024 %R	1024 %R
Operating Temperature C°	0 to 50	0 to 50	0 to 50	0 to 50
Storage Temperature C°	-10 to 70	-10 to 70	-10 to 70	-10 to 70
Humidity Non Condensing Storage	10-90%	10-90%	10-90%	10-90%
Environmental NEMA4 / IP65	Yes	Yes	Yes	Yes
Y2K Certified CE Approved	Yes	Yes	Yes	Yes
Size -Width ,Height ,Depth mm	180 X 120 X 60	121 X 105 X 38	172 X 105 X 38	281 X 192 X 58
Cut-out -- Width , Height mm	151 X 89	100 X 85	153 X 85	242 X 158
Screen dimensions mm	80 X 17	70 X 38	70 X 38	130 X 75
Input Voltage Range	9-35 Vdc	9-35 Vdc	9-35 Vdc	9-35 Vdc
Weight (grams)	325	370	450	1855
Network- DeviceNet, CsCAN	No	Optional	Optional	Optional
Data xfer from Automated device via network - Profibus	No	Optional	Optional	Optional

* System keys can be programmed to be function keys at specific times in the project. See Function keys in CBREEZE Software Manual MAN0023

** The TIU100/110 is available with two non-standard features: 20mA current loop communication and a real-time clock (RTC). Both can be ordered at the time of purchase. The current loop can be re-fit by the user later. The RTC requires factor re-fit. The TIU050 is only available with the real-time clock option.

*** The TIU20X provides for the display of both text and full graphics and has a Numeric/Function Keypad. It also allows the use of a wide range of SmartStack I/O options.

1.2 Equipment Needed

1. The current version of **CBREEZE™** software install on a PC running Windows 95™, Windows 98™ or Windows NT®.
2. TIU050/10X/11X/20X Interface Unit.

3. PC to TIU Programming Cable HE693CBL232 or equivalent See Chapter on Communications

1.3 Technical Specifications

Table 1.2 – Technical Specifications					
Parameter	Conditions	Min.	Typical	Max.	Units
Input voltage (V _i)		10	24	32	VDC
Typical power consumption TIU050 TIU10X TIU11X TIU20X	V _i = 24VDC V _i = 24VDC V _i = 24VDC V _i = 24VDC		130 130 130 350		mA
Inrush input current	V _i = 24VDC for 4ms		260		mA
Operating temperature TIU050 TIU10X TIU10X-6 TIU11X TIU11X-6 TIU20XA TIU20XB or higher		0 0 -10 0 -10 0 0		50 50 60 50 60 45 50	°C
Storage temperature		-20		70	°C
Relative Humidity	(non-condensing)	10		90	%
Weight TIU050 TIU10X TIU11X TIU20X			320 370 470 1870	350 400 500 1900	g
Dimensions TIU050 TIU10X TIU11X TIU20X			179 x 111 x 60 121 x 105 x 38 172 x 105 x 38 282 x 194 x 62		mm
Cable Lengths † RS-232 RS-485		1		15 1500	m
IP rating	NEMA 4-12/IP65				
EMC Conformance	EN 55 022, Radiated and Conducted Emissions EN 61000-4-3, Radiated and Conducted RF Immunity ENV 50144				
† Cables beyond the maximum recommended length may create communication problems. Both ends of an RS-485 network must be properly terminated at 120Ω and grounded.					

1.4 Upgrade Revision Software & Firmware

1.4.1 *Scope*

To avail of any new features that are included in this new release on units that were purchased previous to this release, both software and firmware require updating by the user. Any new unit will be set-up for the latest version released.

1.4.2 *Software Upgrade*

To update the software requires that the user install the new version of software from the installation CD. You may install the new software over any previous version installed. See section 1.4 Software Installation Instructions.

To update existing projects simple open the project from the newly installed version of the software. Once the project is saved to disk the update is complete. For backup reasons we recommend that you save the new version of your project in a different location or under a different file name.

1.4.3 *Firmware Upgrade*

The following steps assume that a project or configuration is loaded to the Operator Station and that the user is running the latest version of software.

- a) Upload the project/configuration from the unit.
- b) If a customised character set is loaded to the unit then upload the character set also.
- c) Choose Automation Device from main menu Configure/Communication Settings.
- d) From File menu choose Update TIU Operating System. (See Updating Operating System for more details).
- e) From File menu choose Update TIU Protocol. If you are updating from firmware version 2.00 or later then you just have to update to the latest protocol file. However if you are updating from firmware version 1.24 or earlier you must update to a Upgrade.1xx protocol file first, then update to the latest firmware revision. See Note. (See updating protocol for further information).
- f) Choose Download Character Sets to TIU from File menu.
- g) Choose Download Project to TIU from File menu.

Note: When updating the protocol file the screen may go blank after the protocol file is complete. Continue with the procedure as described and the display will recover.

NOTES

CHAPTER 2: TIU050

2.1 Scope

The TIU050 is a 2 line text only display terminal. The hardware description is detailed in this chapter.

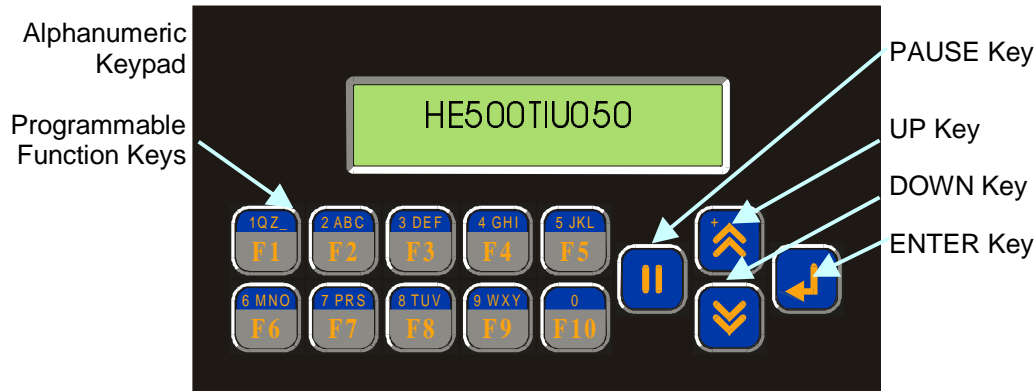

Figure 2.1 – Front View of TIU050

2.2 TIU050 Button Selection Actions

- PAUSE** key selects data for editing OR exits from data editing.
- PAUSE & DOWN** keys pressed together, enters sub menu pages.
- PAUSE & UP** keys pressed together, exits sub menus to the parent menu pages.
- UP** key selects the previous menu page, sub menu page, alarms, and increments data
- DOWN** key selects the next menu page, sub menu page, alarms and also decrements data.
- ENTER** key sends data to the automation equipment, accepts alarms, and displays accepted alarms.
- ALPHANUMERIC KEYPAD** and **FUNCTION KEYS** can be used to enter data or can be used to preform some pre-programmed action.

2.3 TIU050 Contrast Adjustment

On menu page 1 (after the start-up screen), hold the **ENTER** key and press the **UP** or **DOWN** key to adjust the contrast. The contrast setting is stored and not lost after removing power.

CONTRAST BAND - allows the user to set the lower and upper limits of contrast. Adjust the lower limit using the UP or DOWN key and press Enter when done. Do the same for the upper limit.

WARNING: - Changes to the lower or upper limits may allow the user to set the contrast to a setting where the display may appear blank. It is recommended that the factory setting are used (Min 8A, Max FE).

2.4 TIU050 Ports

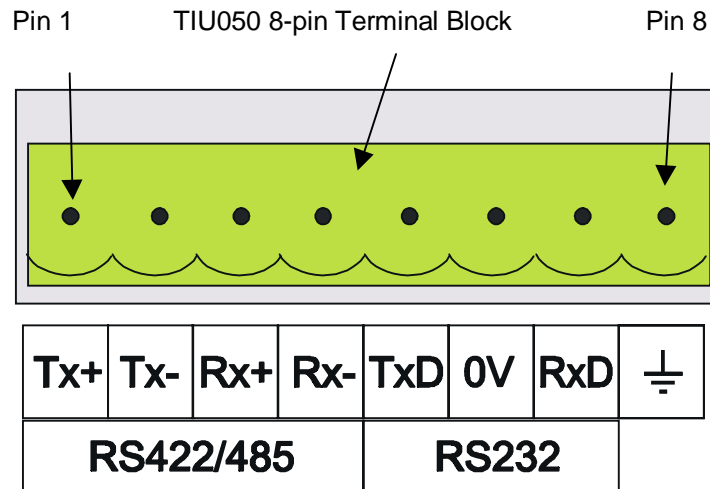

Figure 2.2 – Automation Equipment Serial Port

2.4.1 TIU050 Configuration of the RS-485 Port

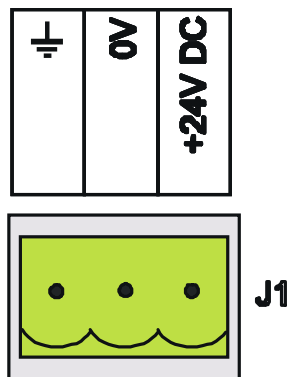

Figure 2.3 – Power Connector
Powered by +24VDC and Ground.

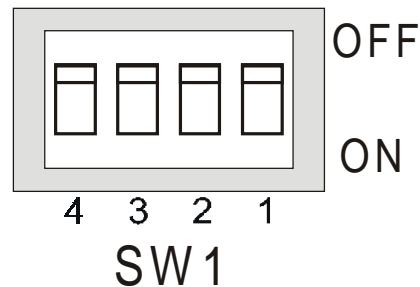

Figure 2.4 – Configuration Bank

The configuration bank (shown in Figure 2.5) sets the parameters of the RS-485 port as described in Table 2.1.

Switch 1	ON: Pull-up (must be used together with switch 3) OFF: no Pull-up
Switch 2	ON: 120Ω termination OFF: no termination
Switch 3	ON: Pull-down (must be used together with switch 1) OFF: no Pull-down
Switch 4	Reserved for future use
NOTE: Switch 1 and 3 must be used together. Either both pull-up and pull-down are used or neither is used.	

Pull-up and **Pull-down** switches are used to increase the signal level on the RS-485 bus. This is useful if there is a long bus and a significant amount of attenuation is anticipated.

Termination resistance of 120Ω must be placed across each end of the RS-485 bus. With switch 2 ON, a 120Ω resistance is placed across the bus. This is only used if the TIU050/100/110 is the last device at either end of the bus.

2.5 TIU050 Dimensions

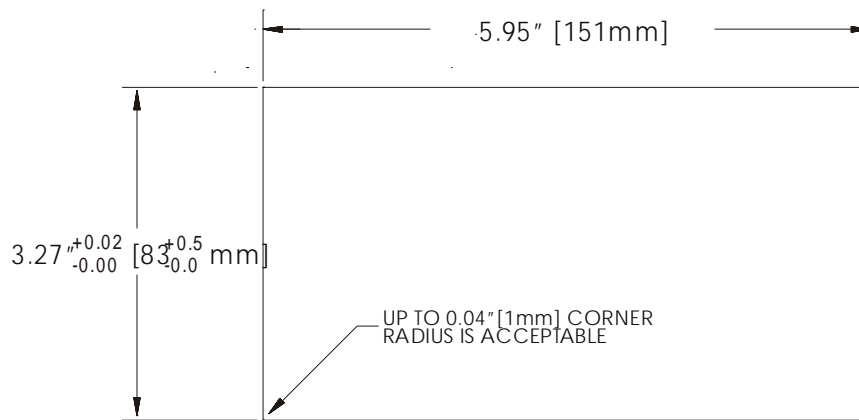

TIU050 CUTOUT DETAILS

TOLERANCES ARE $\pm 0.01''$ [0.3mm] UNLESS STATED OTHERWISE

Figure 2.5 – TIU050 Cutout

NOTES

CHAPTER 3: TIU100/101/102/103

3.1 Scope

The TIU10X 128 x 64 pixel display, which allows for some graphics and various fonts to be displayed. . The hardware description is detailed in this chapter.

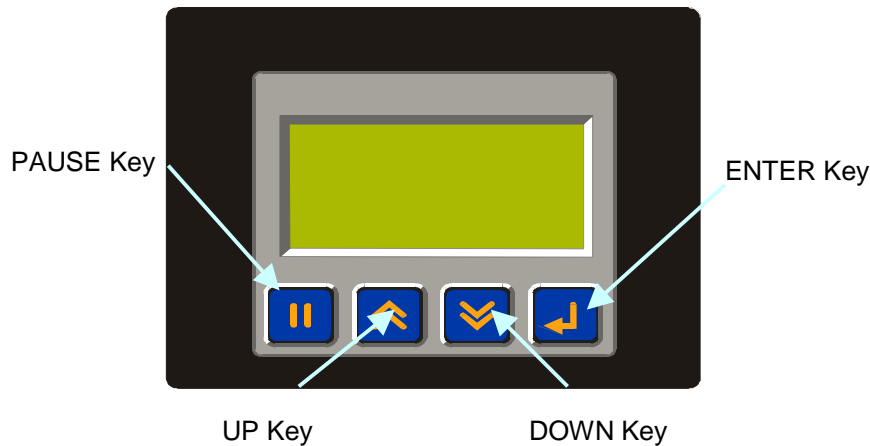

Figure 3.1 - Front View of TIU100

3.2 TIU10X Button Selection Actions

- PAUSE** key selects data for editing OR exits from data editing.
- PAUSE & DOWN** keys pressed together, enters sub menu pages.
- PAUSE & UP** keys pressed together, exits sub menus to the parent menu pages.
- UP** key selects the previous menu page, sub menu page, alarms, and increments data
- DOWN** key selects the next menu page, sub menu page, alarms and also decrements data.
- ENTER** key sends data to the automation equipment, accepts alarms, and displays accepted alarms.

3.3 TIU10X Contrast Adjustment

On menu page 1 (after the start-up screen), hold the **ENTER** key and press the **UP** or **DOWN** key to adjust the contrast. The contrast setting is stored and not lost after removing power.

CONTRAST BAND - allows the user to set the lower and upper limits of contrast. Adjust the lower limit using the UP or DOWN key and press Enter when done. Do the same for the upper limit.

WARNING: - Changes to the lower or upper limits may allow the user to set the contrast to a setting where the display may appear blank. It is recommended that the factory setting are used (Min 8A, Max FE).

3.4 TIUX Rear View

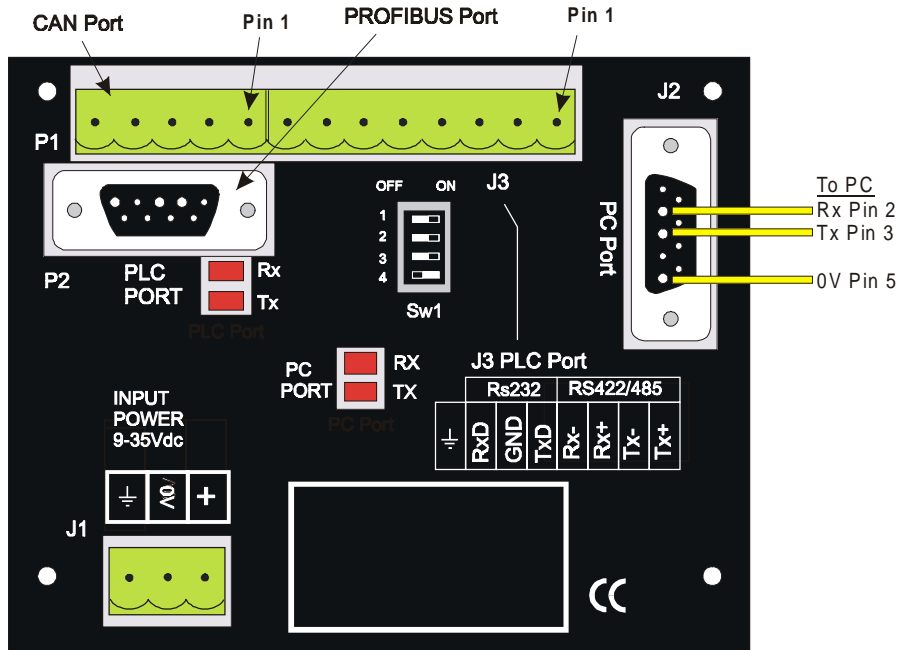

Figure 3.2 – Rear View of TIU100/101/102

3.5 TIU100 Ports

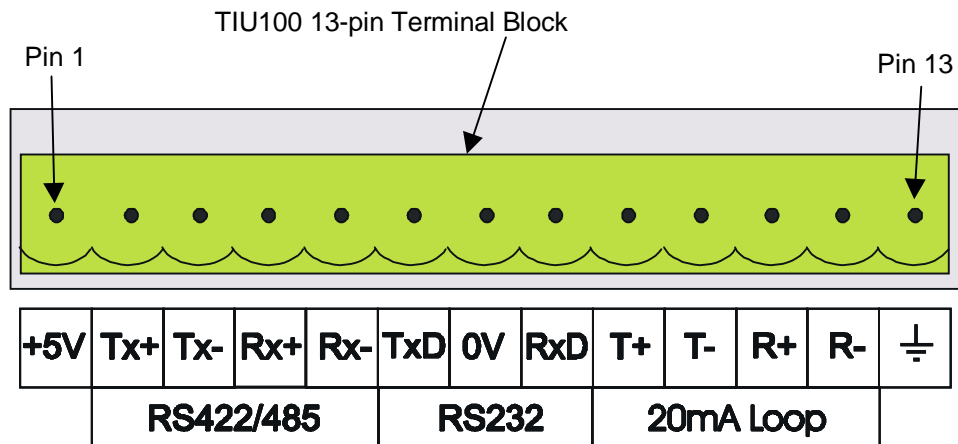



Figure 3.4 – Automation Equipment Port Receive & Transmit LEDs
The LED's flash when the TIU10X is communicating with the AE.

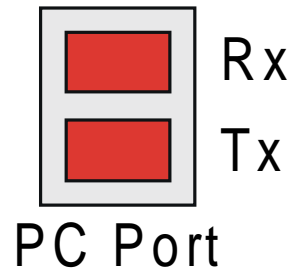

Figure 3.5 – PC Port Receive & Transmit LEDs
The LED's flash when the PC is communicating with the TIU10X

Figure 3.3 – Automation Equipment Serial Port

3.5.1 *TIU10X Configuration of the RS-485 Port*

The configuration bank (shown in Figure 3.8) sets the parameters of the RS-485 port as described in Table 3.1.

Table 3.1 – Configuration Bank	
Switch 1	ON: Pull-up (must be used together with switch 3) OFF: no Pull-up
Switch 2	ON: 120Ω termination OFF: no termination
Switch 3	ON: Pull-down (must be used together with switch 1) OFF: no Pull-down
Switch 4	Reserved for future use
NOTE: Switch 1 and 3 must be used together. Either both pull-up and pull-down are used or neither is used.	

Pull-up and **Pull-down** switches are used to increase the signal level on the RS-485 bus. This is useful if there is a long bus and a significant amount of attenuation is anticipated.

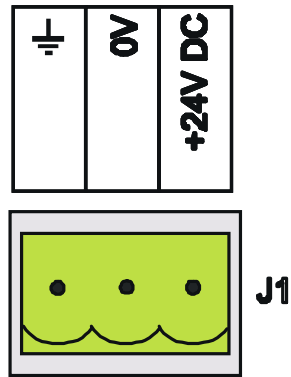

Figure 3.6 – Power Connector
Powered by +24VDC and Ground.

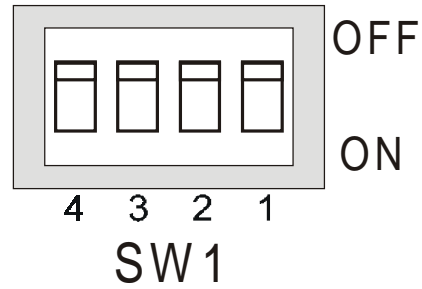
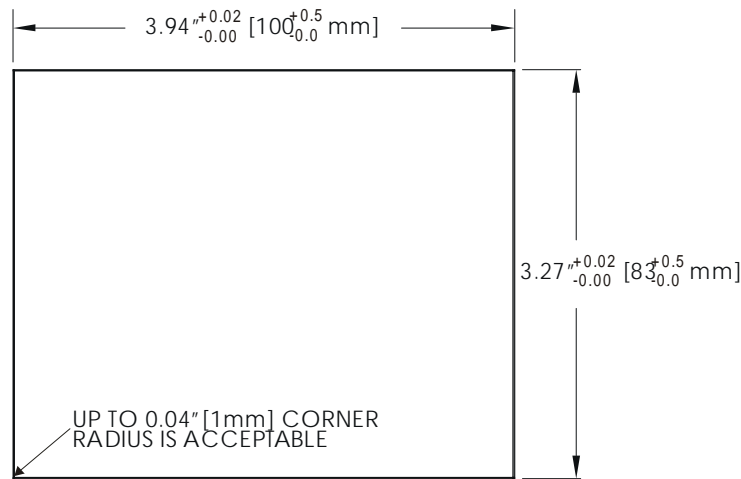

Figure 3.7 – Configuration Bank

Termination resistance of 120Ω must be placed across each end of the RS-485 bus. With switch 2 ON, a 120Ω resistance is placed across the bus. This should only be used if the TIU050/100/110 is the last device at either end of the bus.

3.6 TIU10X Dimensions



TIU10X CUTOUT DETAILS

TOLERANCES ARE +/- 0.01" [0.3mm] UNLESS STATED OTHERWISE

Figure 3.8 – TIU10X Cutout

CHAPTER 4: TIU110/111/112/113

4.1 Scope

The TIU11X 128 x 64 pixel display, which allows for some graphics and various fonts to be displayed. The hardware description is detailed in this chapter.



Figure 4.1 – Front View of TIU110

4.2 TIU11X Button Selection Actions

- PAUSE** key selects data for editing OR exits from data editing.
- PAUSE & DOWN** keys pressed together, enters sub menu pages.
- PAUSE & UP** keys pressed together, exits sub menus to the parent menu pages.
- UP** key selects the previous menu page, sub menu page, alarms, and increments data
- DOWN** key selects the next menu page, sub menu page, alarms and also decrements data.
- ENTER** key sends data to the automation equipment, accepts alarms, and displays accepted alarms.
- ALPHANUMERIC KEYPAD** and **PROGRAMMABLE KEYS** can be used to enter data or can be used to preform some pre-programmed action.

4.3 TIU11X Contrast Adjustment

On menu page 1 (after the start-up screen), hold the **ENTER** key and press the **UP** or **DOWN** key to adjust the contrast. The contrast setting is stored and not lost after removing power.

CONTRAST BAND - allows the user to set the lower and upper limits of contrast. Adjust the lower limit using the UP or DOWN key and press Enter when done. Do the same for the upper limit.

WARNING: - Changes to the lower or upper limits may allow the user to set the contrast to a setting where the display may appear blank. It is recommended that the factory setting are used (Min 8A, Max FE).

4.4 TIU11X Rear View

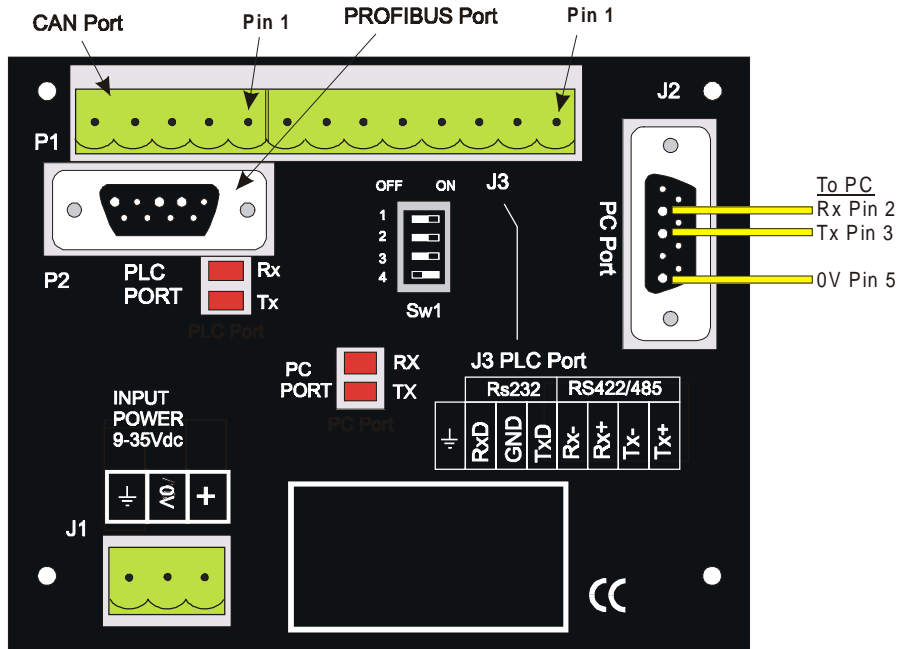

Figure 4.2 – Rear View of TIU11X

4.5 TIU110 Ports

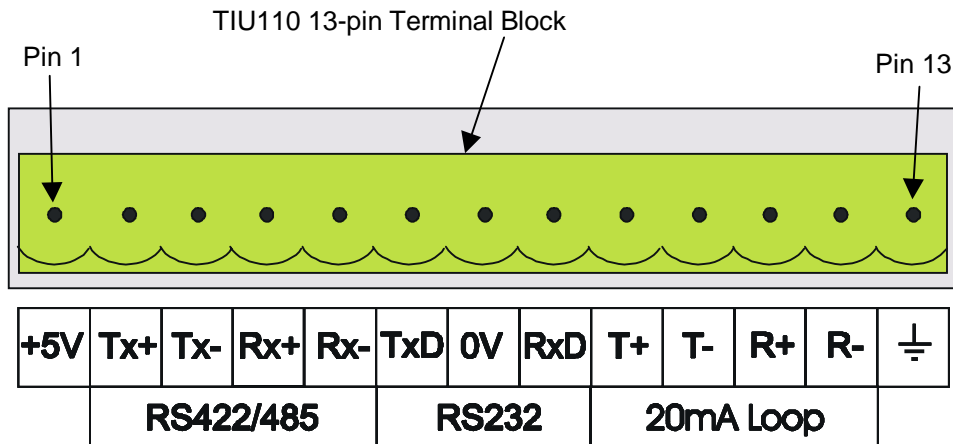

Figure 4.3 – Automation Equipment Serial Port



Figure 4.4 – Automation Equipment Port Receive & Transmit LEDs

The LED's flash when the TIU110 is communicating with the AE.

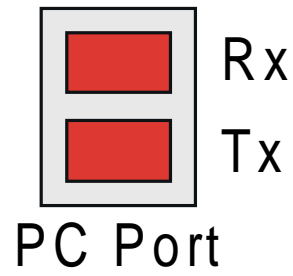

Figure 4.5 – PC Port Receive & Transmit LEDs

The LED's flash when the PC is communicating with the TIU110

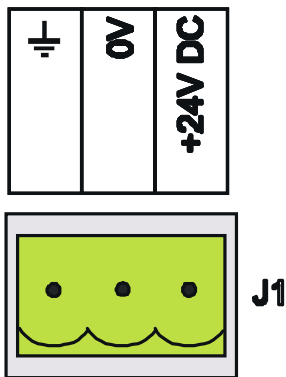

Figure 4.6 – Power Connector
Powered by +24VDC and Ground.

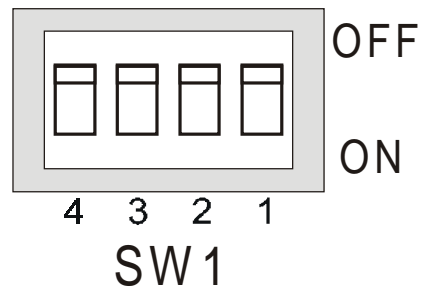

Figure 4.7 – Configuration Bank

4.5.1 TIU11X Configuration of the RS-485 Port

The configuration bank (shown in Figure 4.8) sets the parameters of the RS-485 port as described in Table 4.1.

Table 4.1 – Configuration Bank	
Switch 1	ON: Pull-up (must be used together with switch 3) OFF: no Pull-up
Switch 2	ON: 120Ω termination OFF: no termination
Switch 3	ON: Pull-down (must be used together with switch 1) OFF: no Pull-down
Switch 4	Reserved for future use
NOTE: Switch 1 and 3 must be used together. Either both pull-up and pull-down are used or neither is used.	

Pull-up and **Pull-down** switches are used to increase the signal level on the RS-485 bus. This is useful if there is a long bus and a significant amount of attenuation is anticipated.

Termination resistance of 120Ω must be placed across each end of the RS-485 bus. With switch 2 ON, a 120Ω resistance is placed across the bus. This should only be used if the TIU050/100/110 is the last device at either end of the bus.

4.6 TIU11X Dimensions

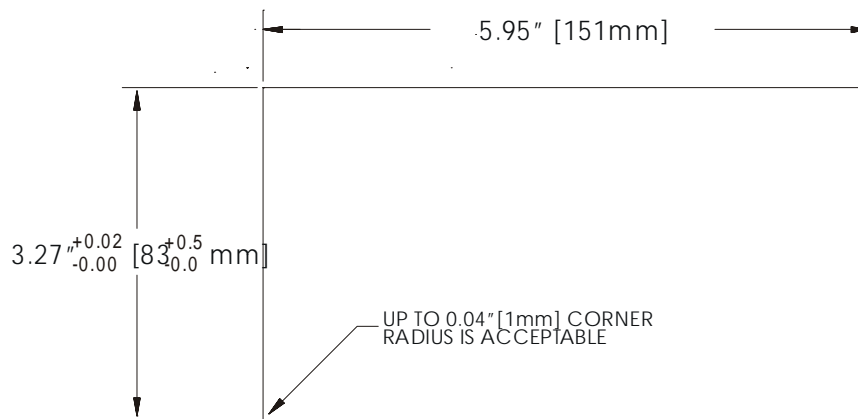

TIU11X CUTOUT DETAILS

TOLERANCES ARE +/- 0.01" [0.3mm] UNLESS STATED OTHERWISE

Figure 4.8 – TIU11X Cutout

CHAPTER 5: TIU200/201/202/203

5.1 Scope

The TIU20X is 240 x 128 pixel display which allows for full graphic screen. The hardware description is cover under the following chapter

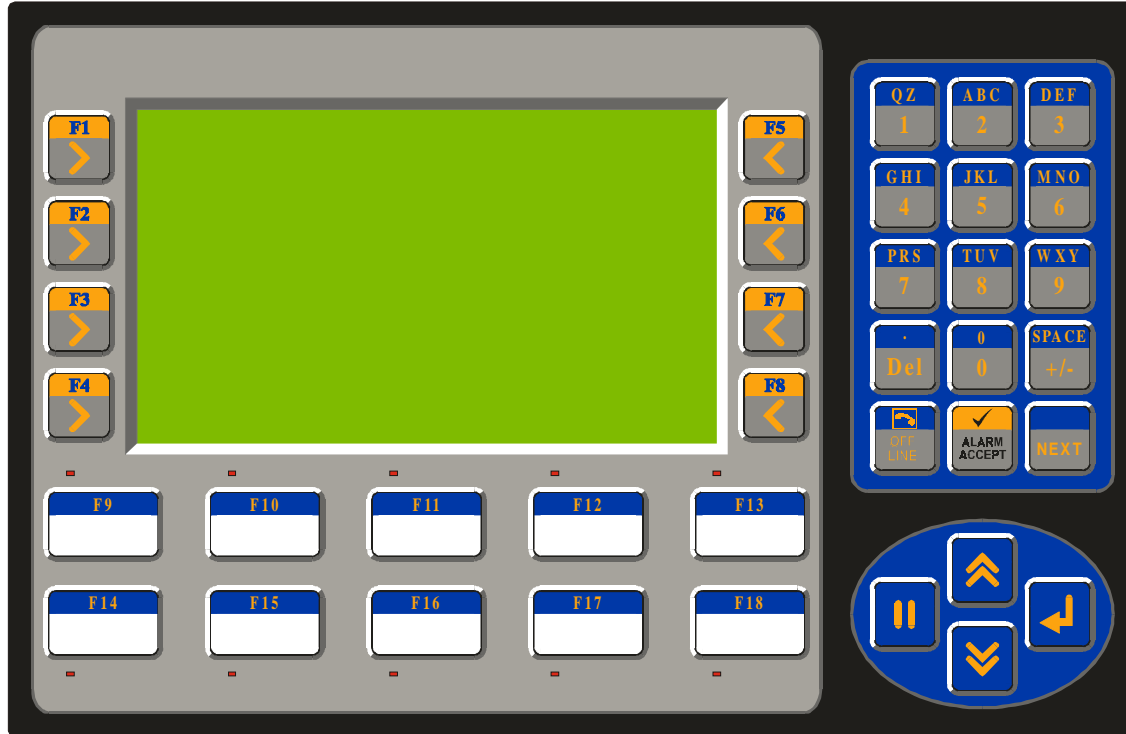

Figure 5.1 – Front View of TIU20X

5.2 TIU20X Button Selection Actions

- PAUSE** key selects data for editing OR exits from data editing.
- PAUSE & DOWN** keys pressed together, enters sub menu pages.
- PAUSE & UP** keys pressed together, exits sub menus to the parent menu pages.
- UP** key selects the previous menu page, sub menu page, alarms, and increments data
- DOWN** key selects the next menu page, sub menu page, alarms and also decrements data.
- ENTER** key sends data to the automation equipment, accepts alarms, and displays accepted alarms.
- ALPHANUMERIC KEYPAD** can be used to enter data
- PROGRAMMABLE KEYS** can be used to preform some pre-programmed action.

5.3 TIU20X Contrast Adjustment

On menu page 1 (after the start-up screen), hold the **ENTER** key and press the **UP** or **DOWN** key to adjust the contrast. The contrast setting is stored and not lost after removing power.

CONTRAST BAND - allows the user to set the lower and upper limits of contrast. Adjust the lower limit using the UP or DOWN key and press Enter when done. Do the same for the upper limit.

WARNING: - Changes to the lower or upper limits may allow the user to set the contrast to a setting where the display may appear blank. It is recommended that the factory setting are used (Min 8A, Max FE).

5.4 TIU20X Rear View

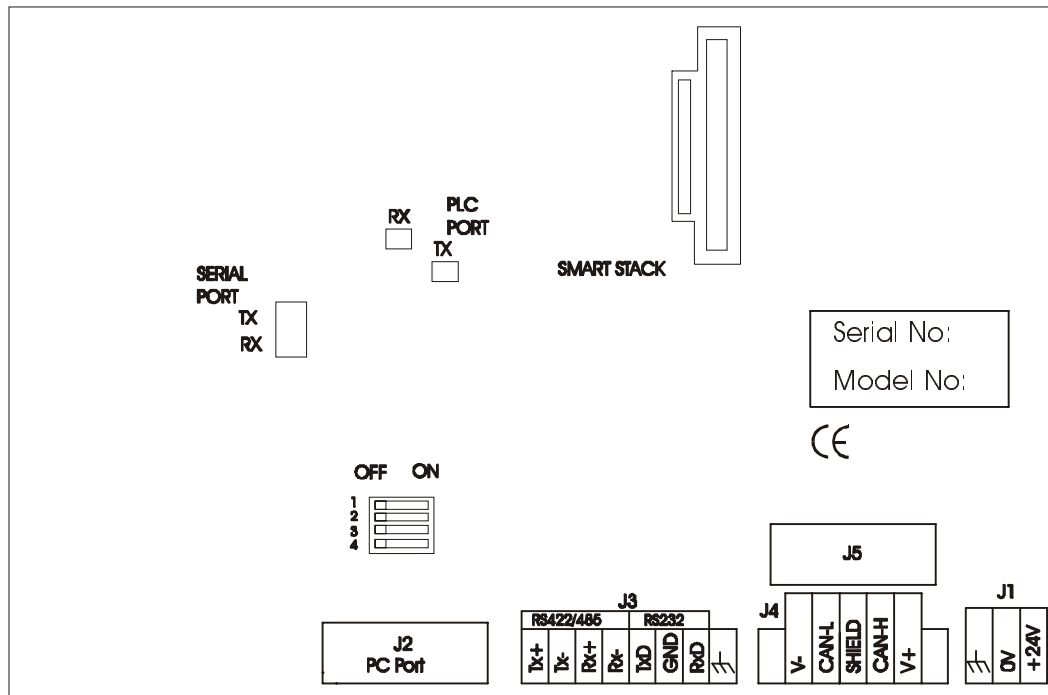

Figure 5.2 – Rear View of TIU20X

5.5 TIU20X Ports

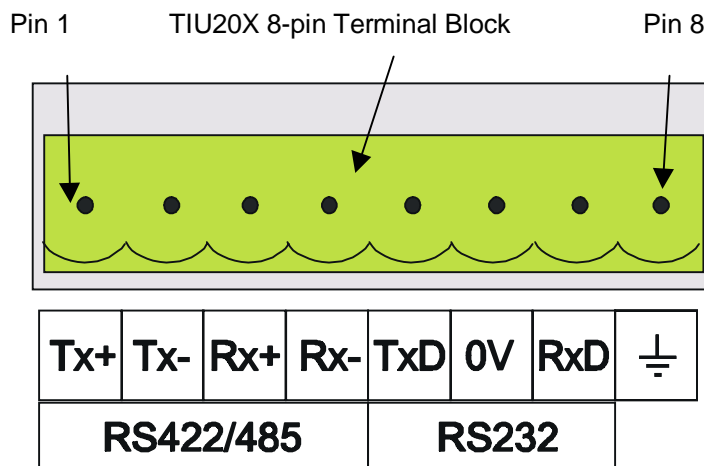

Figure 5.3 Automated Equipment Serial Port

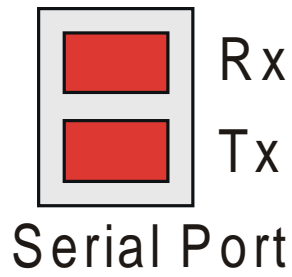

Figure 5.4 – Automation Equipment Port Receive & Transmit LEDs

The LED's flash when the TIU20X is communicating with the AE.

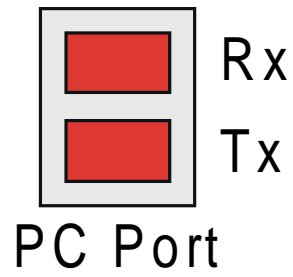

Figure 5.5 – PC Port Receive & Transmit LEDs

The LED's flash when the PC is communicating with the TIU20X

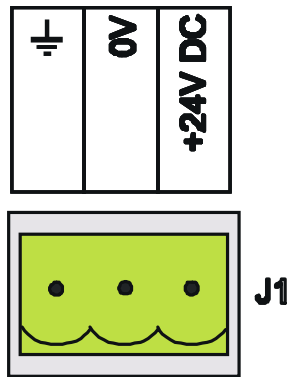

Figure 5.6 – Power Connector
Powered by +24VDC and Ground.

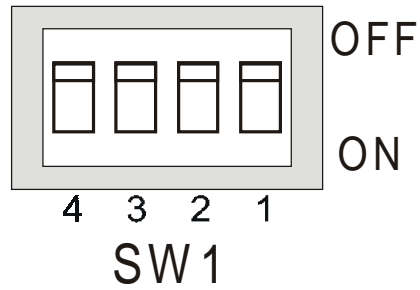

Figure 5.7 – Configuration Bank

5.5.1 TIU20X Configuration of the RS-485 Port

The configuration bank (shown in Figure 2.23) sets the parameters of the RS-485 port as described in Table 5.1.

Table 5.1 – Configuration Bank	
Switch 1	ON: Pull-up (must be used together with switch 3) OFF: no Pull-up
Switch 2	ON: 120Ω termination OFF: no termination
Switch 3	ON: Pull-down (must be used together with switch 1) OFF: no Pull-down
Switch 4	Reserved for future use
NOTE: Switch 1 and 3 must be used together. Either both pull-up and pull-down are used or neither is used.	

Pull-up and **Pull-down** switches are used to increase the signal level on the RS-485 bus. This is useful if there is a long bus and a significant amount of attenuation is anticipated.

Termination resistance of 120Ω must be placed across each end of the RS-485 bus. With switch 2 ON, a 120Ω resistance is placed across the bus. This should only be used if the TIU050/10X/11X/20X is the last device at either end of the bus.

5.6 TIU20X Dimensions

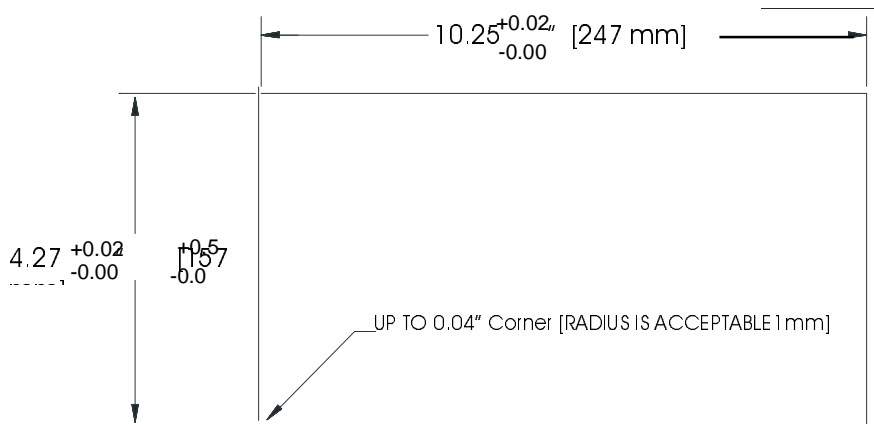

TIU20X CUTOUT DETAILS

TOLERANCES ARE +/- 0.01" [0.3mm] UNLESS STATED OTHERWISE

Figure 5.8 – TIU20X Cutout

CHAPTER 6: COMMUNICATIONS

6.1 PC to Operator Station Communications

The serial pin connections for transmit (Tx), receive (Rx) and ground are displayed below.

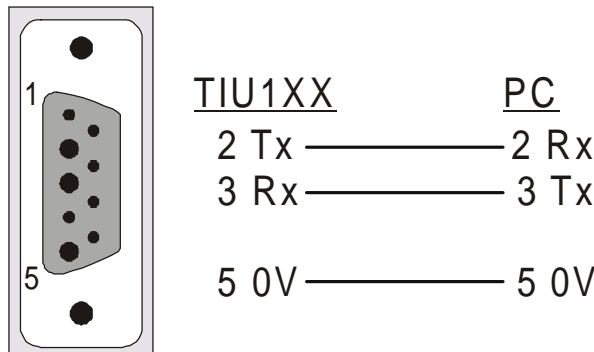

Figure 6.1 – PC Programming Serial Port & Connection Detail

6.2 Automation Equipment (AE) Communications Connections

6.2.1 Recommended Automation Equipment Communication Cables

Horner Electric recommends the following cables for automation equipment communication:

Belden No. 8105, 9807 or 9832 – General Purpose

Belden No. 8165 – Heavy Noise Environment

6.3 RS-232 Connection

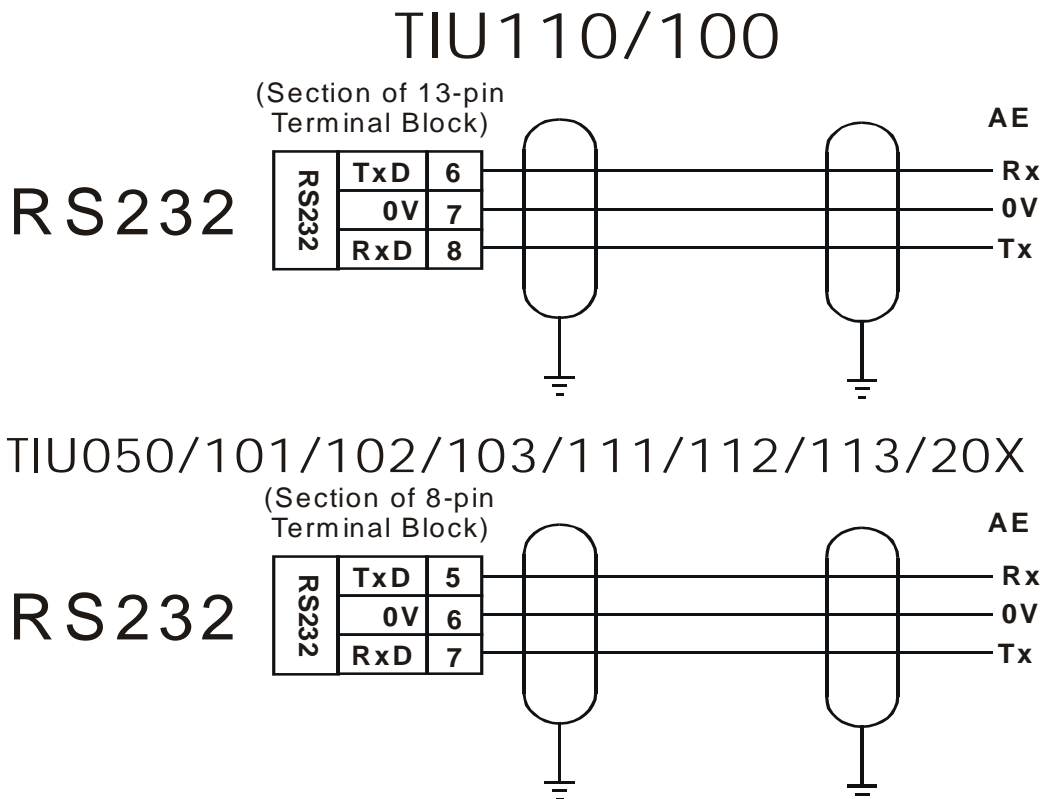

Figure 6.2 – RS-232 Connection

6.4 RS-422/485 Four-Wire

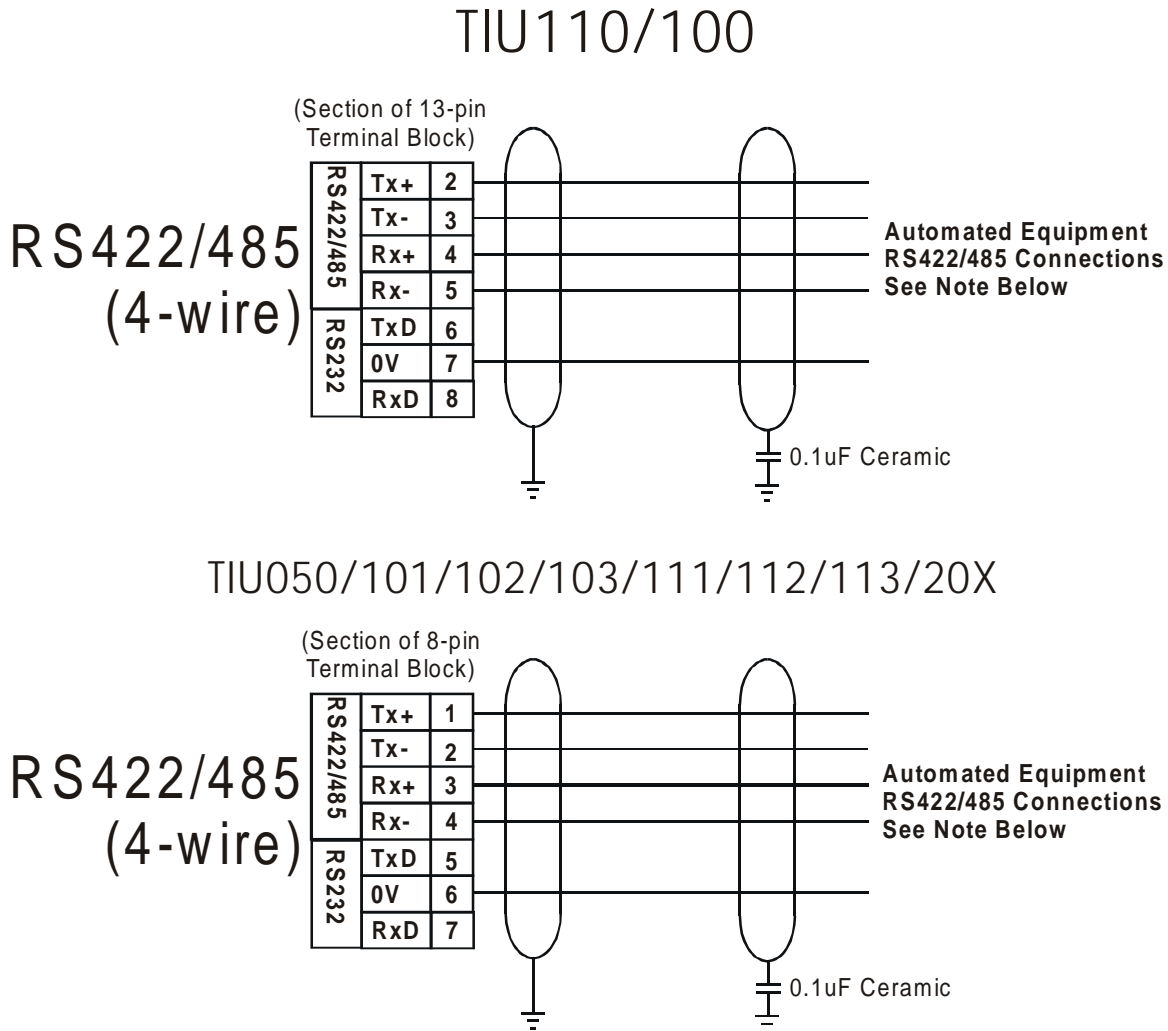

Figure 6.2 – RS-422/485 Four-Wire

Note: The descriptions used by different manufacturers for RS-422/485 connections vary. Please refer to the automation equipment manufacturers own manuals for connection details.

Note: Horner produces application notes explaining the connection to each of the different automated equipment manufactures. These application notes are ongoing, see your installation CD for any released documentation.

6.5 RS-485 Two-Wire

TIU110/100

RS422/485
(2-wire)

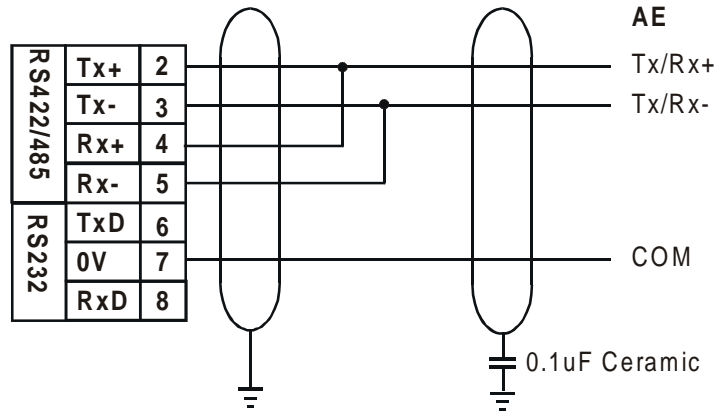

TIU050/101/102/103/111/112/113/20X

RS422/485
(2-wire)

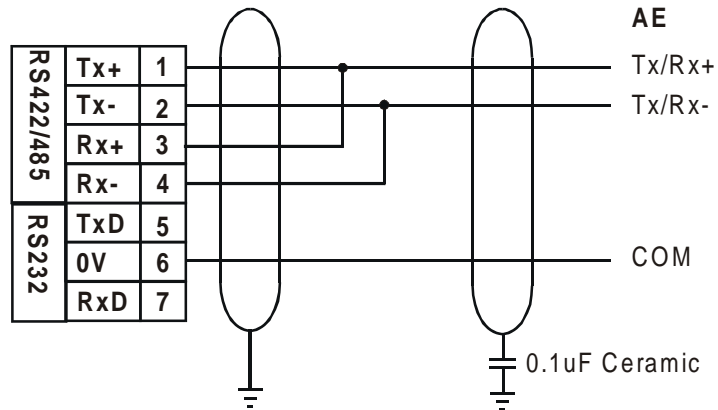

Figure 6.3 – RS-485 Two-Wire

6.6 Current Loop

The following diagram shows the connection to a device with an active 20mA current loop. The current loop on the TIU100/110 is passive. Either the PLC must provide the 20mA source or an external current source must be supplied.

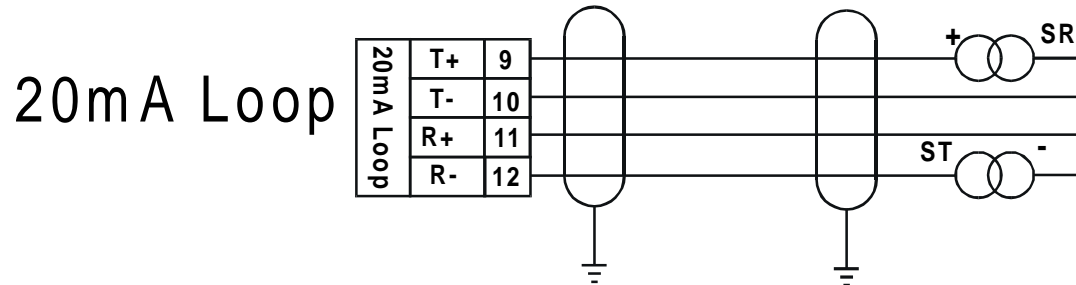

Figure 6.4 – Current Loop

Note: Current Loop is not a standard option on the TIU100/110. Current loop must be ordered specifically or can be re-fit into a standard unit. Contact a Horner Electric dealer for more information.

Note: Current Loop is not an option with the TIU050/101/102/103/111/112/113/20X.

CHAPTER 7: GETTING STARTED**7.1 Self-Test**

Power up the unit with the **UP** and **ENTER** keys pressed at the same time. The unit enters a self-test mode. The self-test consists of the following four checks:

7.1.1 Contrast Band

This test allows the user to set the lower and upper limits of contrast. Adjust the lower limit using the **UP** or **DOWN** key and press **Enter** when done. Do the same for the upper limit.

WARNING: - Changes to the lower or upper limits may allow the user to set the contrast to a setting where the display may appear blank. It is recommended that the factory setting are used (Min 8A, Max FE).

7.1.2 Display Test

The display test continuously blinks all pixels on (black) to off. Look for any pixels stuck on or off. Exit this test by pressing and holding any key for approximately two seconds.

7.1.3 Keyboard Test

As each key is pressed, an indication ******* appears above that key. In the case of units with a numeric keypad, press the key and a message appears indicating the key press. Check for keys indicating multiple presses or not reporting presses. Exit this test by pressing and holding any key for approximately two seconds.

7.1.4 RAM Test

Test either segment 0000 or segment 1000 (on the TIU100/110) of the RAM. The segment 1000 test performs a base 3 repeating test. This test detects shorted address lines and damaged memory bits. The segment 0000 test performs a Read-Modify-Write test on each byte of RAM, detecting damaged memory bits. Exit this test by selecting **DONE**.

7.1.5 Serial Loop-back Tests

Tests the PC port and the Serial Port in each of it's three modes for serial loop-back. Pre-made plugs are required to link the pins of a particular port. This takes the following form:

Port Tested	Product	Type of Connector	Pins to Short
PC (J2)	TIU100/110	Pin male D link connector	pin 2 to pin 3
RS-232 (J3)	TIU100/110	13-pin phoenix connection	pin 6 to pin 8
RS-422/485 (J3)	TIU100/110	13-pin phoenix connection	pin 2 to pin 4 and pin 3 to pin 5.
Current Loop	TIU100/110	13-pin phoenix connection	pin 1 to 9, pin 10 to 11 and pin 12 to 7
PC	TIU050/101/102/103/112/113/20X	Pin male D link connector	pin 2 to pin 3
RS-232	TIU050/101/102/103/112/113/20X	8-pin phoenix connection	Pin 5 to pin 7
RS-422/485	TIU050/101/102/103/112/113/20X	8-pin phoenix connection	Pin 1 to pin 3, Pin 2 to pin 4
NOTE: current loop in not installed on standard models, as such a standard model will fail the current loop-back test. Current Loop is <u>not</u> an option on the TIU050/20X.			

After starting the test, the OK counter begins to count up. Exit this test by selecting **DONE**.

7.2 Updating the Protocol

When the software is installed the user decides where the main CBREEZE folder resides. During installation the following folders are created: -

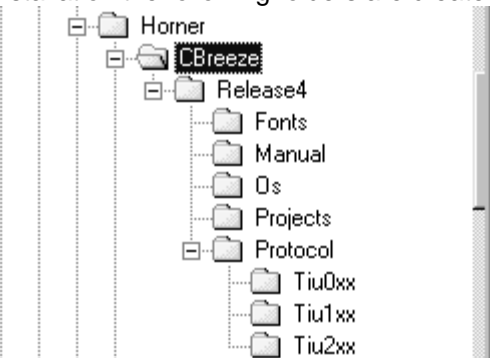

In the protocol directory 3 folders are created, TIU0xx, TIU1xx and TIU2xx. The protocol files for the different terminal is loaded into these folders. The protocol files for the TIU050 are loaded into Tiu0xx, the protocol files for the TIU10X are loaded into Tiu10x and the protocol files for the TIU20X are loaded into Tiu20x.

The name of the protocol file is broken up into three section, the protocol, the main software revision and the terminal type that protocol file is for.



Example

snp_R4.1xx

This is the protocol file for release 4 software for the GE FANUC PLC, for the TIU10X

df1_R4.2xx

This is the protocol file for release 4 software for Allen Brabley PLC, for the TIU20X

To Update Protocol File

1. Set Terminal Type
2. Set the required Automation Equipment in Communications Settings
3. Select **Update TIU Protocol** from the **F**ile menu.
4. Select the folder of the terminal you have connected to the PC. The correct file will appear for the terminal type selected and the Automation Equipment selected. Select that file and click OK.
5. A status bar appears indicating download progress.
6. After the transfer, the TIU050/10X/11X/20X resets itself. The correct PLC type is displayed on the TIU050/10X/11X/20X.
7. Next, the project loaded runs.

7.3 Updating the Operating System

1. Select **Update Operating System** from the **F**ile menu.
2. Choose the updated file with the "BIN" extension. Click **OK**.
3. A status bar appears indicating download progress.
4. During the download process, TIU050/10X/11X/20X displays the message "**SYSTEM SHUTDOWN**".

CHAPTER 8 : NETWORKS

8.1 Scope

This chapter gives a brief introduction into the networking hardware available on the Operator Station range. The part numbers of the various options are available in the Introduction Chapter of this manual. For information on programming the various network options see GFK-1818, User Manual for the **CBREEZE** Software.

8.2 Controller Area Network (CAN) Overview

The controller area network (or CAN bus) is a serial communications bus that was originally developed in the late 1980's by a German company (Robert Bosch) for use in the automotive industry. CAN is an ISO (International Standards Organisation) - defined serial communications bus for real-time applications. Established in 1947, the International Standards Organisation (ISO) is a multinational body dedicated to worldwide agreement on international standards. Specifically, CAN is documented in ISO 11898 (for high-speed applications) and ISO 11519 (for lower-speed applications).

8.2.1 CAN Features

CAN-based open automation technology successfully competes on the market of distributed automation systems because of the special features of the CAN protocol. The special features are CAN's producer-consumer-oriented (or peer-to-peer) principle of data transmission and its multi-master capability. The general design of CAN originally specified a high bit rate, high immunity to electrical interference and an ability to detect any errors produced. CAN networks have the following general attributes:

- Automatic error detection
- Easily configurable
- Cost-effective to design and implement
- Capable of operating in harsh environments

8.3 CsCAN Network Overview

The CsCAN Network was first developed in 1993 by Horner Electric. It was developed for use in a project that Horner Electric completed for the United States Post Office. Horner Electric developed its own network, because it needed a network that had a specific set of powerful peer-to-peer and host-to-node capabilities. The CsCAN Network has a "pass-through" feature whereby PC-based programs access other nodes connected to a network by passing the programming command through the serial port to the network port. (For a more detailed description, see below.) Horner Electric found that by developing its own network, it satisfied several important needs. Horner Electric continues CsCAN Network development to satisfy the requirements of today and the requirements of the future.

8.3.1 CsCAN Network Features

The CsCAN Network is based on CAN, which has many desirable features such as ruggedness, ease of configuration, etc. With Horner Electric Controllers, data is passed at 125Kbps using a differential pair of wires plus a ground. It is important to note that the data rate is not limited to 125Kbps. The maximum data rate is 1Mbps (limited by the speed of light). The CAN implementation in the CsCAN controller allows up to 64 controllers to be networked with no additional hardware and up to 253 controllers with three CAN repeaters.

For the programmer, little knowledge of networking procedures is needed. However for troubleshooting and optimizing, the following information is helpful. Instead of using master/slave or token passing, the hardware self-arbitrates based on the Network ID. **Controllers with lower Network ID numbers are given a higher priority than controllers with higher Network ID numbers.**

8.3.2 CsCAN Network Operation

When a controller needs to send data over the network, it first waits for the network to be idle (currently a maximum of 900uS). If two controllers start broadcasting information on the network at the same time, the

"self-arbitration" causes the controller with the greater Network ID number to cease broadcasting without affecting the message-in-progress of the other controller.

In applications with a large number of networked controllers, better results may be achieved by assigning lower Network IDs to controllers that have more critical network data than other controllers. By assigning higher Network IDs to controllers that provide numerous network updates, the controllers are prevented from monopolising the bus time.

Each controller is capable of broadcasting Global Digital Output bits (%QG) and Global Analog Output bits (%AQQ), which are periodically broadcasted to the other controllers on the network. The coil representations %QG and %AQQ may be used in **CBREEZE** like any other coil or internal register reference.

All digital global outputs are broadcast to the network each time one of them has a state change. In addition, if a controller has not transmitted its global data for specific time period, the controller's programmable network timer may expire, which in turn results in a global data broadcast. Finally, as part of its power-up initialisation sequence, another controller can explicitly request a controller to broadcast its global data.

8.4 DeviceNet Overview

DeviceNet is an open network. The specification and the protocol are open. Vendors are not required to purchase hardware, software or licensing rights to connect devices to a system.

8.4.1 DeviceNet Features

DeviceNet is a low-cost communications link to connect industrial devices. It allows the interchangeability of simple devices while making interconnectivity of more complex devices possible. DeviceNet is based on CAN. It is an application layer protocol (ISO layer 7) and is defined in terms of an abstract object model, which represents the available communication services and the external visible behaviour of a DeviceNet node.

The DeviceNet Model is application independent. DeviceNet provides the communication services needed by various types of applications. Many of today's lower level industrial control devices must retain their low cost/low resource characteristics even when directly connected to a network. DeviceNet takes this into consideration by defining a specific instance of the DeviceNet Model for communications typically seen in a Master/Slave application. This is referred to as the Predefined Master/Slave Connection Set. Some of the features and functionality of the DeviceNet network are described Table 8.1.

Table 8.1 - DeviceNet Features and Functionality									
Network Size	Up to 64 Nodes								
Network Length	Selectable end-to end network distance varies with speed								
	<table border="0"> <tr> <td>Baud Rate</td> <td>Distance</td> </tr> <tr> <td>125 Kbps</td> <td>500m (1,640 feet)</td> </tr> <tr> <td>250 Kbps</td> <td>250m (820 feet)</td> </tr> <tr> <td>500 Kbps</td> <td>100m (328 feet)</td> </tr> </table>	Baud Rate	Distance	125 Kbps	500m (1,640 feet)	250 Kbps	250m (820 feet)	500 Kbps	100m (328 feet)
Baud Rate	Distance								
125 Kbps	500m (1,640 feet)								
250 Kbps	250m (820 feet)								
500 Kbps	100m (328 feet)								
Data Packets	0-8 bytes								
Bus Topology	Linear (trunkline/dropline); power and signal on the same network cable								
Bus Addressing	Peer-to-Peer with Multi-Cast (one-to-many); Multi-Master and Master/Slave special case; polled or change-of-state (exception-based)								
System Features	Removal and replacement of devices from the network under power								

8.4.2 *DeviceNet Protocol*

Some of the communication protocol features of DeviceNet consist of the following:

1. A DeviceNet product can behave as a Client, a Server or both.
2. Master/Slave operation.
3. Capable of Peer-to-Peer exchange capability exists in which any DeviceNet product can produce and consume messages.
4. Capable of supporting 64 node addresses
5. Each node can support an unlimited number of I/O.

8.4.3 *DeviceNet Operation*

The following restrictions are placed on operations when using an OS that is configured as a DeviceNet slave.

1. Currently, communication between the PC and the controller is only possible to the device physically connected to the PCs' serial port. Project downloads, uploads, monitoring, and configuration **cannot currently take place** over a DeviceNet network.
2. The HE200CGM40x gateway card can not currently be used with DeviceNet communications. Horner Electric is providing a special Gateway device that is based on the OCS hardware. The Gateway device makes it possible to connect the PC serial port with the DeviceNet network.
3. DeviceNet network nodes are in a range from 0 to 63. The controller is able to observe network responses (polled connections) from any slave to the DeviceNet Master. The first 16-words of these observed responses are made available for mapping on the **Network Input Assignments** page. These correspond to the available nodes 0 to 63 and registers AQQ1 to AQQ16. Node 64 is used for a special case. When data is sent to a controller from a DeviceNet Master (via the polled connection) this data is mapped to node 64. Relative addressing is limited to -64 to +64.

8.5 CAN Wiring Rules

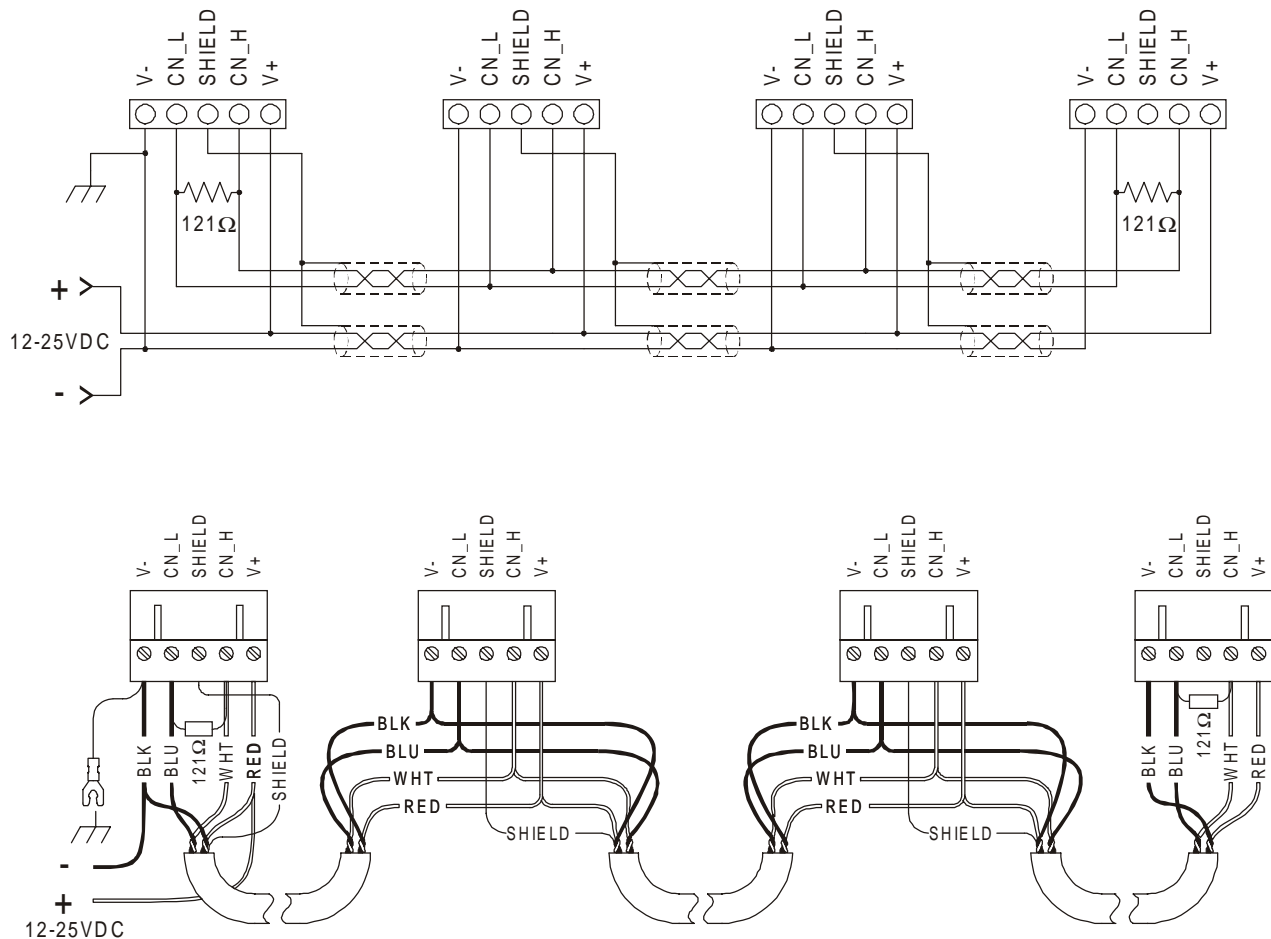

Figure 8.3 – CAN Network Cabling

1. Wire the CAN network in a daisy-chained fashion such that there are exactly two physical end-points on the network.
2. The two nodes at the physical end-points need to have 121 ohm 1% terminating resistors connected across the CN_L and CN_H terminals.
3. Use data conductors (CN_L and CN_H) that are 24 AWG shielded twisted pair for “thin cable” and 22 AWG shielded twisted pair for “thick cable”. They must also have 120-ohm characteristic impedance. In typical industrial environments, use a Belden wire #3084A (“thin”). Use #3082A (“thick”) for environments where noise is a concern.
4. Use power conductors (V- and V+) that are 18 AWG twisted-pair for “thin cable” and 15 AWG twisted-pair for “thick cable”.
5. Connect the V- power conductor to a good earth ground **at one place only** on the network, preferably physical endpoints.
6. For a section of cable between two nodes, the cable shield is connected to the cable shield input at *one end of the cable only*.
7. A CAN network (without repeaters) is limited to 64 nodes (with 63 cable segments) with a maximum cable length of 1500 ft.
8. Up to four CAN network segments, which adhere to the above rules, may be connected together using three CAN repeaters. In this manner, a CAN network may be extended to 253 nodes with a total cable distance of 6000 ft.

8.6 Profibus

Profibus utilises a Master-Slave type of communication with the TIUXX2 functioning as a slave device. Decentralised Peripherals (Slave) Baud rates of up to 12 MBd can be obtained through Profibus.

Up to 32 devices (9master or slaves) can be connected in one segment without using repeaters, or up to 64 devices can be connected using repeaters.

Master devices are used to determine the data communication on the bus. One master can service several slaves. Several Masters can participate on the bus simultaneously, but only one Master can write outputs to a slave.

The slave devices are peripheral devices. Slaves do not have bus access rights and can only acknowledge received messages or send messages to the master when requested to do so. Any master can read data from the slave devices. All connected Slaves have the same priority.

For further information on the Profibus Network, visit their website at www.profibus.com

8.6.1 Profibus Wiring

The TIUXX2 uses a 9 pin D-sub plug connector for its Profibus port. The pin assignment of the plug connector and the wiring are show below.

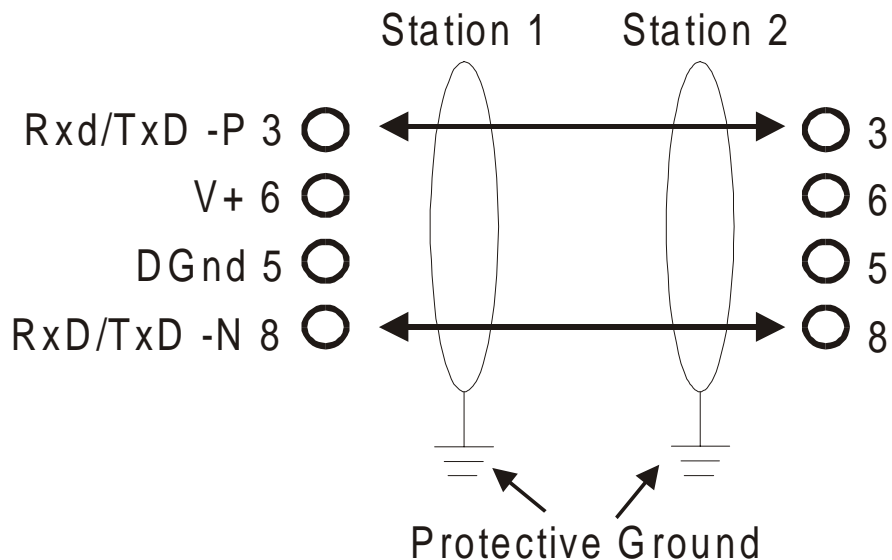

Figure 8.4 Profibus Port Pinout

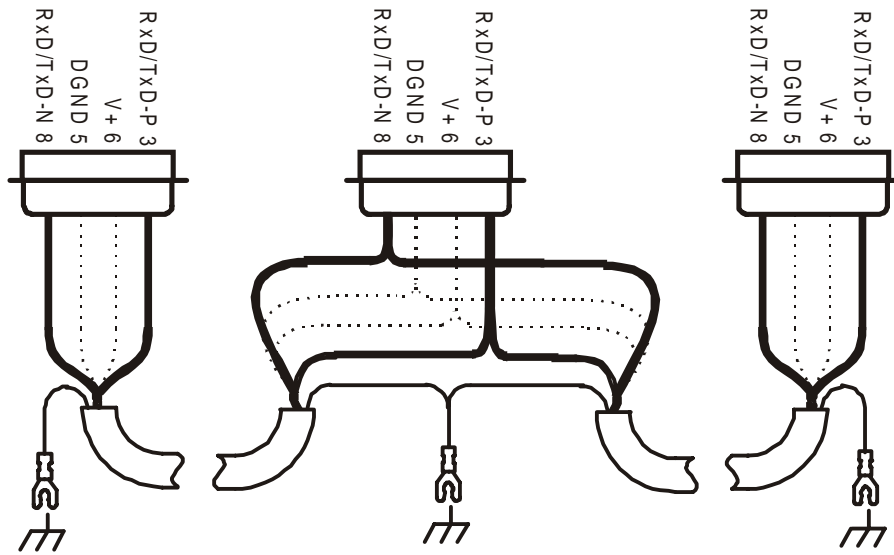

Figure 8.5 – Profibus Network Cabling

Its is necessary to terminate both ends of the network. Both terminations must have power to them to insure proper operation of the network. The following diagram illustrates the correct connection for the termination resistors.

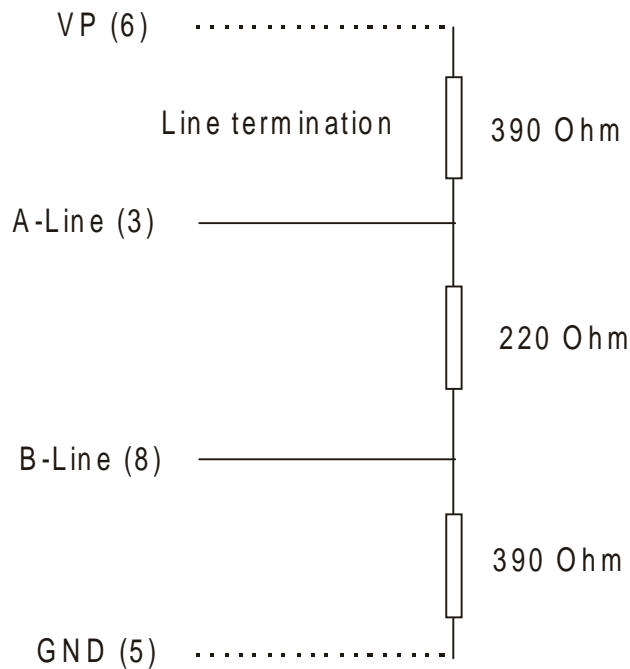

Figure 8.6 – Profibus termination resistors

CHAPTER 9: SMARTSTACK™

9.1 Scope

Horner has now added the SmartStack™ modules from the OCS Range to the TIU20X range. The SmartStack system is a method of allowing I/O expansion on an HMI. A wide range of modules is available including Digital and Analogue.

9.2 Installing and Removing a SmartStack Module

The following section describes how to install and remove a SmartStack Module.

Caution: To function properly and avoid possible damage, do not install more than four Smart Stack™ Modules per TIU20X.

9.2.1 Installing SmartStack Modules

1. Hook the tabs. Each SmartStack Module has two tabs that fit into slots located on the TIU20X. (The slots on the TIU20X are located on the back cover.)
2. Press the SmartStack Module into the “locked” position, making sure to align the SmartStack Module fasteners with the SmartStack receptacles on the TIU20X.

9.2.2 Removing SmartStack Modules

1. Using a Flathead screwdriver, pry up the end of the SmartStack Module (opposite of tabs) and swing the module out.
2. Lift out the tabs of the module.

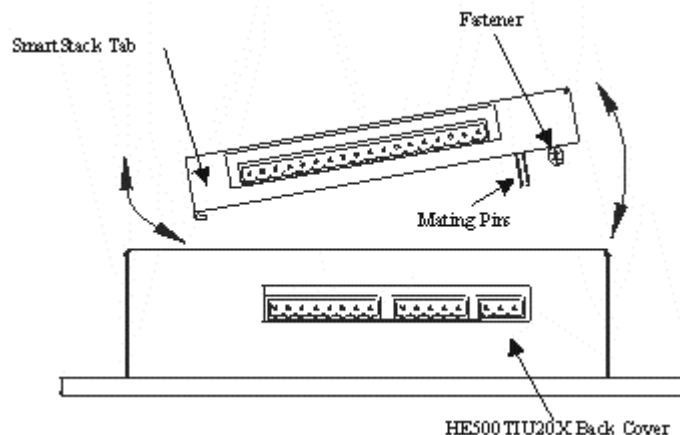

Figure 9.1 – Installing a SmartStack™ Module in an OCS.

NOTES