

INSTALLATION AND OPERATING INSTRUCTIONS

Raytherm™
Type H

RESIDENTIAL BOILERS

Models

0030B, 0042B, 0066B, 0090B
0135B, 0180B



FOR YOUR SAFETY

Do not store or use gasoline or other flammable vapors and liquids or other combustible materials in the vicinity of this or any other appliance. To do so may result in an explosion or fire.

WARNING: Improper installation, adjustment, alteration, service or maintenance can cause property damage, personal injury or loss of life. Refer to the user's information manual provided with this boiler. Installation and service must be performed by a qualified installer, service agency or the gas supplier.

FOR YOUR SAFETY

WHAT TO DO IF YOU SMELL GAS

- *Do not try to light any appliance.
- *Do not touch any electrical switch; do not use any phone in your building.
- *Immediately call your gas supplier from a neighbor's phone. Follow the gas supplier's instructions.
- *If you cannot reach your gas supplier, call the fire department.

THIS MANUAL SHOULD BE MAINTAINED IN LEGIBLE CONDITION AND KEPT ADJACENT TO THE BOILER OR IN A SAFE PLACE FOR FUTURE REFERENCE.



Raypak®

A Rheem® Company

Contents

RECEIVING EQUIPMENT.....	3
GENERAL SPECIFICATIONS.....	3
INSTALLATION PROCEDURES.....	4
Code Requirements.....	4
Mounting Base.....	4
ClearanceRequirments.....	4
Combustion/Ventilation Air.....	4
Venting Connections.....	5
Vent Damper Installation.....	7
Gas Supply Connections.....	11
Water Connections & System Piping.....	11
Piping Diagrams.....	12
Electrical Wiring.....	15
Wiring Diagrams.....	16
SERVICING PROCECURES.....	23
General Locations of Controls.....	23
Sequence of Operation.....	23
Start-Up Procedures.....	24
Shut-Down Procedure.....	26
Safe Shutdown Test.....	28
Inspection Procedures.....	28
Repair Procedures.....	29
TROUBLE SHOOTING GUIDE.....	31
Adjustments/Replacements of Components.....	33
REPLACEMENT PARTS LIST.....	34

CALIFORNIA PROPOSITION 65 WARNING: This product contains chemicals known to the State of California to cause cancer, birth defects or other reproductive harm.

These instructions are provided to assure the proper installation and operation of Raypak boilers. Should questions arise regarding the specifications, installation, operation or servicing of these boilers, we suggest that the local Sales representative or the factory be consulted.

RECEIVING EQUIPMENT

On receipt of your equipment, visually check for external damage to the carton. If the carton is damaged, it is suggested that a note be made on the Bill of Lading when signing for the equipment. Remove the boiler from the carton, and if it is damaged, **report the damage to the carrier immediately**. Be sure that you receive the number of packages indicated on the Bill of Lading. **Claims for shortages and damages must be filed with carrier by consignee.**

Purchased parts are subject to replacement only under the manufacturer's warranty. Debits for defective replacement parts will not be accepted and defective parts will be replaced in kind only per our standard warranties.

When ordering parts, you must specify Model and Serial Number of boiler. When ordering under warranty conditions, you must also specify date of installation.

Raypak recommends that this manual be reviewed thoroughly before installing the boiler. If there are any questions which this manual does not answer, please contact your local Raypak representative.

GENERAL SPECIFICATIONS

Raytherm hydronic boilers are design certified and tested under the requirements of the American National Standard, **ANSI Z21.13**. Each boiler has been constructed and pressure tested in accordance with the requirements of Section IV of the American Society of Mechanical Engineers Code, and factory fire tested.

The boilers are designed for indoor installation with a built-in draft hood, and a built-in sub-base for combustible flooring. Models are available with standing pilot, or with intermittent ignition device (I.I.D.). The boilers are equipped with the following components: water circulation pump, pressure relief valve, temperature/pressure gauge, adjustable high limit switch, drain valve, fast response temperature sensor, 40 VA transformer, pump relay, vent thermal switch, flame roll-out switch, and redundant combination gas valve. Two-stage gas valve (50% firing on first stage) is standard on models H-0090, H-0135 and H-0180.

The automatic ignition models and some standing pilot models are provided with a plug-in connector that is compatible with the Honeywell D80D vent damper. Similar type vent dampers made by other manufacturers, and design certified by a nationally-recognized testing agency, under the ANSI Z21.66 standards, may also be used.

Follow the installation instructions furnished with the vent damper package. The plug-in connector can also be used with power venters. Refer to the specific installation instructions supplied by the power vent manufacturer.

SPECIFICATIONS AND DIMENSIONS

MODEL	INPUT MBH	HEATING CAPACITY MBH	NET I=B=R RATING	PIPING CONNECTIONS		A	B	C	K VENT DIA.
				WATER NPT.	GAS NPT.				
H-0030	30	25	22	1"	1/2"	11"	5 3/4"	5 1/2"	4"
H-0042	42	35	30	1"	1/2"	11"	5 3/4"	5 1/2"	4"
H-0066	66	54	47	1"	1/2"	11"	5 3/4"	5 3/4"	5"
H-0090	90	74	64	1"	1/2"	11"	5 3/4"	5 3/4"	5"
H-0135	135	109	95	1 1/4"	1/2"	18"	6 1/4"	6 1/4"	6"
H-0180	180	148	129	1 1/4"	1/2"	18"	6 1/4"	8.0"	7"

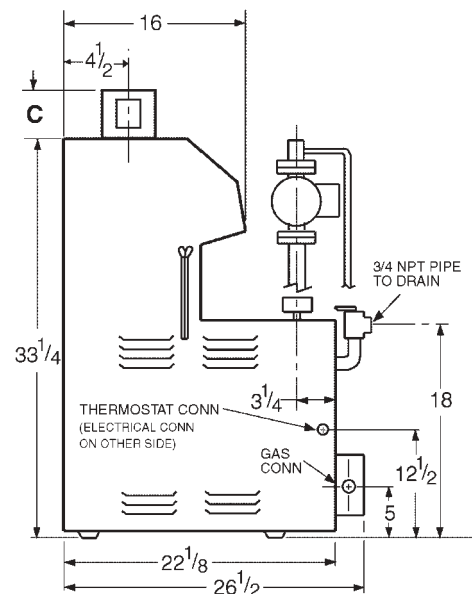
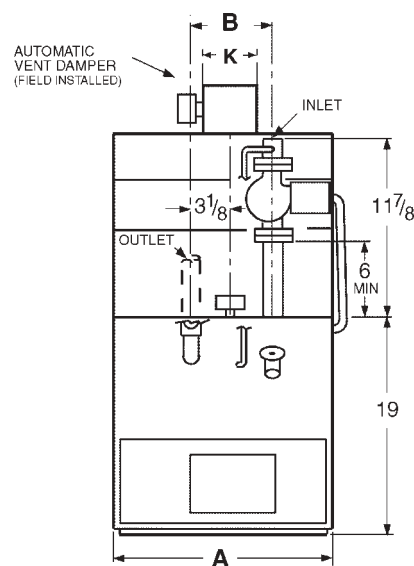

Fig. #8978.1

3. INSTALLATION PROCEDURES

CODE REQUIREMENTS

Installation must be in accordance with **local codes**, or, in the absence of local codes, with the latest editions of the **National Fuel Gas Code, ANSI Z223.1**, and the **National Electrical Code, ANSI/NFPA 70**. In Canada, installations must conform with the current **CAN/CGA B149.1** or **.2** and the **Canadian Electrical Code Part 1 CSA C22.2 No.1**. Where required by the authority having jurisdiction, the installation must conform to American Society of Mechanical Engineers Safety Code for Controls and Safety Devices for Automatically Fired Boilers, **No. CSD-1**.

MOUNTING BASE

Boiler should be mounted on a level surface. Each boiler is designed with a built-in sub-base approved for mounting the boiler on combustible flooring. Boiler must **NOT** be installed on carpet flooring.

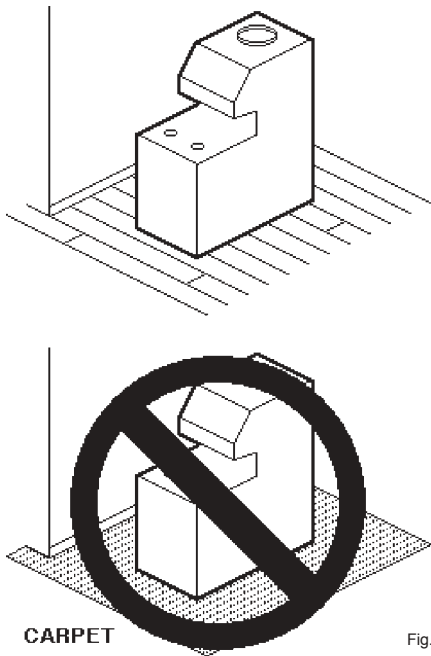

Fig.#8196

NOTE: The boiler should be located in an area where water leakage will not result in damage to the area adjacent to the appliance or to the structure. When such locations cannot be avoided, it is recommended that a suitable drain pan, adequately drained, be installed under the appliance. The pan must not restrict air flow.

In addition, the boiler shall be installed such that the gas ignition system components are protected from water (dripping, spraying, rain, etc.) during appliance operation and service (circulator replacement, control replacement, etc.)

CLEARANCEREQUIREMENTS

1) Minimum Clearances From Combustible Materials

Model No.	Floor	Front	Back	Right	Left	Top	Flue Vent
0030 0042 0066	Comb.	4"	6"	6"	6"	16"	6"
0090 0135 0180	Comb.	Alcove	6"	6"	6"	16"	6"

2) A front clearance of at least 24" is recommended for adequate service of burner-tray and controls.

3) Except for carpeted flooring, boilers are certified for installation on combustible floors.

4) For un-insulated hot water pipes, maintain a 2" clearance, or consult local authority having jurisdiction.

COMBUSTION/VENTILATION AIR

WARNING: Air supply to the boiler room must not be affected by mechanical exhaust vents located in other parts of the house, such as kitchen or bathroom fans, or attic blowers. Mechanical exhaust vents may create a negative pressure condition in the boiler room that can become a hazard of asphyxiation, explosion or fire.

CAUTION: Combustion air must not be contaminated by corrosive chemical fumes which can damage the boiler. Measures must be taken to prevent the entry of corrosive chemical fumes to the combustion and ventilation air supply. Such chemicals include, but are not limited to, chlorinated and/or fluorinated hydrocarbons such as found in refrigerants, aerosol propellants, dry-cleaning fluids, degreasers, and paint removers. Other harmful elements may come from bleaches, air fresheners, or mastics. Vapors from these types of products can form corrosive acid compounds when burned in a gas flame. The resulting acid condensate can damage or substantially reduce the life of the heater. It may be necessary to provide outside air directly to the heater in order to avoid this problem.

1) The boiler must be provided with adequate supply of air for proper combustion and ventilation in accordance with **Sec. 5.3**, of the latest edition of the **National Fuel Gas Code, ANSI Z223.1**, or applicable provisions of the local building codes.

- 2) When the boiler is installed in a confined space such as a utility room or closet (Models 0030,0042 and 0066 only), where all air is supplied from inside the building, the boiler room must be provided with **two** openings, each one having a minimum net free area, in square inches as follows:

Model	Sq. In. of Free Area
0030, 0042 & 0066	100

One opening shall be within 12" of the top, and the other opening within 12" of the floor. If additional gas appliances are installed in the same space, the total input of all gas appliances installed in the same space, must be considered in the calculation. Refer to Sec. 5.3.5 of the latest edition of the National Fuel Gas Code for additional requirements.

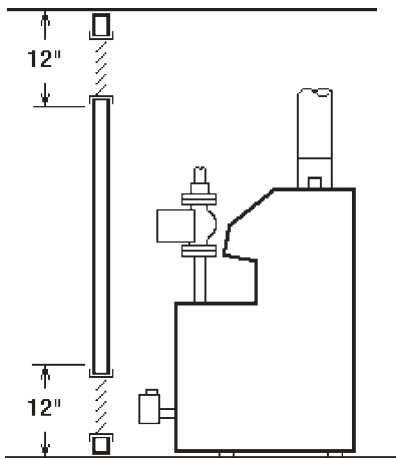

Fig. #8198.0

NOTE: If louvers, grills or screens are used on the openings, obtain the net free area requirements from their supplier or manufacturer. If the design free area of a louver is not known nor available, it shall be assumed that **wood** louvers will have **20-25** percent free area and **metal** louvers will have **60-75** percent free area as shown in Sec. 5.3.5 National Fuel Gas Code.

- 3) If the boiler room is located against an outside wall and air openings can communicate directly with the outdoors, the two openings on the outside wall must each have a net free area as follows:

Model	(Sq. In.) Net Free Area
0030 & 0042	12
0066	18
0090	24
0135	35
0180	45

Location of the openings is the same as in the previous case - that is, within 12" of the top, and within 12" of the bottom of the enclosure. If horizontal ducts are used, the area must be doubled and the duct area shall not be less than the area of the openings they connect, and in no case shall the smallest dimension be less than 3".

VENTING CONNECTIONS

These boilers have built-in drafthoods. Vent piping the same size or larger than the drafthood outlet is recommended; however, when the total vent height (drafthood outlet to vent terminal) is at least ten (10) feet, the vent pipe size may be reduced by one size only as specified in Chapter 10 of the latest edition of the National Fuel Gas Code, **ANSI Z 223.1**. As much as possible, avoid long horizontal runs of vent pipe and too many elbows. If installation requires horizontal runs, the vent pipe must have a minimum of 1/4 inch per foot rise and should be supported at not less than five foot intervals. Maximum vent connector horizontal length shall be 1-1/2 feet (18 inches) for each inch of connector diameter as follows.

Model	Vent Connector Diameter	Max Horizontal Length - FT
30 & 42	4"	6'
66 & 90	5"	7.5'
135	6"	9'
180	7"	10.5'

Gas vents supported only by the flashing and extending above the roof more than five feet should be securely guyed or braced to withstand snow and wind loads. We recommend use of insulated vent pipe spacer through the roofs and walls.

For protection against rain or blockage by snow, the vent pipe must terminate with a listed vent cap which complies with the local codes or, in the absence of such codes, to the latest edition of the National Fuel Gas Code, **ANSI Z 223.1**.

The discharge opening must be a minimum of two feet vertically from the roof surface and at least two (2) feet higher than any part of the building within ten (10) feet. Vent stack shall be at least five (5) feet in vertical height above the drafthood outlet. The vent cap location shall have a minimum clearance of four (4) feet horizontally from, and in no case above or below, unless a 4-foot horizontal distance is maintained, from electric meters, gas meters regulators and relief equipment.

The weight of the vent stack or chimney must not rest on the boiler's draffhood. Support must be provided in compliance with applicable codes. The boiler top and draffhood must be readily removable for maintenance and inspection. Vent pipe should be adequately supported to maintain proper clearances from combustible construction.

Type "B" double-wall (or equivalent vent pipe is recommended. However single-wall metal vent pipe may be used as specified in the latest edition of the National Flue Gas Code **ANSI Z 223.1**.

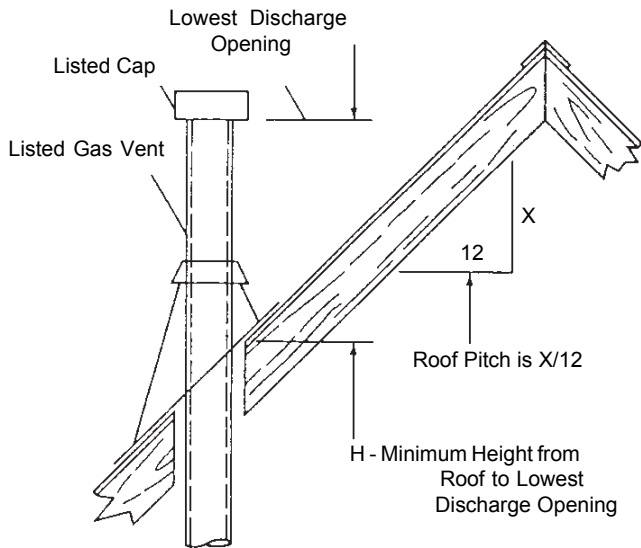

Roof Pitch	H (Min. Ft.)
Flat to 6/12	1.0
6/12 to 7/12	1.25
Over 7/12 to 8/12	1.5
Over 8/12 to 9/12	2.0
Over 9/12 to 10/12	2.5
Over 10/12 to 11/12	3.25
Over 11/12 to 12/12	4.0
Over 12/12 to 14/12	5.0
Over 14/12 to 16/12	6.0
Over 16/12 to 18/12	7.0
Over 18/12 to 20/12	7.5
Over 20/12 to 21/12	8.0

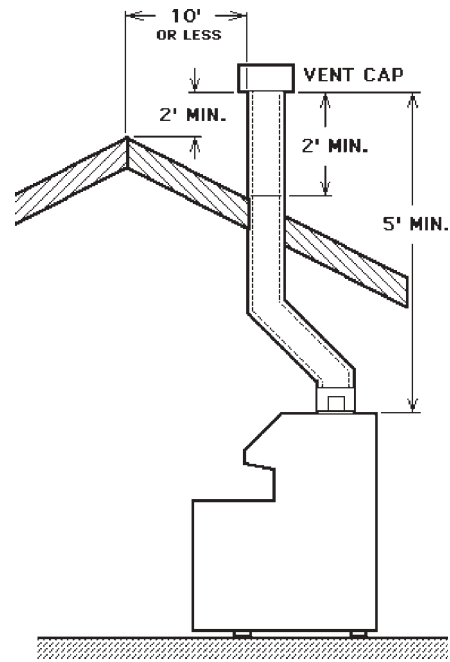

Fig.#8191

WARNING: These boilers must not be connected into any portion of mechanical draft systems operating under positive pressure. To do so may cause the flue products to be discharged into the living space causing serious health injury.

For connections to gas vents or chimneys, vent installations shall be in accordance with Part 7, Venting of Equipment, of the National Fuel Gas Code, **ANSI Z223.1**, or applicable provisions of the local building codes.

COMMON VENTS

Manifolds that connect more than one boiler to a common chimney must be sized to handle the combined load. Consult available guides for proper sizing of the manifold and the chimney. **At no time should the area be less than the area of the largest outlet.**

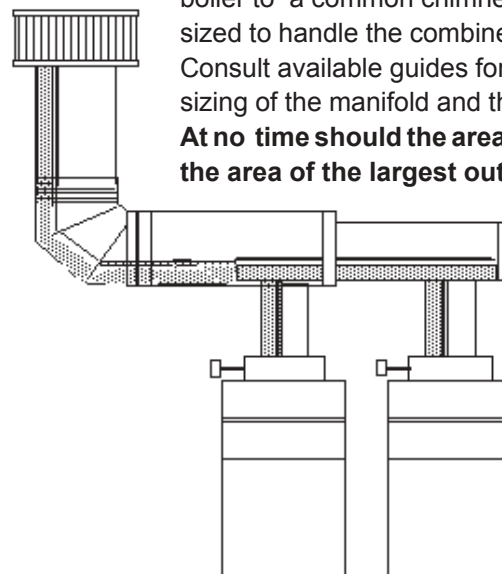

Fig. #9001

At the time of removal of an existing boiler, the following steps shall be followed with each appliance remaining connected to the common venting system placed in operation, while the other appliances remaining connected to the common venting system are not in operation.

- (a) Seal any unused openings in the common venting system.
- (b) Visually inspect the venting system for proper size and horizontal pitch and make sure there is no blockage or restriction, leakage, corrosion and other deficiencies which could cause an unsafe condition.
- (c) Insofar as is practical, close all building doors and windows and all doors between the space in which the appliances remaining connected to the common venting system are located and other spaces of the building. Turn on clothes dryers and any appliance not connected to the common venting system. Turn on any exhaust fans, such as range hoods and bathroom exhausts, so they will operate at maximum speed. Do not operate a summer exhaust fan. Close fireplace dampers.
- (d) Place in operation the appliance being inspected. Follow the lighting instructions. Adjust thermostat so appliance will operate continuously.
- (e) Test for spillage at the draft hood relief opening after 5 minutes of main burner operation. Use the flame of a match or candle, or smoke from a cigarette, cigar or pipe to visually check spillage.
- (f) After it has been determined that each appliance remaining connected to the common venting system properly vents when tested as outlined above, return doors, windows, exhaust fans, fireplace dampers and any other gas burning appliance to their previous conditions of use.
- (g) Any improper operation of the common venting system should be corrected so that the installation conforms with the latest edition of the National Fuel Gas Code, ANSI Z 223.1. When resizing any portion of the common venting system, the common venting system should be resized to approach the minimum size as determined using the appropriate tables in Chapter 10 and in Appendix G of the National Fuel Gas Code, ANSI Z 223.1 and CAN/CGA - B149.1 - B149.2.

VENT DAMPER INSTALLATION

LOCATION

The vent damper supplied with each boiler must be located in the vent so that it serves only the appliance for which it is intended.

If improperly installed, a hazardous condition, such as an explosion or carbon monoxide poisoning, could result. Make certain that it is mounted in an accessible location at least 6 in. (152.4 mm) from any combustible material or the heat exchanger and that the position indicator is in a visible location.

The vent damper **must be installed** at the appliance draft hood, and **without** modification of the draft hood.

To connect the vent damper wiring to the boiler wiring, remove the jumper from the circuit plug. (See wiring diagram) Connect the damper circuit plug to the boiler circuit plug.

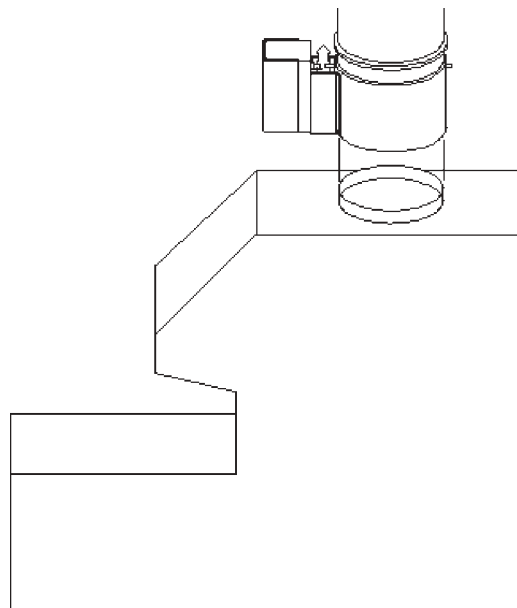

Fig. #8642

WARNING: Read carefully and follow the installation instructions furnished with the vent damper package. Failure to follow these instructions can cause asphyxiation, explosion or fire.

MOUNTING

On vertical vents, the vent damper may be mounted with the actuator in any position. On horizontal vents, **do not** mount the actuator either directly above or directly below the vent pipe; mount the vent damper actuator to the side of the vent.

The vent damper is set up for a continuous pilot system. If the vent damper is installed on a system with an Intermittent Pilot or Hot Surface Ignition the energy savings of the vent damper can be improved by plugging the hole in the vent damper blade using the knockout plug, Part No. 105612R, provided in the parts envelope.

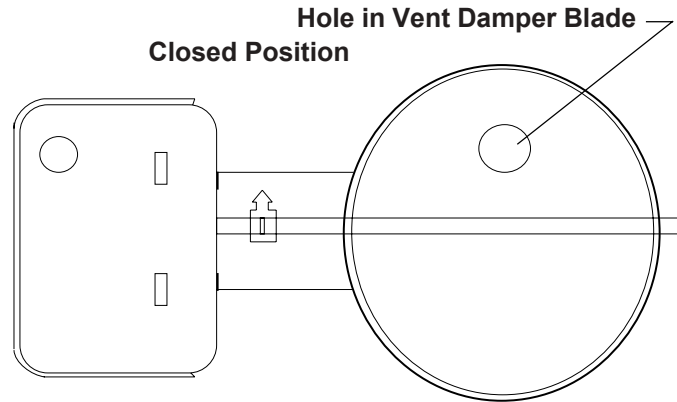

Fig. #8994

DO NOT plug the hole if installing the vent damper on a continuous pilot system as this will create a hazardous condition.

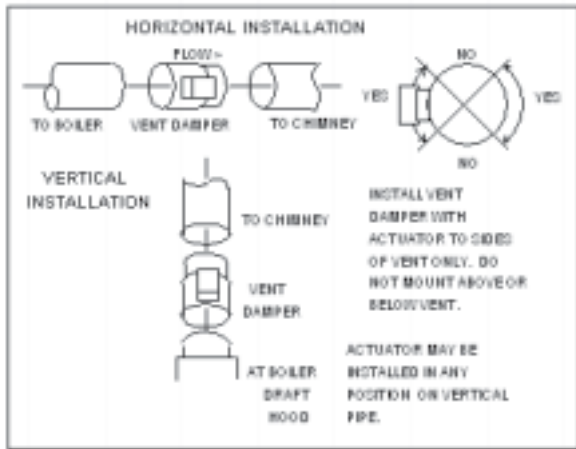

Fig. #8183.0

INSTALLING THE VENT DAMPER IN HORIZONTAL & VERTICAL VENT.

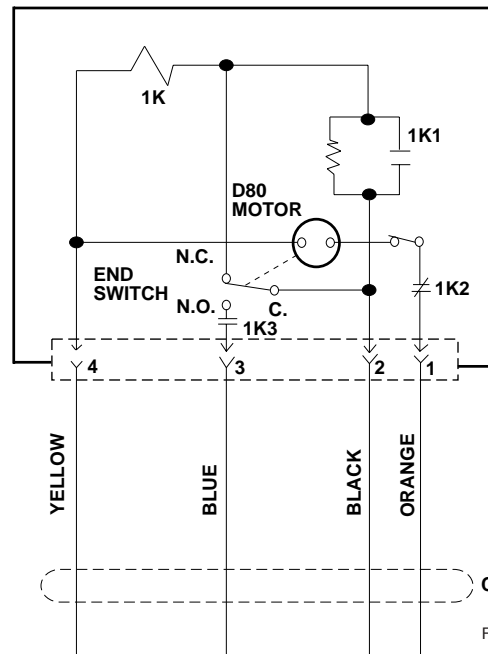

Fig. #152323

D80D GENERAL WIRING DIAGRAM

INSTALL THE VENT DAMPER TO SERVICE ONLY THE SINGLE APPLIANCE FOR WHICH IT IS INTENDED. IF IMPROPERLY INSTALLED, A HAZARDOUS CONDITION, SUCH AS AN EXPLOSION OR CARBON MONOXIDE POISONING, COULD RESULT.

VENT DAMPER OPERATION

For safe, efficient operation, the vent damper and all flue-product-carrying areas of the appliance must be checked annually, with particular attention given to deterioration from corrosion or other sources. Check vent damper operation as follows:

1. When the boiler is off, check that the vent damper position indicator points to the closed position, below.

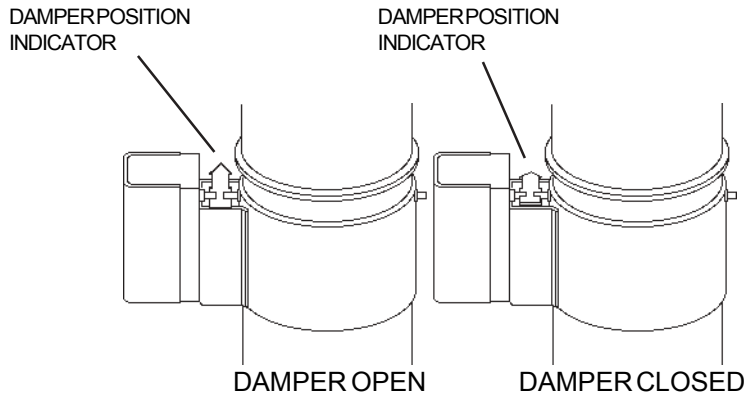

NOTE: To place vent damper in the open position to allow burner operation:
Turn the power off. Turn the damper blade to fully open position (arrow facing same direction as vent pipe). Turn power on.

Fig. # 8181.0

VENT DAMPER POSITION INDICATOR

2. Turn the thermostat or controller up to call for heat and check that the vent damper indicator points to the open position, below.
3. Turn the thermostat or controller down again and check that the vent damper position indicator returns to the closed position.

THE VENT DAMPER MUST BE INSPECTED AT LEAST ONCE A YEAR BY A TRAINED, EXPERIENCED SERVICE TECHNICIAN. THE NAME OF THE PERSON WHO ORIGINALLY INSTALLED YOUR VENT DAMPER IS SHOWN ON THE INSTALLATION LABEL. DAMPER MUST BE IN OPEN POSITION WHEN BOILER MAIN BURNERS ARE OPERATING.

FLAIR DAMPER SYSTEM SCHEMATIC

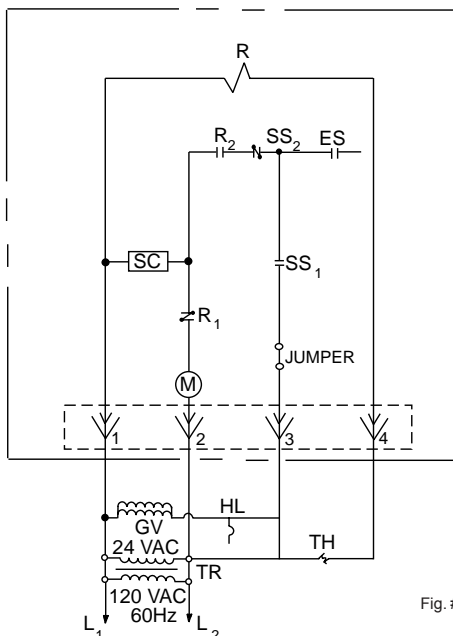

Fig. #9002

LEGEND

- M - Damper motor
 - R - Relay
 - ES - End switch
 - SS1 - N/C Safety switch
 - SS2 - N/O Safety switch contacts
 - TR - Transformer 120/24V
 - HL - High limit
 - GV - 24V gas valve*
 - TH - Thermostat, heating, low voltage
 - J - Jumper
- Note: Circuit shown with damper in closed position, no call for heat.

LADDER DIAGRAM

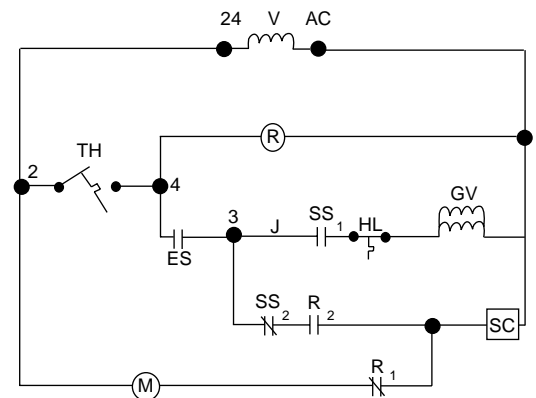
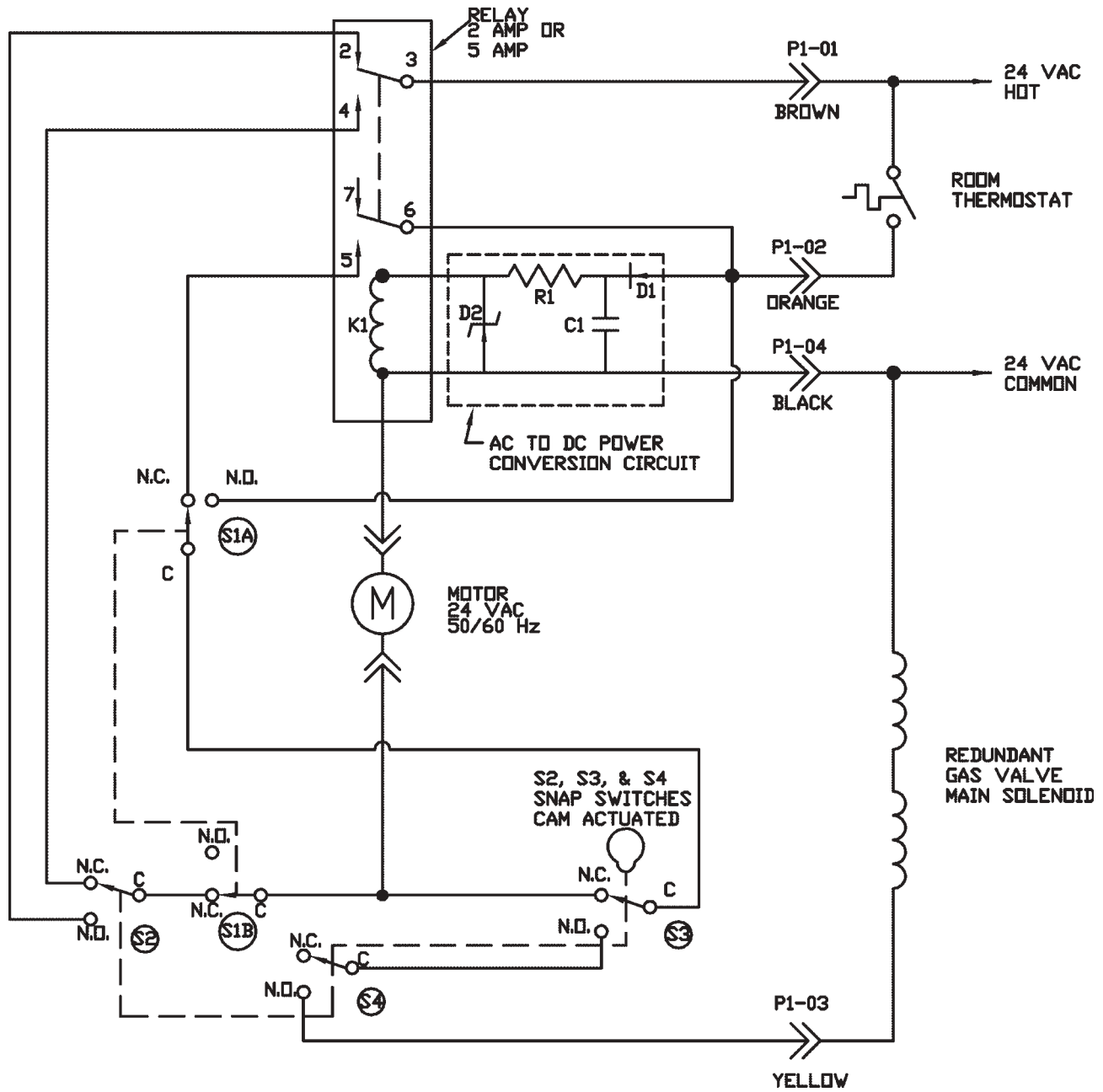

Fig. #9003

CONNECTION DIAGRAM

EFFIKAL RVGP



GAS SUPPLY CONNECTIONS

The inlet gas connection of the boiler gas valve is 1/2". Provide an adequate gas piping supply line no smaller than 1/2", according to the chart below:

Maximum Equivalent Pipe Length (Feet)

MODEL	1/2" Pipe		3/4" Pipe		1" Pipe		1 1/4" Pipe	
	NAT	PRO	NAT	PRO	NAT	PRO	NAT	PRO
0030 & 0042	125	350	500	-	-	-	-	-
0066	60	160	175	460	-	-	-	-
0090	30	80	125	300	400	-	-	-
0135	15	40	60	150	200	450	-	-
0180	-	20	35	90	115	300	425	-

Gas piping must have a sediment trap ahead of the boiler gas controls, and a manual shut-off valve located outside the jacket. All gas piping should be tested after installation in accordance with local codes.

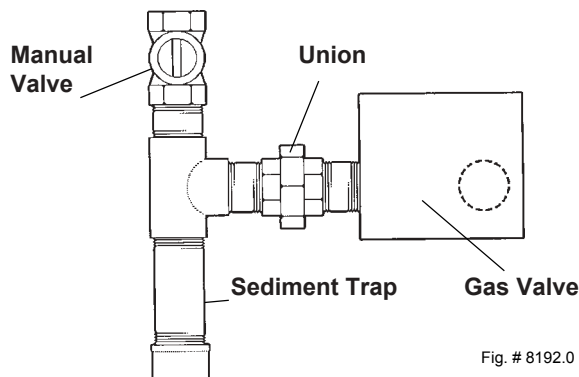

CAUTION: The boiler and its manual shut-off valve must be disconnected from the gas supply during any pressure testing of that system at test pressures in excess of 1/2 psig (3.45 KPA). Dissipate test pressure in the gas supply line before reconnecting the boiler and its manual shut-off valve to gas supply line. FAILURE TO FOLLOW THIS PROCEDURE MAY DAMAGE THE GAS VALVE. OVER PRESSURED GAS VALVES ARE NOT COVERED BY WARRANTY. The boiler and its gas connections shall be leak tested before placing the appliance in operation. Use soapy water for leak test. DO NOT use open flame.

NOTE: Do not use teflon tape on gas line pipe thread. A flexible sealant suitable for use with Natural and Propane gases is recommended.

These boilers are also certified to operate on propane gas, when equipped with the combination gas valve and orifices (pilot and main burners) sized for propane gas.

GAS PRESSURE

	Inches	W.C.	Regulator
	Min.	Max.	Setting
Natural	7.0	14.0	3.5
Propane	12.0	14.0	11.0

The gas valve is provided with pressure taps to measure gas pressure upstream of the gas valve and downstream which is the same as the manifold pressure.

WATER CONNECTIONS & SYSTEM PIPING

The pipe size for water connections is shown on page 3. Typical piping systems are shown on pages 12 to 14.

The boiler is supplied with a circulator and built in bypass as standard to ensure the required minimum water flow in the boiler. The bypass on models H-0135 and H-0180 is provided with an adjustable valve that is factory-set in the full open position. The handle is shipped loose. The full open position is appropriate for most systems, and ensures adequate flow through the boiler. If system flow is inadequate, (indicated by excessive temperature drop through the system) the bypass valve can be throttled slightly. Care must be taken against over-throttling which may lead to inadequate flow through the boiler and boiler harmonics (a humming sound from the heat exchanger). If adequate system flow cannot be obtained without causing harmonics, an additional pump is required. The factory-mounted circulator will provide adequate water flow for systems designed at a 20°F temperature drop, and system pressure drop or head not exceeding that which is shown below.

Models	System Flow (GPM)	Maximum System Head (Ft/Wtr)
H-0030	2.5	9.0
H-0042	3.5	8.0
H-0066	5.3	8.5
H-0090	7.3	6.5
H-0135	11.0	10.0
H-0180	14.6	7.0

When the total system head exceeds the available head pressures, a primary/secondary pumping system is recommended.

The minimum boiler operating temperature should be 105°F. When operating at low temperature applications, ΔT (temperature rise) must be 20°F or less.

Propylene glycol solution is commonly used in the heating system when freeze protection is required. This will affect the system design and pump performance. As a rule of thumb, 50% solution of propylene glycol will require the system flow (GPM) to increase by 14%, and the system head (Ft/Wtr) by 23% in order to maintain the same heat transfer load.

Systems with multiple zones may require an additional circulator. Consult manufacturer's data for valve pressure drops. When an indirect water heating system is used, it is recommended that a separate circulator be installed to meet the required flow and pressure drop conditions of the indirect water heater.

We recommend that the make-up water from the cold water line have a check valve, gate valve, and feedwater regulator set at 12 psig. Install unions and gate or ball valves at inlet and outlet connections at the boiler to facilitate servicing.

The pressure relief valve is mounted on the boiler and must be piped to a drain. We recommend that all high points be vented and that purge valves be installed. A boiler installed above radiation level must be provided with a low water cut-off device. See page 22 for wiring hook-up. The boiler, when used in connection with a refrigeration system, must be installed so that the chilled medium is piped in parallel with the boiler with appropriate valves to prevent the chilled medium from entering the boiler.

The boiler piping system of a hot water heating boiler, that is connected to heating coils located in air handling units where they may be exposed to refrigerated air circulation, must be equipped with flow control valves or other automatic means to prevent gravity circulation of the boiler water during the cooling cycle.

A diaphragm expansion tank should be installed in the return line. A typical 8" -diameter expansion tank can be used on models H-0030, H-0042, and H-0066, and an 11"-diameter expansion tank can be used on models H-0090, H-0135 and H-0180. Consult tank manufacturer for correct sizing.

PIPING DIAGRAMS

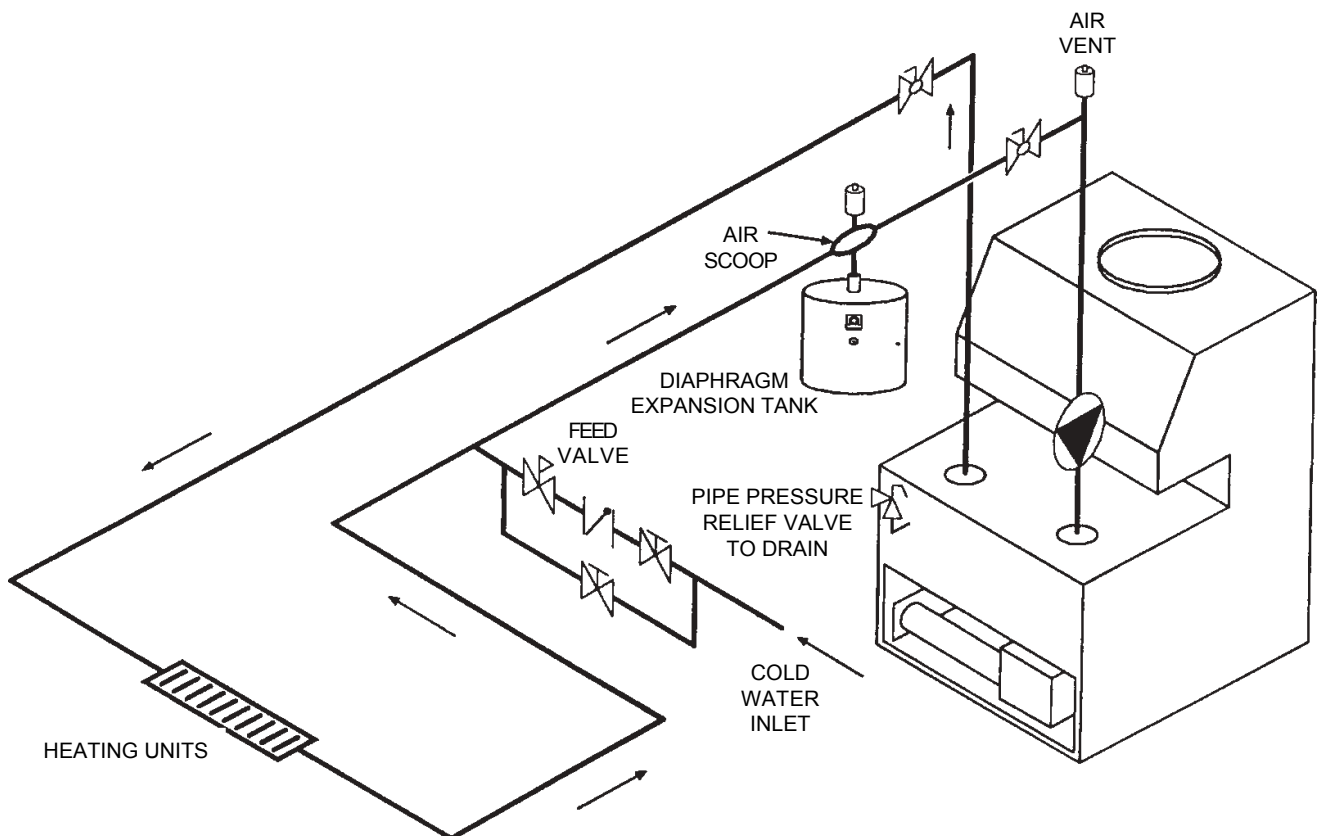

SINGLE-ZONE PIPING

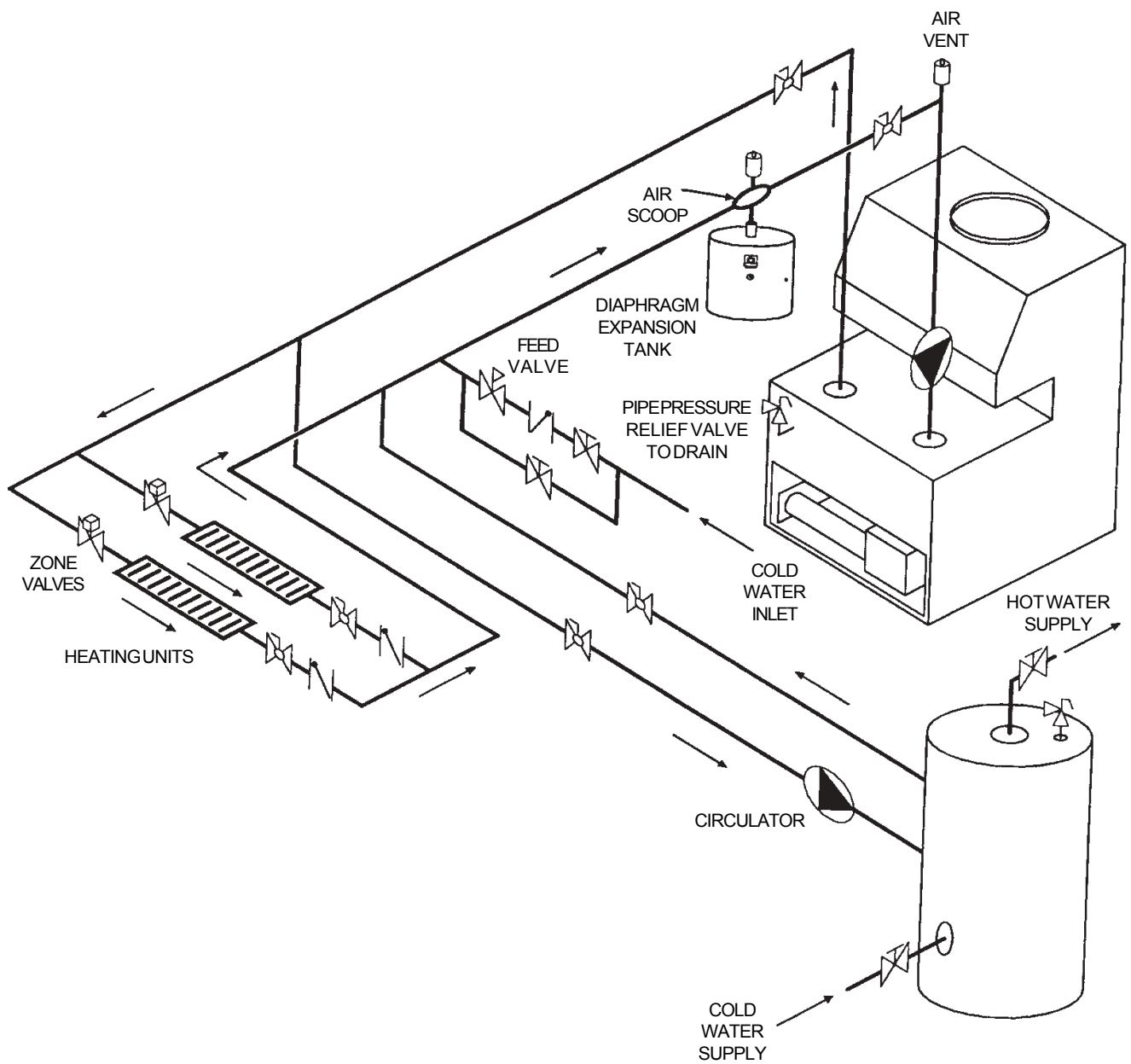

Fig.# 8998.1

ZONE HEATING WITH INDIRECT DOMESTIC
HOT WATER SUPPLY

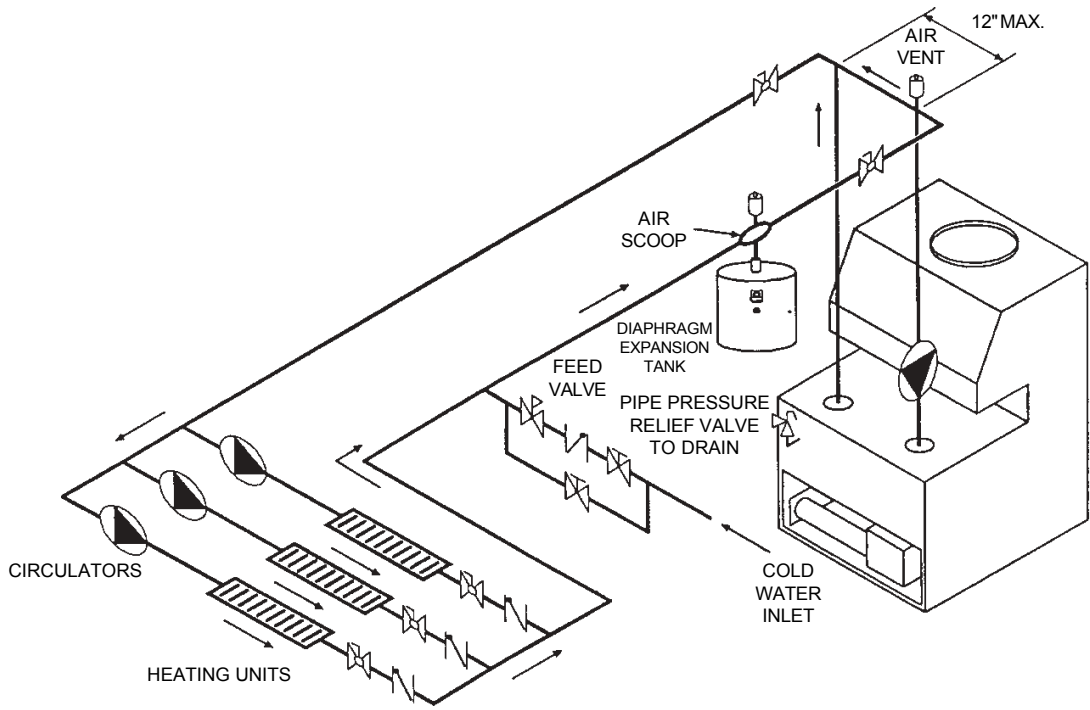

Fig. #8999.1

MULTIPLE ZONES WITH CIRCULATORS

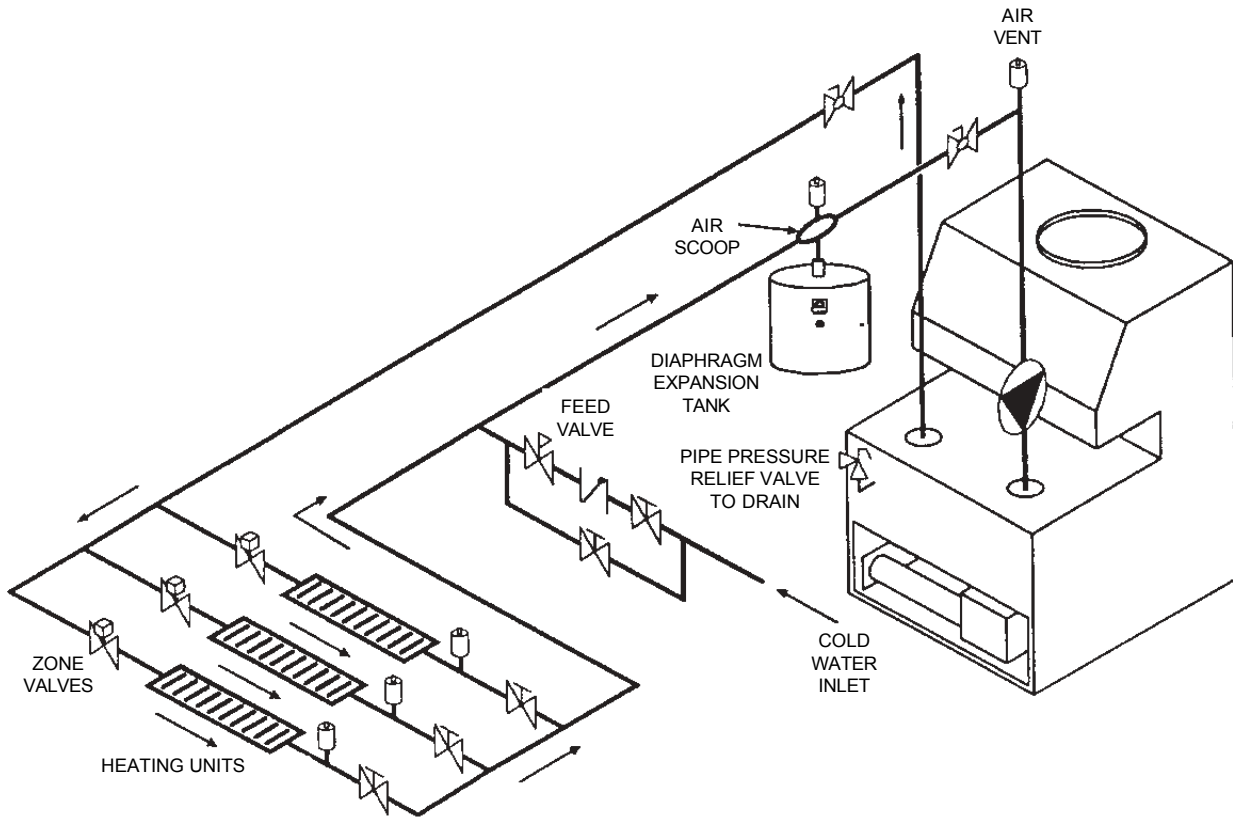

Fig. #9000.1

MULTIPLE ZONES WITH ZONE VALVES

ELECTRICAL WIRING

The electrical power supply requirement for these boilers is 115 volts, 60 Hz. Field wiring connections and electrical grounding must comply with the local codes, or in the absence of local codes, with the National Electrical Code, **ANSI/NFPA 70-1987**. Provide a separate fused circuit from the main electrical panel to the boiler, and a disconnecting means within sight of the boiler.

Remove the control box cover and make the power supply connections in the field wiring compartment. (See general location of controls drawing on page 23). The pump is supplied and factory-wired to operate with the boiler. The "TH" wire leads are for the room thermostat or zone valve connections.

The room thermostat should be installed in accordance with the manufacturer's instructions. The thermostat heat anticipator should be set at 1.0 ampere (automatic ignition) and 0.60 ampere (standing pilot) for single-zone installations. For multi-zone applications, the heat anticipator setting should be based on the ampere load in the thermostat circuit.

NOTE: *If it is necessary to replace any of the original wiring, it must be replaced with 105°C wire or its equivalent, except 150°C black wire must be replaced with 150°C wire or its equivalent. See Wiring Diagram Key for 150°C wire indication.*

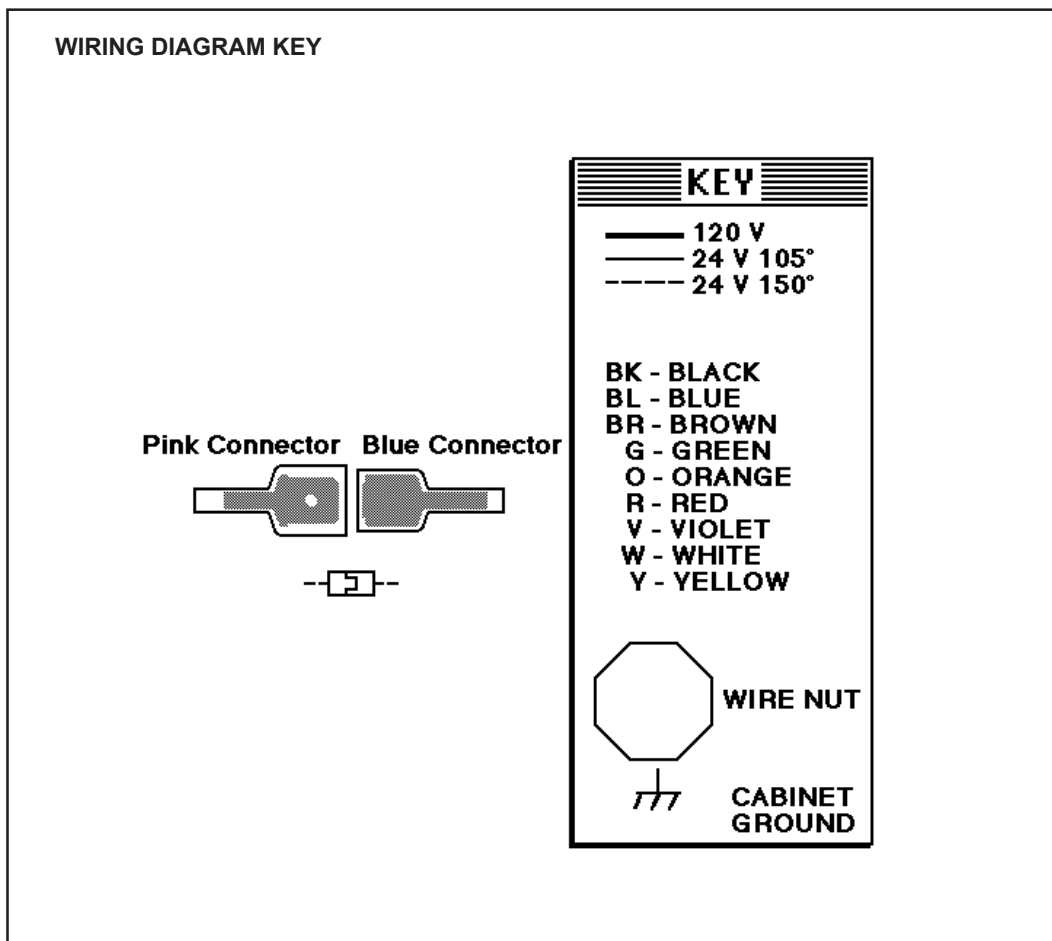
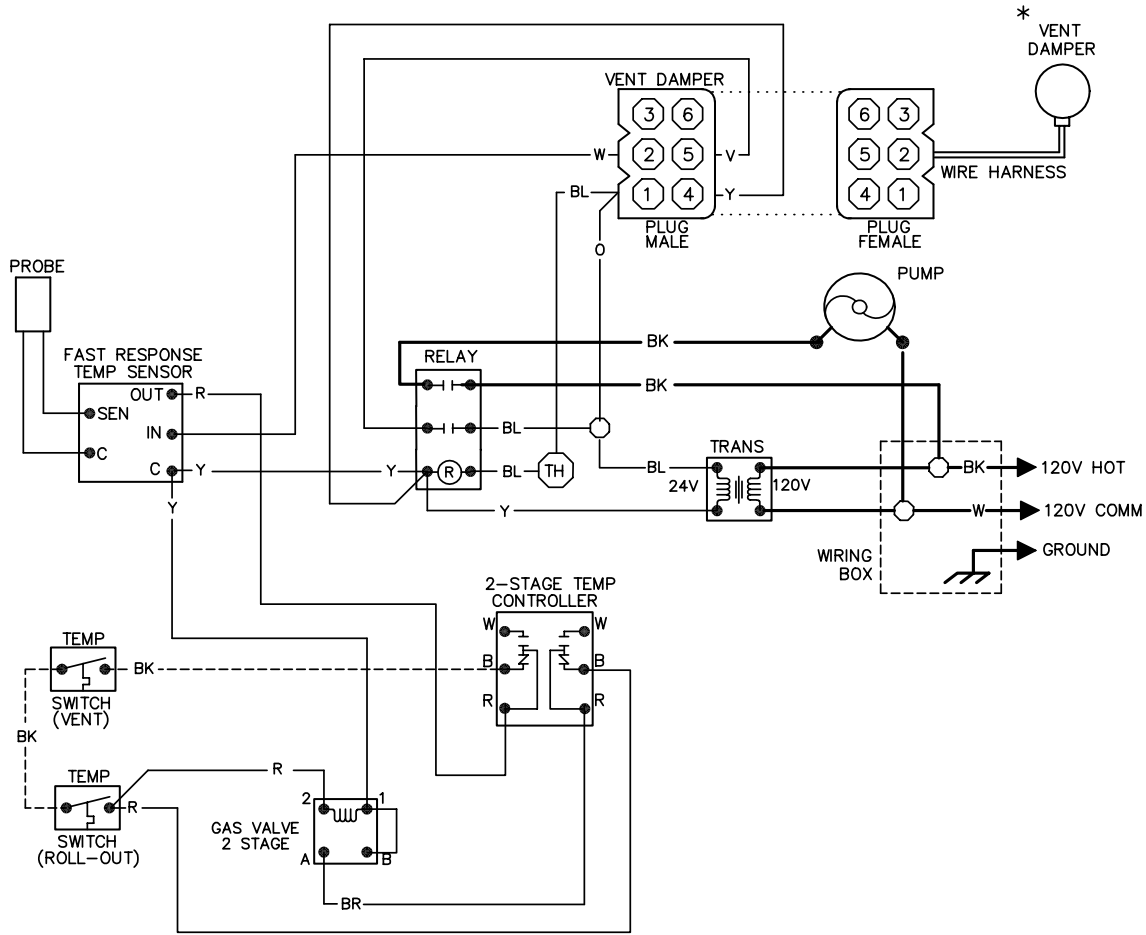

Fig.# 8096.2

WIRING DIAGRAM KEY



* REFER TO INSTALLATION/OPERATION INSTRUCTIONS AND WIRING DIAGRAM SUPPLIED WITH VENT DAMPER.

REPLACE WIRING WITH 105°C WIRE ONLY AND 150°C AS NOTED.

**WIRING DIAGRAM STG FIRE DOE
FIRING MODE-2 STAGE**

BOILER INPUTS: 90,000-180,000 BTUH

BOILER SIZE: 90-180

BOILER TYPE: **H3**

KEY	
———	24V
———	120V
-----	150°C
-----	120V FIELD WIRE
○	WIRE NUT
BK	- BLACK
BR	- BROWN
BL	- BLUE
R	- RED
O	- ORANGE
Y	- YELLOW
G	- GREEN
V	- VIOLET
W	- WHITE
	CABINET GROUND
	TERMOSTAT
152223	6



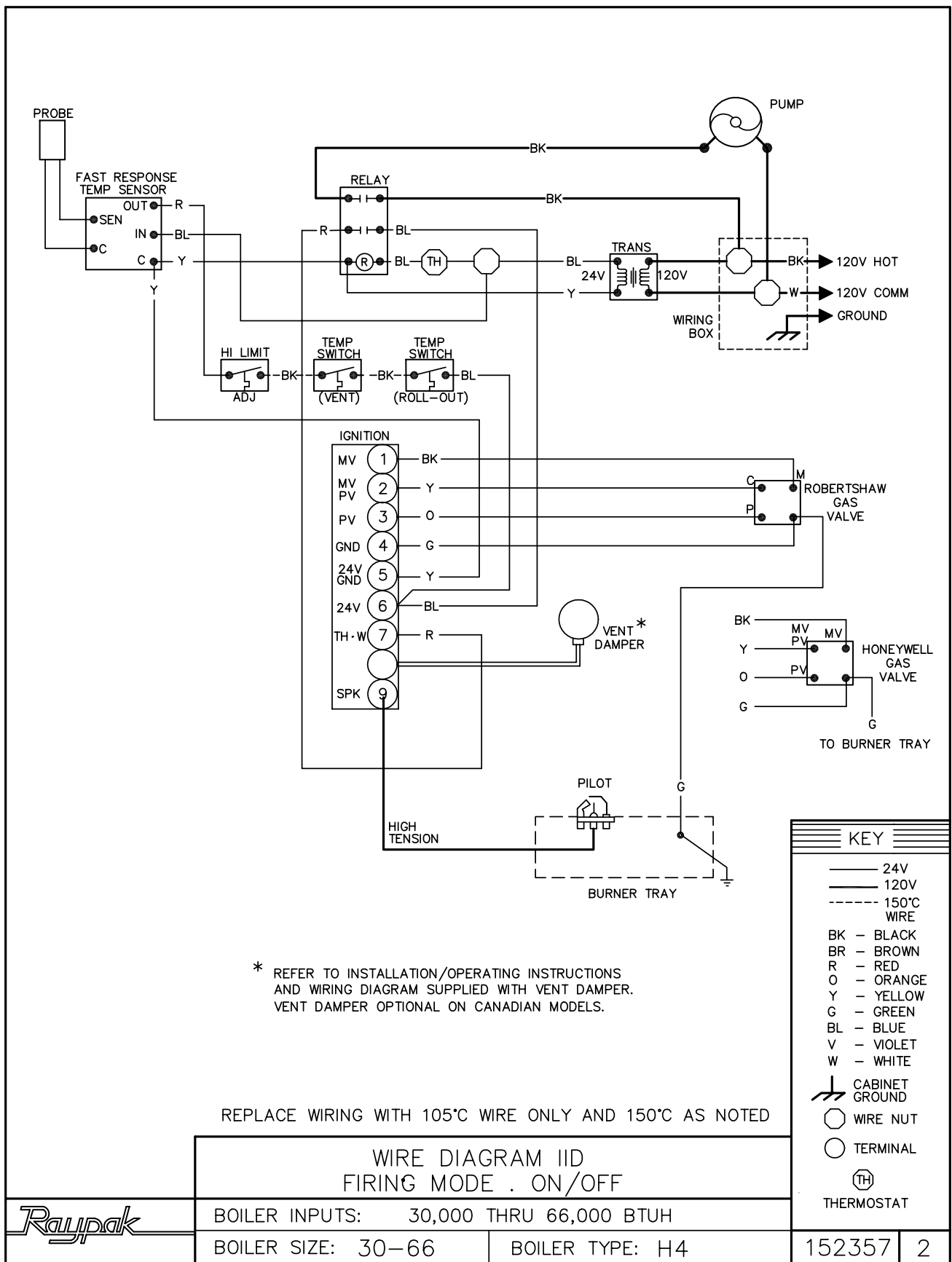

* REFER TO INSTALLATION/OPERATING INSTRUCTIONS AND WIRING DIAGRAM SUPPLIED WITH VENT DAMPER. VENT DAMPER OPTIONAL ON CANADIAN MODELS.

- KEY**
- 24V
 - 120V
 - - - 150°C WIRE
 - BK - BLACK
 - BR - BROWN
 - R - RED
 - O - ORANGE
 - Y - YELLOW
 - G - GREEN
 - BL - BLUE
 - V - VIOLET
 - W - WHITE
 - CABINET GROUND
 - WIRE NUT
 - TERMINAL
 - THERMOSTAT

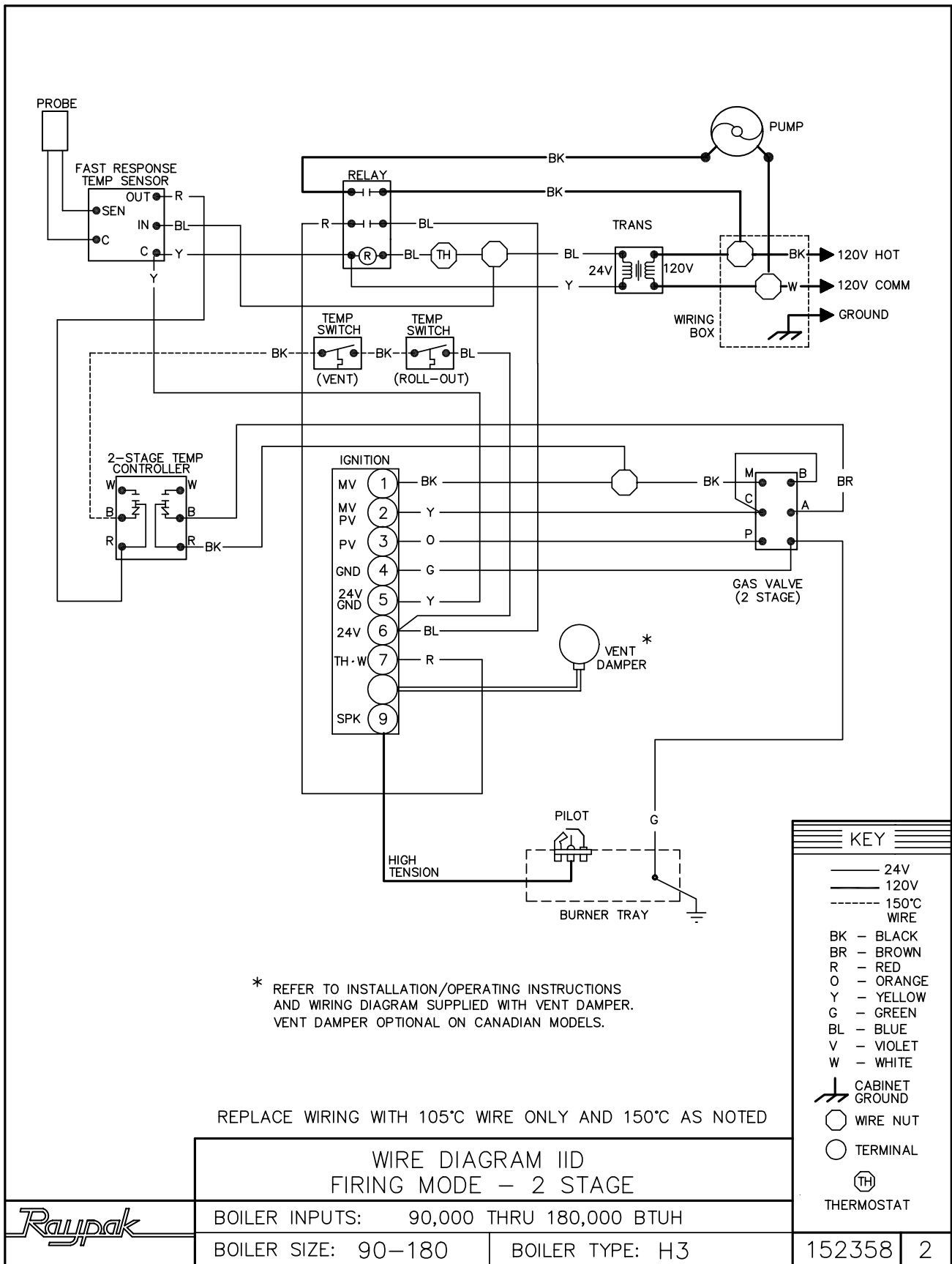

WIRING DIAGRAM: Single-Zone Taco Valve

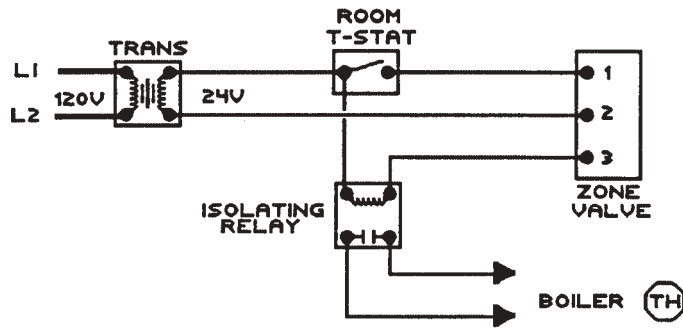

Fig. # 2228e

WIRING DIAGRAM: Dual-Zone Taco Valve

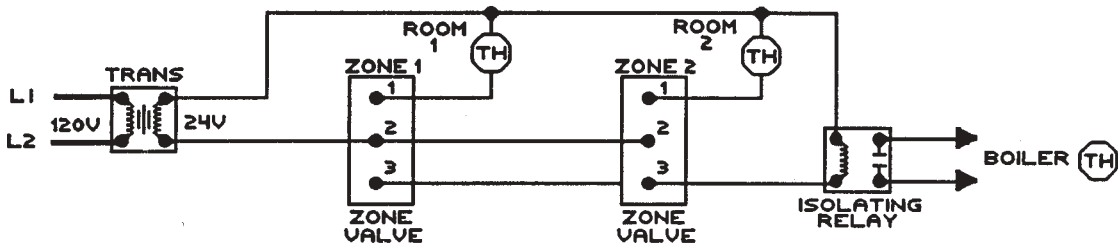

Fig. # 2229e

NOTE: Maximum three (3) zone valves per one (1) 40 VA transformer.

WIRING DIAGRAM: Dual-Zone Honeywell Valve

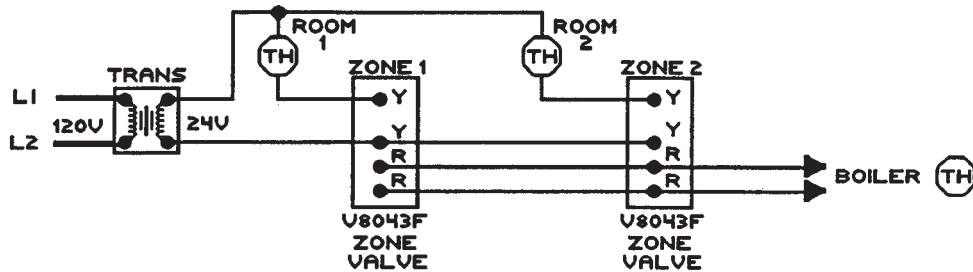

Fig. # 2230e

NOTE: Maximum five (5) zone valves per one (1) 40 VA Transformer.

WIRING DIAGRAM: System with (3) Zone Pumps

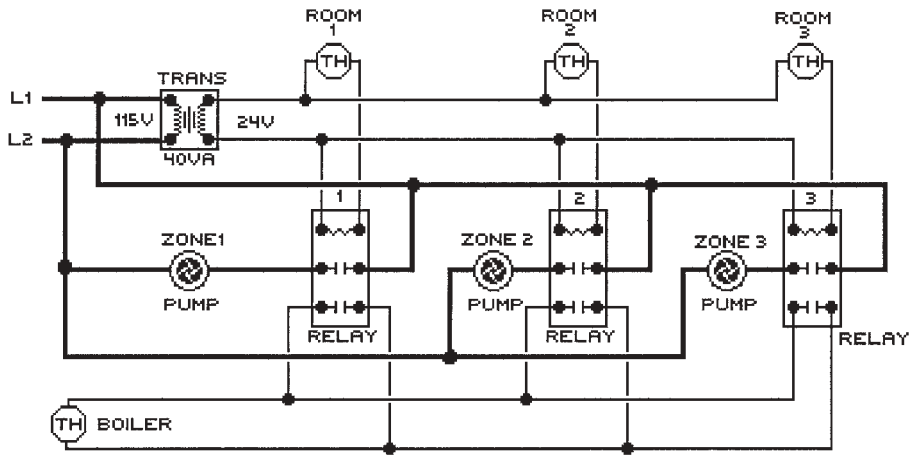

Fig. #2232e

NOTE: Check VA rating of each relay coil. Total load must not exceed VA rating of transformer.

WIRING DIAGRAM: Power Vent System w/ Zone Valve

Taco Zone Valve

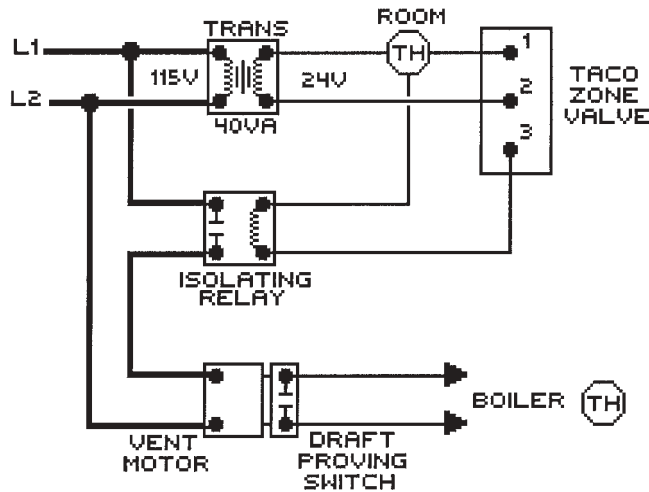

Fig. #2233e

Honeywell Zone Valve

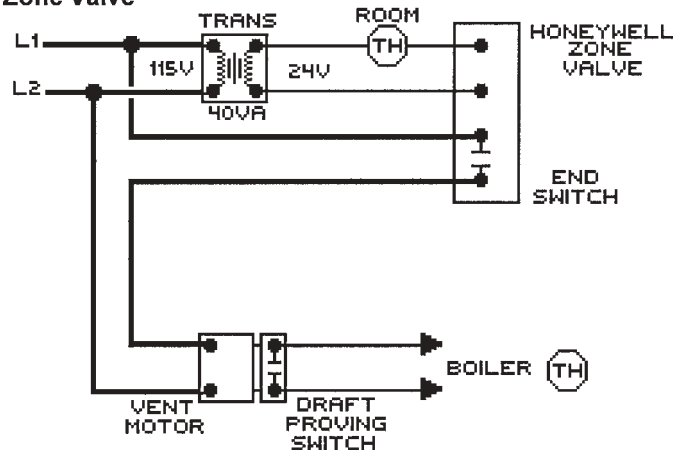

Fig. #2234e

**WIRING DIAGRAM: Primary/Secondary Pumping System
Honeywell Zone Valve**

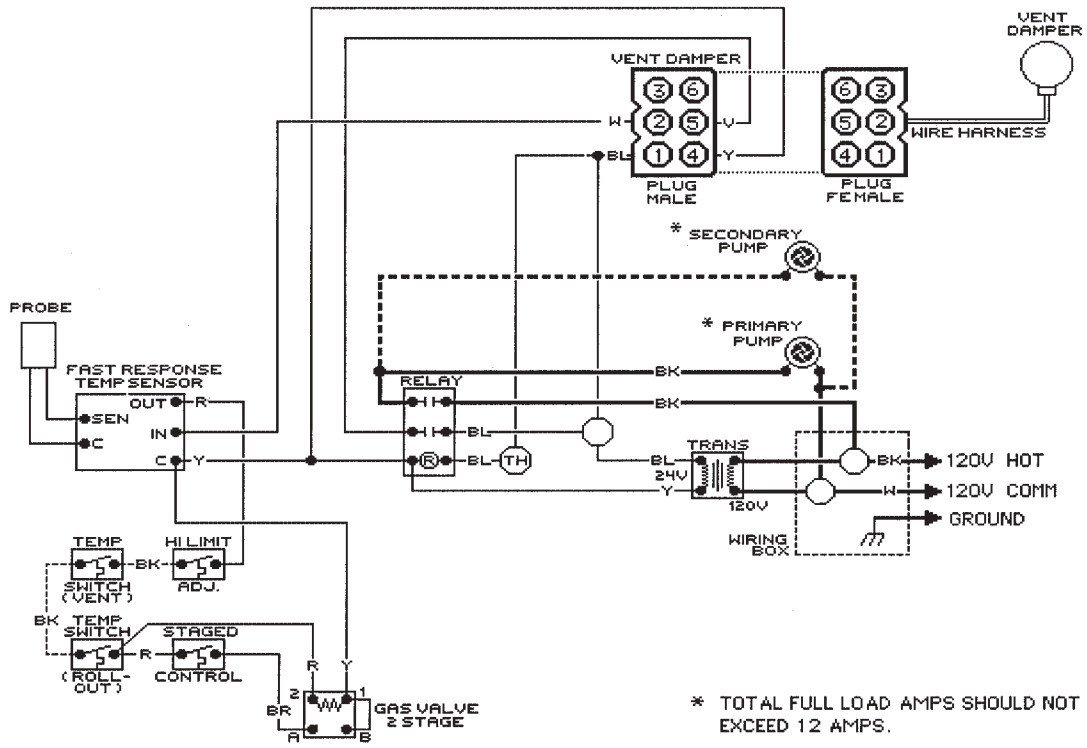

Fig. #2223.2e

WIRING DIAGRAM: Standing Pilot With Low Water Cut-off Device

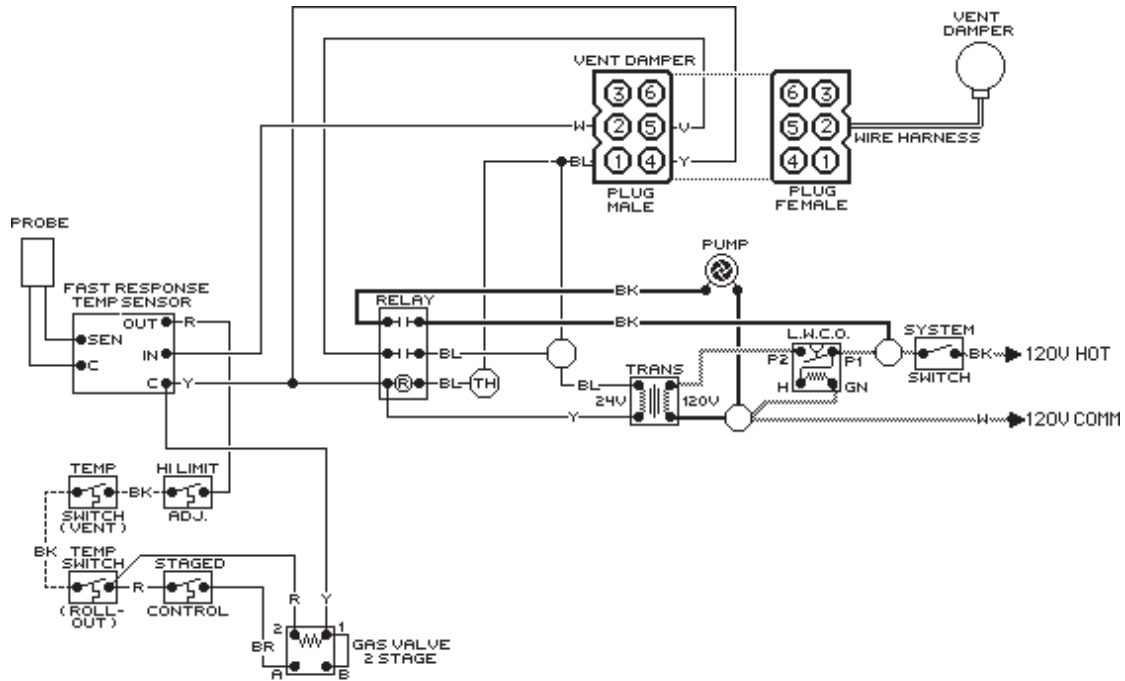

Fig. # 2223.1e

Note: Low water cut-off (LWCO) and system switch supplied by others.

WIRING DIAGRAM: IID Units With Low Water Cut-off Device

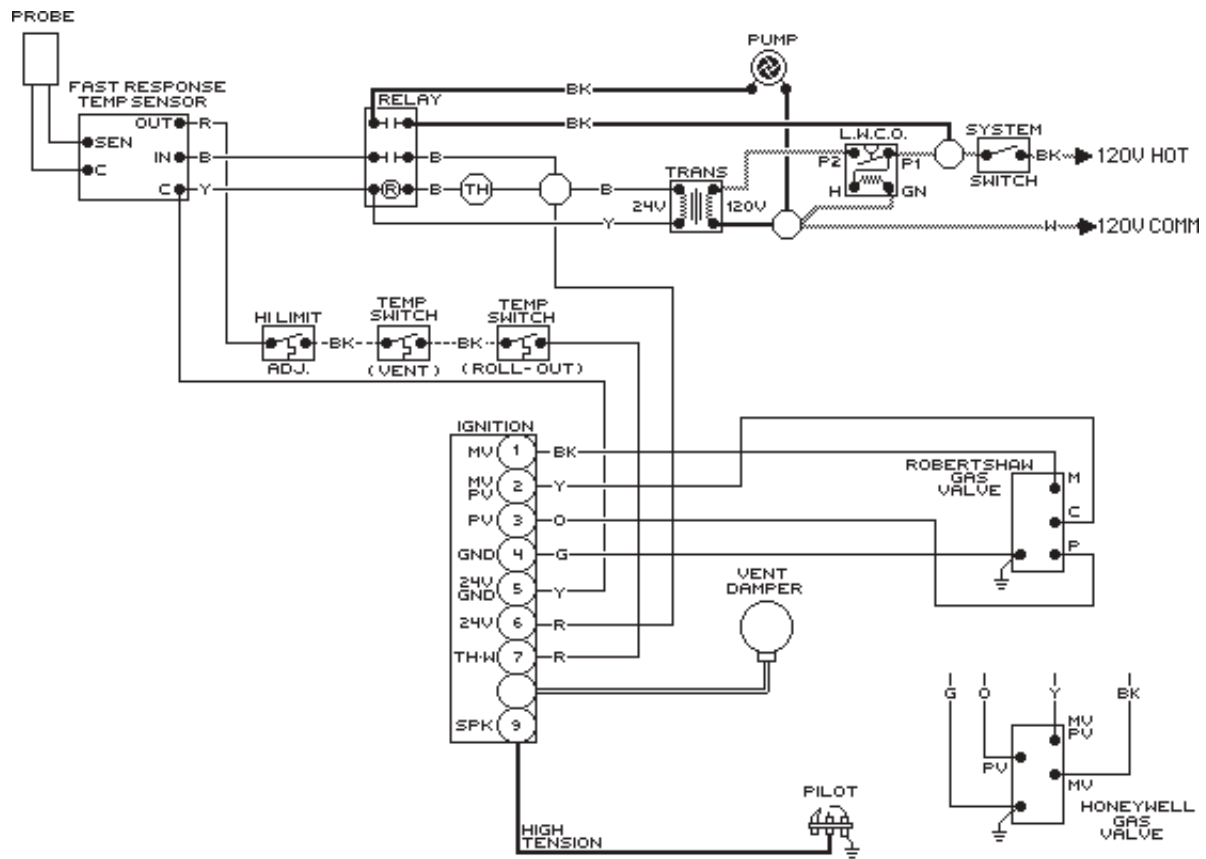

Fig. # 2357E

Note: Low water cut-off (LWCO) and system switch supplied by others.

4. SERVICING PROCEDURES

GENERAL LOCATION OF CONTROLS

CONTROL BOX COMPONENT LOCATIONS MODELS 135 & 180

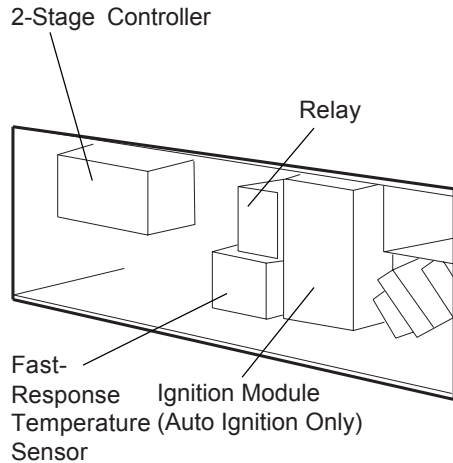

Fig.#8195.1

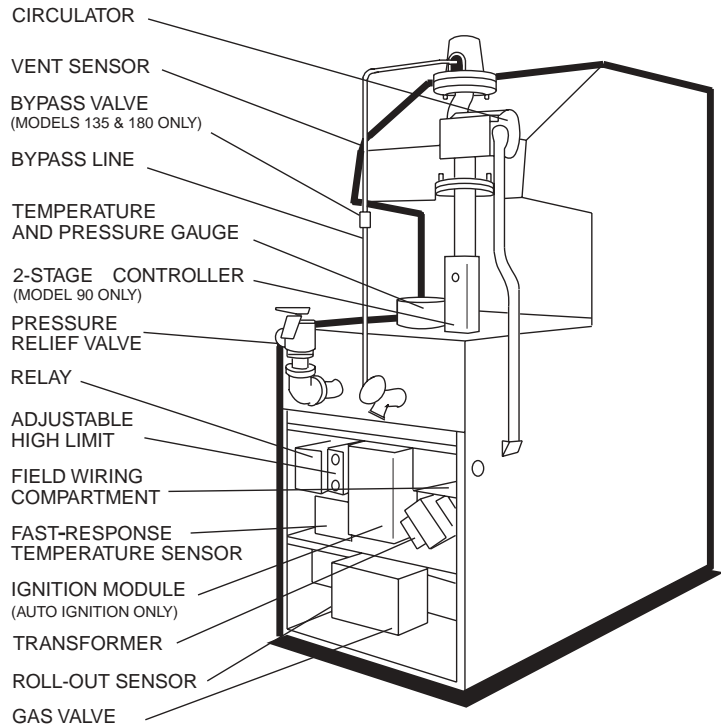

Fig.#8195.4

SEQUENCE OF OPERATION

INTERMITTENT IGNITION DEVICE (IID)

Boilers equipped with the IID system will automatically light the pilot burner first and then the main burner, each time there is a call for heat from the room thermostat. Whenever the room thermostat is calling for heat, the circulator supplied with the boiler, will be energized and should be running. The ignition control module will also be energized to initiate the pilot ignition by opening the first main valve (pilot). At the same time, the electronic spark generator in the module produces a high-voltage spark pulse output that lights the pilot burner. If the pilot burner does not light, the module will not energize the second main valve and the burners will not light. Ignition spark continues only until the timed trial for ignition period ends. Then, the module goes into safety shutdown or lockout. Lockout de-energizes the first main valve operator and closes the first main (pilot) valve in the gas control, stopping pilot gas flow. The ignition control system must be reset by setting the thermostat below room temperature for one minute or by turning off power to the module for one minute. When the pilot flame is established, flame rectification circuit is completed between the sensor and burner ground. The flame sensing circuit in the module detects the flame current, shuts off the spark generator and energizes the second main valve operator which opens the second main valve. This allows gas to flow to the burners where it is ignited by the pilot burner flame. When the thermostat is satisfied, the valve operators are de-energized shutting off the pilot and main burners, and also the circulator.

START-UP PROCEDURES

Lighting the Boiler

Safe-lighting and other performance criteria were met with the gas manifold and control assembly provided on the boiler when the boiler underwent tests specified in ANSI-Z21.13a 1983 Standard.

CAUTION: *Propane gas is heavier than air and sinks to the ground. Exercise extreme care in lighting boiler in confined areas.*

For Standing Pilot Models

WARNING: *If you do not follow these instructions exactly, a fire or explosion may result causing property damage, personal injury or loss of life.*

A. This boiler has a pilot which must be lighted by hand. When lighting the pilot, follow these instructions exactly.

B. **BEFORE LIGHTING** Smell all around the boiler area for gas. Be sure to smell next to the floor because some gas is heavier than air and will settle on the floor.

WHAT TO DO IF YOU SMELL GAS

- Do not try to light any appliance.
- Do not touch any electric switch;
- Do not use any phone in your building.
- Immediately call your gas supplier from a neighbor's phone. Follow the gas supplier's instructions.
- If you cannot reach your gas supplier, call the fire department.

C. Use only your hand to push in, move or turn the gas control knob or lever. Never use tools. If the knob or lever will not push in, move or turn by hand, don't try to repair it, call a qualified service technician. Force or attempted repair may result in a fire or explosion.

D. Do not use this boiler if any part has been under water. Immediately call a qualified service technician to inspect the boiler and to replace any part of the control system and any gas control which has been under water.

Filling the System

Fill system with water. Purge all air from the system using purge valve sequence. After system is purged of air, lower system pressure. Open valves for normal system operation, fill system through feed pressure regulator to minimum 12 PSI. Manually open air vent on the compression tank until water appears, then close vent.

On multiple-zone systems, purge each zone separately. Isolate the other zones while one zone is being purged of air.

Flush system before putting into operation to ensure that foreign material does not damage pump seals.

Checking the Circulator

Before lighting the boiler and after system is filled, make sure that circulator is operating properly. Manual gas valve should be off. By adjusting the wall thermostat to the maximum setting, circulator should run immediately and allow water to flow through the boiler and the entire system.

NOTE: *Circulator motor supplied with the boiler does not require lubrication.*

CAUTION: In case of a prolonged power failure during freezing weather conditions, boiler and piping system must be drained completely to avoid possible damage to the heating system.

FOR STANDING PILOT MODELS WITH ROBERT-SHAW GAS VALVE, 2-STAGE OPERATION (Models 90, 135 & 180)

1. STOP! Read the safety information.
2. Set the thermostat to the lowest setting.
3. Turn off all electrical power to the boiler.
4. Push in and move gas control lever counter-clockwise  to "OFF" position.

GAS CONTROL LEVER SHOWN IN "OFF" POSITION

GAS INLET

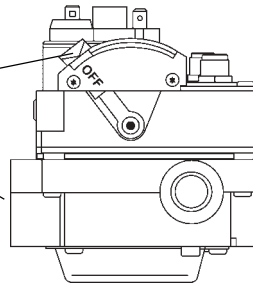

Fig. #8934.0

NOTE: Lever cannot be moved from "ON" to "OFF" unless lever is pushed in slightly. Do not force.

5. Wait five (5) minutes to clear out any gas. Then smell for gas, including near the floor. If you smell gas, STOP! Follow "B" in the safety information above on this label. If you don't smell gas, go to the next step.
6. Locate pilot mounted on the right side of the burner tray, and right of first burner.

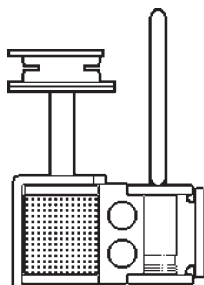

Fig.# 8083.2

HONEYWELL PILOT

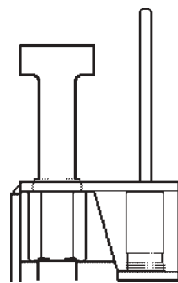





Fig.# 8041.2

ROBERTSHAW PILOT

7. Move control lever clockwise  to "SET" position and immediately light pilot with a match.
8. Hold lever in "SET" position for 1/2 minute after pilot is lit. Release lever, and it will spring back to "PILOT" position. Pilot should remain lit. If it goes out, repeat steps 4 through 8.
*If lever does not spring back to "PILOT" position when released, stop and immediately call your service technician or gas supplier.
*If the pilot does not stay lit after several tries, move the gas control lever to "OFF" and call your service technician or gas supplier.
9. Stand to the side of the boiler and move the gas control lever counter-clockwise  to "ON".

10. Turn on all electrical power to the boiler.
11. Set the thermostat to the desired setting.

TO TURN OFF GAS TO THE BOILER: (Models 90, 135 & 180)

1. Set the thermostat to the lowest setting.
2. Turn off all electrical power to the boiler
3. Push in and move gas control lever counter-clockwise  to "OFF" position. Do not force.

FOR AUTOMATIC IGNITION MODELS.

Please read carefully and understand the following safety information before operating the boiler.

WARNING: *If you do not follow these instructions exactly, a fire or explosion may result causing property damage, personal injury or loss of life.*

A. This boiler is equipped with an ignition device which automatically lights the pilot. Do not try to light the pilot by hand; or this boiler may not have a pilot and is equipped with a hot surface ignition device which automatically lights the burners. Do not try to light the burners by hand.

B. **BEFORE OPERATING** smell all around the boiler area for gas. Be sure to smell next to the floor because some gases are heavier than air and will settle on the floor.

WHAT TO DO IF YOU SMELL GAS

- Do not try to light any appliance.
- Do not touch any electrical switch.
- Do not use any phone in your building.
- Immediately call your gas supplier from a neighbor's phone. Follow the gas supplier's instructions.
- If you cannot reach your gas supplier, call the fire department.

C. Use only your hand to push in, move or turn the gas control knob or lever. Never use tools. If the knob or lever will not push in, move or turn by hand don't try to repair it, call a qualified service technician. Force or attempted repair may result in a fire or explosion.

D. Do not use this boiler if any part has been under water. Immediately call a qualified service technician to inspect the boiler and to replace any part of the control system and any gas control which has been underwater.

FOR INTERMITTENT IGNITION (IID) WITH HONEYWELL OR ROBERTSHAW GAS VALVE (All Models)

1. **STOP!** Read the safety information above.
2. Set the thermostat to the lowest setting.
3. Turn off all electrical power to the appliance.
4. This boiler is equipped with an ignition device which automatically lights the pilot. Do not try to light the pilot by hand.

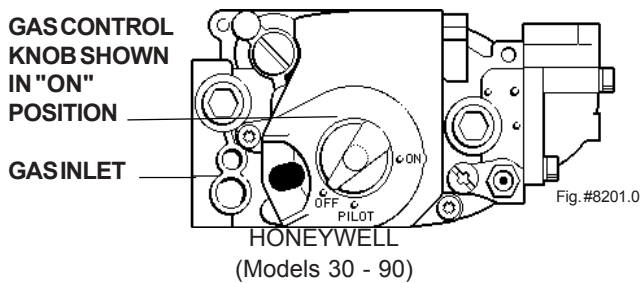

5. **For Honeywell valve:** Turn gas control knob clockwise to "Off".
For Robertshaw valve: Push in and move gas control lever to "Off" position.
6. Wait 5 minutes to clear out any gas. Then smell for gas, including near the floor. If you smell gas, STOP! Follow "B" in the safety information above on this label. If you don't smell gas, go to the next step.
7. **For Honeywell valve:** turn gas control counter-clockwise to "On".
For Robertshaw valve: Move gas control lever to "On" position.

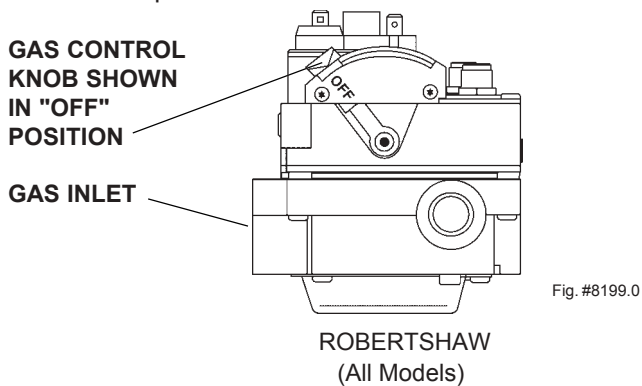

8. Turn on all electrical power to the boiler.
9. Set thermostat to desired setting.
10. If the boiler will not operate, follow the instructions "To Turn Off Gas To Boiler" and call your service technician or gas supplier.

TO TURN OFF GAS TO BOILER

1. Set the thermostat at the lowest setting.
2. Turn off all electrical power to the boiler if service is to be performed.
3. **For Honeywell valve:** Turn gas control knob clockwise to "Off". Make sure knob rest against stop.
For Robertshaw valve: Push in and move gas control lever to "Off" position.

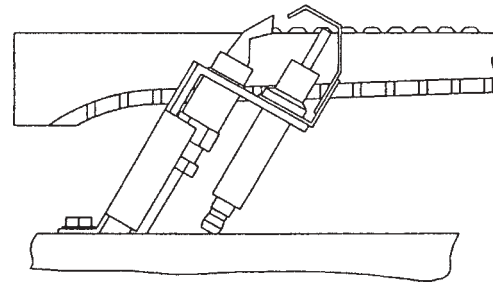

SHUT-DOWN PROCEDURE

To prevent freeze damage to the heating system, it is recommended that the following system shut-down procedure be performed.

1. Set the room thermostat to "OFF" or the lowest setting.
2. Turn off all electrical switches to the boiler.
3. Turn off all gas valves supplying gas to the boiler. Refer to operating instruction label on the boiler.
4. Shut-off the water supply to the boiler piping system loop.
5. Open drain valve on the boiler to remove water from the boiler and the piping circuits.

Note: It may be necessary to open the purge valves and/or manual air vents to facilitate complete drainage of water from the heating system.

CAUTION: Should overheating occur or the gas supply fails to shut-off, **DO NOT** turn off or disconnect the electrical supply to the pump. Instead, shut-off the gas supply at a location external to the boiler. Failure to observe this precaution may aggravate the overheated condition resulting in possible damage to the boiler and injury to the user.



SECTION 4. Testing the Ignition Safety Shut-off.

The ignition system safety shut-off must be tested by conducting the following tests:

For Standing Pilot Systems

- a. With the main burners on, remove the pilot adjustment cover screw.

* **NOTE:** There is no pilot adjustment cover on Robertshaw 7200 gas valve.

- b. Insert a small slot screw driver and turn the adjustment screw clockwise  until pilot flame goes out. Note and count number of turns made.
- c. Gas valve will shut-off main burners after about three (3) minutes. If the gas valve will not shut-off, follow the instructions "To Turn Off Gas To Boiler" and call service technician or your gas supplier.
- d. Return pilot adjustment screw counter-clockwise , using the same number of turns as in step (b).

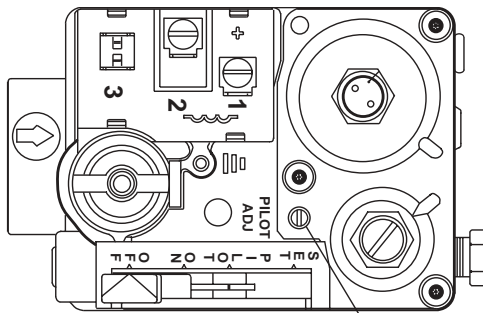

Pilot Adjustment

Fig.# 8935.0

ROBERTSHAW 7200 GAS VALVE (Models 90, 135 & 180)

- e. Replace pilot adjustment cover screw, then follow the lighting instructions to get boiler ready for operation.

FOR AUTOMATIC IGNITION SYSTEMS

Intermittent Ignition (IID)

1. Turn on power to the ignition systems and turn gas supply off at the gas valve.
2. Check ignition module as follows:
 - a. Set the thermostat or controller above room temperature to call for heat.
 - b. Watch for continuous spark at the pilot burner.
 - c. Time the spark operation. Time must be within the lockout timing period (15 or 90 seconds).
 - d. Turn thermostat down to end call for heat and wait 60 seconds on lockout models before beginning step 3.
3. Turn on gas supply.
4. Set thermostat or controller above room temperature to call for heat.
5. Systems should start as follows:
 - a. Spark will turn on and pilot gas valve will open at once. Pilot burner should ignite after gas reaches the pilot burner.
 - b. Spark ignition should cut-off when pilot flame is established.
 - c. Main gas valve should open and main burner should ignite after gas reaches the burner port.

SAFE SHUT-DOWN TESTS

LIMIT ACTION

With the burner operating, lower the high limit setting to simulate an overheated boiler. Normal shut-down should occur. Restore the normal limit setting, and the burner should restart.

FLAME FAILURE

With burner operating, close the manual fuel valves to simulate a flame failure. System should lock out after safety switch timing (15 seconds). After the safety switch has cooled, open the manual valves (relight standing pilots) and reset the safety switch; the burner should restart.

INSPECTION PROCEDURES

BURNERS

Clean main burners and air louvers of dust, lint and debris. Keep boiler area clear and free from combustibles and flammable liquids. Do not obstruct the flow of combustion and ventilation air. Make visual check of burner and pilot flame. Yellow flame indicates clogging of air openings. Lifting or blowing flame indicates high gas pressure. Low flame indicates low gas pressure.

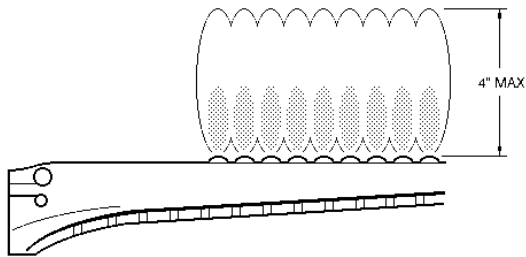

Fig. #8144

MAIN BURNER FLAME

NOTE: Modulating burner flame varies in height from approximately 1/4" at low fire to approximately 4" in high fire.

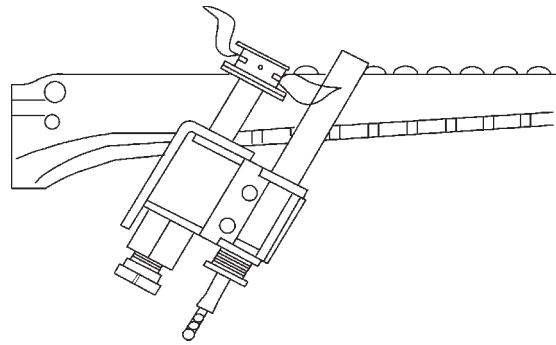

Fig. #8964

PILOT BURNER FLAME (STANDING PILOT UNITS)

INSPECTION PROCEDURES

To be performed the first and third month after initial start up and then on an annual basis. If problems are found, refer to Troubleshooting Guide for additional directions.

1. Remove top of boiler and inspect heat exchanger for soot and examine venting system.
 2. Remove rear header and inspect for scale deposits.
 - *3. Inspect pilot and main burner flame and firing rate.
 - *4. Inspect and operate all controls and gas valve.
 - *5. Visually inspect system for water leaks.
 - *6. Inspect oil pump motor and bearing assembly, if oil cups are provided.
 7. Check flow switch paddle.
 8. Clean room air intake openings to ensure adequate flow of combustion and ventilation air.
 9. Keep boiler area clear and free from combustible materials, gasoline, and other flammable vapors and liquids.
- *Should be checked monthly. (Takes approximately 15 minutes).

LOW WATER CUT-OFF WHEN INSTALLED

The low water cut-off automatically shuts down burner whenever water level drops below probe. 90 second time delay prevents premature lockout due to temporary conditions such as power failure or air pockets. Flush float type devices at beginning of each heating season.

PROCEDURE FOR CLEANING FLUE GAS PASSAGE-WAYS

Soot will clog areas behind fins and eventually cause tube failure. Any sign of soot at base of burners or around outer jacket indicates a need for cleaning.

1. Lift off drafthood and flue collector by removing bolts and screws.
2. Remove "V" baffles from heat exchanger.
3. Remove burner tray, see Burner Tray Removal.
4. Take garden hose and wash heat exchanger, making sure soot is removed from between fins. (Avoid excessive water against refractory).
5. Reassemble; when boiler is fired, some steam will form from wet refractory. This is normal.

NOTE: In extreme cases it may be necessary to remove the heat exchanger completely for cleaning. The simplest method is steam cleaning at a local car wash. **DO NOT WIRE BRUSH!**

CAUTION:

Soot is combustible, so exercise extreme care.

BURNER TRAY REMOVAL

1. Shut-off power and gas supply to the boiler. Disconnect union(s) and pilot tubing when present; then loosen and remove burner hold-down screws.
2. Disconnect wires at gas valve and slide burner drawer out.

MAIN BURNER AND ORIFICE REMOVAL

1. Remove screws and burner hold-down bracket.

NOTE: If the heat exchanger is sooted badly, the burner hold-down bracket and spacer can become distorted from direct flame impingement and this usually necessitates replacement of these parts.

2. Lift burners from slotted spacer and slide from orifices. Clean with a wire brush.
3. Orifices usually do not need to be replaced. To clean, run either copper wire or wood through orifice. Do not enlarge hole. To remove orifice, use a socket wrench and remove the manifold. **DO NOT** overtighten when reinstalling.

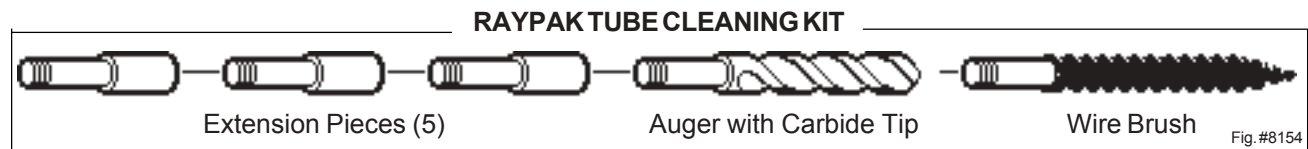

REPAIR PROCEDURES

TUBE CLEANING PROCEDURE (TYPICAL)

Establish a regular inspection schedule, the frequency of which depends on the local water condition and severity of service. Do not let the tubes clog up solidly. Clean out deposits over 1/16" in thickness.

The boiler may be cleaned from the side opposite the water connections as shown, without breaking pipe connections. It is preferable, however, to remove both headers for better visibility through the tubes and to be sure the residue does not get into the system.

Note that you do not typically remove the top pan or the heat exchanger.

After reaming with the auger, mount the wire brush and clean out the debris remaining in the tubes.

Another method is to remove the heat exchanger, ream tubes and immerse heat exchanger in non-inhibited de-scale solvent.

HEAT EXCHANGER REMOVAL

1. Shut water, gas and electricity off, close valves, relieve pressure and remove relief valve. Remove side inspection panels.
2. Remove top holding screws.
3. Remove draft diverter, lift and remove top and flue collector on stack type models. Remove inspection panels.
4. Loosen bolts and disconnect flange nuts on inlet-outlet header, loosen union(s) at gas pipe, and slide boiler away from piping until studs clear the heater.
5. Remove heat exchanger corner brackets.

- Remove combustion chamber clips at the four corners of the heat exchanger.
- Lift heat exchanger straight up using caution not to damage refractory.

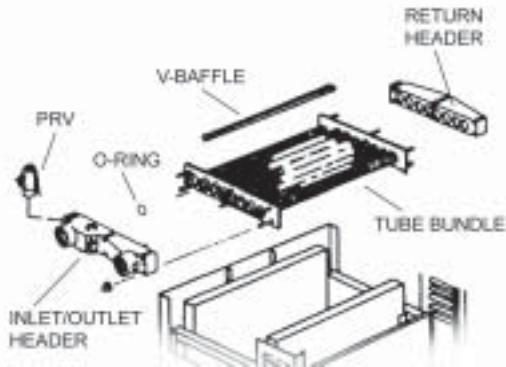

Fig#9337

HEAT EXCHANGER RE-ASSEMBLY

- Heat exchanger water header O-rings should be replaced with new ones.
- Install in/out and return water headers and install header retainer nuts and torque nuts evenly.
- Replace "V" baffles.
- Install thermostat sensing bulbs in header wells and replace bulb retaining clips.
- Install inlet and return pipes in water headers using pipe thread sealant.
- Install water pressure relief valve, flow switch, and low water cut-off devices if so equipped.
- Open water supply and return shut-off valves. Fill boiler and water piping system with water. Check

boiler and piping system for leaks at full line pressure. Run system circulating pump for a minimum of 1/2 hour with boiler shut off.

- Shut down entire system and vent all radiation units and high points in system piping. Check all strainers for debris. Expansion tank water level should be at the 1/4 mark and the balance of the tank filled with air (when using Air-X-Tank).
- Install flue collector, jacket top and inspection panels. Install top holding screws. Install draft diverter and vent piping if so equipped.
- If gas piping was disconnected, reconnect gas piping system and check for leakage using a soap solution.
- Check for correct water pressure and water level in the system. Make sure that system pump operates immediately on the call for heat. The system is ready for operation.
- Within two (2) days of start-up, recheck all air vents and expansion tank levels.

COMBUSTION CHAMBER REMOVAL

To remove combustion chamber you must first have removed the heat exchanger. Unbolt metal combustion chamber retainer from top and remove combustion chamber panels individually.

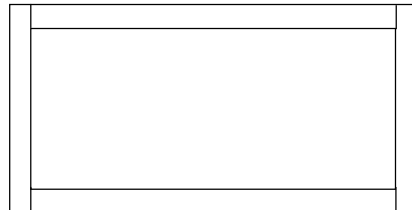

TROUBLESHOOTING GUIDE

IMPORTANT NOTICE

These instructions are primarily intended for the use of qualified personnel specifically trained and experienced in the installation of this type of heating equipment and related system components. Installation and service personnel may be required by some states to be licensed. Persons not qualified shall not attempt to install this equipment nor attempt repairs according to these instructions.

PROBLEM	CAUSES	SOLUTIONS
1)When room thermostat is turned on, boiler does not operate.	1)No power to the boiler. 2)Defective room thermostat or disconnected wire in thermostat circuit. 3)Defective transformer. 4)Defective pump relay. 5)Defective pump.	1)Check circuit breakers, disconnect switch. Make sure power is on. 2)Check continuity on thermostat and wiring circuit. Replace thermostat, or repair wiring connections. 3) Check secondary voltage. If no 24V, replace transformer. 4) Check relay coil or contacts. Replace as required. 5) Replace pump.
2)When room thermostat is calling for heat, pump is on, but burners will not turn on.	1)For standing pilot models pilot, burner not lighted. 2)If pilot burner will not stay lighted, thermocouple or gas valve may be defective. 3)Gas knob in "Pilot" position. 4)For automatic ignition models, gas valve knob is in "off" position. 5)Vent switch is open. 6)Roll-out switch is open. 7)High limit is open. 8) Fast Response Temperature Sensor probe is defective. 9) Fast Response Temperature sensor board is defective.	1)Light pilot burner. (Follow lighting instructions on rating plate.) 2)Check thermocouple MV generation. If less than 25MV (open circuit), replace thermocouple. If between 25-35 MV, replace gas valve. 3)Turn knob to "ON" position. 4)Turn gas knob to "ON". If ignition module locks out, reset by interrupting power to boiler. 5) Check for blockage of venting system or disconnected vent piping. After problem is corrected push button to reset, or replace single-use type vent switch. 6)Check for blockage of flue or sooted heat exchanger. After problem is corrected push button to reset or replace single use type roll-out switch. 7)Setting may be too low. Check water flow and adjust setting to obtain 20-30°F temperature rise. 8)Red LED on circuit board will be <u>ON</u> to indicate a loose sensor connection or a shorted sensor. Check terminal connectors or replace sensor as required. NOTE: Red LED will also be <u>ON</u> if sensor temperature exceeds 300°F or drops below - 20°F. It will turn <u>OFF</u> when sensor temperature returns to the proper range. Yellow LED will be <u>ON</u> if temperature exceeds 240°F. It will turn off when sensor temperature falls below 180°F. When either Red or Yellow LED is ON, boiler will be shut down. 9)Check voltage across output and common terminals. If no 24V is present, replace board.

	10) Defective ignition module or defective gas valve.	10) Before module goes into a lock-out, check voltage across MV and MV/PV. If no 24V is present, replace module. If 24V is present, replace gas valve.
3) Pilot Outage. (Standing pilot models)	1) Too low or too high gas pressures. 2) Restricted pilot. 3) Weak thermocouple.	1) Adjust inlet gas pressure as shown on rating plate. 2) Clean pilot orifice. 3) Replace thermocouple.
4) Yellow lazy flame.	1) Too low gas pressure. 2) Restricted burner intake ports. 3) Restricted gas line.	1) Adjust manifold pressure as shown on rating plate. 2) Clean burners free of debris or insects. 3) Clean gas line or increase gas line piping.
5) Sooting	1) Insufficient combustion air. 2) Improper venting. 3) Severe yellow burner flames.	1) Refer to installation instructions regarding combustion air requirements. 2) Refer to installations instructions. 3) See yellow flame section above.

ADJUSTMENT/REPLACEMENT OF COMPONENTS

DANGER - SHOCK HAZARD

Make sure electrical power to the boiler is disconnected to avoid potential serious injury or damage to components.

1. Gas Valve Replacement
 - a) Shut-off electrical power and gas supply to the boiler.
 - b) Remove gas piping to gas valve inlet.
 - c) Disconnect wiring connections, pilot tubing (when present).
 - d) Remove screws (2) holding the burner tray.
 - e) Slide burner tray out.
 - f) Remove gas valve bracket screws and bracket.
 - g) Unscrew gas valve from gas pipe.
 - h) Reverse above procedure to re-install.

2. Pilot Burner Cleaning or Replacement (Standing Pilot)
 - a) Shut-off electrical power and gas supply to the boiler.
 - b) Disconnect gas piping to gas valve.
 - c) Disconnect wiring connections to gas valve.
 - d) Remove screws (2) holding the burner tray.
 - e) Slide burner tray out.
 - f) Remove screw holding pilot lighter tube.
 - g) Remove screws (2) holding pilot bracket on the burner tray.
 - h) Disconnect thermocouple and pilot tubing from the gas valve.
 - i) Remove pilot burner from pilot bracket.
 - j) Remove pilot orifice and blow away lint or dirt. Clean with wire or small brush.

NOTE: *Make sure pilot orifice is clear, but do not enlarge the hole.*

 - k) Reverse above procedure to re-install.

HONEYWELL PILOT

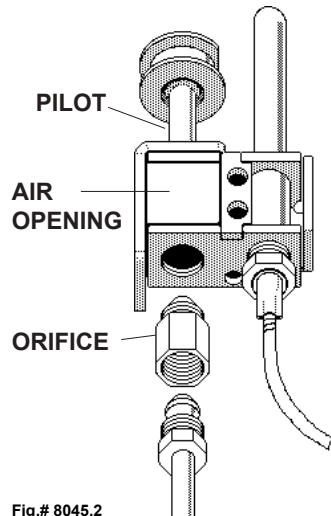

Fig.# 8045.2

ROBERTSHAW PILOT

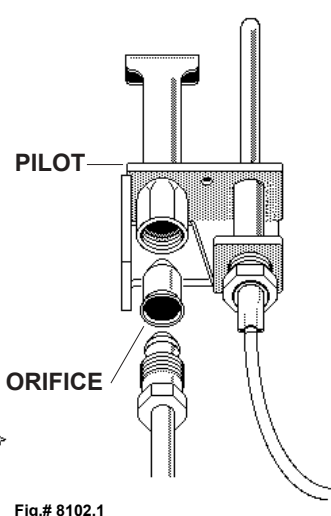

Fig.# 8102.1



3. Flame Roll-out Switch Replacement
 - a) Shut-off electrical power to the boiler.
 - b) Remove wiring connections to switch.
 - c) Remove screws (2) holding the switch.
 - d) Reverse above procedure to re-install.

4. Vent Thermal Switch Replacement
 - a) Shut-off electrical power to the boiler.
 - b) Remove wiring connections to switch.
 - c) Remove the screws (2).
 - d) Reverse above procedure to re-install.

5. Ignition Module Replacement
 - a) Shut-off electrical power to the boiler.
 - b) Remove control cover screws and open control compartment.
 - c) Disconnect wiring connections to module.
 - d) Remove screws (2) holding module.
 - e) Reverse above procedure to re-install.

6. Transformer Replacement
 - a) Shut-off electrical power to the boiler.
 - b) Remove control cover screws and open control compartment.
 - c) Disconnect wiring connections from transformer leads.
 - d) Remove screws (2) holding transformer.
 - e) Reverse above procedure to re-install.

7. Pump Relay Replacement
 - a) Shut-off electrical power to the boiler.
 - b) Remove control cover screws and open control compartment.
 - c) Disconnect wiring to the relay.
 - d) Remove screws (2) holding relay.
 - e) Reverse above procedure to re-install.

8. High Limit Control
 - a) Shut-off electrical power to the boiler.
 - b) Remove control cover screws and open control compartment.
 - c) The control is factory set at 180°F. To adjust to setting, use a small screw driver and turn dial clockwise  to lower the temperature or counter-clockwise  to raise the setting.
 - d) To replace the limit control, disconnect the wiring connections.
 - e) Remove screws (2) holding the limit control.
 - f) Remove upper access panel.
 - g) Remove the wedge or retaining clip holding the sensing bulb in the control well in the in/out header.
 - h) Pull out the sensing bulb carefully from the control well.
 - i) Remove the limit control with capillary from unit.
 - j) Reverse above procedure to re-install.



9. Fast-Response Temperature Sensor Module Replacement
- Shut-off electrical power to the boiler.
 - Remove control cover screws and open control compartment.
 - Disconnect wiring to the board.
 - Carefully pull out the control board from the nylon pin supports.
 - Reverse above procedure to re-install.

10. Fast-Response Temperature Sensor Probe Replacement
- Shut-off electrical power to the boiler.
 - Shut-off water supply to the boiler and open drain valve to remove water to the sensor probe level.
 - Remove control cover screws and open control compartment.
 - Disconnect wire leads from control board.
 - Remove upper access panel.
 - Remove sensor probe from in/out header.
 - Reverse above procedure to re-install.

11. Circulator Replacement
- Shut-off electrical power to the boiler.
 - Shut-off water supply and open drain valve to remove water in the piping at the pump level.

CAUTION: To avoid damage to electrical components keep water from getting into the control compartments and gas valve.

- Disconnect wiring and conduit connections to the pump.
- Disconnect the bypass tube connections to the inlet flange.
- Remove the nuts and bolts at the inlet and outlet flanges. Remove old gaskets.
- Remove the pump.
- Reverse the above procedure to re-install. Use new gaskets and make sure they are seated properly when tightening the nuts and bolts.

12. 2-Stage Controller (Models 90, 135 & 180)
- Shut-off electrical power to the boiler.
 - Remove control cover screws and open control compartment.
 - The control is factory set at 160°F. To adjust to another setting, use a small screw driver and turn dial clockwise  to lower the temperature or counter-clockwise  to raise the setting.
 - To replace the stage controller, disconnect the wiring connections.
 - Remove screws (2) holding the staged controller.
 - Remove upper access panel.
 - Remove the wedge or retaining clip holding the sensing bulb in the control well in the in/out header.
 - Pull out the sensing bulb carefully from the control well.
 - Remove the stage control with capillary from unit.
 - Reverse above procedure to re-install.

6. REPLACEMENT PARTS LIST

NOTE: To supply the correct part it is important that you supply the model number, serial number and type of gas when applicable.

Any part returned for replacement under standard company warranties must be properly tagged with RAYPAK return parts tag, completely filled in with the heater serial number, model number etc., and shipped to Raypak freight prepaid.

If determined defective by Raypak and within warranty, the part will be returned in kind or equal substitution, freight collect. Credit will not be issued.

RAYPAK, INC.
2151 Eastman Avenue
Oxnard, CA 93030

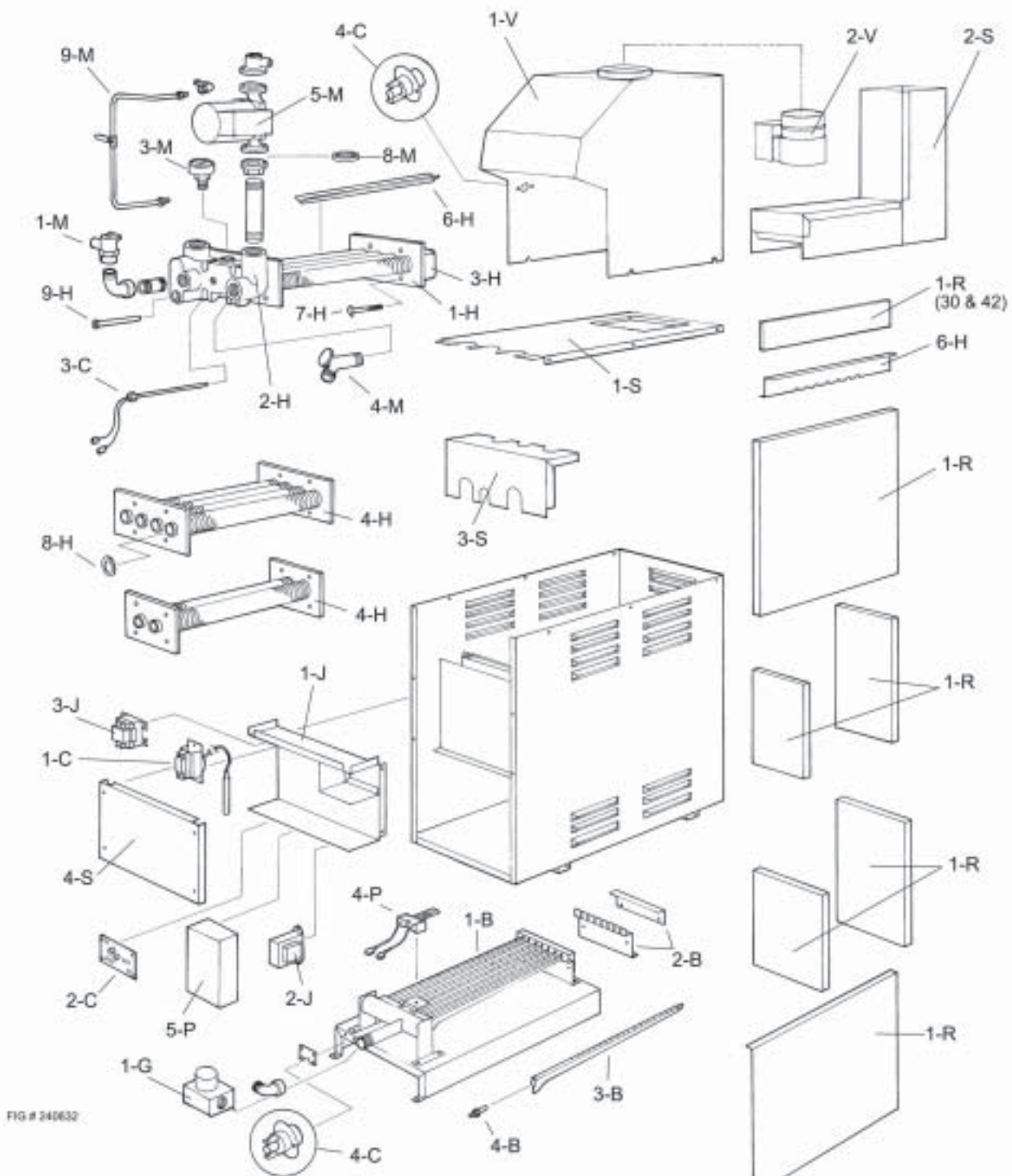

FIG # 240632

HONEYWELL STANDING PILOT

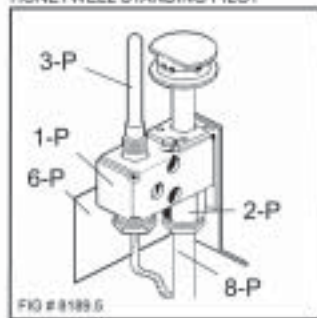

FIG # 8189.5

HONEYWELL IID

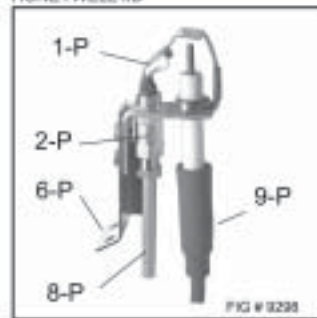

FIG # 8228

ROBERTSHAW STANDING PILOT

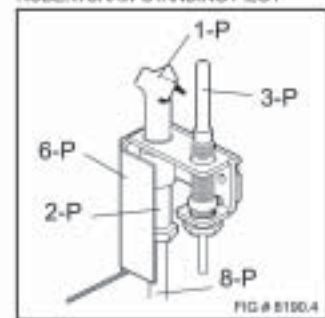

FIG # 8180.4

CALL OUT	DESCRIPTION	30B	42B	66B	90B	135B	180B
B	BURNER TRAY						
1-B	Burner Tray w/o Gas Valve (Sea Level) *	003938F	003939F	004513F	003940F	004227F	004228F
	Burner Tray w/ Gas Valve Nat. STG	004801F	004753F	004761F	004769F	004805F	004793F
	Burner Tray w/ Gas Valve Nat. STG 2 Stage				007051F		
	Burner Tray w/ Gas Valve Pro. STG	004802F	004754F	004762F	004770F	004806F	004794F
	Burner Tray w/ Gas Valve Pro. STG 2 Stage				007052F		
	Burner Tray w/ Gas Valve Nat. HSI	004803F	004755F	004763F	004771F	004807F	004822F
	Burner Tray w/ Gas Valve Pro. HSI	004804F	004756F	004764F	004772F	004808F	004823F
	Burner Tray w/ Gas Valve Nat. IID	005449F	005451F	005453F	005455F	005457F	005459F
	Burner Tray w/ Gas Valve Pro. IID	005450F	005452F	005454F	005456F	005458F	005460F
2-B	Burner Spacer/Holddown	003941F	003941F	003942F	003942F	004229F	004230F
3-B	Burner	301210/3	301210/3	301210/7	301210/7	301210/11	301210/15
4-B	Burner Orifice Nat. (Sea Level) *	350347F/3	350079F/3	350347F/7	350080F/7	350080F/11	350080F/15
	Burner Orifice Pro. (Sea Level) *	350353F/3	350083F/3	350353F/7	350350F/7	350351F/11	350351F/15
C	CONTROLS						
1-C	Adj. Auto High Limit	601003	601003	601003	601003	601003	601003
	Staged Controller				600887	600887	600887
2-C	Electronic Fast Response Sensor w/Probe	003943F	003943F	003943F	003943F	003943F	003943F
3-C	Probe Fast Response	601017	601017	601017	601017	601017	601017
4-C	Roll-Out/Flue Sensor	006021F	006021F	006021F	006021F	006021F	006021F
G	GAS VALVES						
1-G	Combination Valve Nat. Std. Honeywell	601013	601013	601013	601013		
	Combination Valve Pro. Std. Honeywell	601014	601014	601014	601014		
	Combination Valve Nat. Std. Robertshaw	601009	601009	601009	601009	004824F	004824F
	Combination Valve Pro. Std. Robertshaw	601010	601010	601010	601010	004825F	004825F
	Combination Valve Nat. HSI Honeywell	601015F	601015F	601015F	601015F		
	Combination Valve Pro. HSI Honeywell	601016F	601016F	601016F	601016F		
	Combination Valve Nat. HSI Robertshaw	005095F	005095F	005095F	005095F	004826F	004826F
	Combination Valve Pro. HSI Robertshaw	005096F	005096F	005096F	005096F	004827F	004827F
	Combination Valve Nat. IID Honeywell On/Off	006957F	006957F	006957F	006957F	006957F	
	Combination Valve Pro. IID Honeywell On/Off	006958F	006958F	006958F	006958F	006958F	
	Combination Valve Nat. IID Robertshaw On/Off	005461F	005461F	005461F	005461F		
	Combination Valve Pro. IID Robertshaw On/Off	005462F	005462F	005462F	005462F		
	Combination Valve Nat. IID Robertshaw 2 Stage				005463F	005463F	005463F
	Combination Valve Pro. IID Robertshaw 2 Stage				005464F	005464F	005464F
H	HEAT EXCHANGER						
1-H	Heat Exchanger Cast Iron	003945F	003945F	003946F	003946F	004231F	004232F
	Heat Exchanger Brass	003948F	003948F	003949F	003949F	004233F	004234F
2-H	Inlet/Outlet Header Cast Iron	003950F	003950F	003952F	003952F	004235F	004236F
	Inlet/Outlet Header Brass	003951F	003951F	003953F	003953F	004237F	004238F
3-H	Return Header Cast Iron	003954F	003954F	003956F	003956F	004239F	004240F
	Return Header Brass	003955F	003955F	003957F	003957F	004241F	004242F
4-H	Tube Bundle*	003959F	003959F	003960F	003960F	004243F	004244F
5-H	Heat Exchanger Tube	003961F	003961F	003961F	003961F	003961F	003961F
6-H	Baffle Kit	003963F	003963F	003964F	003964F	004245F	004246F
7-H	Carriage Bolt Kit	003965F	003965F	003965F	003965F	004247F	004248F
	Stud Bolt	007912F	007912F	007912F	007912F	007911F	007911F
8-H	Header Gasket	800203B	800203B	800203B	800203B	800203B	800203B
9-H	Sensor Well	007211F	007211F	007211F	007211F	007211F	007211F
10-H	Well Retaining Clip	300203	300203	300203	300203	300203	300203
J	CONTROL BOX						
1-J	Control Box Std. (Complete)	003966F	003966F	003966F	003966F	004249F	004249F
	Control Box Std. 2- Stage (Complete)				007021F	007023F	007023F
	Control Box HSI (Complete)	003967F	003967F	003967F	003967F	004250F	004250F
	Control Box IID Nat/Lock (Complete)	005465F	005465F	005465F	005465F	005466F	005466F
	Control Box IID Nat/Lock 2 Stage (Complete)				007022F	007024F	007024F
2-J	Transformer	650691	650691	650691	650691	650691	650691
3-J	Relay DPST	650518	650518	650518	650518	650518	650518

*FOR ALTITUDES ABOVE 2,000 FEET ABOVE SEA LEVEL, CONSULT FACTORY.

*NUMBER OF TUBES VARIES FOR EACH MODEL SIZE.

NOTE: BOILERS MANUFACTURED AFTER AUGUST 11, 1994, SERIAL #9408116901 OR LATER, HAVE IID IGNITION IN LIEU OF HSI IGNITION.

CALL OUT	DESCRIPTION	30B	42B	66B	90B	135B	180B
M	MISCELLANEOUS						
1-M	PRV 30 PSI	501410	501410	501410	501410	501410	501410
2-M	Delimiting Kit	052871F	052871F	052871F	052871F	052871F	052871F
3-M	T & P Gauge	007205F	007205F	007205F	007205F	007205F	007205F
4-M	Drain Valve	006536F	006536F	006536F	006536F	006536F	006536F
5-M	Pump Inline Taco	003968F	003968F	003968F	004251F	005097F	005097F
	Pump Inline Taco Brass	007340F	007340F	007340F	007340F	007333F	007333F
	Pump Inline Grundfos					004714F	004714F
6-M	Pump Cartridge (Taco)	951116F	951116F	951116F	951116F	951166F	951166F
7-M	Wire/Harness Std.	003969F	003969F	003969F	003969F	004256F	004256F
	Wire/Harness Std. 2 Stage				007044F	007044F	007044F
	Wire/Harness HSI Honeywell	003970F	003970F	003970F	003970F	004257F	004257F
	Wire/Harness HSI Fenwal	003971F	003971F	003971F	003971F	004258F	004258F
	Wire/Harness IID	005602F	005602F	005602F	005602F	005603F	005603F
	Wire/Harness IID 2 Stage				007045F	007045F	007045F
8-M	Flange Gasket	009063F	009063F	009063F	009063F	009064F	009064F
9-M	Bypass Group	009065F	009065F	009065F	009065F	009066F	009066F
P	PILOT						
1-P	Pilot Nat. Std.	003972F	003972F	003972F	003972F	003972F	003972F
	Pilot Pro. Std.	003973F	003973F	003973F	003973F	003973F	003973F
	Pilot Nat. IID	005467F	005467F	005467F	005467F	005467F	005467F
	Pilot Pro. IID	005468F	005468F	005468F	005468F	005468F	005468F
2-P	Pilot Orifice Nat. Std.	003974F	003974F	003974F	003974F	003974F	003974F
	Pilot Orifice Pro. Std.	003975F	003975F	003975F	003975F	003975F	003975F
	Pilot Orifice Nat. IID	003903F	003903F	003903F	003903F	003903F	003903F
	Pilot Orifice Pro. IID	004308F	004308F	004308F	004308F	004308F	004308F
3-P	Pilot Thermocouple	600003	600003	600003	600003	600003	600003
4-P	Hot Surface Ignitor HSI	003976F	003976F	003976F	003976F	003976F	003976F
5-P	Ignition Control HSI Honeywell	601005F	601005F	601005F	601005F	601005F	601005F
	Ignition Control HSI Fenwal	601129F	601129F	601129F	601129F	601129F	601129F
	Ignition Control IID Honeywell	004935F	004935F	004935F	004935F	004935F	004935F
6-P	Pilot Mtg. Bracket	306239	306239	306239	306239	306239	306239
8-P	Pilot Tube	400275	400275	400275	400275	400275	400275
9-P	High Tension Wire IID	002654B	002654B	002654B	002654B	002654B	002654B
	High Tension Wire w/Pilot Electrode	007864F	007864F	007864F	007864F	007864F	007864F
R	REFRACTORY						
1-R	Refractory Kit	003977F	003977F	003978F	003978F	004259F	004260F
S	SHEETMETAL						
1-S	Jacket-Top	003979F	003979F	003980F	003980F	004261F	004268F
2-S	Flue Collector	003981F	003981F	003982F	003982F	004262F	004263F
3-S	Access Panel	003983F	003983F	003983F	003983F	004264F	004264F
4-S	Control Panel Cover	003984F	003984F	003984F	003984F	004265F	004265F
5-S	Jacket-Left	009170F	009170F	009170F	009170F	009170F	009170F
	Jacket-Right	009171F	009171F	009171F	009171F	009171F	009171F
	Jacket-Rear	009172F	009172F	009172F	009172F	009173F	009173F
V	VENTING						
1-V	Drafthood	003985F	003985F	003986F	003986F	004266F	004267F
2-V	Vent Damper	004709	004709	004710	004710	004711	004712

GAS CONVERSION KITS **	30B	42B	66B	90B	135B	180B
HONEYWELL GAS VALVE						
Standing Pilot Nat. to Pro.	004269F	004273F	004698F	004277F		
Standing Pilot Pro. to Nat.	004270F	004274F	004699F	004278F		
Hot Surface Ignition Nat. to Pro.	004271F	004275F	004700F	004279F		
Hot Surface Ignition Pro. to Nat.	004272F	004276F	004701F	004280F		
IID Nat. to Pro. Honeywell	005471F	005473F	005475F	005477F		
IID Pro. to Nat. Honeywell	005472F	005474F	005476F	005478F		
ROBERTSHAW GAS VALVE						
Standing Pilot Nat. to Pro.	004289F	004293F	004702F	004297F	004281F	004285F
Standing Pilot Pro. to Nat.	004290F	004294F	004703F	004298F	004282F	004286F
Hot Surface Ignition Nat. to Pro.	004291F	004295F	004704F	004299F	004283F	004287F
Hot Surface Ignition Pro. to Nat.	004292F	004296F	004705F	004300F	004284F	004288F
IID Nat. to Pro. Robertshaw	005479F	005481F	005483F	005485F	005487F	005489F
IID Pro. to Nat. Robertshaw	005480F	005482F	005484F	005486F	005488F	005490F

** Gas Conversions are to be done only by a Qualified Agency.

IGNITION CONTROL CONVERSION KIT	
Robertshaw HSI Control to Fenwal HSI Control	004678F

NOTE: BOILERS MANUFACTURED AFTER AUGUST 11, 1994, SERIAL #9408116901 OR LATER, HAVE IID IGNITION IN LIEU OF HSI IGNITION.



**LIMITED PARTS WARRANTY
RESIDENTIAL HEATING BOILERS
MODELS 42 TO 180**

Catalog No.: 1910.10H
Effective: 01-01-04
Replaces: 05-15-03

SCOPE:

Raypak, Inc. ("Raypak") warrants to the original owner that all parts of this boiler which are actually manufactured by Raypak will be free from failure under normal use and service for the specified warranty periods and subject to the conditions set forth in this Warranty. Labor charges and other costs for parts removal or reinstallation, shipping and transportation are not covered by this Warranty but are the owner's responsibility.

ANY PART MANUFACTURED BY RAYPAK:

One (1) year warranty from date of boiler installation, or eighteen (18) months from date of factory shipment based on Raypak's records, whichever comes first.

SATISFACTORY PROOF OF INSTALLATION DATE, SUCH AS INSTALLER INVOICE, IS REQUIRED. THIS WARRANTY WILL BE VOID IF THE BOILER RATING PLATE IS ALTERED OR REMOVED.

HEAT EXCHNAGER WARRANTY:

Second through tenth years from date of installation, Raypak warrants that the copper and cast iron waterway are free from defects in material and workmanship. If any of these parts are found defective Raypak will replace or repair free of charge subject to conditions listed under "Scope" above.

Eleventh through twentieth years from date of installation, Raypak warrants that the copper and cast iron waterways are free from defects in material and workmanship. If any of these parts are found defective Raypak will replace the original parts and payment of a proportionate charge equal to 1/120th of the list price of such parts, at the time the warranty claim is made, for each month, or portion thereof, beyond the tenth year.

ADDITIONAL WARRANTY EXCLUSIONS:

This warranty does not cover failures or malfunctions resulting from:

1. Failure to properly install, operate or maintain the boiler in accordance with our printed instructions provided;
2. Abuse, alteration, accident, fire, flood and the like;
3. Sediment or lime buildup, freezing, or other conditions causing inadequate water circulation;
4. High velocity flow exceeding boiler design rates;
5. Failure of connected systems devices, such as pump or controller;
6. Use of non-factory authorized accessories or other components in conjunction with the boiler system;
7. Failure to eliminate air from, or replenish water in, the connected water system;
8. Chemical contamination of combustion air or use of chemical additives to water;
9. Boilers installed in buildings other than one- or two-family dwellings.

PARTS REPLACEMENT:

Under this Warranty, Raypak will furnish a replacement for any failed part. The failed part must first be returned to Raypak if requested, with transportation charges prepaid, and all applicable warranty conditions satisfied. The replacement part will be warranted for only the unexpired portion of the original warranty. Raypak makes no warranty whatsoever on parts manufactured by others, but Raypak will apply any such warranty as may be provided by the parts manufacturers.

TO MAKE WARRANTY CLAIM:

Promptly notify the original installer, supplying the model and serial numbers of the unit, date of installation and description of the problem. The installer must then notify a Raypak distributor for instructions regarding the claim. If neither the installer nor the distributor is available, contact Service Manager, Raypak, Inc., 2151 Eastman Avenue, Oxnard, CA 93030 or call (805) 278-5300. In all cases proper authorization must first be received from Raypak before replacement of any part.

EXCLUSIVE WARRANTY - LIMITATION OF LIABILITY:

This is the only warranty given by Raypak. No one is authorized to make any other warranties on Raypak's behalf. THIS WARRANTY IS IN LIEU OF ALL OTHER WARRANTIES, EXPRESS OR IMPLIED, INCLUDING BUT NOT LIMITED TO IMPLIED WARRANTIES OF MERCHANTABILITY AND FITNESS FOR A PARTICULAR PURPOSE. RAYPAK'S SOLE LIABILITY AND THE SOLE REMEDY AGAINST RAYPAK WITH RESPECT TO DEFECTIVE PARTS SHALL BE AS PROVIDED IN THIS WARRANTY. IT IS AGREED THAT RAYPAK SHALL HAVE NO LIABILITY, WHETHER UNDER THIS WARRANTY, OR IN CONTRACT, TORT, NEGLIGENCE OR OTHERWISE, FOR ANY SPECIAL, CONSEQUENTIAL, OR INCIDENTAL, DAMAGE, INCLUDING DAMAGE FROM WATER LEAKAGE. Some states do not allow limitations on how long an implied warranty lasts, or for the exclusion of incidental or consequential damages. So the above limitation or exclusion may not apply to you.

This Limited Warranty gives you specific legal rights. You may also have other rights which may vary from state to state. We suggest that you complete the information below and retain this certificate in the event warranty service is needed. Reasonable proof of the effective date of the warranty (date of installation) must be presented, otherwise, the effective date will be based on the date of manufacture plus thirty (30) days.

Name of Owner

Name of Installer

Address

Address

Model No.

Serial No.

Date of Installation

Date of Initial Operation

RAYPAK, INC. • 2151 Eastman Avenue • Oxnard, CA 93030 • (805) 278-5300 • Fax (800) 872-9725 • www.raypak.com



www.raypak.com