INTRODUCTION

Congratulations. You've just purchased the best amplifier in car audio. It's only natural that an amplifier this good would be called a KICKER. Over the last decade Stillwater Designs has established KICKER as the premier car audio speaker. The name is synonymous with rugged design, outstanding performance, and timeless quality. A KICKER tradition that is continued in your new amplifier.

From the cast aluminum base to the completely functional heat sink, this amp is built for performance. Uncompromising attention to detail, flexibility and pure clean power, KICKER Car Audio Amplifiers—The way amplifiers *ought to be*.

Stillwater Designs recommends that the KICKER Amplifier be installed at an authorized dealer. The length of your KICKER Amplifier's warranty is three times as long when installed by an authorized KICKER Dealer.

FEATURES & CONTROLS

Your new KICKER Power Amplifier incorporates today's most advanced and innovative design techniques. Three different circuits provide continuous protection from the severe conditions associated with car audio. These are thermal, speaker short, and reversed power connections. The high input impedance allows for multiple amplifiers to be daisy-chained from a single source, without degrading the signal. The custom tooled connectors provide positive contact for power and speaker connections, while allowing maximum gauge wires to be used effectively. An optional plug-in module can provide active equalization and crossover functions. The output of this module can be directed to successive amplifiers through the signal output of the initial amplifier. All these features are included in an attractive and easy to install chassis.

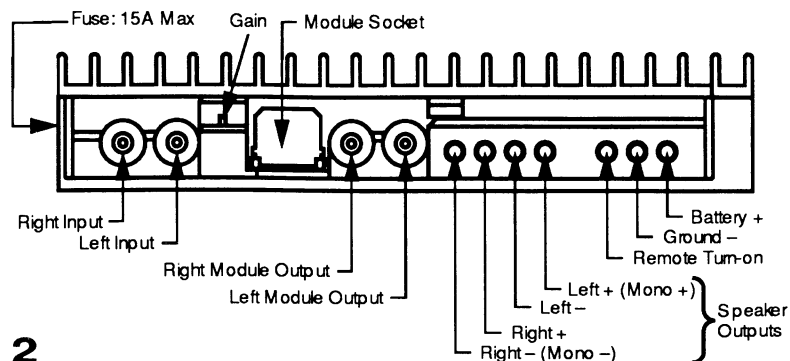

WIRING INSTRUCTIONS

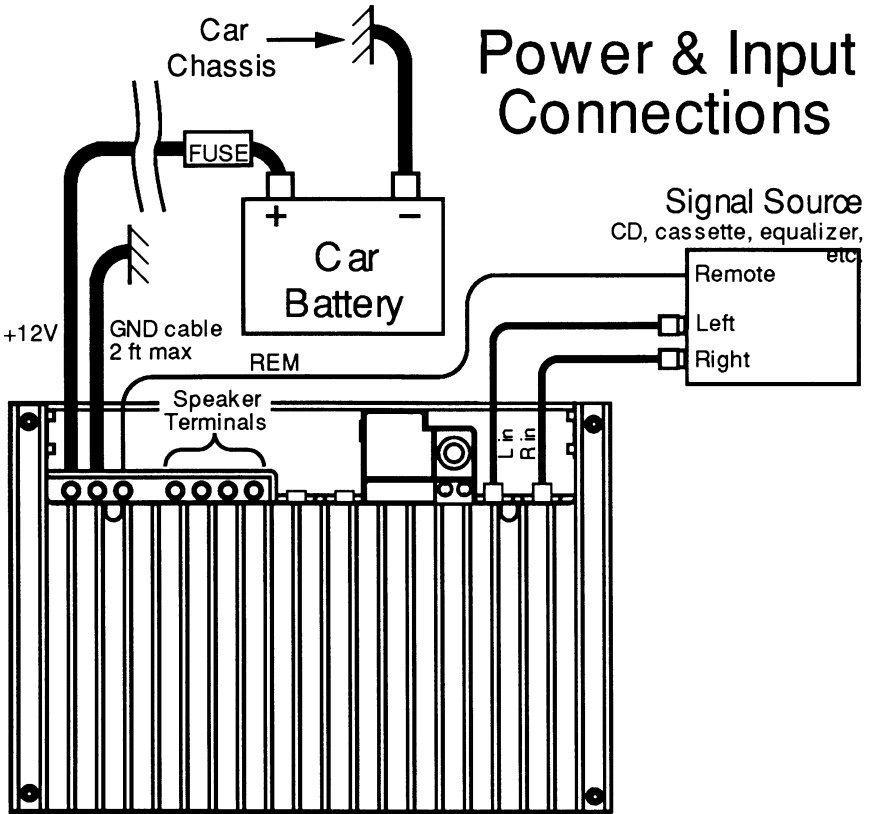

Your KICKER amplifier requires 8 gauge power wires for both power and ground connections. Always make the ground connection first when installing this amplifier and disconnect ground last when removing it from the system. Connect the ground wire, which is 24 inches or less, to a structural chassis member. Be sure this connection is to bare metal and securely screwed or bolted. (It is not recommended to run the ground wire to the battery.) Run the positive wire directly to the positive terminal of the battery and use a 30 amp fuse within 18 inches of the battery. This fuse protects the wire run from the battery. Run the power and signal wires on opposite sides of the car. This helps to reduce noise in the signal wires between the source and the amplifier. The speaker connections can accept up to 8 gauge wire to reduce losses in long runs.

The cover panel allows for two wiring methods; standard and stealth. The standard method requires the removal of a break-away panel, as shown in the following diagram.

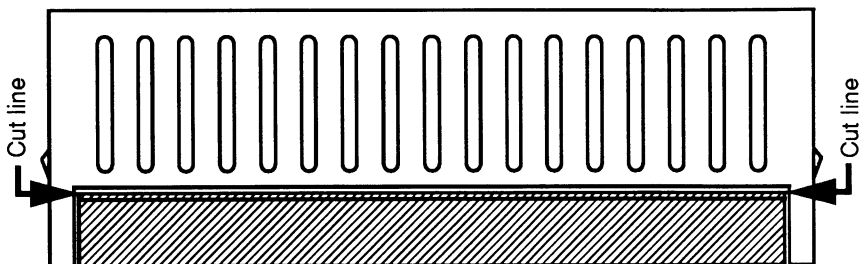

Back view of cover panel showing removable breakout section (darkened area)

The breakout panel is removed by scoring the groove with a razor knife and bending the shaded portion away from the cut. The remaining edge can then be touched up with a small file. This allows the wiring to be run directly out of the control panel side of the amplifier.

The opening in the base of the amplifier allows the wiring to travel through the base without altering the cover panel for a stealth look, which is often preferred for custom installations. With this method, short right angle RCA connectors are required for the signal connections.

Caution: Do not route the wires beneath the vehicle without proper protection. Do not pinch wires beneath seat frames or trim panels.

Caution: Do not ground speaker leads.

MOUNTING INSTRUCTIONS

The orientation of the amplifier is critical to provide proper cooling. The cooling fins are designed to operate best when run in a vertical position or mounted horizontally with the fins up. The mounting feet can be attached so they are positioned to the end or the edge of the amplifier, whichever works best for you.

Amps mounted side by side with mounting feet to the top and bottom.

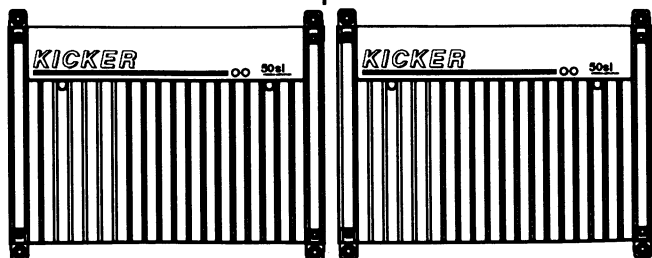

Amps stacked vertically with the mounting feet to the sides

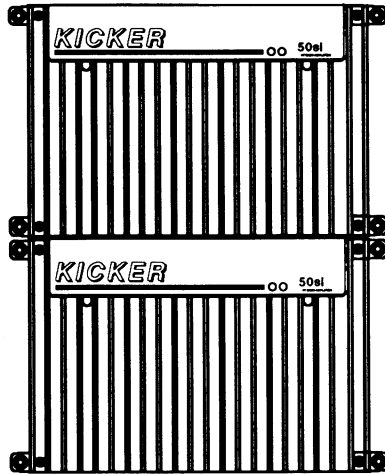

Stealth mounting is accomplished by using the template provided in the box. The template shows where the screw holes are located and where the mounting surface must be cut out to run the wires. A #6 sheet metal screw must be used when stealth mounting the amplifier. The chart on the template shows the screw length needed for the thickness of mounting board used.

Since the case of the amplifier is part of the noise shielding system in the amplifier, it is necessary to mount it to a non-conductive surface. Mounting the amplifier to chassis ground will cause engine noise.

Without Feet

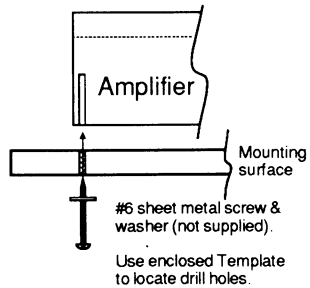

With Feet

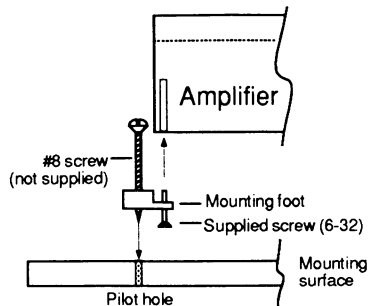

SYSTEM DIAGRAMS

Two Channel Operation

In conventional stereo or two channel operation, a signal input is required for each channel and a speaker load of no less than 2 ohms is connected to the right and left outputs.

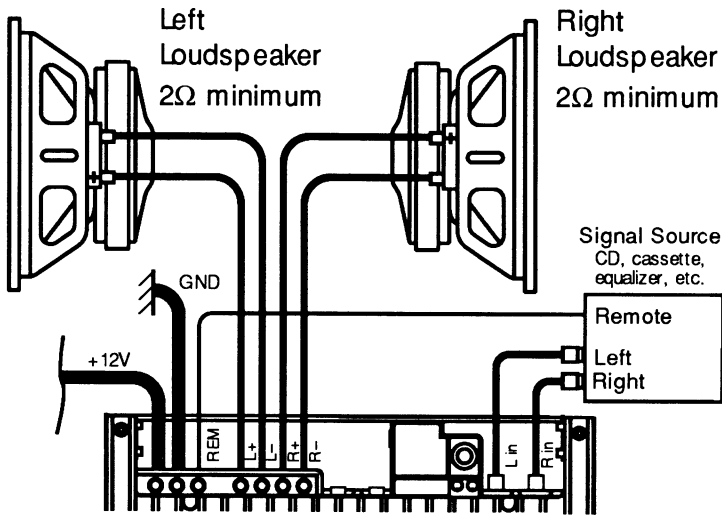

Bridged Operation

For bridged mono systems an input is required to both input connectors and the speaker load of no less than 4 ohms is connected to the left+ and right-.

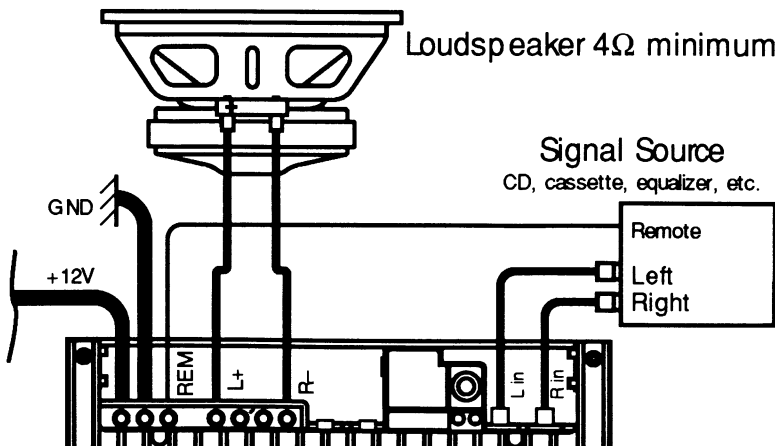

Three Channel (Mixed Mono) Operation (Left Channel, Right Channel & Subwoofer Channel)

The upper frequency drivers are connected in stereo while the mono woofer is connected from the left+ to the right-. A typical crossover point would be 100 Hz. These systems require the use of passive crossovers to maintain proper impedance loads at all frequencies.

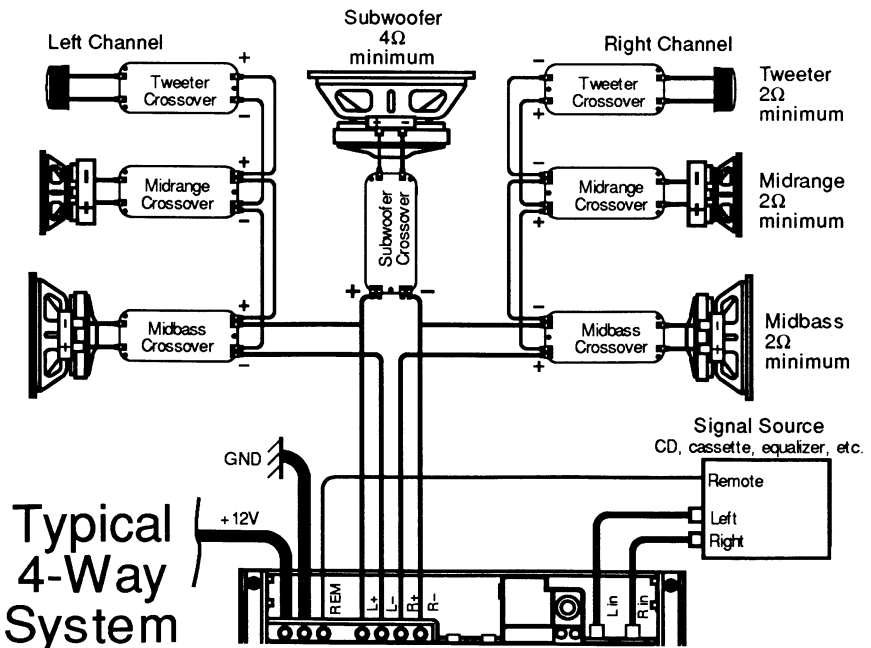
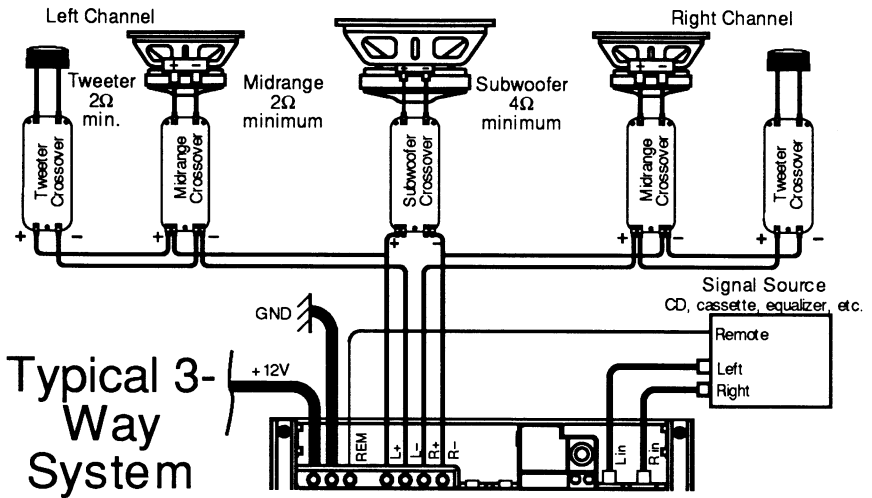

Daisy Chaining Amplifiers

When operating more than one amplifier in the same frequency range it is possible to connect the input of the next amplifier to the output of the first. Daisy chaining requires only one source for several amplifiers.

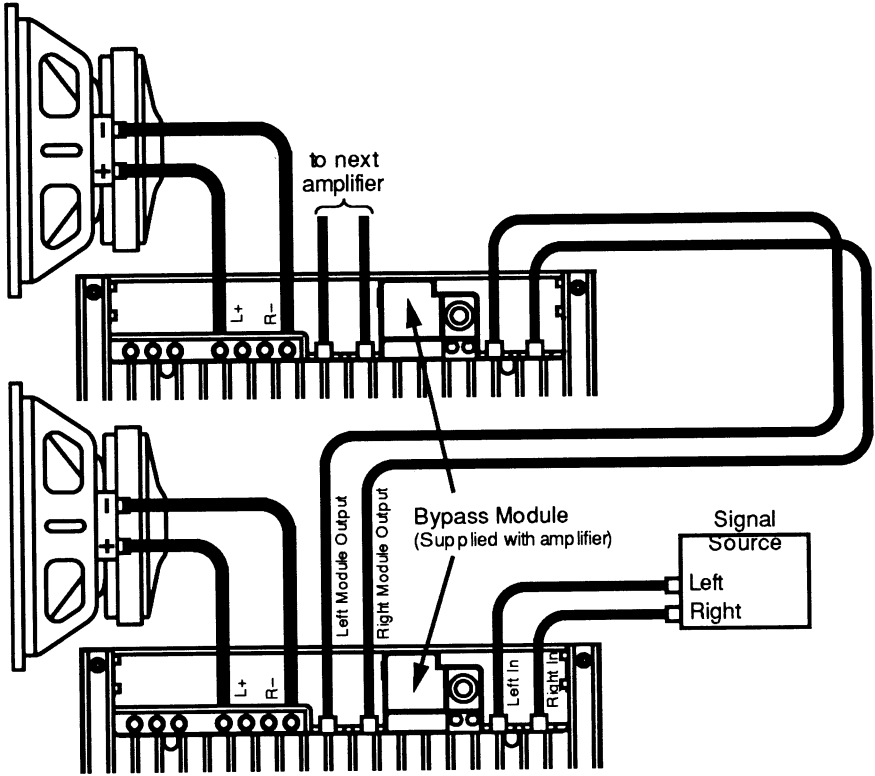

SETTING GAIN CONTROL

The gain control is provided for level matching purposes. It DOES NOT give the amplifier any more power by turning it up. Its purpose is to adjust the sensitivity of the amplifier in relation to the output level provided by the source.

Start with the amp gain set to minimum by turning the control counter-clockwise. Turn the source level up until distortion is barely audible. Then turn it down slightly. This will typically be at about 75% to 85% of full volume. Raise the amplifier gain until distortion is just audible. The gain is now set correctly. Check the level with cd/tape and tuner to make sure the adjustment is correct for all sources.

OPTIONAL MODULES

All KICKER amplifiers have a Module Docking Port, which allows the use of any KICKER Module. These modules greatly increase your amplifier's versatility, and cost very little when compared to "stand alone" units with the same functions. When not using a KICKER Module, the Bypass Module supplied with your amp must be left in place.

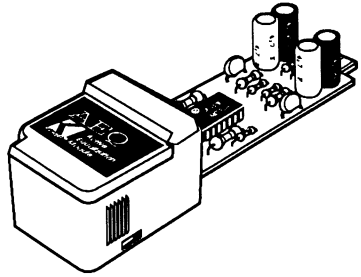

Active Crossover Modules: ASW, AMR, and ATW

These 2-way modules allow you to use separate amplifiers for your subwoofers, midbass drivers, midranges, or tweeters. By doing this, especially on the subwoofer, a clean and undistorted sound is available at much higher listening levels.

Each module offers a range of selectable crossover frequencies and 24dB/octave filtering.

- ASW—60Hz, 80Hz, or 100Hz subwoofer/midbass or midrange crossover.
- AMR—175Hz, 250Hz, or 350Hz midbass/midrange crossover.
- ATW—3500Hz or 4500Hz midrange/tweeter crossover.

Specialty Modules: AEQ and ACR

- AEQ—Frequency Enhancement and extension in the low bass region as well as the upper treble.
- ACR—This module allows one amplifier to drive a center channel and rear speakers independently at the same time.

Consult with your authorized KICKER dealer for more information.

TROUBLE SHOOTING

■ Power indicator off, no output.

With a Volt Ohm Meter (VOM),

- Check +12V power terminal.
- Check GND terminal.
- Check remote turn-on terminal.

■ Power indicator on, no output.

- Check RCA and speaker connections.
- Test speaker outputs with known good test speaker.
- With VOM in AC volts position, check RCA for input voltage.

■ **No output from one channel.**

Check RCA and speaker connections on that channel.

Swap RCA connections between channels.

Swap speaker connections between channels.

■ **Yellow LED protection light is on and there is no output.**

Case 1: Amp is very hot.

Thermal protection is engaged. Verify that speaker load impedance is not below specified minimums. Check area surrounding amplifier for objects which may restrict air flow and proper cooling. If this continues to be a problem, take vehicle to an authorized KICKER dealer for evaluation.

Case 2: Output resumes momentarily when system is turned off and then back on.

Short circuit protection is engaged. Verify that speaker load impedance is not below specified minimums. With VOM check for short between speaker positive and negative, and between speakers and chassis ground. If unable to perform task or locate problem, take vehicle to an authorized KICKER dealer for evaluation.

■ **Alternator noise (a whining that varies with engine RPM.)**

Make sure source grounds are as short as possible and connected to bare chassis metal, not to factory radio ground. Beware of dash braces. Many are not grounded to chassis. Check RCA cable for proper connections and routing. Try another cable routed in a different location in the vehicle. If unable to cure problem, take vehicle to an authorized KICKER dealer for evaluation.

■ **Stereo image is unfocused and bass is reduced.**

Check system phasing by turning the balance control to the left and right speakers. If bass is more prominent when turned to either side, check speaker wiring for proper positive and negative connections. Reverse connections on one speaker if necessary.

Caution: *When jump starting the vehicle, be sure that connections made with jumper cables are correct. If improper connections are made, it can result in blown fuses in the amplifier power line as well as other systems in the vehicle.*

SPECIFICATIONS

- Number of channels 2
 - Rated power/channel into 4Ω, no more than 0.01% THD,
20Hz to 20KHz, both channels driven 25W
 - Rated power/channel into 2Ω, no more than 0.02% THD,
20Hz to 20KHz, both channels driven 42.5W
 - Bridged power into 4Ω, no more than 0.02% THD,
20Hz to 20KHz 85W
 - Max Current Draw, 2Ω stereo load or 4Ω bridged load 15A
 - Frequency Response, +0, -1dB 10 Hz to 28 KHz
 - Signal to Noise Ratio, unweighted,
relative to rated power/channel into 4Ω >100 dB
 - Input Impedance 22 KΩ
 - Input Sensitivity range 250mV – 5V
-
-

CAUTION

Stillwater Designs and the Electronic Industries Association's Consumer Electronics Group want you to get the most out of your equipment by playing it at a safe level.

Sound can be deceiving. Over time your hearing “comfort level” adapts to higher volumes of sound, so what sounds “normal” can actually be loud and harmful to your hearing. Guard against this by setting your equipment at a safe level BEFORE your hearing adapts.

- Start your volume control at a low setting.
- Slowly increase the sound until you can hear it comfortably and clearly without distortion.
- Once you have established a comfortable level:
- Set the dial and leave it there. Taking a minute to do this now will help to prevent hearing loss or damage in the future. After all, we want you listening for a lifetime.

<i>Decibel Level</i>	<i>Example</i>
30	<i>Quiet library, soft whispers</i>
40	<i>Living room, refrigerator, bedroom away from traffic</i>
50	<i>Light traffic, normal conversation, quiet office</i>
60	<i>Air conditioner at 20 feet, sewing machine</i>
70	<i>Vacuum cleaner, hair dryer, noisy restaurant</i>
80	<i>City traffic, garbage disposals, alarm clock at two feet.</i>

<i>The following noises can be dangerous under constant exposure</i>	
90	<i>Subway, motorcycle, truck traffic, lawn mower</i>
100	<i>Garbage truck, chain saw, pneumatic drill</i>
120	<i>Rock concert in front of speakers, thunderclap</i>
140	<i>Gunshot blast, jet plane</i>
180	<i>Rocket launching pad</i>



STILLWATER

Designs®

(Mail Only)
PO Box 459
Stillwater, OK 74076
(405)624-8510

LIMITED WARRANTY

Stillwater Designs warrants this product to be free from defects in material and workmanship under normal use and conditions for a period of three (3) years from date of original purchase when installed by an authorized dealer, or one (1) year from date of original purchase when not installed by an authorized dealer. Should service be necessary under this warranty for any reason due to manufacturing defect or malfunction during the warranty period, Stillwater Designs will replace or repair (at its discretion) the defective merchandise at no charge. This warranty covers parts and labor.

This warranty is valid only for the original purchaser and is not extended to owners of the product subsequent to the original purchaser. Any applicable implied warranties are limited in duration to a period of the express warranty as provided herein beginning with the date of original purchase at retail, and no warranties, whether express or implied shall apply to this product thereafter. Some states do not allow limitations on implied warranties, therefore these exclusions may not apply to you. This warranty gives you specific legal rights, however you may have other rights that vary from state to state.

What to do:

Defective or otherwise unserviceable merchandise must be returned to your local authorized Stillwater Designs (KICKER) dealer for warranty. Assistance in locating an Authorized Dealer or Service Center can be obtained by writing or calling Stillwater Designs direct. You can confirm that a dealer is authorized for service by verifying that an Authorized Dealer certificate is on display.

Any questions can be directed to the Warranty Department at (405) 624-8510.

What is not covered?

This warranty is valid only if the product is used for the purpose for which it was designed. It does not cover:

- Damage through negligence, misuse, abuse or accident.
- Damage caused by exposure to moisture, and/or excessive heat.
- Items repaired or modified by an unauthorized repair facility or individual.
- Bent or otherwise modified amplifier housings.
- Items returned from unauthorized individuals or dealers.
- Items returned without proof of purchase from an authorized KICKER dealer.
- The cost of shipping this product to Stillwater Designs (KICKER) Service.

International Warranty

Contact your international Stillwater Designs (KICKER) dealer or distributor concerning specific procedures for your country's policies, or contact us direct.

SERIAL NUMBER
