

**INTERNATIONAL®  
CUB CADET®  
182, 282H,  
382 and 382H  
LAWN TRACTORS**

INTERNATIONAL®

# OPERATOR'S MANUAL

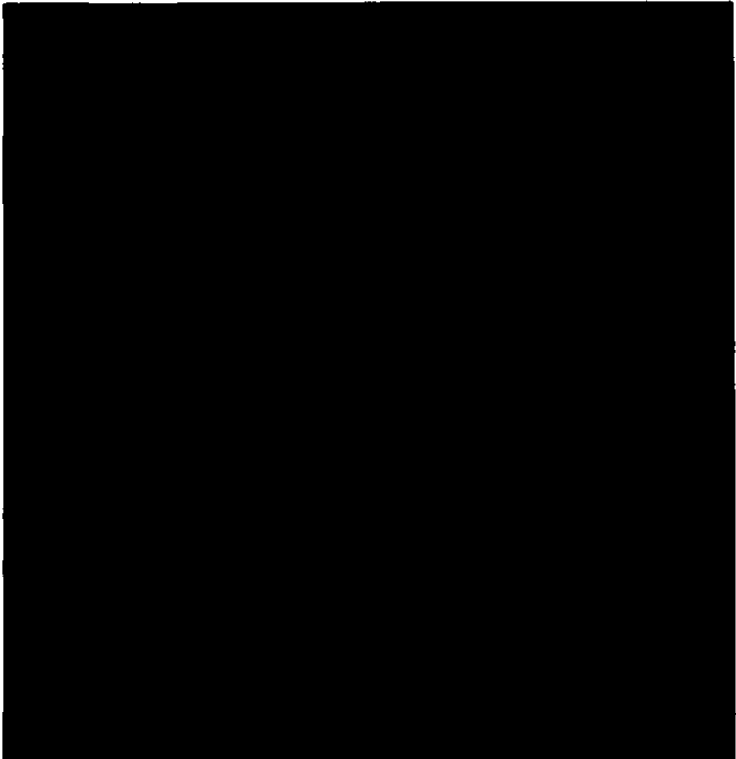

## To The Owner

Your new Cub Cadet® Lawn Tractor is designed to meet today's exacting operating requirements. It is built for efficient, economical performance, ease of operation, and with the ability to adjust to various conditions. These features lighten your work and shorten your hours on the job.

You are urged to consult your authorized dealer concerning unusual conditions or special applications. Let the experience of your dealer and the organization associated with him serve you.

Be sure to read the instructions for Adjusting and Operating in this manual. Check each item referred to and acquaint yourself with the adjustments required to obtain efficient operation and maximum trouble-free service. Remember, a lawn tractor which is properly lubricated and adjusted saves time and labor.

After the cutting season, thoroughly clean your lawn tractor and inspect it. Preventative maintenance pays dividends. Your dealer has original-equipment parts which assure proper fit and best performance. He is able to recondition your equipment to a like new condition.

When in need of parts, always specify the model, chassis and engine serial numbers, including any prefix or suffix letters. Write these serial numbers in the spaces provided. **See page 3.**

Additional copies of this manual may be ordered from your authorized dealer at a nominal price.

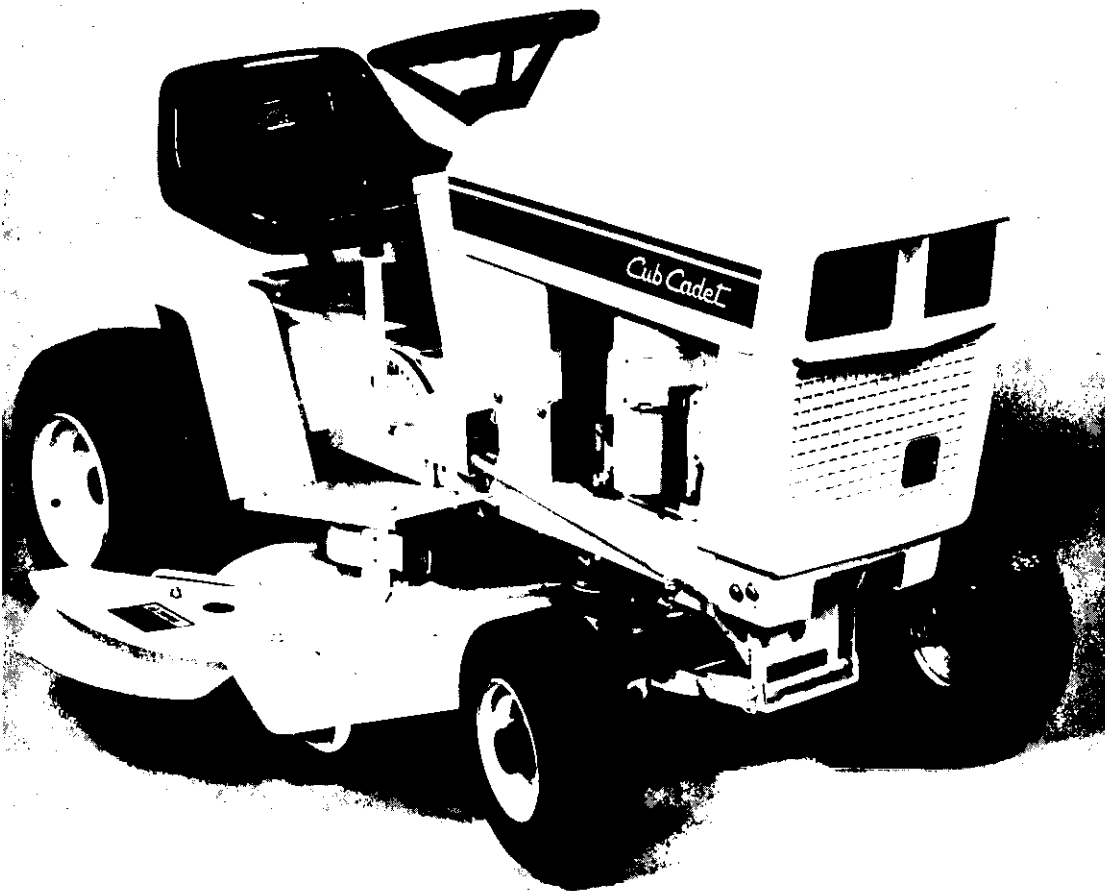

**Model 382H Shown**

# CONTENTS

Description	Page	Description	Page
<b>TO THE OWNER</b>	1	Leveling the Mower	15, 16
<b>SERIAL NO. LOCATION</b>	3	Mower Drive V-Belt	16
<b>INTRODUCTION</b>	3	Crankshaft Main Drive and Hydrostatic Final Drive Belts	
<b>SAFE OPERATING PRACTICES</b>	4, 5	—Hydrostatic Models	16 to 19
<b>ENERGY CONSERVATION— FOLLOW THESE RECOMMENDATIONS</b>	5	Crankshaft Main Drive and Final Drive Belts —Gear Drive Models	20 to 22
<b>INSTRUMENTS AND CONTROLS</b>	6 to 10	<b>FUEL SYSTEM</b>	23
<b>BEFORE OPERATING THE ENGINE</b>	10	<b>ELECTRICAL SYSTEM</b>	24, 25
<b>OPERATING THE ENGINE</b>	11	<b>ENGINE COOLING AND AIR CLEANER</b>	25
<b>DRIVING THE LAWN TRACTOR</b>	12, 13	<b>STORING THE LAWN TRACTOR</b>	25, 26
<b>ADJUSTING AND OPERATING</b>	13 to 23	<b>LUBRICATION</b>	26, 27
Adjusting the Seat	13, 14	<b>LUBRICATION GUIDE</b>	27 to 29
Cleaning the Mower	14	<b>LUBRICATION TABLE</b>	30
Height of Cut	14	<b>MAINTENANCE GUIDE</b>	30, 31
Blade Care	14	<b>TROUBLE SHOOTING</b>	31 to 32
Adjusting the Brakes	14	<b>SPECIFICATIONS</b>	33
Seat Safety Switch	14		
Attaching and Detaching the Mower	14, 15		



## WARNING

### TO PURCHASERS OF INTERNAL COMBUSTION ENGINE EQUIPPED MACHINERY OR DEVICES IN THE STATE OF CALIFORNIA

The equipment which you have just purchased does not have a spark arrester. If this equipment is used on any forest covered land, brush covered land, or grass covered unimproved land in the State of California, before using on such land, the California law requires that a spark arrester be provided. In addition, spark arrester is required by law to be in effective working order. The spark arrester must be attached to the exhaust system and comply with Section 4442 of the California Public Resources Code.

# SERIAL NUMBER LOCATION

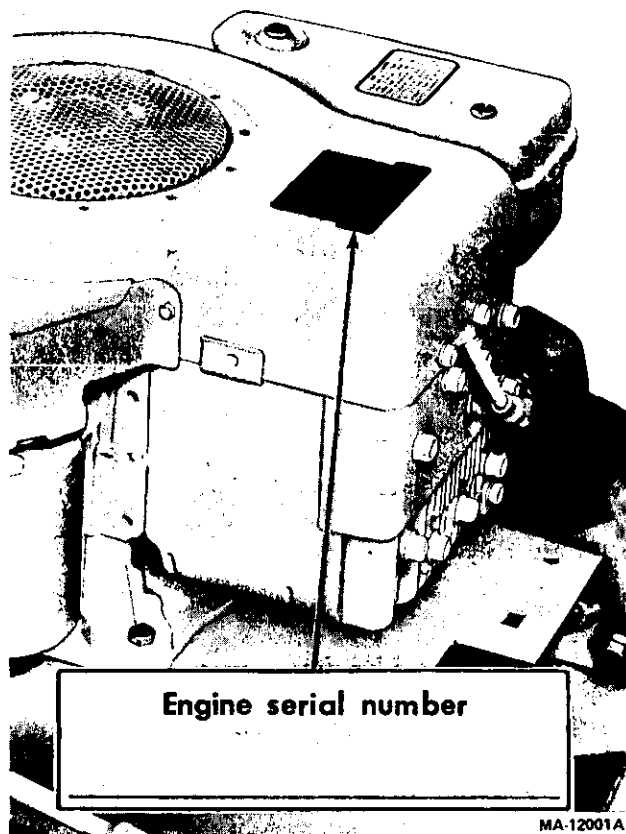
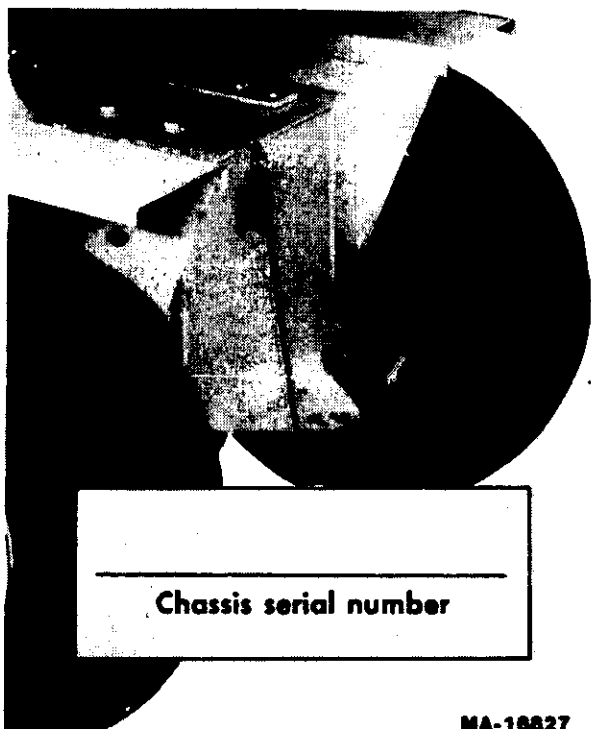

DELIVERY DATE:

## INTRODUCTION

Assembled in this manual are operating, maintenance and lubrication instructions for the Cadet 182, 282H, 382 and 382H lawn tractors. This material has been prepared in detail in the hope that it will help you to better understand the correct care and efficient operation of the tractor.

LEFT and RIGHT indicate the left and right sides of the lawn tractor when facing forward in the driver's seat.



Instructions given with this symbol are for personal safety. Be sure you and your workers follow them.

To reduce the potential for any injury, comply with the following safety instructions. Failure to comply with the instructions may result in personal injury.

## SAFE OPERATION PRACTICES FOR RIDING VEHICLES

1. It is suggested that this manual be read in its entirety before attempting to assemble or operate this unit. Keep this manual in a safe place for future reference and for ordering replacement parts.
2. This unit is a precision piece of power equipment, not a plaything. Therefore exercise extreme caution at all times.
3. Know the controls and how to stop quickly—**READ THIS OWNER'S MANUAL.**
4. Do not allow children to operate vehicle. Do not allow adults to operate it without proper instruction. Only persons well acquainted with these rules of safe operation should be allowed to use your mower.
5. No one should operate this unit while intoxicated or while taking medication that impairs the senses or reactions.
6. Wear sturdy, rough-soled work shoes and close-fitting slacks and shirts to avoid entanglement in the moving parts. Never operate a tractor in bare feet, sandals, or sneakers.
7. To prevent injury, do not carry passengers or give rides. (Keep children, pets and bystanders out of the area while mowing.) Only the operator should ride on the unit and only in the seat.
8. Check overhead clearance carefully before driving under power lines, guy wires, bridges, low hanging tree branches, before entering or leaving buildings, or in other situations where the operator may be struck or pulled from the tractor which could result in serious injury.
9. To maintain control of the tractor and reduce the possibility of upset or collision operate the tractor smoothly—avoid erratic operation and excessive speed.
10. Keep the area of operation clear of all persons, particularly small children and pets. Stop engine when they are in the vicinity of your mower. Although the area of operation should be completely cleared of foreign objects, a small object may have been overlooked and could be accidentally thrown by the mower in any direction and cause injury.
11. Clear work area of objects which might be picked up and thrown by the mower in any direction and cause injury.
12. Stop the blade(s) when crossing gravel drives, walks or roads.
13. Disengage all attachment clutches and shift into neutral before attempting to start engine.
14. Disengage power to attachment(s) and stop engine before leaving operating position.
15. Do not put hands or feet near or under rotating parts. Keep clear of the discharge opening at all times as the rotating blade(s) can cause injury.
16. Disengage power to attachment(s) and stop engine before making any repairs or adjustments. Disconnect the spark plug wire and keep the wire away from the plug to prevent accidental starting.
17. Before attempting to unclog the mower or discharge chute, stop the engine. The mower blade(s) may continue to rotate for a few seconds after the engine is shut off. Therefore, be sure the blade(s) have stopped completely. Disconnect the spark plug wire and keep the wire away from the plug to prevent accidental starting.
18. Disengage power to attachment(s) when transporting or not in use.
19. Take all possible precautions when leaving vehicle unattended such as disengaging power-take-off, lowering attachments, shifting into neutral, setting parking brake, stopping engine and removing key.
20. Do not stop or start suddenly when going uphill or downhill. Mow up and down face of steep slopes; never across the face.
21. Reduce speed on slopes and in sharp turns to prevent tipping or loss of control. Always keep the tractor in gear when going down steep hills to take advantage of engine braking action.
22. Stay alert for holes in terrain and other hidden hazards.
23. Use care when pulling loads or using heavy equipment.
  - A. Use only approved drawbar hitch points.
  - B. Limit loads to those you can safely control.
  - C. Do not turn sharply. Use care when backing.
  - D. Use counterweight(s) or wheel weights when suggested in owner's manual.
24. Watch out for traffic when crossing or near roadways.
25. When using any attachments, never direct discharge of material toward bystanders nor allow anyone near vehicle while in operation.
26. Handle gasoline with care. It is highly flammable.
  - A. Use approved gasoline container.
  - B. Never remove cap or add gasoline to a running or hot engine or fill fuel tank indoors. Wipe up spilled gasoline.
  - C. Open doors if engine is run in garage. Exhaust fumes are dangerous. Do not run engine indoors.
27. Keep the vehicle and attachments in good operating condition, and keep safety devices in place. Use guards as instructed in operator's manual.

28. Keep all nuts, bolts, and screws tight to be sure the equipment is in safe working condition.
29. Never store the equipment with gasoline in the tank inside a building where fumes may reach an open flame or spark. Allow engine to cool before storing in any enclosure.
30. To reduce fire hazard, keep engine free of grass, leaves or excessive grease.
31. The vehicle and attachments should be stopped and inspected for damage after striking a foreign object. The damage should be repaired before restarting and operating the equipment.
32. Do not change the engine governor settings or overspeed the engine.
33. When using the vehicle with mower, proceed as follows:
  - (1) Mow only in daylight or in good artificial light.
  - (2) Never make a cutting height adjustment while engine is running if operator must dismount to do so.
- (3) Shut the engine off and wait until the blade comes to a complete stop before removing the grass catcher.
- (4) Check blade mounting bolts for proper tightness at frequent intervals.
34. Check grass catcher bags frequently for wear or deterioration. For safety protection, replace only with new bag meeting original equipment specifications.
35. Look behind to make sure the area is clear before placing the transmission in reverse and continue looking behind while backing up.
36. Whenever possible, avoid driving the tractor on an incline such as a ramp or slope. If necessary to move the tractor on an incline, whenever practical back the tractor up the incline and drive the tractor forward down the incline. Use extreme caution if it is necessary to drive the tractor up an incline or back the tractor down an incline because the front of the tractor could lift and rapidly flip over backward which could cause serious injury.

## ENERGY CONSERVATION FOLLOW THESE RECOMMENDATIONS



**An Energy Conservation Plan is your best insurance against waste. Energy is Money. Don't Waste It!!**

An Energy Conservation Plan consists of:

1. Being sure the equipment is properly adjusted to the task being performed. Review Operator's Manual thoroughly.
2. Being sure the operator is thoroughly trained in the operation of the equipment. Review Operator's Manual thoroughly.
3. Being sure that proper lubrication and maintenance procedures are followed. Review Operator's Manual thoroughly.
4. Matching as closely as possible the tractor size (horsepower) to the implement size and soil conditions.

The following additional recommendations are made by Product and Test Engineers to assist you in operating your equipment at maximum efficiency. To do so will allow you to get the most out of your dollars spent on energy.

5. Make sure the engine is properly adjusted. This includes:
  - Proper carburetor adjustment.
  - Fuel and air filter servicing at the proper intervals.
  - Check air gap of the ignition points and spark plugs.
6. Use the proper lubricants and fuel for the particular season of the year the tractor is being operated.
7. Do not overfill the fuel tank.
8. Do not idle the engine for long periods of time.
9. Make sure the tires are inflated properly. Refer to "Tires" for various inflation pressures.
10. Many tractor operations do not require full load operation. Whenever possible shift to a higher gear and throttle back to increase fuel economy.
11. Make the minimum number of passes over the field.
12. Maintain sharp mower blades.
13. Level the mower properly.
14. Keep the underside of the mower deck clean.

# INSTRUMENTS AND CONTROLS

Your lawn tractor has been safety engineered. Thoroughly acquaint yourself with all the controls before attempting to start or operate the lawn tractor.

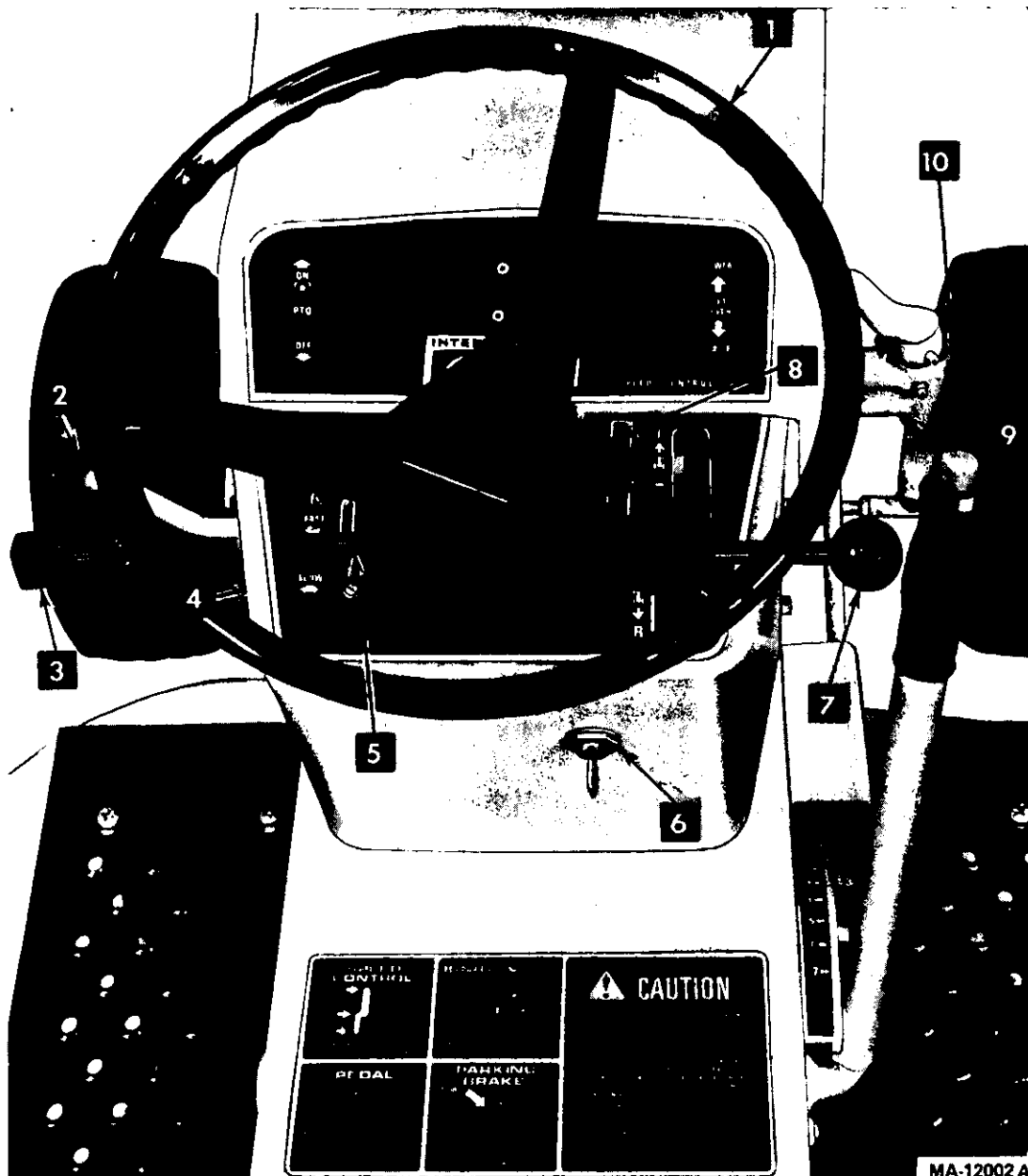

1. Steering wheel
2. Mower clutch lever
3. Clutch brake pedal
4. Clutch brake pedal lock (not seen)
5. Choke and throttle control

6. Ignition switch
7. Speed control lever
8. Speed control stop
9. Lift handle
10. Lift handle release button

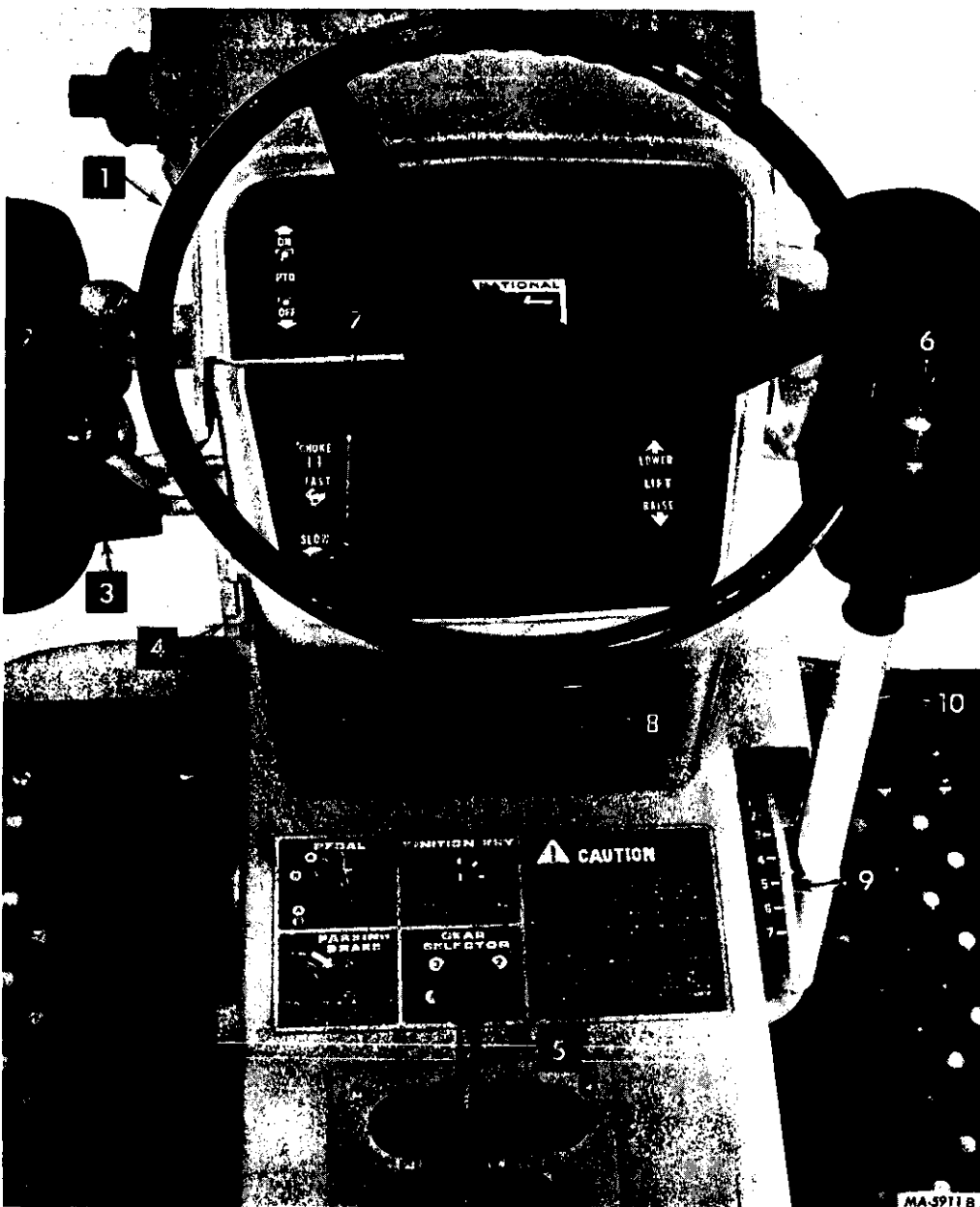

- |   |  |
|---|--|
| <ul style="list-style-type: none"> <li>1. Steering wheel</li> <li>2. Mower clutch control lever</li> <li>3. Clutch-brake pedal</li> <li>4. Clutch-brake pedal lock</li> <li>5. Gear selector lever</li> </ul> | <ul style="list-style-type: none"> <li>6. Lift handle release button</li> <li>7. Choke and throttle control</li> <li>8. Ignition switch</li> <li>9. Lift handle quadrant</li> <li>10. Lift handle</li> </ul> |
|---|--|

Instrument and controls on the Cadet 182 and 382 Lawn Tractors.



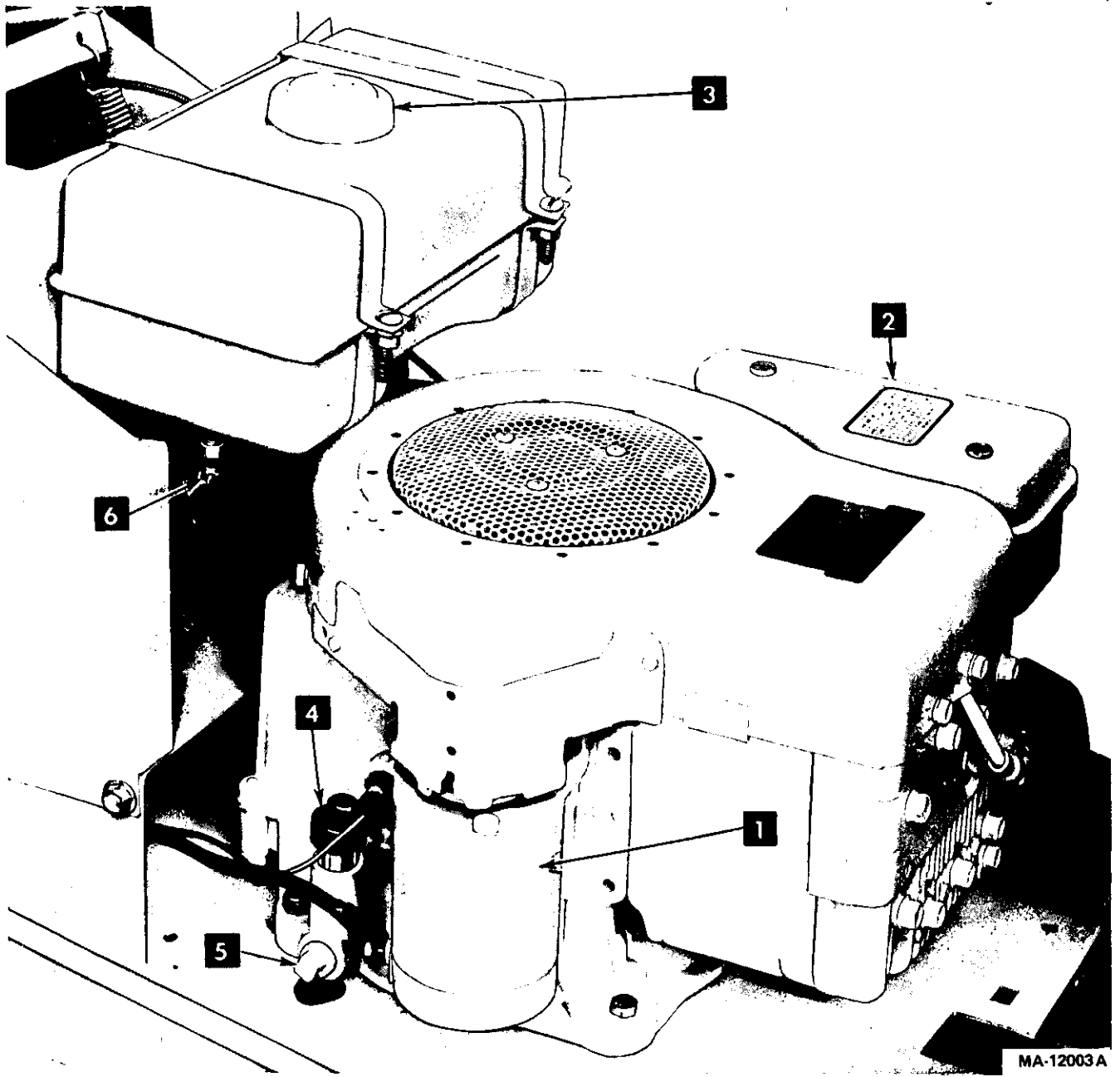

MA-12003A

- 1. Starter
- 2. Air cleaner
- 3. Fuel tank filler cap

- 4. Oil gauge and filler tube
- 5. Oil drain plug
- 6. Fuel line shut-off

**NOTE:**

The tractor hood is arranged to swing up and forward in order to make the engine, fuel tank, air cleaner, etc. readily accessible.

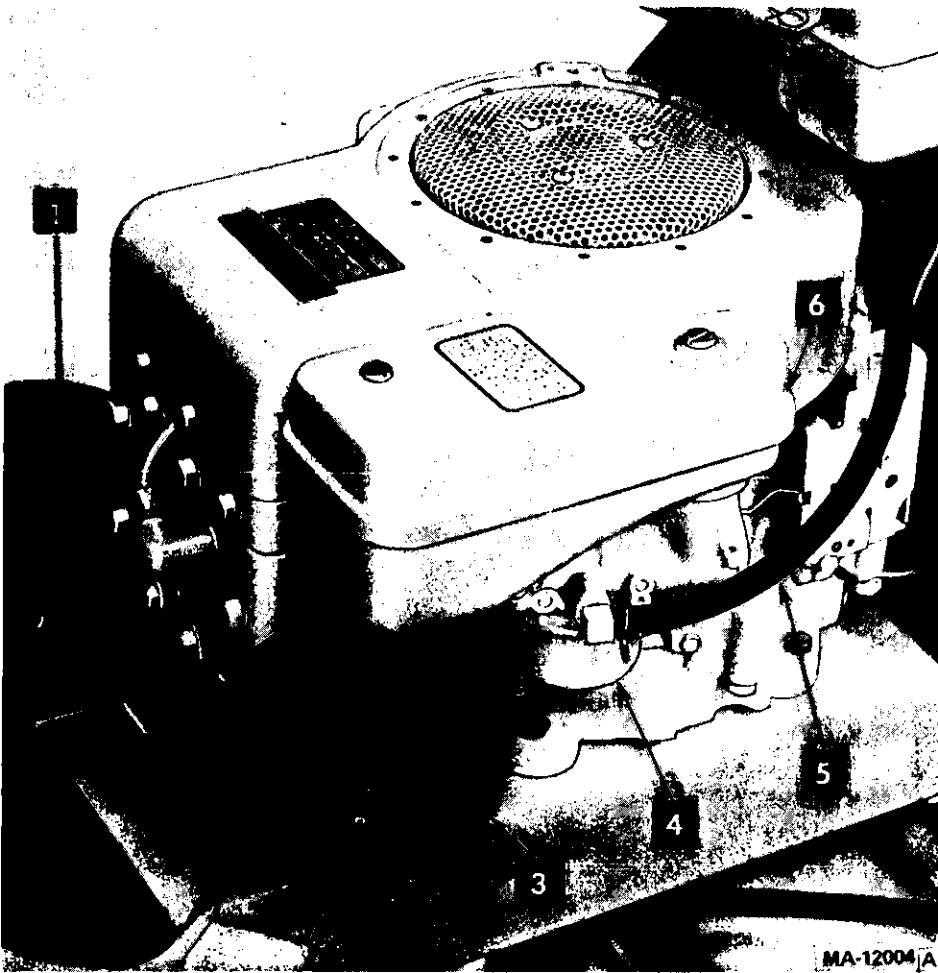

**Model 182 and 282H Tractor**

- 1. High tension wire**
- 2. Spark plug**
- 3. Muffler**

- 4. Carburetor**
- 5. Fuel line**
- 6. Air cleaner**

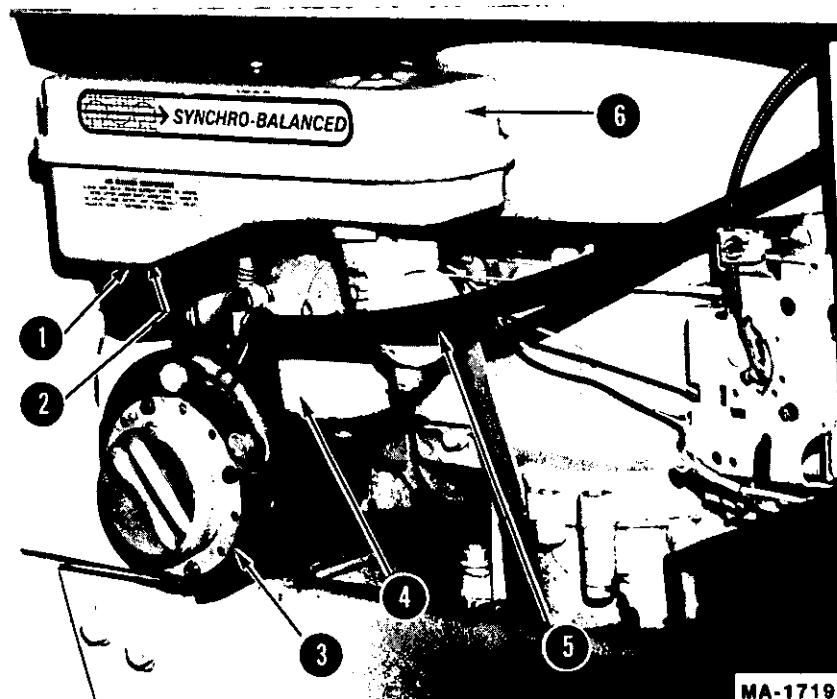

#### Model 382 and 382H Tractor

- |                                 |                |
|---------------------------------|----------------|
| 1. High tension wire (not seen) | 4. Carburetor  |
| 2. Spark plug (not seen)        | 5. Fuel line   |
| 3. Muffler                      | 6. Air cleaner |

## BEFORE OPERATING THE ENGINE

**Lubrication:** See Lubrication Instructions.

**Crankcase:** Check the oil level.

**Fuel System:** This engine is designed to operate on leaded gasoline with a 93 minimum octane rating or on unleaded gasoline with a 91 minimum octane rating (Research Method).

The use of unleaded gasoline will lengthen spark plug and valve life, maintain engine performance longer, and reduce rust and corrosion of engine while stored.

# OPERATING THE ENGINE



## CAUTION

1. Keep all shields in place.
2. Before leaving operator's position:
  - a. Shift transmission to neutral
  - b. Set parking brake
  - c. Disengage attachment clutch
  - d. Shut off engine
  - e. Remove ignition key
3. Wait for all movement to stop before servicing machine.
4. Keep people and pets a safe distance away from machine.
5. Look to the rear before backing up.



## DANGER

**DO NOT OPERATE  
MOWER UNLESS  
GUARD OR ENTIRE  
GRASS CATCHER IS  
IN ITS PROPER PLACE.**



## WARNING

### STARTING THE ENGINE

#### NOTE:

The lawn tractor has an interlock safety starting system and the engine will not start unless the following steps have been taken:



## WARNING

Do not operate the tractor if the interlock system is malfunctioning because it is a safety device, designed for protection.

Be sure the spark plug wire is properly attached to the spark plug.

Make certain the mower clutch control lever is in the "DISENGAGED" position.

Be sure the speed control lever (hydrostatic models) or the gear selector lever (gear driven models) is in "NEUTRAL."

#### NOTE:

The speed control lever will not return to neutral when the clutch-brake pedal is depressed.

The clutch-brake pedal must be depressed all the way down and the mower clutch lever must be in the disengaged position to actuate the safety starting switch.

Move the choke and throttle control lever to the "CHOKE" position when engine is cold. Little or no choking is required when engine is warm.

Turn ignition key clockwise to the start position and release it as soon as the engine starts. Do not operate the starter more than 30 seconds at any one time. If engine does not start within this time, turn the key off and wait a few minutes, then try again.

After engine starts, slowly move the choke and throttle lever to the "FAST" position.

### CLUTCH-BRAKE PEDAL

**Hydrostatic Models**—The combination clutch-brake pedal is used to disengage the engine from the hydrostatic drive and to actuate the brake to stop the tractor.

To disengage the clutch and apply the brake, press the pedal all the way down.

**Gear Drive Models**—The combination clutch-brake pedal is used to disengage the engine from the transmission when shifting gears and to actuate the brake to stop the tractor.

To shift gears while tractor is in motion, pedal should be depressed approximately ½ the travel distance.

To disengage the clutch and apply the brake, press the pedal all the way down.

### STOPPING THE ENGINE

**Hydrostatic Models**—Set the speed control lever in "NEUTRAL" and set the mower clutch lever in the "OFF" position to disengage the mower. Allow the engine to idle a few minutes before turning ignition key to the "OFF" position.

**Gear Drive Models**—Depress the clutch-brake pedal to disengage the transmission and set the gear selector lever in "NEUTRAL." Set the mower clutch lever in the "OFF" position to disengage the mower. Allow the engine to idle a few minutes before turning ignition key to the "OFF" position.

# DRIVING THE LAWN TRACTOR



## WARNING

Never direct discharge of material toward by-standers nor allow anyone near the machine while in operation.

## IMPORTANT:

If you strike a foreign object, stop the engine. Remove wire from spark plug and keep the wire away from the plug. Thoroughly inspect the mower for any damage, and repair the damage before restarting and operating the mower.

## Break-In Procedure

To obtain the best service from the lawn tractor, for the first few hours of operation avoid rapid engagement of the mower clutch and main drive clutch.

After starting the engine:

Set the throttle control on "FAST."

If the clutch-brake pedal is in the locked position, release the lock.

Engage the mower blades by moving the mower clutch control lever SLOWLY forward to the "ON" position. To stop the mower pull the lever back to the "OFF" position.

Set lift handle at the desired cutting height.

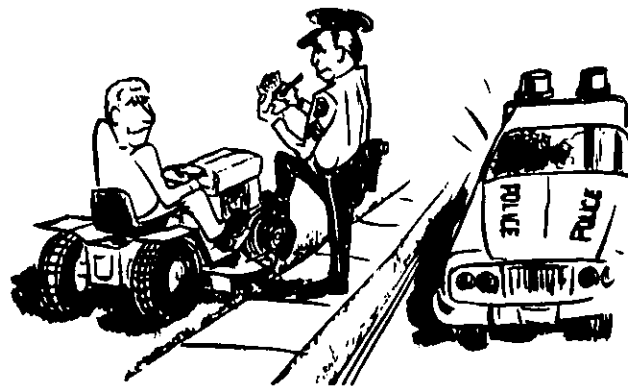

## WARNING

Clear work area of objects which might be picked up and thrown.

**Hydrostatic Models**—To start the lawn tractor in motion move the speed control lever forward to obtain the proper speed to control the machine, and to obtain an even cut. As conditions vary, this can best be determined after you become familiar with the lawn, climate, and individual preference, etc.

An adjustable speed control stop is provided to allow the operator to return to a predetermined speed. The speed control lever can bypass the speed control stop by pushing the lever outward and sliding it past the stop.

## NOTE:

It is recommended that to start the tractor in motion and to change speed and direction, use ONLY the speed control handle. The clutch-brake pedal can be used to stop the machine, but machine operates more effectively by engaging the clutch with the speed control in neutral and then move the speed control handle to put the machine in motion.





## WARNING

To prevent injury, do not carry passengers or give rides. Keep children, pets, and by-standers a safe distance away.

**Gear Drive Models**—Disengage transmission and set the gear selector lever at the speed necessary to obtain an even cut. As conditions vary, this can best be determined after you become familiar with the tractor, type of grass, condition of lawn, climate, individual preference, etc.

Start the tractor in motion by **SLOWLY** releasing the clutch pedal.



## WARNING

Until you have the feel of your lawn tractor, go slowly at first, avoid sharp turns at high speed, and on steep slopes to avoid an upset or loss of control.

## RELEASE LEVER (Hydrostatic Models)

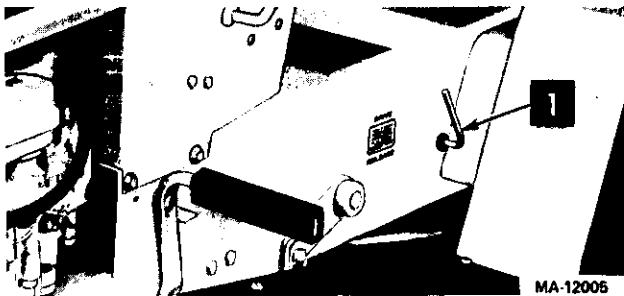

### 1. Release lever

To push or move the tractor for a short distance, the release lever must be held in the down position and the speed control lever must be in the "NEUTRAL" position.



## WARNING

Never operate engine with release lever in (down) position. Towing or pushing the tractor for more than a few feet may result in transmission damage.

## LOCKING THE BRAKE

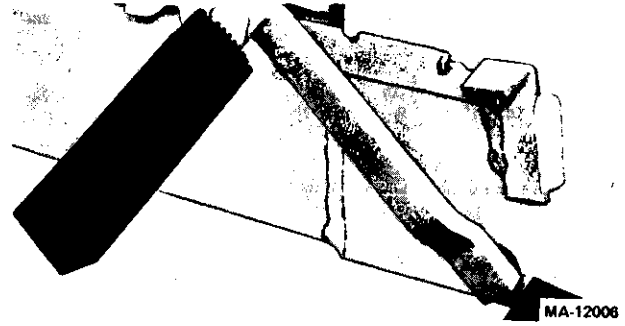

Always lock the parking brake when the tractor is parked on a grade. To lock the brake, press down on the clutch-brake pedal and place the clutch-brake pedal in engaged position, as shown. To disengage the lock press down on the pedal, push the lock down and place it in the disengaged position.



## WARNING

To prevent an accident, always disengage the mower, set the speed control lever in neutral position, set the parking brake, stop the engine, and remove the ignition key when leaving the machine unattended.

## ADJUSTING AND OPERATING

### ADJUSTING THE SEAT

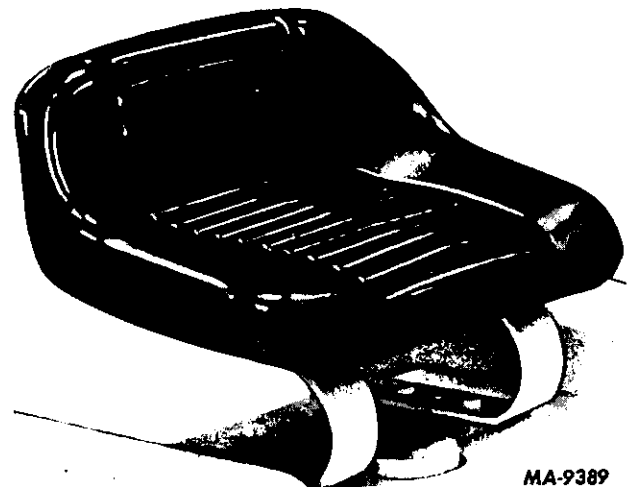

Before starting the tractor, adjust the seat to the most comfortable driving position. To adjust the seat loosen the four bolts holding the seat to the tractor frame and slide the seat forward or back to the desired position.

If further forward adjustment is desired, remove the four bolts holding the seat to the springs and reposition in the four forward holes provided.

**NOTE:**

The seat assembly bolts must be tightened to 20 ft. lbs. Periodically check the bolts for proper tightness.

**CLEANING THE MOWER**

Clean the underside of the mower at the end of the mowing season and when the build-up of cut material on the underside is noticed.



**WARNING**

To prevent an accident or possible injury, always stop the engine and disconnect the spark plug wire, lock the brake, place mower clutch control lever in the disengaged position prior to cleaning or doing any work on the mower.

**HEIGHT OF CUT**

Cutting height can be adjusted from approximately 1½-inches to 4¼-inches quickly and easily. Depress the release button on top of the lift handle to set the handle in the desired notch of the lift handle quadrant. The quadrant is marked for ease in selecting the desired height of cut. The height of cut is approximate since operator weight and tire inflation will effect the cutting height.

The mower extends beyond the driving wheels to permit cutting close to walkways, fences, buildings, trees, etc.

**BLADE CARE**

The cutting blades are designed to create a suction to lift the grass for an even cut.

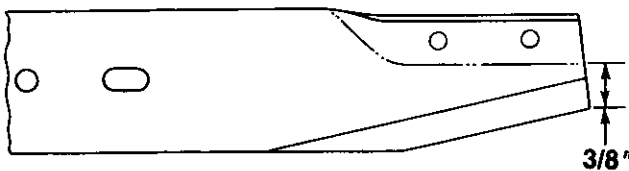

The cutting blades must be kept sharp at all times. The blades can be sharpened on the mower with a few strokes of a file or they can be removed from the mower and sharpened on a grinding wheel.



**WARNING**

Be careful not to cut yourself when sharpening the blades or cleaning the underside of the mower.

Cutting edge should be kept at production angle (25 degrees) with bottom of blade to insure maximum cutting efficiency of blades.

**NOTE:**

Sharpen ends evenly so that blades remain balanced. However, if the cutting edge of the blade is within 3/8-inch of the wind wing, it is recommended that new blades be installed. New blades are available at your authorized dealer.

Be sure blades are assembled so the cutting edges are in the direction of rotation with the wind wings pointed toward the deck.

To detach the blade, place a large wood block between the cutting edge and housing to keep the blade from rotating. Then remove the hex head capscrews, nuts and washers.

When replacing blades use the reverse procedure, except put the wood block between the wing of the blade and the deck.

**ADJUSTING THE BRAKES**

With the brake pedal in the up position (10 degrees from vertical) and all slack taken out of the linkage, adjust brake adjusting nut to allow 5/16 to 3/8-inch clearance between nut and arm. See pages 18 and 21.

**SEAT SAFETY SWITCH**

When using power take-off operated equipment, the operator must remain in tractor seat at all times. If operator should leave tractor seat without turning off the power take-off switch, the engine will automatically shut off.

**ATTACHING AND DETACHING THE MOWER**

To facilitate changing the blades, sharpening the blades, cleaning, etc., the mower may be detached as follows:

Place the mower clutch control lever in the "OFF" position. Stop the engine and disconnect the spark plug wire.

1. Disconnect the mower drive belt from the main drive pulley and clutching idler pulley. The belt guide around the main drive pulley is spring hooked for ease in removing the belt.
2. Position the mower in the lowest position.

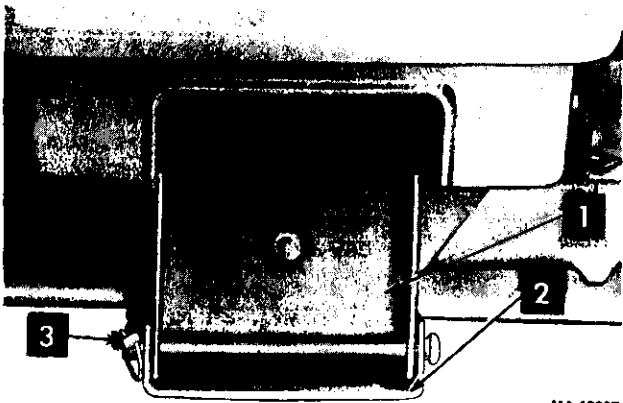

MA-12007

1. Front mower hanger bracket
2. Front mower leveling link
3. Klik pin

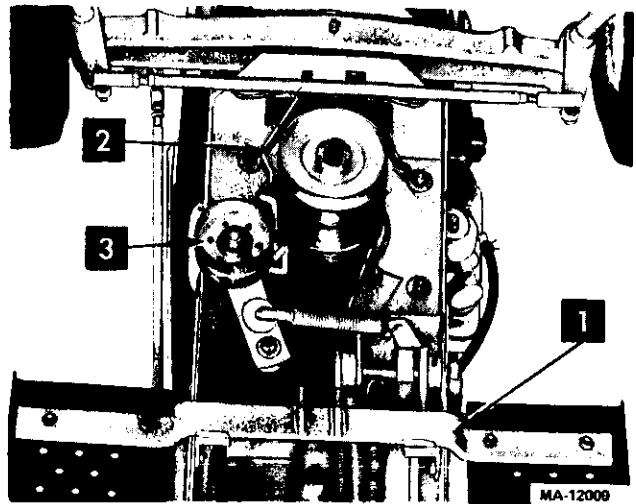

MA-12009

1. Front foot rest support bracket
2. Main drive pulley and belt guide
3. Mower drive belt idler

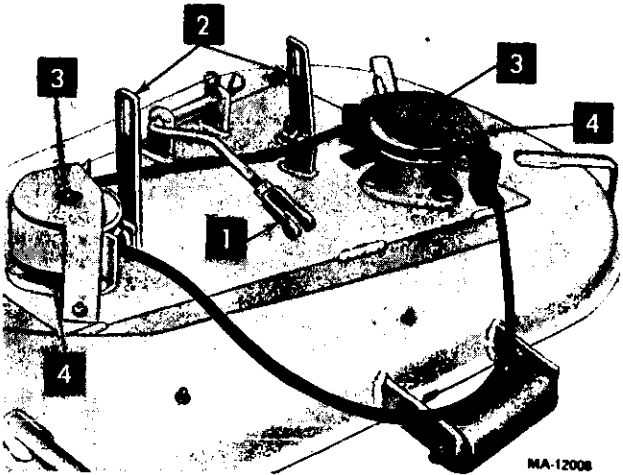

MA-12008

1. Mower linkage rod and clevis
2. Lift links
3. Lubrication fittings
4. Belt guides

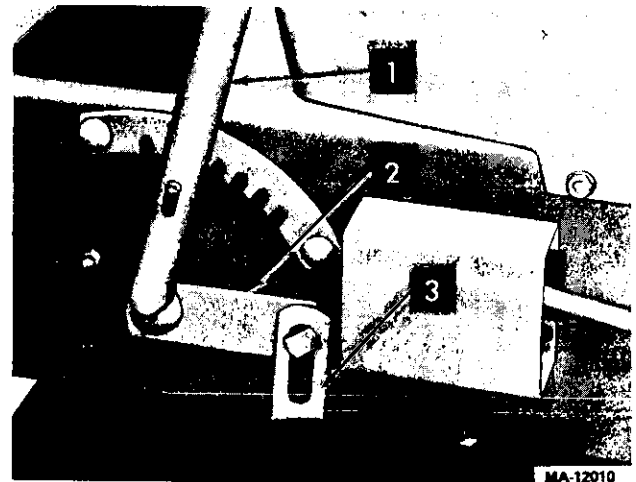

MA-12010

1. Lift handle
2. Lift arm
3. Lift link (one on each side)

To attach the mower to the lawn tractor, reverse the above procedure.

3. Disconnect the mower linkage rod from the front foot rest support bracket by removing the quick attachable pin and rod pin through the clevis.
4. Detach the front mower leveling link from the front hanger bracket and the front of the mower by removing the pins which are held by klik pins.
5. Raise the mower by hand, first on one side and then the other, to disconnect the mower lift links from the mower.

### LEVELING THE MOWER

A properly leveled mower is one where the blades are cutting parallel to the ground. Should level adjustment be necessary due to tire variation or wear, proceed as follows:



### WARNING

To avoid possible injury, stop the engine, disconnect the high tension wire to the spark plug, and lock the brake prior to leveling the mower.



### Leveling the Mower From Front to Rear

Drive the lawn tractor onto a hard flat surface.

Turn the ignition off and disconnect the high tension wire to the spark plug. Lock the tractor brake.

Measure the distance from the ground to the blades (blades parallel to centerline of tractor) front and rear in typical cutting height.

Adjust the clevis on the end of the mower linkage rod either up or down, depending on which measures high.

### Leveling the Mower From Side to Side

The left lift link is adjustable should the mower require side to side adjustment. Turn the adjusting bolt up or down depending on which side measures too high.

## MOWER DRIVE V-BELT



### WARNING

To avoid an accident or possible injury, always stop the engine, disconnect the high tension wire to the spark plug, and lock the brake before doing any work on the machine.

The mower drive belt requires no adjusting, as proper belt tension is maintained by the spring loaded mower drive belt idler.

When the belt has worn or stretched to a point where slippage occurs, a new belt should be installed.



### WARNING

To avoid an accident or possible injury, always stop the engine, disconnect the high tension wire to the spark plug, and lock the brake before doing any work on the machine.

### NOTE:

Substitute belts may not be satisfactory. Use only specified replacements. See your authorized dealer.

Refer to the instructions for attaching and detaching the mower.

Both belt guides must be removed from the mower housing in order to replace the belt.

After replacing the belt and two belt guides, check and make sure the belt guides do not rub against the mower pulleys.

### NOTE:

When installing a new belt, make certain that the belt runs correctly between the pulleys and the belt guides.

## CRANKSHAFT MAIN DRIVE AND HYDROSTATIC FINAL DRIVE BELTS—HYDROSTATIC MODELS

The drive belts are set at the factory and require no adjustment. When the belts have worn or stretched to a point where slippage occurs in forward or reverse, new belts should be installed.

Set the mower clutch lever in the "OFF" position, set the speed control lever in "NEUTRAL," and lock the parking brake.

Disconnect high tension wire to the spark plug.

Detach the mower. Refer to Attaching and Detaching instructions.

Disconnect the spring loaded mower drive belt idler from the mower clutch arm in order to reach the crankshaft drive belt idler and also in order to remove the hydrostatic final drive belt.

To disconnect the spring, pull the mower drive idler to the right of the tractor and insert a coin (a Quarter is recommended) between two coils of the spring.

Push up on the hydrostatic final drive belt idler pulley in order to remove the hydrostatic belt. Belt must be removed from the intermediate pulley first. It may also be necessary to turn the engine crankshaft by hand in order to slip the belt over the intermediate pulley.

After removing the hydrostatic belt, remove the crankshaft main drive belt.

When installing new belts reverse the above procedure.

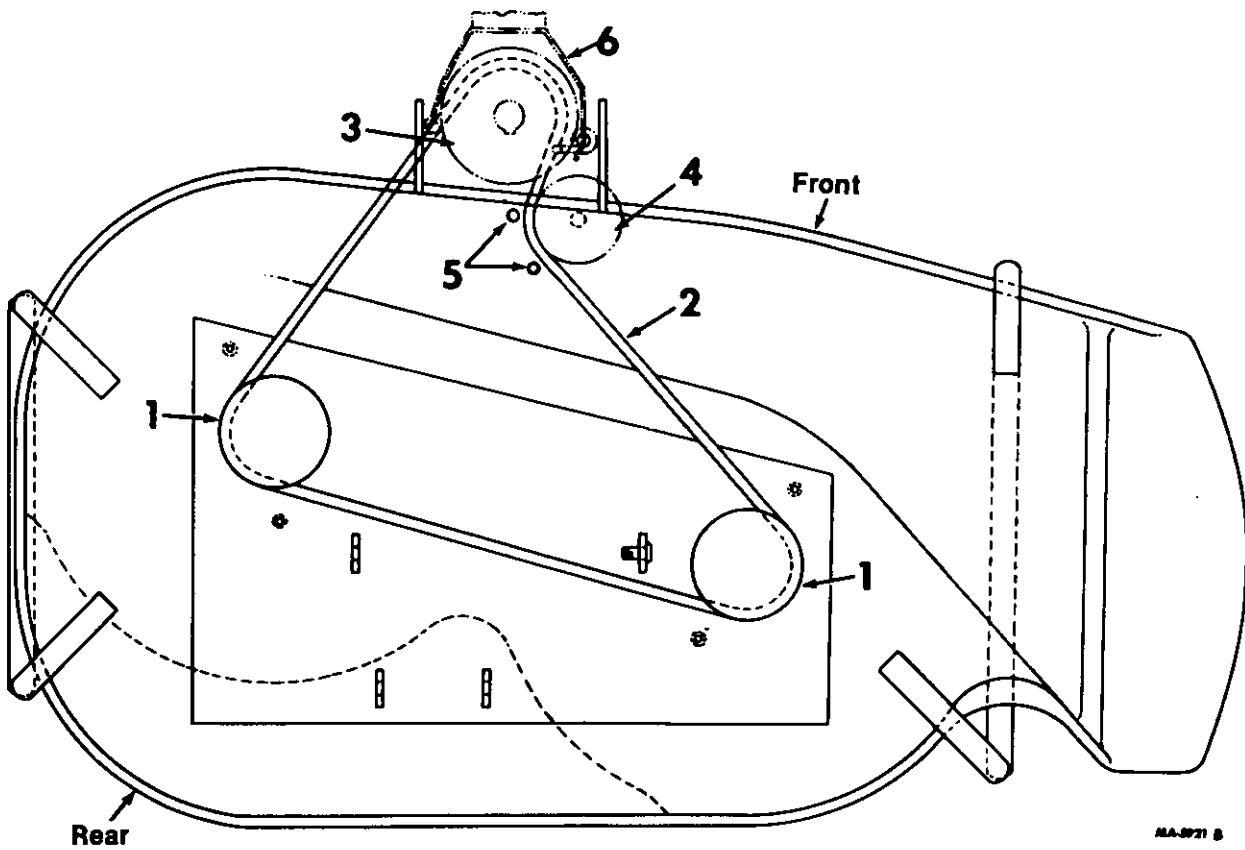

- 1. Mower blade spindles
- 2. Mower drive belt
- 3. Mower drive pulley

- 4. Mower drive belt pulley idler
- 5. Belt guides
- 6. Belt guide

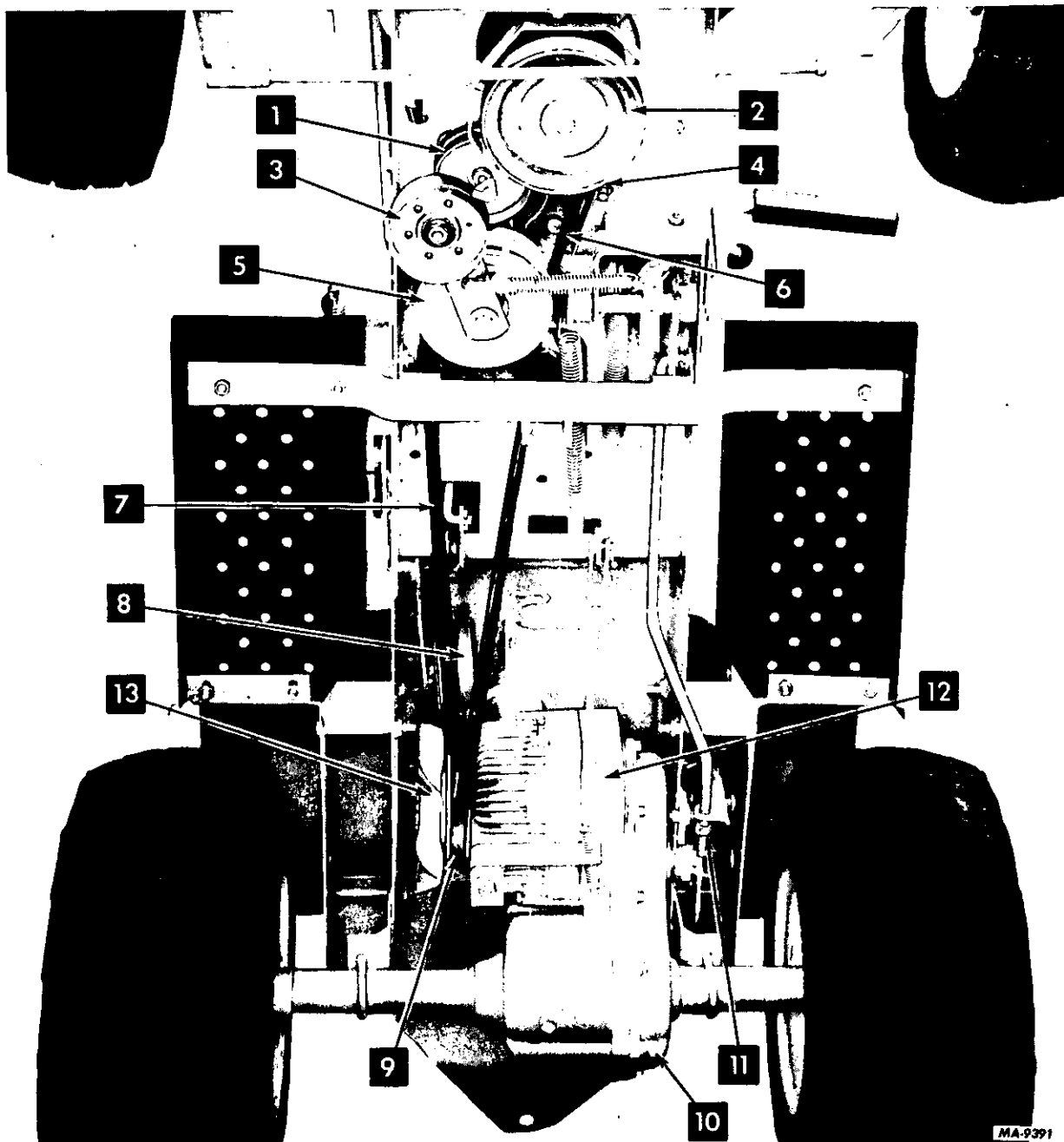

- 1. Crankshaft main drive belt idler
- 2. Mower drive pulley
- 3. Mower drive belt idler
- 4. Crankshaft main drive pulley (Not seen—behind mower drive pulley.)
- 5. Intermediate drive pulley
- 6. Crankshaft main drive belt

- 7. Hydrostatic final drive belt
- 8. Hydrostatic belt idler pulley
- 9. Hydrostatic pulley
- 10. Gear reduction unit
- 11. Brake adjusting nut
- 12. Hydrostatic unit
- 13. Hydrostatic fan

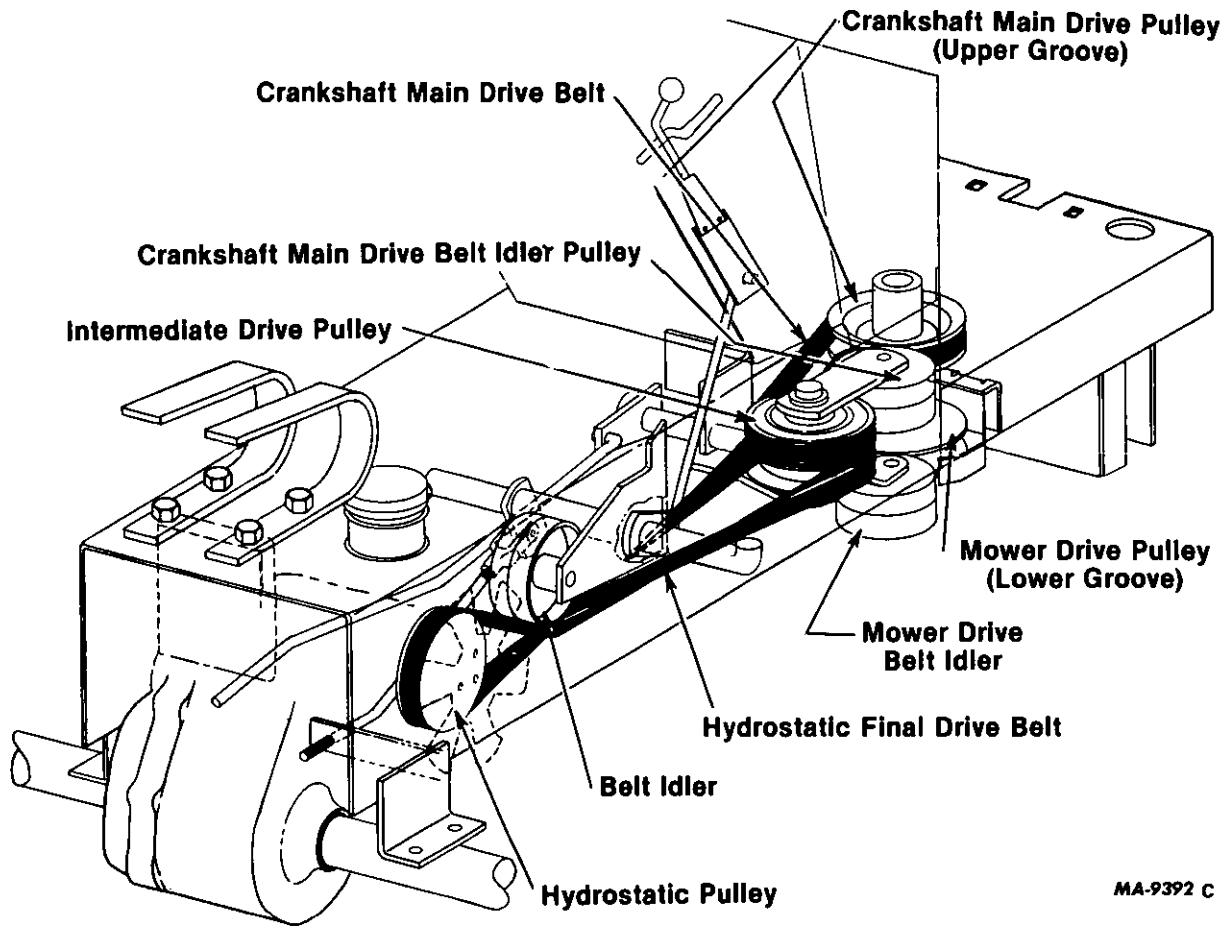

**Belt installation diagram.  
 Top and side view of tractor.**

## CRANKSHAFT, MAIN DRIVE, AND FINAL DRIVE BELTS—GEAR DRIVE MODELS

The main drive belts are set at the factory and require no adjustment. When the belts have worn or stretched to a point where slippage occurs in forward or reverse, new belts should be installed.



### WARNING

Always disconnect the high tension wire to the spark plug before making any adjustments to your lawn tractor or to the mower.

Set the mower clutch control lever in the "OFF" position, set the transmission gear selector lever in "NEUTRAL," and lock the parking brake.

Detach the mower. Refer to Attaching and Detaching Instructions.

Disconnect the spring loaded mower drive belt idler from the mower clutch arm in order to reach the crankshaft drive belt idler and also in order to remove the transaxle belt.

To disconnect the spring, pull the mower drive idler to the right of the tractor and insert a coin (a Quarter is recommended) between two coils of the spring.

Push up on the transaxle belt idler pulley in order to remove the transaxle final drive belt.

After removing the transaxle belt, remove the crankshaft main drive belt.

When installing new belts reverse the above procedure.

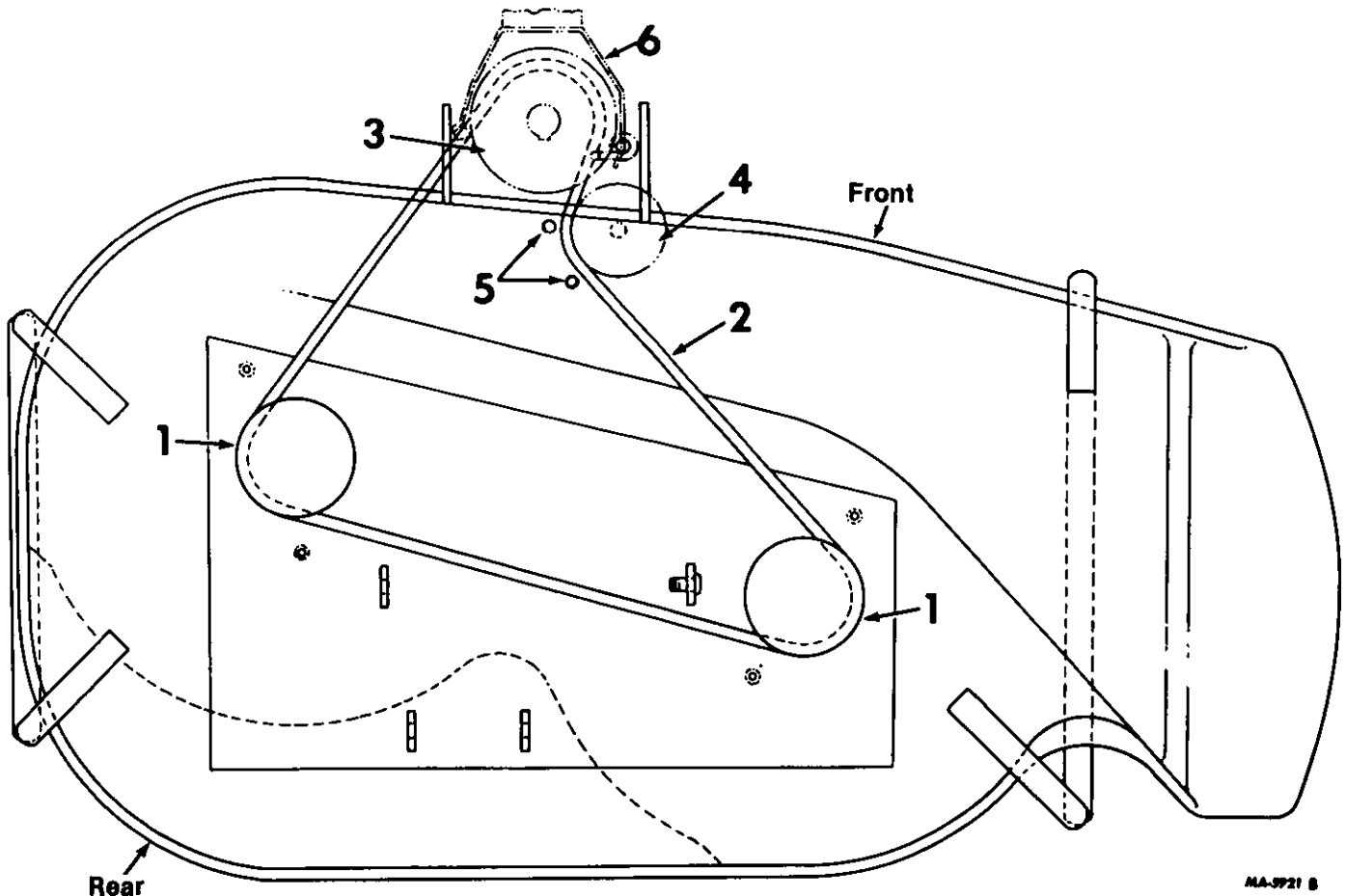

1. Mower blade spindles
2. Mower drive belt
3. Mower drive pulley

4. Mower drive belt idler
5. Belt guide
6. Mower drive pulley belt guide

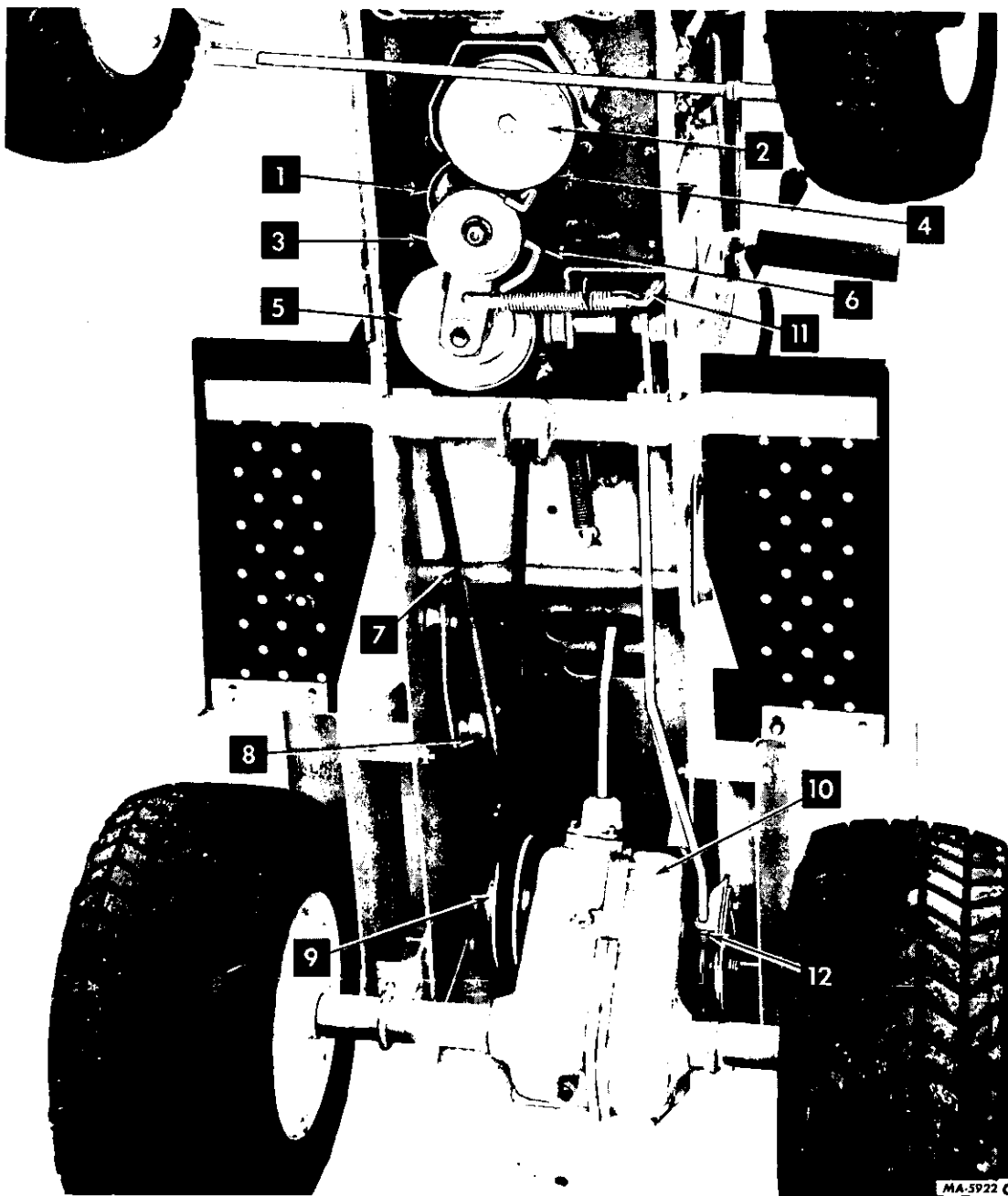

1. Crankshaft main drive belt idler pulley
2. Mower drive pulley
3. Mower drive belt idler
4. Crankshaft main drive pulley (Not seen—behind mower drive pulley.)
5. Intermediate pulley
6. Crankshaft main drive belt

7. Transaxle final drive belt
8. Transaxle belt idler pulley
9. Transaxle pulley
10. Transaxle
11. Mower clutch arm
12. Brake adjusting nut

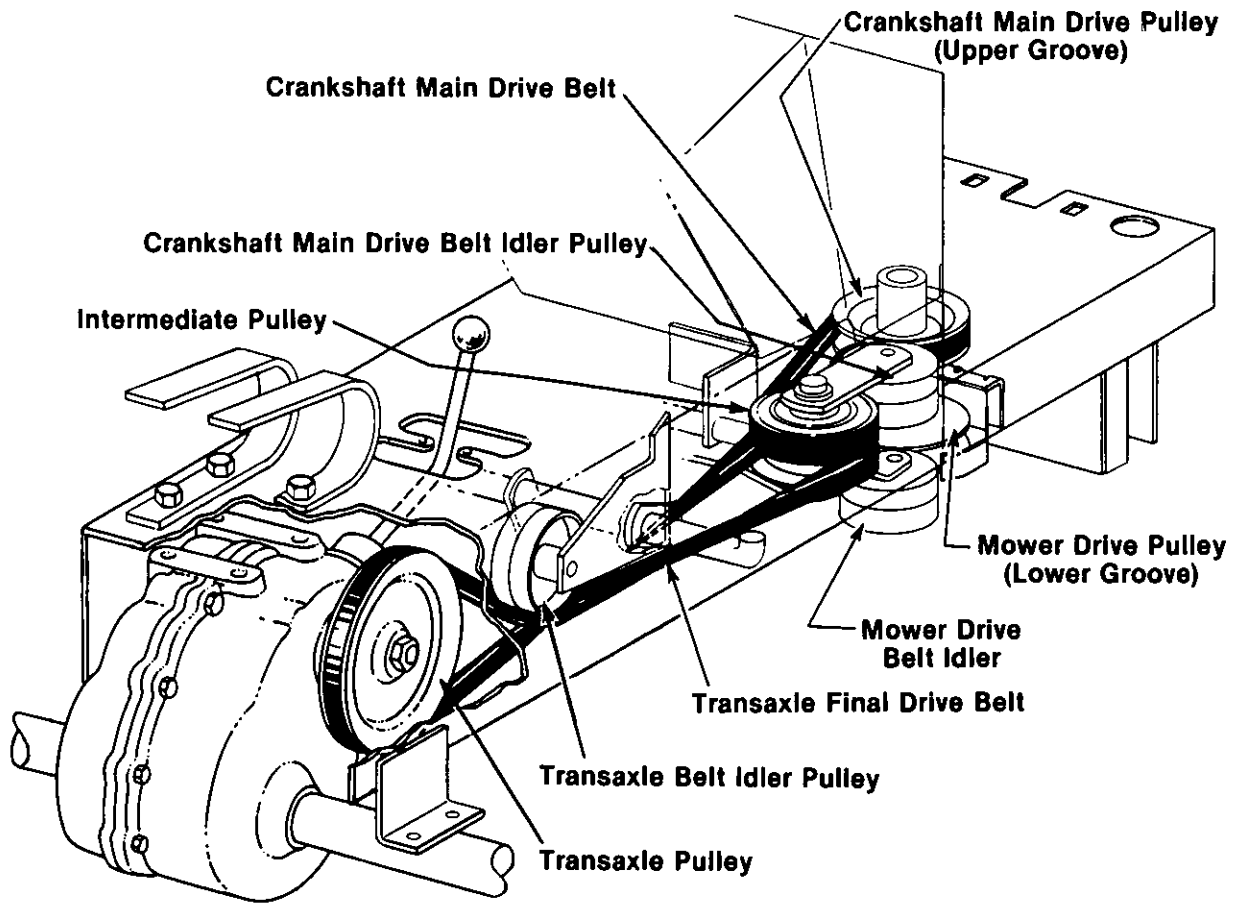

**Belt installation diagram.  
Top and side view of tractor.**



## CAUTION

Read the Operator's Manual  
Learn to operate this machine SAFELY  
Be alert. Observe ALL Safety Practices  
Machines can be hazardous in the hands of an  
UNFAMILIAR, UNTRAINED or COMPLACENT  
operator.  
Don't risk INJURY or DEATH.

HA10034

# FUEL SYSTEM



## WARNING

To avoid injury or an accident, be sure the brake pedal is in the locked position, transmission is in neutral, and any equipment is disengaged before adjusting the carburetor. Keep clear of all moving parts. Be careful of heated surfaces and muffler.

## CARBURETOR ADJUSTMENTS



## WARNING

To avoid injury or an accident, be sure the brake pedal is in the locked position, transmission is in neutral, and the mower is disengaged before adjusting the carburetor.

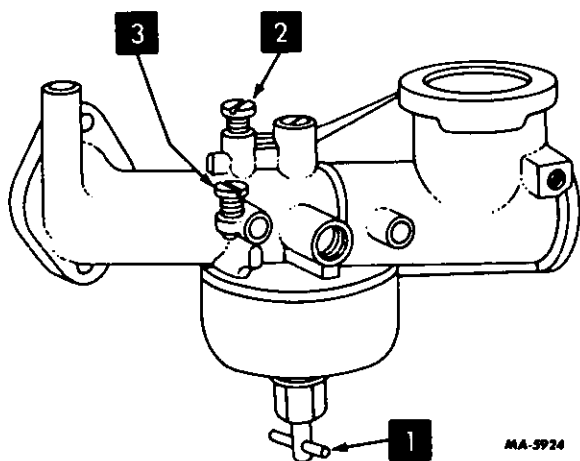

1. Needle valve
2. Idle valve
3. Idle speed adjusting screw

The carburetor is adjusted at the factory. Do not make adjustments unless absolutely necessary. Factory settings are correct for normal operating conditions. If adjustments are necessary, proceed as follows:

Start the engine and allow it to warm up at 3000 RPM. Turn needle valve in until engine misses (lean mixture) then turn it out past smooth operating point until engine runs unevenly (rich mixture). Turn needle valve to the mid-point between rich and lean so engine runs smoothly.

Hold throttle at idle position and set idle speed, adjusting screw until engine idle speed is 1800 RPM. Hold throttle at idle position and turn idle valve in (lean) and out (rich) until engine idles smoothly. If necessary, correct idle speed. Release the throttle—engine should accelerate without hesitation or sputtering. If engine does not accelerate properly, the carburetor should be readjusted, usually to a slightly richer mixture of needle valve.

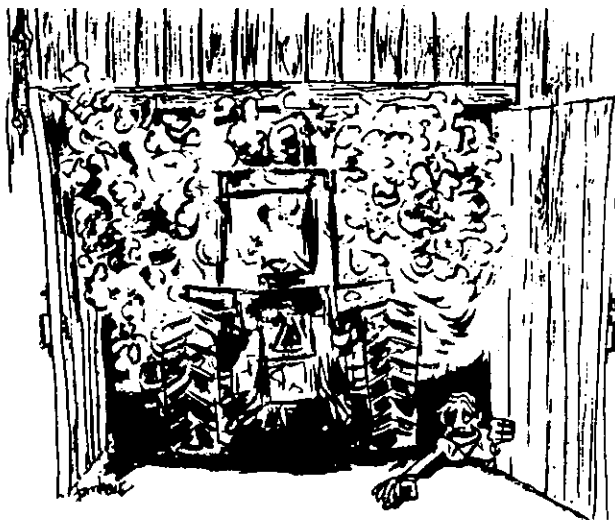

## WARNING

EXHAUST FUMES CAN KILL. Never operate vehicle in an enclosed area.

## Recommended Fuel

This engine is designed to operate on leaded gasoline with a 93 minimum octane rating or on unleaded gasoline with a 91 minimum octane rating (Research Method).

The use of unleaded gasoline will lengthen spark plug and valve life, maintain engine performance longer, and reduce rust and corrosion of engine while stored.



## WARNING

Handle gasoline with care, as it is highly flammable. A. Use approved gasoline container. B. Never remove the fuel tank cap or fill tank when the engine is running, is hot, or indoors. Also, do not smoke when working around flammable fuel. Wipe up spilled gasoline. C. Replace fuel tank cap securely.



# ELECTRICAL SYSTEM

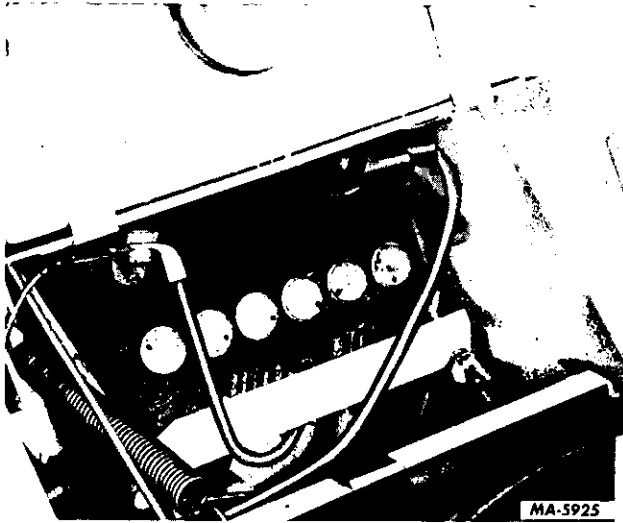

The battery is located under the hood and in back of the fuel tank, for electric starting models.

The charging circuit built into the engine provides a charging circuit output from 2 amperes at 2400 RPM to 3 amperes at 3600 RPM and uses less than .2 horsepower.

Check the battery level at least once a month. Keeping the battery fully charged not only adds to its life but makes it available for instant use when needed.

The electrolyte (acid and water) in each cell should be at ring level at all times to prevent battery failure. When the electrolyte is below this level, add pure, distilled water.



## WARNING

Electrical storage batteries give off highly inflammable hydrogen gas when charging and continue to do so for some time after receiving a steady charge. Do not under any circumstances allow an electric spark or an open flame near the battery. Do not lay tools across battery terminals as this may result in a spark or short circuit which may cause an explosion. Be careful to avoid spilling any electrolyte on hands or clothing.



## WARNING

Acid or electrolyte should never be added except by a skilled battery man. Under no circumstances add any special battery "dopes," solutions, or powders.

Occasionally remove the battery cables and brighten the terminal contact surfaces with wire wool, and reassemble. Apply a light coat of vaseline or chassis lubricant. Be sure terminals are clamped tightly, the rubber cover is slid over the positive terminal, and that battery is fastened securely in the battery box. Replace defective cable, and keep vent holes in battery filler caps open.



## WARNING

When removing the battery cables, remove the white cable (ground) first and then the red cable from the positive side of the battery. Otherwise, sparks may result causing an accident. When reattaching or reinstalling the battery reverse the above procedure. Also, be sure battery connections do not make contact with tractor frame.

## SPARK PLUG

### NOTE:

Remove all dirt from base of spark plug before removing.

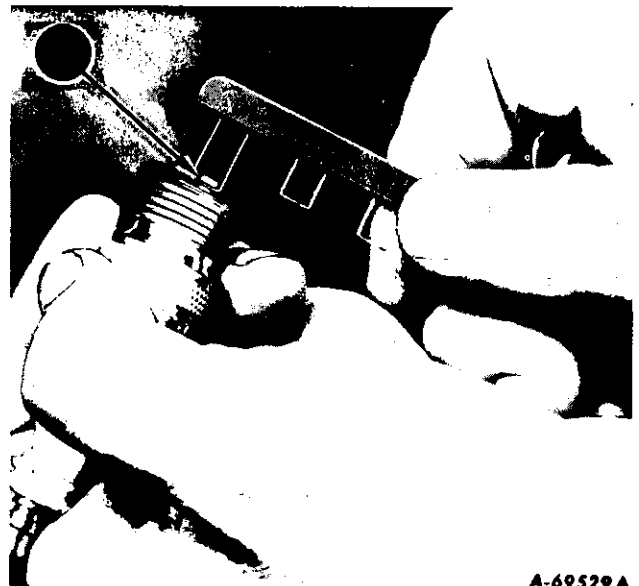

A-69529A

Checking the spark plug gap.  
Set gap at .030-inch.

Remove the spark plug after every 100 hours of operation for cleaning and checking the gap. When adjusting the gap, always bend the outer electrode. Never bend the insulator. If gap between the electrodes is too great, the engine will misfire and be hard to start.

Always use a spark plug wrench when removing or reinstalling the plug.

Be sure the gasket is in good condition, and screw plug in tightly. Do not tighten more than enough to compress the gasket to seal the plug and assure a good heat transfer between the plug and cylinder head.

Replace defective plug with new plug. See your authorized dealer for a correct replacement plug.

### Cleaning Spark Plug

Clean spark plug with a pen knife or wire brush and solvent. If electrode is burned away or the porcelain is cracked, replace with new plug.

### NOTE:

Do not use abrasive cleaning machine; because any grit introduced into the engine could cause severe damage.

## ENGINE COOLING AND AIR CLEANER

### ENGINE COOLING

This is an air-cooled engine. Air must circulate freely around the engine. Keep the cooling fins and housing area free of accumulated dirt and trash or engine will overheat and result in damage to moving parts.

### OIL FOAM AIR CLEANER

Clean and re-oil the air cleaner element every 25 hours under normal operating conditions. Under extremely dusty conditions, clean the element every few hours.

To clean the element, proceed as follows:

Remove the cover screws, lift the air cleaner cover and carefully remove the element to prevent dirt from entering the carburetor.

Wash the foam element in kerosene or liquid detergent and water to remove all dirt. Also clean the air cleaner body and cover.

Wrap the foam element in a cloth and squeeze dry. Then, saturate the element in engine oil (SAE-30). Squeeze the element to remove excess oil and reassemble and fasten to carburetor with screw.

### NOTE:

Replace air cleaner gaskets and mounting gaskets that are worn or damaged, to prevent dirt or dust entering engine through improper sealing.

## STORING THE LAWN TRACTOR

At the end of the mowing season or in the event the lawn tractor is to be stored for any length of time (30 days or more) proceed as follows:

Drain the fuel tank and run the engine until the fuel is exhausted from the fuel system.



### WARNING

Drain the fuel tank outside and into a clean container.

Remove spark plug and pour one ounce of I.H. No. 1<sup>®</sup> Engine Oil through spark plug hole into the cylinder. Crank engine several times to distribute oil over cylinder walls. Replace the spark plug.

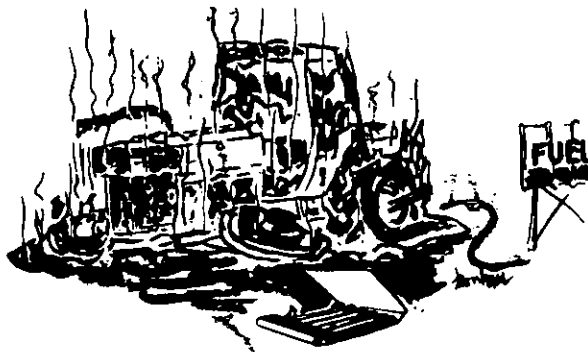

### WARNING

CAUTION! NEVER SMOKE while refueling. Shut off engine and electrical equipment.



### WARNING

Handle gasoline with care, it is highly flammable. A. Use approved gasoline container. B. Never remove the fuel tank cap or fill tank when engine is running, is hot, or indoors. Also, do not smoke when working around flammable fuel. Wipe up spilled gasoline. C. Replace fuel tank cap securely.

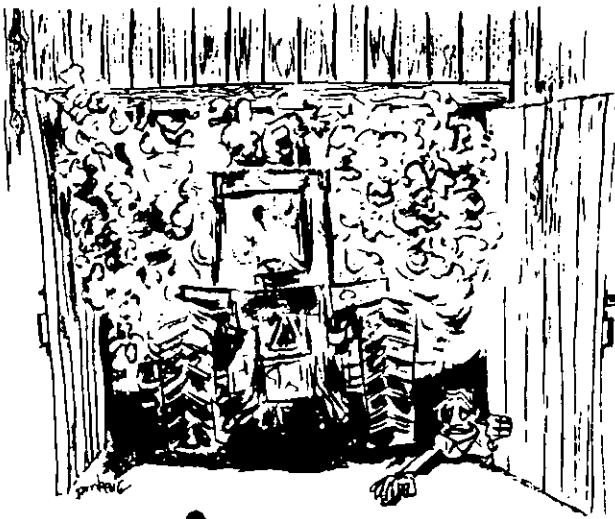

### WARNING

**EXHAUST FUMES CAN KILL.** Never operate vehicle in an enclosed area.



### WARNING

During operation do not run the engine in confined area such as storage building any longer than is necessary for immediate moving of the machine outside into the air. Exhaust gases are toxic. Opening doors and windows may not provide adequate ventilation.

Wash or clean and completely lubricate the lawn tractor. See "Lubrication Guide." This tractor has a fiberglass hood and grille. Use only a mild soap or detergent. Do not use ammonia base or abrasive cleansers.

Remove the battery and place it in a cool, dry place above freezing (+32°F.). Check the battery at least once a month for water level and amount of charge.



### WARNING

To avoid possible injury, when removing battery avoid spilling the electrolyte. Battery electrolyte is poisonous and can be injurious to eyes, skin and clothing. If electrolyte is spilled, flush immediately with a solution of one part baking soda and four parts water.

Store your riding mower in a dry and protected place. Leaving the lawn tractor outdoors, exposed to the elements, will result in materially shortening its life.



### WARNING

Electrical storage batteries give off high inflammable hydrogen gas when charging and continue to do so for some time after receiving a steady charge. Do not under any circumstances allow an electric spark or an open flame near the battery. Do not lay tools across battery terminals as this may result in a spark or short circuit which may cause an explosion. Be careful to avoid spilling any electrolyte on hands or clothing.

## LUBRICATION

### ENGINE OIL

The engine crankcase is filled with ship-away oil. This oil may be used for the first 30 hours of engine operation at temperatures between 90 degrees F. and 0 degrees F. If temperatures are not within this range, drain the oil from the crankcase and replace the new oil as specified in the "Lubrication Table." The engine oil must be drained and replaced with new oil every 30 hours of engine operation.

To aid starting, the selection of crankcase lubricating oils should be based on the lowest anticipated temperatures until the next drain period.

We recommend IH Low Ash Engine Oil for gasoline engines. IH Low Ash Engine Oil exceeds API Service Classification SE. It is specifically designed for heavy duty service in gasoline engines, and is formulated to minimize metallic deposits, lengthen spark plug and valve life. IH Low Ash Oil used with unleaded gasoline is the ideal combination to maintain performance and extend engine life.

If other than IH Low Ash Engine Oil is used it must meet API Service Classification SE. For maximum engine life select API SE oils with lowest levels of barium, calcium, or magnesium additives and minimum ash content (approximately 0.5%). Lubricant suppliers will normally furnish this information on their engine oils.

Multi-viscosity numbered oils such as SAE 10W-30 or SAE 10-40 must not be used above 32 degrees Fahrenheit.

Regularly check the oil level of the engine crankcase to see that it is filled to the correct level.

**NOTE:**

Check the oil level only while the engine is stopped.

**NOTE:**

The gauge does not have to fill completely.

The crankcase oil filler cap has the oil level gauge attached to it. To check the oil level, press down on the rubber plunger and release. If any oil is visible in the clear tube of the gauge, the oil level is "OK."

## LUBRICATION GUIDE

The specific areas which require lubrication are shown on the following illustrations. A list is provided and is numbered to correspond with each illustration.

The symbols in the illustrations, indicate the method of application and the hourly intervals to apply the lubricant. A key to the symbols and lubricant to be used is provided below.

**NOTE:**

Any variation from this key will be provided with the list corresponding to the illustration.

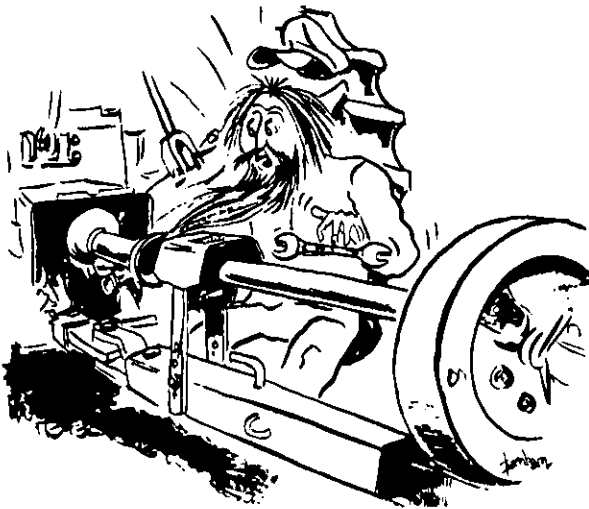

**CAUTION:**

Avoid loose fitting clothing, which could catch on moving or rotating mechanisms.

Check the oil level at hourly intervals shown on symbols. If the level is low, add the specified lubricant to bring up the proper height.

Use oil can at hourly intervals shown on symbols. Use IH No. 1 engine oil.

Use a pressure lubricating gun and apply IH 251H EP Grease (or equivalent No. 2 multi-purpose lithium grease) sufficient to flush out the old grease and dirt. Lubricate at hourly intervals indicated on symbols.

At hourly intervals shown on symbols remove the crankcase drain plug and oil filter and drain the oil from the crankcase and oil filter while the engine is warm. Replace drain plug and oil filter and refill with new oil to the "FULL" marks on the oil level gauge. Refer to the "ENGINE OIL TABLE" for the proper viscosity oil.

Drain (while warm), flush, and refill at hourly intervals shown on symbols. Use IH Hy-Tran except as noted.

## HYDROSTATIC MODEL

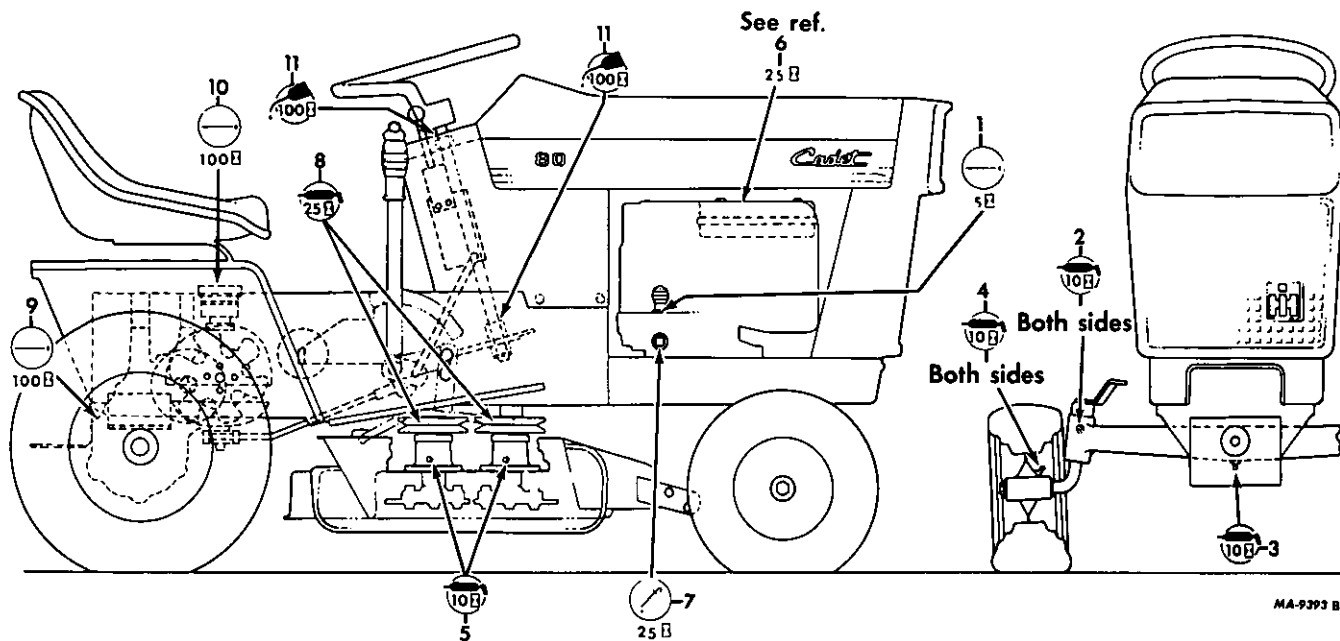

MA-9393 B

1. Oil filler cap and oil minder
2. Steering knuckles (2)
3. Front axle pivot pin
4. Front wheels
5. Mower spindle bearings (2)
6. Air cleaner

8. Mower pulleys (2)
9. Gear reduction drive  
NOTE: Refer to "Lubrication Table."
10. Hydrostatic drive

### NOTE:

When operating under extremely dusty conditions, check and service the element if necessary. Wash the element in soap and water. Then, wrap the foam element in a cloth and squeeze dry. Saturate the element in engine oil (SAE-30). Squeeze the element to remove excess oil and reassemble and fasten to the carburetor. Also, replace air cleaner gaskets and mounting gaskets that are worn or damaged, to prevent dirt or dust entering engine through improper sealing.

7. Engine crankcase drain plug  
NOTE: Refer to "Lubrication Table."

### NOTE:

As long as oil is visible in the clear tube of the gauge, the level is "OK."

### NOTE:

When cold 2-inches from top, when hot  $\frac{3}{4}$ -inches from top.

### NOTE:

If fluid is used which does not meet requirements of IH B-6 Specification, Cub Cadet Company will not be responsible for substandard performance of the transaxle. Failures due to use of improper fluid are not covered by warranty. FOR MAXIMUM PROTECTION USE IH HY TRAN® FLUID.

11. Steering wheel bushings (2)

### NOTE:

Apply two or three drops of light oil and rotate the steering wheel to distribute the oil.

## GEAR DRIVE MODEL

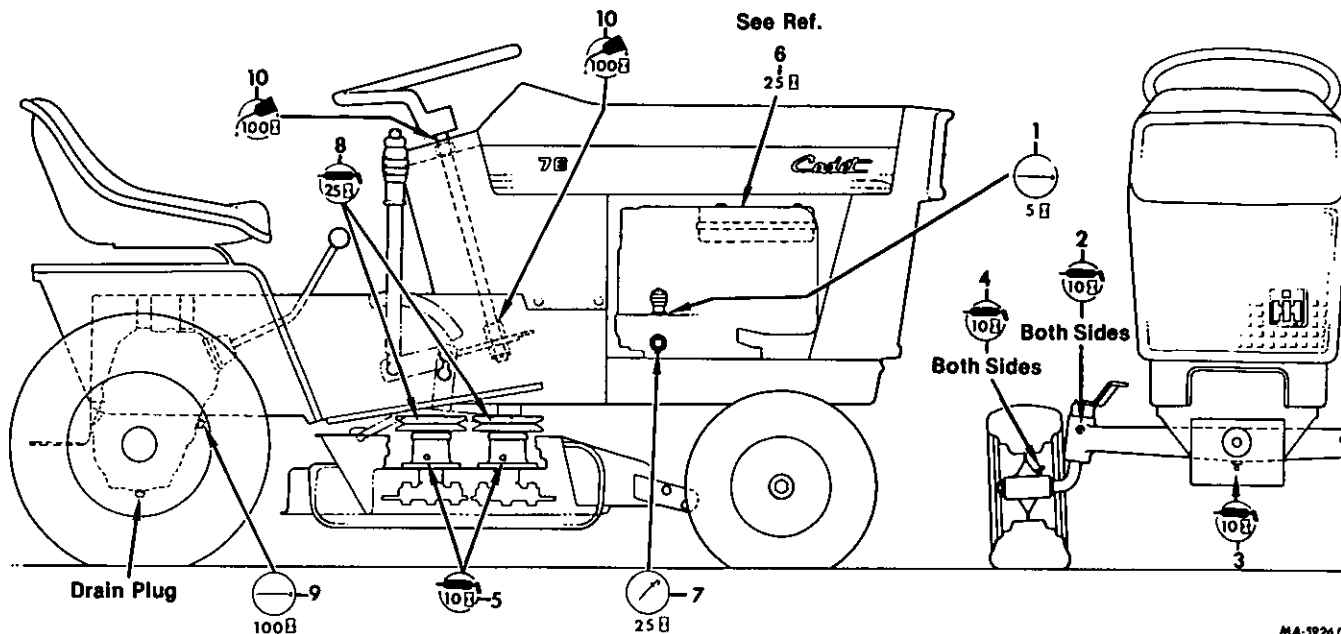

### 1. Oil filler cap and oil minder

#### NOTE:

As long as oil is visible in the clear tube of the gauge, the level is "OK."

2. Steering knuckles (2)
3. Front axle pivot pin
4. Front wheels
5. Mower spindle bearings (2)
6. Air cleaner

#### NOTE:

When operating under extremely dusty conditions, check and service the element if necessary. Wash the element in soap and water. Then, wrap the foam element in a cloth and squeeze dry. Saturate the element in engine oil (SAE-30). Squeeze the element to remove excess oil and reassemble and fasten to the carburetor. Also, replace air cleaner gaskets and mounting gaskets that are worn or damaged, to prevent dirt or dust entering engine through improper sealing.

### 7. Engine crankcase drain plug

NOTE: Refer to "Lubrication Table."

8. Mower pulleys (2)
9. Transaxle

#### NOTE:

Check the oil level and add IH Hy-Tran® Fluid if necessary. Oil level should be no more than approximately 1/2-inch from the bottom of the plug.

#### NOTE:

If fluid is used which does not meet requirements of IH B-6 Specification, Cub Cadet Company will not be responsible for substandard performance of the transaxle. Failures due to use of improper fluid are not covered by warranty. FOR MAXIMUM PROTECTION USE IH HY TRAN® FLUID.

### 10. Steering wheel bushings (2)

#### NOTE:

Apply two or three drops of light oil and rotate the steering wheel to distribute the oil.

# LUBRICATION TABLE

Point of Lubrication	Check at Hours	Change at Hours	Capacity	Anticipated Air Temperature		
				Above + 32°F.	- 32° to 0°F.	Below 0°F.
Engine Crankcase	5	25	1 qt.	I.H. Low Ash Engine Oil SAE-30	I.H. Low Ash Engine Oil SAE-10W	I.H. No. 1° Engine Oil SAE-5W-20 or SAE-5W
Transaxle Hydrostatic Drive Gear Reduction Drive	Check oil level once a year or every 100 hours and add IH HY-Tran® Fluid if necessary					

**NOTE:** Do not substitute 10W-30 or 10W-40.

# MAINTENANCE GUIDE

## HYDROSTATIC MODEL

Operation to be performed	Before each use	10 hours or once a month	25 hours or twice a season	Before Storage
Check engine oil	X			
Fill gas tank	X			
Grease front wheels		X		X
Grease mower spindle bearings		X		X
Service air cleaner			X	
Check belt guides and belt tension			X	
Check spark plug			X	
Service battery		X		
Change oil	After first 5 hours			
Clean Mower			X	
Sharpen mower blades			X	
Mower pulleys (2)			X	
Drain fuel tank				X
Examine Hydrostatic fan For worn or broken blades				X

# MAINTENANCE GUIDE

## GEAR DRIVE MODEL

Operation to be performed	Before each use	10 hours or once a month	25 hours or twice a season	Before Storage
Check engine oil	X			
Fill gas tank	X			
Grease front wheels		X		X
Grease mower spindle bearings		X		X
Service air cleaner			X	
Check belt guides and belt tension			X	
Check spark plug				X
Service battery		X		
Change oil	After first 5 hours		X	
Clean Mower			X	X
Sharpen mower blades			X	
Mower pulleys (2)			X	
Drain fuel tank				X

## TROUBLE SHOOTING

### Possible Cause

### Possible Remedy

#### LACK OF POWER

Choke partially closed . . . . .	Open choke.
Restricted air filter element . . . . .	Clean or replace element.
Carburetor improperly adjusted . . . . .	Adjust carburetor.
Faulty ignition . . . . .	Check spark plug.*

#### HARD TO START OR WILL NOT START

No gasoline in fuel tank or carburetor . . . . .	Fill the fuel tank with non-leaded or regular gasoline and check the carburetor, and fuel shut-off valve.
Engine will not crank . . . . .	The Lawn Tractor has an interlock safety starting system. The mower clutch control must be fully disengaged and the clutch pedal fully depressed. Charge the battery.
Choked improperly, flooded engine . . . . .	Follow starting instructions.
Water in gasoline . . . . .	Drain the fuel tank and carburetor. Use new fuel and dry the spark plug.
Defective ignition or loose wiring . . . . .	Check the wiring and spark plug.
No Spark . . . . .	Check the high tension wire. Charge the battery.
Spark plug dirty or improper gap . . . . .	Clean, adjust the gap to .030 inch, or replace the plug.

\*See your authorized dealer.



**ENGINE OPERATES IRREGULARLY, KNOCKS, OR SMOKES**

Spark plug dirty, wrong gap, or wrong type . . . . .	Clean, reset the gap to .030 inch, or replace.
Restricted air cleaner . . . . .	Clean or replace the element.
Running on choke position . . . . .	Move throttle control to fast position.
Carburetor improperly adjusted . . . . .	Adjust carburetor.
Poor or weak spark . . . . .	Check spark plug and wiring.*
Engine smokes . . . . .	Check combination oil filler cap and oil level gauge and be sure cap is securely tightened.
Engine correctly timed . . . . .	*

**ENGINE OVERHEATS**

Excessive load on engine . . . . .	Reduce excessive load.
Lack of lubrication . . . . .	Fill crankcase to proper level.
Carburetor improperly adjusted . . . . .	Adjust carburetor.
Engine cooling fins plugged . . . . .	Clean out trash.
Engine improperly timed . . . . .	*

**FREQUENT BATTERY DISCHARGE**

Wiring . . . . .	Check all wire terminals for looseness.
Battery . . . . .	Replace battery if necessary.

**HYDROSTATIC UNIT OVERHEATS**

Fan blades broken . . . . .	Replace fan.*
Fan blades excessive wear . . . . .	*

\*See your authorized dealer.

# SPECIFICATIONS

	182132 Cadet	282132 Cadet	382132 Cadet	383132 Cadet
<b>CAPACITIES (Approximate)</b>	1 Gallon (3.79L)			
Fuel Tank .....	2¼ Pints (1.06L)		3 Pints (1.42L)	
Crankcase .....	2¾ Pints (1.3L)		2¾ Pints (1.3L)	
Transmission		1½ Pints (.71L)		1½ Pints (.71L)
Gear drive .....	2¾ Pints (1.3L)			
Hydrostatic .....	Briggs and Stratton 191707		Briggs and Stratton 252707	
Differential .....	One			
<b>ENGINE</b>	3-inch (76.2mm)		3-7/16-inch (87.3mm)	
Make and Model .....	2¾-inch (69.8mm)		3-3/8-inch (60.3mm)	
Number of Cylinders .....	10.4 cu. in. (.31L)		24.3 cu. in. (.39L)	
Bore .....	1800 RPM			
Stroke .....	3500 RPM			
Displacement .....	.007-inch (.17mm)			
Engine speed (Governed)	.011-inch (.27mm)			
Minimum speed .....	Magneto			
Maximum no load speed (High Idle) .....	.030-inch (.76mm)			
Valve clearance (Engine Cold)	.020-inch (.50mm)			
Intake .....	Negative			
Exhaust .....	Suction lift			
<b>ELECTRICAL SYSTEM</b>	36-inch (914mm)			
Ignition .....	1½ to 4¼-inch (38.1 to 108mm)			
Spark plug gap (14mm) (Champion RCJ-8 or equivalent) .....	V-belt with clutch			
Breaker point gap .....	13 x 5.00-6			
Battery terminal grounded .....	18 x 8.50-8	18 x 9.50-8		
<b>GENERAL</b>	12 lbs./sq. inch (82.7 kPa)			
Type cutter bar .....	68-inches (1727mm)			
Width of cut .....	42½-inches (1080mm)			
Adjustable cutting height (Approx.) .....	62.2-inches (1580mm)			
Mower drive .....	420 lbs. (191 kg.)			
Tire sizes	430 lbs. (195 kg.)			
Front—2 ply tubeless .....				
Rear—2 ply tubeless .....				
Tire inflation pressure .....				
Turning radius .....				
Wheel base .....				
Length overall .....				
Weight (Approx.) .....				

## GROUND SPEEDS

### HYDROSTATIC DRIVE MODELS

Speed: Forward .....	.0 to 5.5 mph (0 to 8.8 km/h)
Reverse .....	.0 to 2.35 mph (0 to 3.7 km/h)

### GEAR DRIVE MODELS

Speed: 1st .....	1.91 mph (3.0 km/h)
2nd .....	3.42 mph (5.5 km/h)
3rd .....	5.06 mph (8.1 km/h)
Reverse .....	2.64 mph (4.2 km/h)

# MEASUREMENT UNITS

English Unit	Metric Equivalent (SI)
	<b>Area</b>
1 square inch (in <sup>2</sup> )	6.45 square centimeter (cm <sup>2</sup> )
1 acre	0.405 hectare (ha)
	<b>Force</b>
1 pound-force (lbf)	4.45 newton (N)
	<b>Length</b>
1 foot (ft)	304.8 millimeter (mm), 30.5 centimeter (cm), 0.305 meter (m)
1 inch (in)	25.4 millimeter (mm), 2.54 centimeter (cm)
1 mile	1609 meter (m), 1.61 kilometer (km)
	<b>Mass</b>
1 pound (lb)	0.454 kilogram (kg)
	<b>Power</b>
1 horsepower (hp)	0.746 kilowatt (kW)
	<b>Pressure</b>
1 pound-force per square inch, psi (lbf/in <sup>2</sup> )	6.89 kilopascal (kPa), 0.00689 megapascal (MPa)
	<b>Temperature</b>
t degree Fahrenheit (°F)	$\frac{(t-32)}{1.8}$ degree Celsius (°C)
	<b>Torque</b>
1 pound-force foot (lbf-ft)	1.356 newton meter (N-m)
	<b>Velocity</b>
1 mile per hour (mph)	1.61 kilometer per hour (km/h)
	<b>Volume</b>
1 US bushel	0.035 cubic meter (m <sup>3</sup> )
1 US gallon (US gal)	3.79 liter (L)
1 US quart (US qt)	0.946 liter (L)

# Accidents can be prevented with your help

No accident-prevention program can be successful without the wholehearted co-operation of the person who is directly responsible for the operation of equipment.

To read accident reports from all over the country is to be convinced that a large number of accidents can be prevented only by the operator anticipating the result before the accident is caused and doing something about it. No power-driven equipment, whether it be transportation or processing, whether it be on the highway, in the harvest field or in the industrial plant, can be safer than the man who is at the controls. If accidents are to be prevented—and they can be prevented—it will be done by the operators who accept a full measure of their responsibility.

It is true that the designer, the manufacturer, the safety engineer can help; and they will help, but their combined efforts can be wiped out by a single careless act of the operator.

It is said that ***“the best kind of a safety device is a careful operator.”*** We ask you to be that kind of an operator.

**INTERNATIONAL HARVESTER COMPANY**

**401 NORTH MICHIGAN AVE. / CHICAGO, ILLINOIS 60611 / U.S.A.**

**1 096 368 R3. —**

**PRINTED IN UNITED STATES OF AMERICA**

**Form No. 772-3012**