

Constant Running Hydraulic Pump Installation Guide

Drives covered:

M81125	Type CR1 (3 L) Constant Running Pump 12 V
M81127	Type CR1 (3 L) Constant Running Pump 24 V
M81126	Type CR2 (4.5 L) Constant Running Pump 12 V
M81128	Type CR2 (4.5 L) Constant Running Pump 24 V

Document number: 81179-3

March 2001

Raymarine
ON BOARD



Important information

Safety notices

WARNING: Product installation

This equipment must be installed and operated in accordance with the instructions contained in this handbook. Failure to do so could result in poor product performance, personal injury and/or damage to your boat.

Because correct performance of the boat's steering is critical for safety, we **STRONGLY RECOMMEND** that an Authorized Raymarine Service Representative fits this product.

WARNING: Navigation aid

Although we have designed this product to be accurate and reliable, many factors can affect its performance. As a result, it should only be used as an aid to navigation and should never replace commonsense and navigational judgement. Always maintain a permanent watch so you can respond to situations as they develop.

EMC conformance

All Raymarine equipment and accessories are designed to the best industry standards for use in the recreational marine environment. The design and manufacture of Raymarine equipment and accessories conform to the appropriate Electromagnetic Compatibility (EMC) standards, but correct installation is required to ensure that performance is not compromised.

Handbook information

To the best of our knowledge, the information in this handbook was correct when it went to press. However, Raymarine cannot accept liability for any inaccuracies or omissions it may contain. In addition, our policy of continuous product improvement may change specifications without notice. As a result, Raymarine cannot accept liability for any differences between the product and the handbook.

Introduction

Product description

Welcome to the installation guide for the Raymarine constant running (CR) hydraulic pump. This product is intended to operate the boat's steering mechanism as part of a Raymarine autopilot system.

The pump provides an ideal drive system for large boats and heavy duty steering applications. It is primarily designed for use on boats with an existing hydraulic steering system. Alternatively, you can use this pump on a boat with mechanical steering in conjunction with a secondary steering ram and bypass valve.

The pump contains a built-in reservoir that holds hydraulic fluid and an integral solenoid valve that controls the flow of hydraulic fluid to the steering ram. The autopilot system steers the boat by using the solenoid control valves to control the flow of hydraulic fluid to the steering ram.

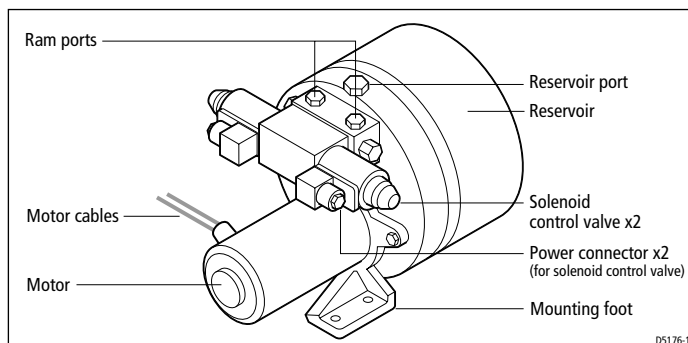

Figure 1: Main parts of the CR pump

Contents

This guide contains:

1	Product specifications	page 4
2	Installation instructions	page 5
3	Maintenance information	page 17

Specifications

Pump specifications

Table 1: Pump specifications

Performance (at nominal voltage)	Type CR1 M81125 (12 V) M81127 (24 V)	Type CR2 M81126 (12 V) M81128 (24 V)
Ram capacity	350-500 cc (21-30 in ³)	500-1200 cc (30-73 in ³)
Ram	single or double ended	
Maximum stall pressure (at 12 V)	50 bar (750 psi)	50 bar (750 psi)
Peak flow rate (no load)	3000 cc/min (180 in ³ /min)	4500 cc/min (270 in ³ /min)
Other information	(applies to Types CR1 and CR2)	
	protected for use in engine compartments	
	CE approvals - conforms to: 89/336/EC (EMC), EN60945:1997 94/25/EC (RCD), EN28846:1993	

Pump dimensions

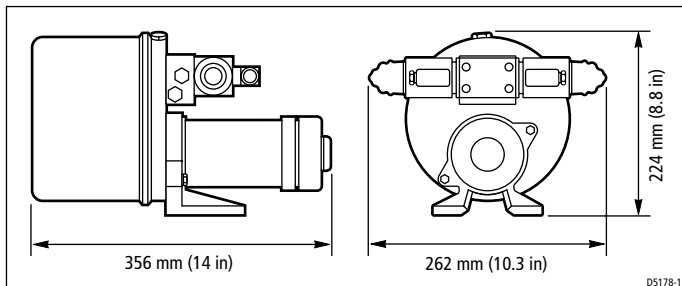

Figure 2: Pump dimensions

Installation instructions

Parts required

To install this drive you will need:

- Parts supplied:
 - CR hydraulic pump
 - if required: BSP to NPT adaptors (x3)
- Additional parts:
 - suitable hydraulic pipes, hydraulic fluid, T-pieces, pipe fittings and thread-sealing compound (see *page 8*)
 - suitable securing bolts, lock washers/lock nuts (see *page 7*)
 - suitable cable and electrical connectors for the drive motor and solenoid control valves (see *page 13*)
 - CR interface (to connect to Type 100/300 course computer)
 - bypass valve (if connecting to a secondary steering ram)

Note: Obtain these additional parts before you start installation.

Installation steps

WARNING: Electrical safety

Make sure you have switched off the power supply before you start installing this product.

Follow these steps to install your CR pump:

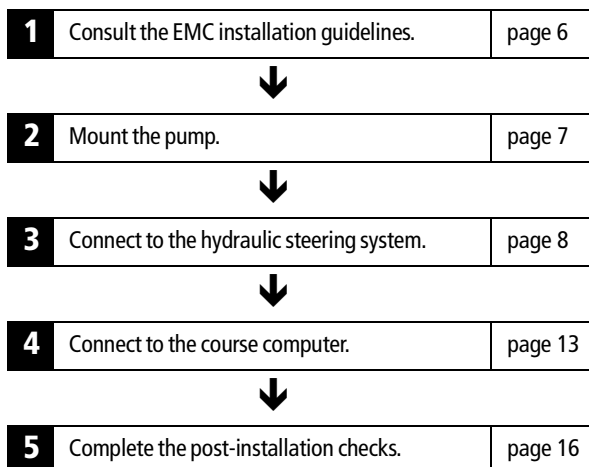

1. EMC installation guidelines

All Raymarine equipment and accessories are designed to the best industry standards for use in the recreational marine environment.

Their design and manufacture conforms to the appropriate Electromagnetic Compatibility (EMC) standards, but correct installation is required to ensure that performance is not compromised. Although every effort has been taken to ensure that they will perform under all conditions, it is important to understand what factors could affect the operation of the product.

The guidelines given here describe the conditions for optimum EMC performance, but it is recognized that it may not be possible to meet all of these conditions in all situations. To ensure the best possible conditions for EMC performance within the constraints imposed by any location, always ensure the maximum separation possible between different items of electrical equipment.

For **optimum** EMC performance, it is recommended that **wherever possible**:

- Raymarine equipment and cables connected to it are:
 - At least 3 ft (1 m) from any equipment transmitting or cables carrying radio signals e.g. VHF radios, cables and antennas. In the case of SSB radios, the distance should be increased to 7 ft (2 m).
 - More than 7 ft (2 m) from the path of a radar beam. A radar beam can normally be assumed to spread 20 degrees above and below the radiating element.
- The equipment is supplied from a separate battery from that used for engine start. Voltage drops below 10 V, and starter motor transients, can cause the equipment to reset. This will not damage the equipment, but may cause the loss of some information and may change the operating mode.
- Raymarine specified cables are used. Cutting and rejoining these cables can compromise EMC performance and must be avoided unless doing so is detailed in the installation manual.
- If a suppression ferrite is attached to a cable, this ferrite should not be removed. If the ferrite needs to be removed during installation it must be reassembled in the same position.

Suppression ferrites

This figure shows typical cable suppression ferrites used with Raymarine equipment. Always use the ferrites supplied by Raymarine.

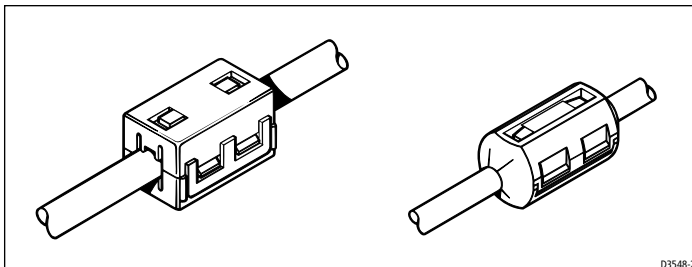

Connections to other equipment

If your Raymarine equipment is to be connected to other equipment using a cable not supplied by Raymarine, a suppression ferrite **MUST** always be attached to the cable near to the Raymarine unit.

2. Pump mounting

CAUTION:

During installation, take care not to knock the CR pump's mounting feet on any solid structures as the impact may damage the aluminium castings.

Mount the CR pump:

- on a substantial member to avoid vibration that could damage the hydraulic pipes
- on a suitable horizontal surface clear of spray and possible water immersion
- level or above the hydraulic steering ram to prevent air collecting in the ram
- as close to the steering ram as possible
- using suitable bolts with lock nuts/lock washers

Note: *As the pump can transmit noise to the boat's structure, we recommend placing rubber mounts between the pump and the boat's structure to reduce noise transfer.*

CAUTION:

Locate the pump in a ventilated and soundproof enclosure.

3. Hydraulic connections

CAUTION:

Before you connect the autopilot pump to your hydraulic system we strongly recommend that you consult the steering gear manufacturer.

General guidelines

CAUTION:

Absolute cleanliness is essential when working with hydraulic systems. Even the smallest particle of dirt could prevent the steering system check valves from working properly.

- All pipes used to fit the pump should match, or exceed, the specification of the existing steering system pipes. Contact the steering system manufacturer if you need more information.
- Use *flexible* pipe to connect the pump to the boat's steering system - this avoids strain on the pipes.
- Try to keep hydraulic fluid loss to a minimum when installing the pump. This will reduce the time and effort required to bleed the system of trapped air after installation:
 - non-pressurized systems: temporarily fit a non-venting plug to the helm reservoir vent to minimize fluid loss
 - pressurized systems:

WARNING:

Before disconnecting any pipes on pressurized systems, you MUST release the pressure at the reservoir by following the manufacturer's instructions.

- The ram ports on the CR pump are tapped to $\frac{1}{4}$ in BSP and the reservoir port is tapped to $\frac{3}{8}$ in BSP. Three NPT adaptors are included for conversion to NPT where required.
- Follow the manufacturer's instructions if you fit any T-pieces.
- Make sure all hydraulic pipes slope upwards towards the reservoir.
- A set of bleed valves near the steering ram, fitted at the highest point, will allow any air to escape upwards.

CAUTION:

Do not use PTFE tape on hydraulic pipe connections. If necessary use a pipe-sealing compound to ensure a leakproof joint.

CAUTION:

Before running the pump for the first time, make sure the system contains sufficient hydraulic fluid. You will damage the pump if you let it run when 'dry'.

Check valves

For single-steering position boats:

- Consult the steering gear manufacturer to determine whether the helm pump is fitted with reversing check valves:
 - without check valves, the autopilot pump will drive the helm pump (sometimes referred to as 'motoring the wheel') instead of moving the steering ram
- If the boat has a single helm pump system **without** check valves, you must incorporate a double pilot check valve (part number: M81166) as shown in *Figure 3*.
- A double pilot check valve may also be necessary on long pipe runs - otherwise pipe expansion may cause poor autopilot performance. Install the check valve as shown in *Figure 3*.

Note: *If the boat has two steering positions, it will already have check valves installed so the two wheels can operate independently.*

Hydraulic steering systems

There are three basic types of hydraulic steering systems:

- two line system
- three line system
- two line pressurized system

On the following pages we describe each type of system and typical connection points for the autopilot pump. For all of these systems you will need to connect a third hydraulic pipe as shown between the autopilot pump and the helm pump or dedicated system reservoir.

Two line systems

Figure 3 shows a typical two line steering system. Hydraulic fluid flows into the ram in either direction, depending on the direction the helm pump rotates.

Connect the autopilot pump to the steering system as shown in Figure 3.

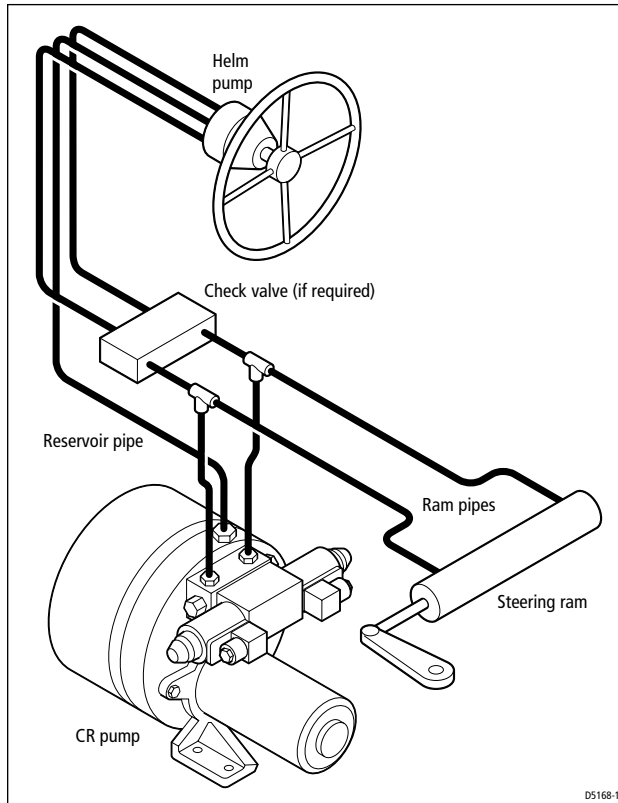

Figure 3: Autopilot pump location for two line systems

Two line pressurized systems

Two line pressurized systems have an external pressurized reservoir. This reduces the possibility of introducing air into the system and reduces any steering ‘sponginess’ caused by pipe expansion.

Connect the autopilot pump to the steering system as shown in *Figure 4*.

Note: Refer to the manufacturer’s instructions for de-pressurizing and re-pressurizing the system.

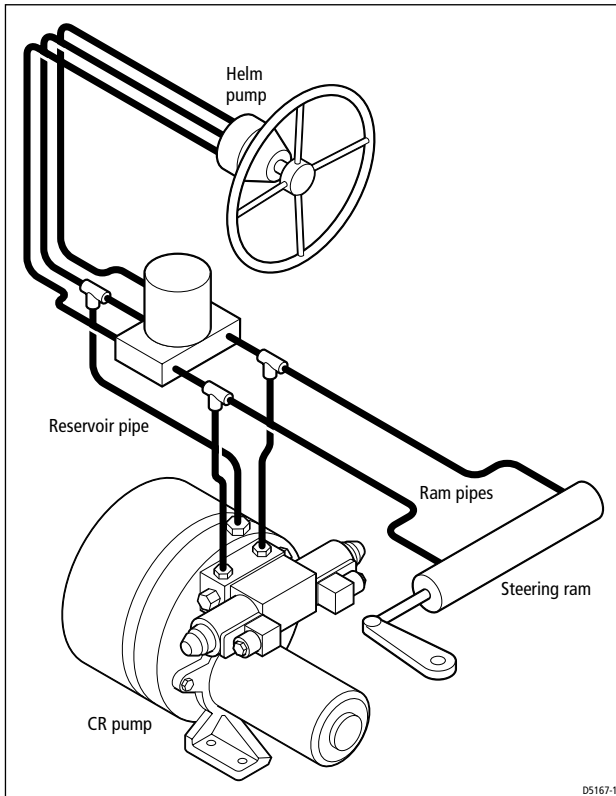

Figure 4: Autopilot pump location for two line pressurized systems

Three line systems

In a three line system, the hydraulic fluid flows in only one direction:

- out of the helm pump to the ram
- returning from the other side of the ram to the reservoir via a common return line

The system will include a check valve block to direct all returned fluid from the ram back to the reservoir.

Connect the autopilot pump to the steering system as shown in *Figure 5*.

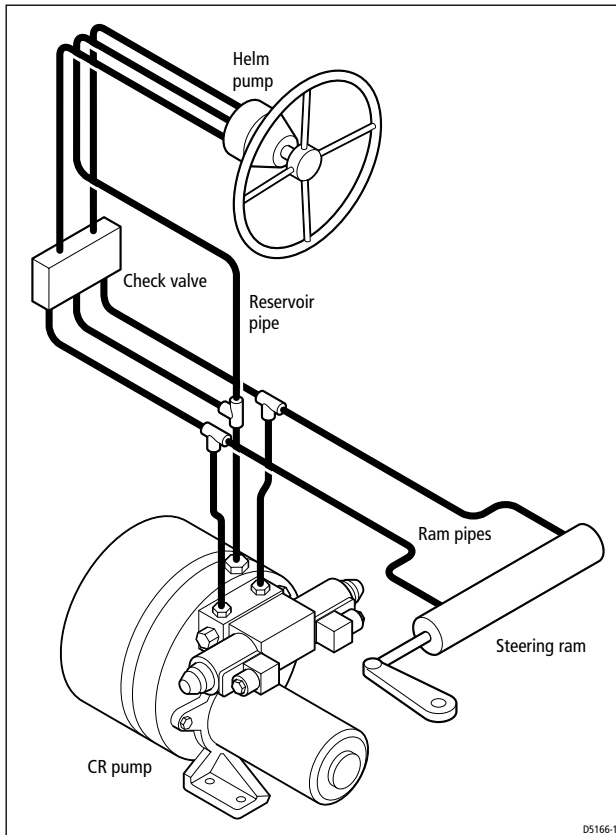

Figure 5: Autopilot pump location for three line systems

4. Connecting to the course computer

WARNING: Electrical safety

Make sure the power supply is switched off before you make any electrical connections.

The CR pump has electrical connections for:

- motor supply: two single-core cables
- solenoid control valve supply: two plug-in connectors (supplied)

Note: When routing cables, refer to the EMC installation guidelines.

Connecting to Type 150/400 course computer

Make the following connections:

1. CR pump motor supply:
 - using appropriate cables (see *Table 2*) connect the CR pump motor to the boat's power supply, via an appropriate circuit breaker and fuse (as specified in *Figure 6*)
2. Solenoid control valves – using suitable cable (at least 16 AWG or 1.5 mm² for runs up to 16 m/52 ft):
 - for the first valve: connect one core to the **MOTOR A** terminal and the other core to one of the **SOLENOID** terminals at the course computer (see *Figure 6*)
 - for the second valve: connect one core to the **MOTOR B** terminal and the other core to the other **SOLENOID** terminal

Note: If installing the pump on a boat with mechanical steering, you need to connect a bypass valve to the **CLUTCH** terminals (see page 15).

Table 2: Recommended cable sizes

Pump motor cable length (distribution panel to pump)	Cable gauge (AWG)	Copper area (mm ²)
12 V CR pumps		
up to 3 m (10 ft)	10	6
up to 7 m (23 ft)	8	10
up to 16 m (52 ft)	6	16
24 V CR pumps		
up to 3 m (10 ft)	12	4
up to 5 m (16 ft)	10	6
up to 10 m (32 ft)	8	10
up to 16 m (52 ft)	6	16

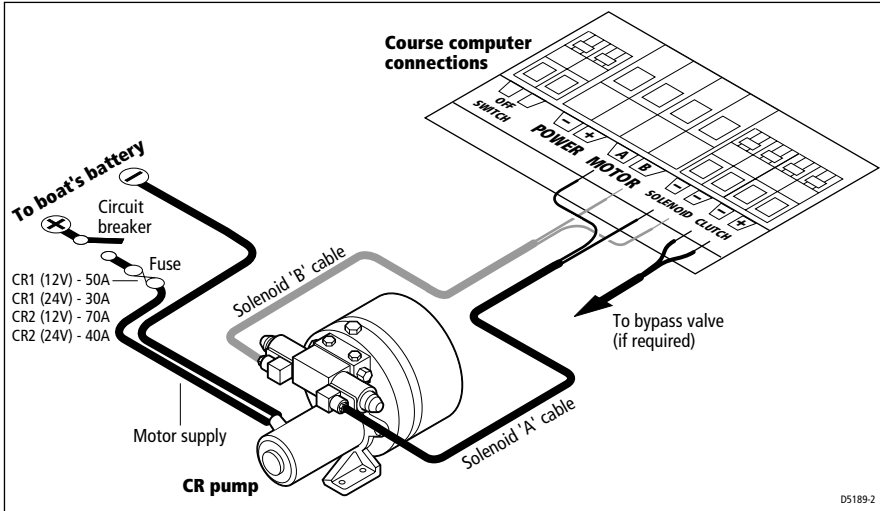

Figure 6: CR pump connections to a Type 150/400 course computer

Connecting to Type 100/300 course computer

When installing the CR pump with a Type 100/300 course computer we recommend using a Raymarine constant running (CR) interface (part number: M81129).

Connecting the CR interface

Run cables from the main power supply to:

- the motor on the CR pump
- the CR interface and then onto the course computer power connections

Install a suitable circuit breaker in the power supply to the complete system (as specified in the core pack installation guide).

Note: *It is important to use the correct cable size for the length of cable run between the pump and the power supply (see Table 2).*

The CR interface unit has connections for the solenoid valves (on the CR pump) and a bypass valve (if fitting to a mechanical steering system):

- connect the solenoid valves to the CR interface as shown in *Figure 7*, using at least 16 AWG (1.5 mm²) cable.

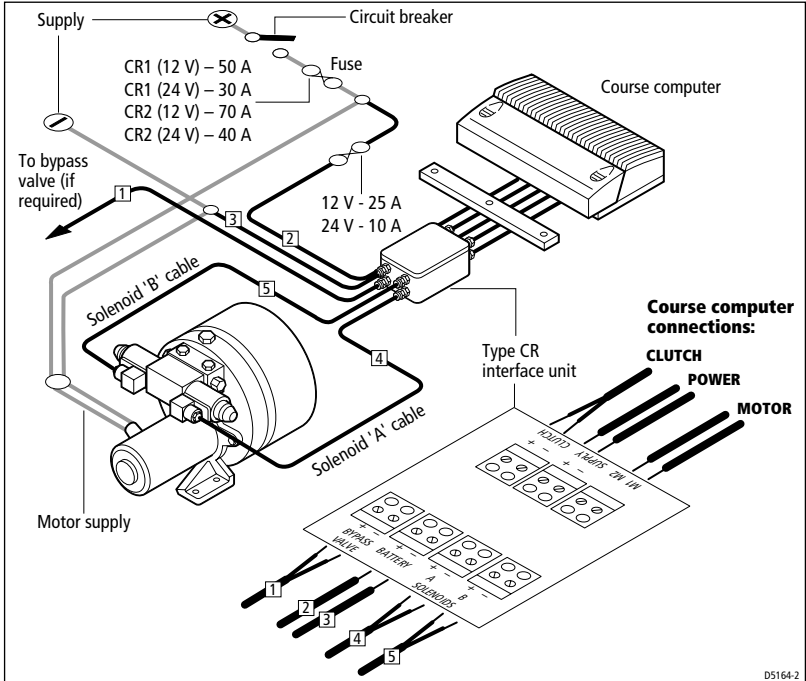

Figure 7: CR pump connections to a Type 100/300 course computer

Mechanical steering

If you are fitting the pump to a boat with mechanical steering you will need to connect it to a secondary steering ram, along with a solenoid-operated bypass valve (part no. M81167). The bypass valve allows you to switch between autopilot course control and manual steering. To fit to a mechanical steering system:

1. Use suitable hydraulic pipes to connect the pump to the secondary steering ram and a suitable reservoir.
2. Install the solenoid-operated bypass valve across these pipes (as shown in Figure 8).
3. Connect the bypass valve to:
 - the **CLUTCH** terminals on the course computer (Type 150/400 course computer), or
 - the **BYPASS** terminals on the CR interface (Type 100/300 course computer)

Note: Follow the manufacturer's instructions for mounting the hydraulic ram.

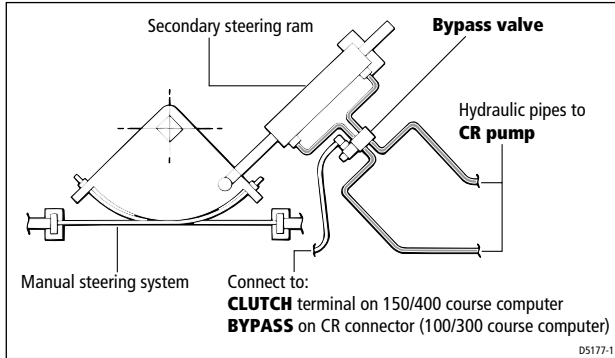

Figure 8: Connecting the bypass valve

5. Post-installation check

WARNING:

Keep clear of moving steering systems at all times. Protect moving parts from access during normal use.

Check the following points after installing the pump:

1. Is the pump installed as close to the steering ram as possible?
2. Is the pump secured to a substantial structure on the boat?
3. Have you connected a third hydraulic pipe between the helm pump and autopilot pump?
4. Have you fitted check valves where appropriate?
5. Are the hydraulic pipes made of a suitable flexible material (i.e. rubber or nylon) with a suitable pressure rating?
6. Have you sealed all hydraulic connections and checked for leakages?
7. Are power cables correctly routed and securely connected to the course computer?

You have now finished installing the pump. After installing the rest of the autopilot you must bleed all air from the system (see below).

Note: *When you have installed the entire autopilot system, you will also need to complete an autopilot steering check. Refer to the control unit handbook for more details.*

Bleeding the system

Bleeding the hydraulic system correctly is one of the most important steps when installing the autopilot hydraulic pump. If there is any air

in the system the steering will feel spongy, particularly when you turn the wheel to hardover.

CAUTION:

Any air in the hydraulic system will greatly reduce the performance of the autopilot and the overall steering system.

In addition to the manufacturer's instructions for bleeding the steering system, follow these steps to bleed the autopilot pump when you have installed and set up the rest of the autopilot system:

1. With the system in **auto** mode, press the **-10** button ten times:
 - the autopilot pump will try to drive the rudder to port
 - counter this rudder movement by turning the helm to starboard to keep the rudder stationary
 - you will be able to feel any air in the helm pump: any air in this side of the pump will rise to the helm pump and exhaust into the reservoir
 - continue until all of the air is out of this side of the pump
2. Clear any air on the other side of the pump:
 - press the **+10** button ten times
 - the autopilot will try to drive the rudder to starboard
 - counter the rudder movement by turning the helm to port
 - continue until all of the air is out of this side of the pump
3. Repeat in both directions until both sides of the help pump are totally free of air.

Note: *Monitor the reservoir at all times and top up with the manufacturer's recommended hydraulic fluid as required.*

CAUTION:

After installation and bleeding, leave the system for 24 hours then check for any air in the system or leaks at the joints and around the pump.

Maintenance

On a regular basis:

- check all connections and mountings are secure
- check pipes and cables for any signs of wear or damage
- check hydraulic pipes and connections for leaks

EMC servicing and safety guidelines

- Raymarine equipment should be serviced only by authorized Raymarine service technicians. They will ensure that service procedures/ replacement parts used will not affect performance. There are no user serviceable parts in any Raymarine product.
- Some products generate high voltages, so never handle the cables or connectors when power is being supplied to the equipment.
- When powered up, all electrical equipment produces electromagnetic fields. These can cause adjacent pieces of electrical equipment to interact with one another, with a consequent adverse effect on operation. In order to minimize these effects and enable you to get the best possible performance from your Raymarine equipment, guidelines are given in the installation instructions, to enable you to ensure minimum interaction between different items of equipment, i.e. ensure optimum Electromagnetic Compatibility (EMC).
- Always report any EMC-related problem to your nearest Raymarine dealer. We use such information to improve our quality standards.
- In some installations, it may not be possible to prevent the equipment from being affected by external influences. In general this will not damage the equipment but it can lead to spurious resetting action, or momentarily may result in faulty operation.

Product support

Raymarine products are supported by a worldwide network of distributors and Authorized Service Representatives. If you encounter any difficulties with this product, please contact either your national distributor, service representative, or the **Raymarine Technical Services Call Center**.

Raymarine Ltd

Anchorage Park
Portsmouth, Hampshire
England PO3 5TD
Telephone +44 (0)23 9269 3611
Fax +44 (0)23 9269 4642
www.raymarine.com

Raymarine Inc

22 Cotton Road, Suite 280
Nashua
NH 03063-4219, USA
Telephone +1 603 881 5200
Fax +1 603 864 4756
www.raymarine.com



Raymarine Technical Services Call Center

UK: +44 (0)23 9271 4713 or
+44 (0)23 9269 3611 ext. 1083

USA: +1 603 881 5200 or
1-800-539-5539 ext. 2333