

## SUPPLEMENTARY INSTRUCTION FOR 50K CONDENSERLESS UNITS

The following items are included in the base unit for field installation:

- a. Discharge Line Assembly
- b. Moisture and Liquid Indicator
- c. Filter - drier
- d. Crankcase Heater Relay Assembly
- e. Condenser Fan Relay Assembly

NOTE: One each of the above items is used on all units, except the 50K16-2 compressor model which has two each.

Install this unit in accordance with the instructions in the Unit Installation Instruction Book (50K8-1005 Rev.) except for the following items.

### AIR-COOLED CONDENSER LOCATION

The air-cooled condenser should not be located more than 60 feet above, or 15 feet below the base unit. Check the installation booklet with the condenser for installation details.

### CRANKCASE HEATERS

One crankcase heater (230 volt, 1 phase, 60 cycle) will be factory installed on the outside of the bottom plate of each compressor. The crankcase heater elements replace the need for the liquid lines solenoid valves. Each crankcase heater has 36 inch leads for wiring in the field.

### REFRIGERANT PIPING

Install the hot gas and liquid line between the base unit and the external condenser for each system being careful to connect the correct components in each system. Fig. 1 through 4 shows the location of the connections at the base unit. Fig. 5 through 7 shows the schematic piping layout for the various units when connected with the 9AB Air-Cooled Condenser. Table 2 shows the connection sizes at the base unit and recommends line sizes for various refrigerant line lengths. Consult the Installation Instructions of the condenser used and Part 3 of the System Design Manual for piping details and line sizes when greater lengths are used.

In order to prevent condensed liquid refrigerant or oil from causing damage to the compressor, install a trap in the vertical discharge line near the compressor. The trap may be installed within or adjacent to the base unit chassis. The height of the trap (or loop) should be 6 inches for every 10 feet of vertical discharge line. If the height of the vertical discharge line is such as to make a single trap impractical, the loop can be replaced by a check valve or several traps.

When installing refrigerant piping make certain it is well supported. Install piping with sufficient flexibility to make sure line vibrations are not transmitted to the building.

The openings in the chassis normally used for the water-cooled condenser water piping may be used to bring the lines into the unit.

Install the discharge line assembly, filter-drier and the moisture and liquid indicator in each circuit within the chassis of the base unit. Locate the filter-drier and the moisture and liquid indicator in the liquid line just before the liquid line enters the expansion valve. The moisture and liquid indicator goes between the filter-drier and the expansion valve.

### PRESSURE RELIEF PROTECTION

Refrigerant pressure relief protection must be provided for each system at the time of installation of the unit. A suitable fusible union, a liquid line soft solder joint within the base unit, or a rupture disc (Chicago Code) may be used depending on local codes, etc.

The 9AB6 receiver is provided with a 3/8" FPT fitting for the installation of a fusible union or rupture disc. The Cerro De Pasco Co. fusible union No. 5160-1 or No. 5250-1 (melting point 197 F or 203 F), Carrier Part No. EK41JN200 is suitable; check local codes.

### HEAD PRESSURE CONTROL

A condensing pressure (head pressure) control accessory package is available for use with the 9AB condensers. Consult the 9AB Instruction Sheets for details.

TABLE 1

Unit	Circuit No	Compressor		Evaporator Coil Liquid Line Connection	R-22 Pounds
		Model	Location		
50K8	(1 Circuit)	6D48	-	-	10
50K12 Single Compressor	(1 Circuit)	6D68	-	-	10
50K16 Single Compressor	(1 Circuit)	6D75	-	-	15
50K16 2 Compressor	No. 1	6D48	Left Side	Right End	10
	No. 2	6D48	Right Side	Left End	10

TABLE 2

Unit	Discharge Line Connection	Liquid Line Connection	Recommended Line Sizes					
			Linear Feet Piping					
			20		40		60	
			Liquid Line	Hot Gas	Liquid Line	Hot Gas	Liquid Line	Hot Gas
50K8	7/8	1/2	1/2	7/8	1/2	7/8	1/2	7/8
50K12 Single Compressor	7/8	5/8	5/8	7/8	5/8	1-1/8	3/4	1-1/8
50K16 (Ea. Circuit) 2 Compressor	7/8	1/2	1/2	7/8	1/2	7/8	1/2	7/8
50K16 Single Compressor	1-1/8	5/8	5/8	1-1/8	3/4	1-1/8	3/4	1-3/8

### REFRIGERANT CHARGE

The unit will be shipped with a 2 lb. holding charge of Refrigerant 22. In the standard installation, Refrigerant 22 will be used. However, on special applications, Refrigerant 500 may be used. Consult your Application Engineering Data for information concerning the use of Refrigerant 500. When Refrigerant 500 is used, change the expansion valve to the one shown in Table 3.

### REFRIGERANT CHARGE QUANTITY

During operation on Refrigerant 22 the base unit alone requires the number of pounds shown in Table 1. To this, add the needs for the refrigerant lines, condensers, and receivers (if used). Stamp the number of pounds used in the blank space provided on the nameplate.

TABLE 3 - VALVES FOR R-500 SERVICE

Unit	Sporlan Valve
50K8	PDE6G
50K12 Single Compressor	PDE9G
50K16 Single Compressor	PDE13G
50K16 2 Compressor	PDE6G (2) required

### DUAL PRESSURESTATS

Adjust the pressurestats according to pressure shown in Table 4.

TABLE 4

Refrig.	High Press. Switch		Low Press. Switch	
	Cut-In	Cut-Out	Cut-In	Cut-Out
22	284	364	83	46
500	218	265	67	30

**SPORLAN SEE-ALL MOISTURE AND LIQUID INDICATOR**

The moisture and liquid indicator must be full of liquid refrigerant to properly indicate the moisture content of the refrigerant. Operate the system at least 30 minutes before attempting to determine the moisture reading.

**CHARGING PROCEDURE**

The complete refrigerant system should be evacuated with a good vacuum pump before charging with refrigerant. When charging, connect a cylinder of refrigerant through a tee to a gauge and to the gauge port on the compressor service valve. Have the cylinder in the upright position to admit vapor only. Admit refrigerant to break the vacuum in the system. Start the compressor and modulate the valve on the cylinder to keep the suction pressure slightly under 50 psig. Charge the system until liquid refrigerant will bleed from the liquid level check port on the receiver and also until the sight glass is clear.\*

NOTE\* If the liquid refrigerant bleeds from the liquid level check port on the receiver but there is still flashing at the sight glass, there is an indication that there is a restriction in the liquid line or filter-drier.

Let the system operate for 20 minutes to balance out and recheck the refrigerant and oil levels.

The receiver has a bleeder port at the top to bleed non-condensables from the system. There has to be sufficient refrigerant in the system to make a liquid seal at the outlet of the receiver to trap the non-condensables in the top of the receiver before the bleeder port can be effective.

**WIRING**

The crankcase heater elements, heater relays, and the condenser fan relays are to be field wired. See Wiring Diagrams.

The crankcase heater relays are single pole, single throw, normally closed, relays. Each crankcase heater element is to be energized when its respective compressor is "OFF."

The condenser fan relays (S.P.S.T. Normally open) are to be mounted per the condenser Installation Instructions. The control voltage is supplied by the base unit. Follow the right wiring diagram so the condenser fans will continue to run if the compressor is shut down by one of its protective devices and the thermostat is still calling for cooling.

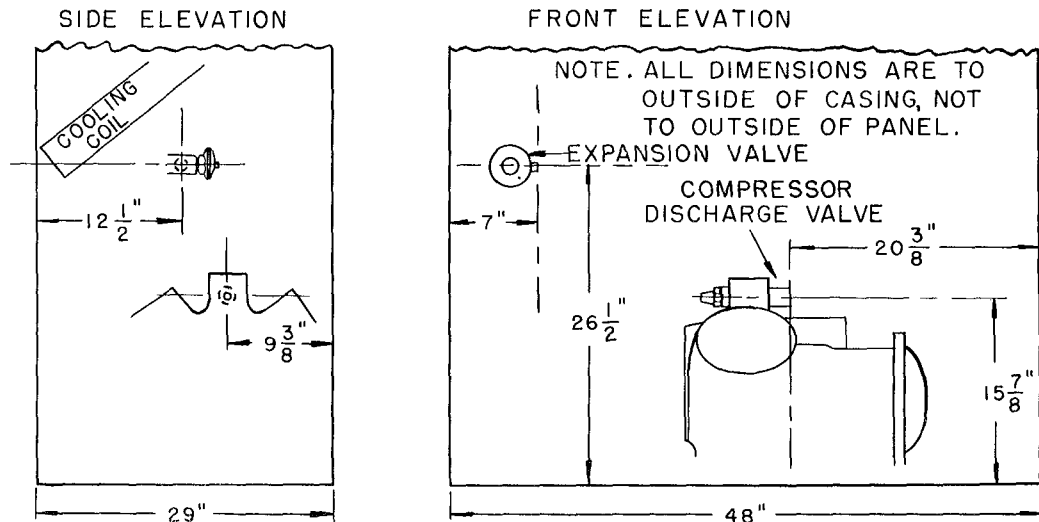

FIG. 1 - LOCATION OF COMPRESSOR DISCHARGE AND LIQUID CONNECTIONS 50K8



TABLE 5 - ELECTRICAL DATA

Current Characteristics	Locked Rotor Current Amps.				Full Load Current Amps.				50K				50K				50K										
	8		16 (1 Comp.) (2 Comp.)		8		16 (1 Comp.) (2 Comp.)		8		12		16 (1 Comp.)		8		16 (2 Comp.)		8		12		16 (1 Comp.) (2 Comp.)				
	12	16	120	250	24.9	35.7	55.6	24.9	8	65	100	160	235	4	6	4	2	2	1	1	185	98	80	35	60	80	35
208/220-3-60	120	180	120	250	24.9	35.7	55.6	24.9	8	65	100	160	235	4	6	4	2	2	1	1	185	98	80	35	60	80	35
440-3-60	60	90	60	125	11.9	17.5	27.2	11.9	12	135	170	260	400	8	10	8	6	4	4	4	390	160	135	40	25	40	17-1/2

- NOTES: 1. Wire sizes, lengths, fuse sizes, and dual element fuse sizes shown are for the branch circuit between the disconnect switch and the unit.  
 2. The branch circuit wire sizes and the corresponding maximum wire lengths tabulated will result in a 1% voltage drop at the nameplate full load amperage. The wire size listed and the maximum fuse sizes are in accordance with the National Electric Code.  
 3. Dual element fuses can be sized much closer to the actual running current than one-time link type fuses because of the built-in lag. Thus, dual element fuses give additional motor protection against both single phasing and locked rotor failure, should starter contacts fuse. Use dual element fuses for compressor protection on all installations. With properly selected fused disconnect switches, fuse reducers may be required.

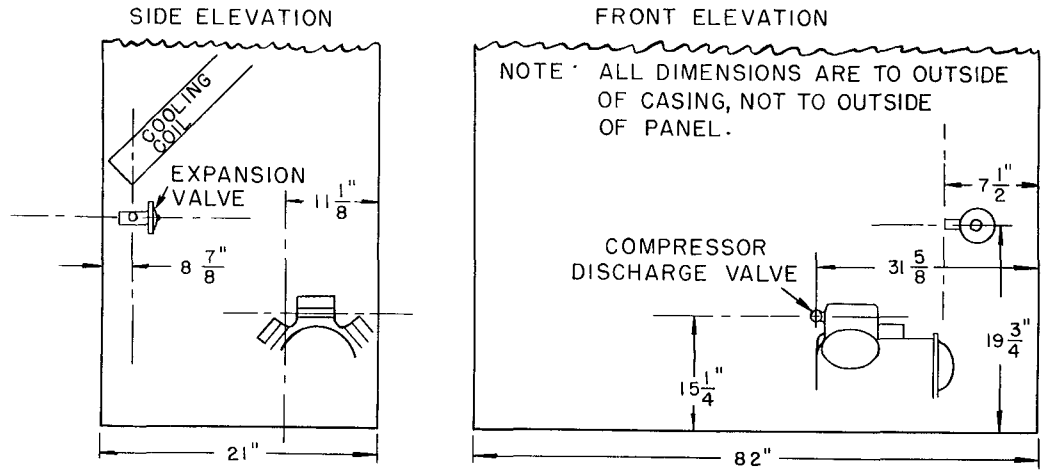

FIG. 2 - LOCATION OF COMPRESSOR DISCHARGE AND LIQUID CONNECTIONS 50K12

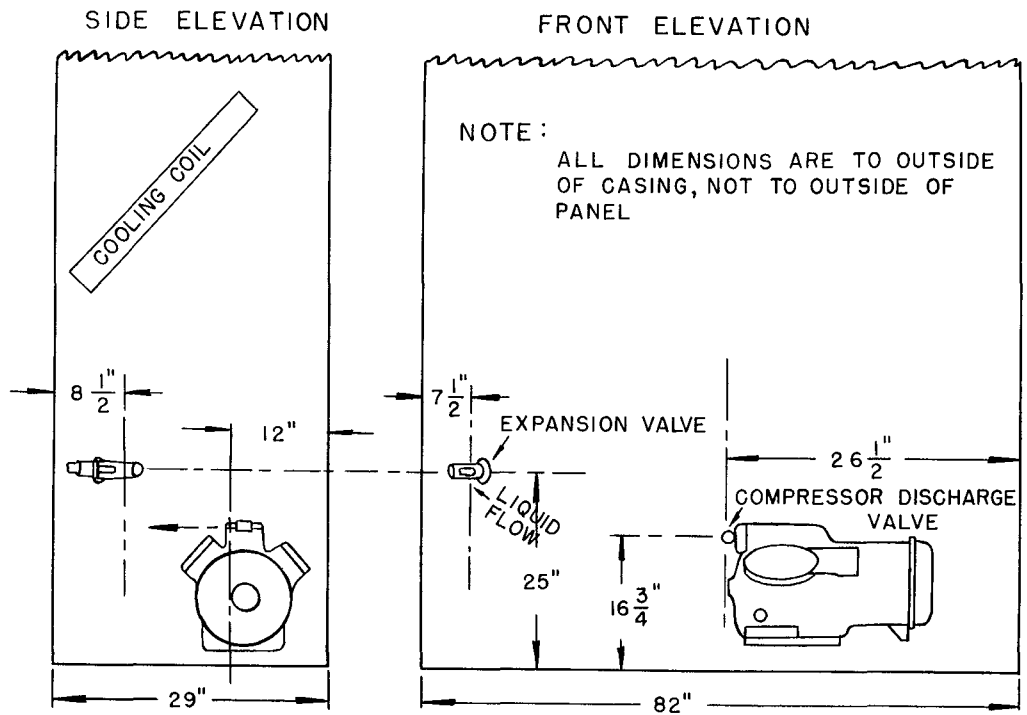

FIG. 3 - LOCATION OF COMPRESSOR DISCHARGE AND LIQUID CONNECTIONS 50K16 SINGLE COMPRESSOR MODEL

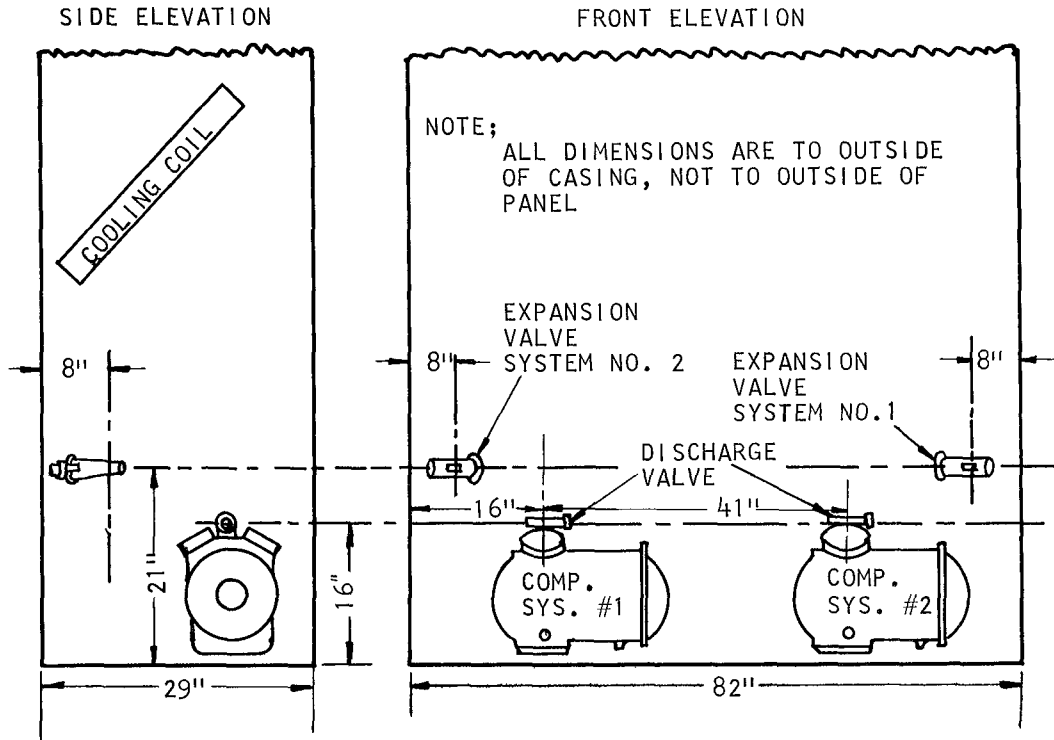

FIG. 4 - LOCATION OF COMPRESSOR DISCHARGE AND LIQUID CONNECTIONS  
50K16 - 2 COMPRESSOR MODEL

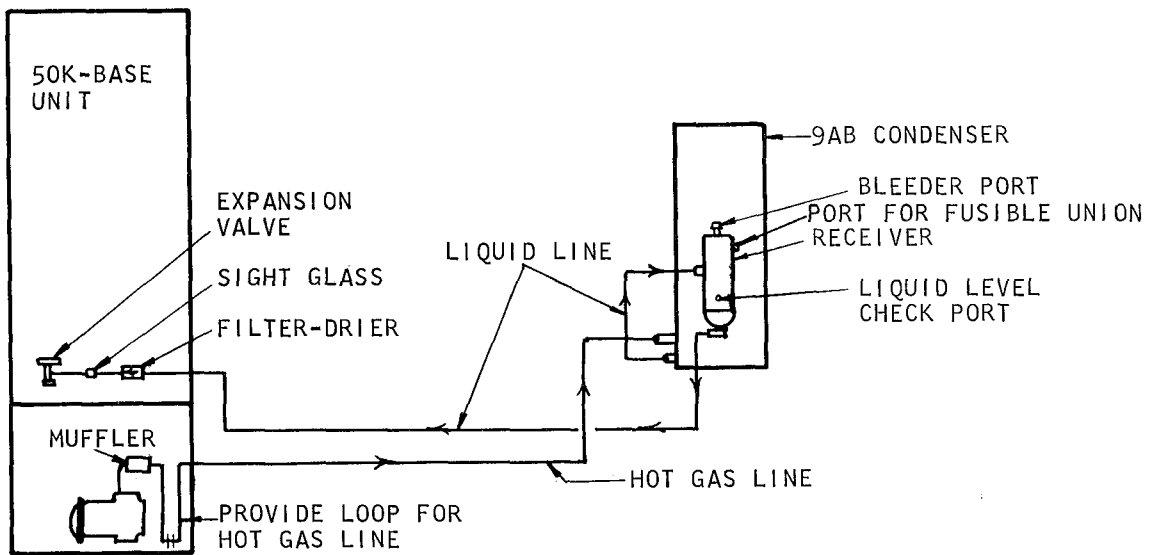
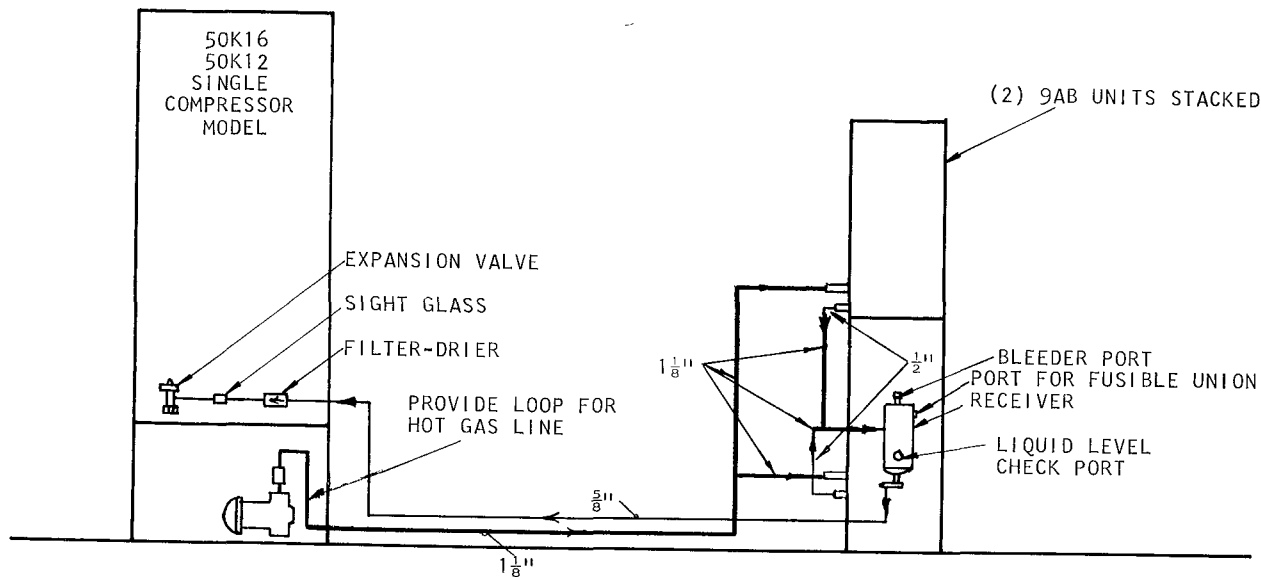

FIG. 5 - SCHEMATIC PIPING FOR 50K8 AND 50K12 WITH ONE (1) 9AB CONDENSER



NOTE: LINE SIZES SHOWN FOR 50 FT. EQUIV. LENGTH (SEE TABLE 3)

FIG. 6 - SCHEMATIC PIPING FOR 50K12 AND 50K16 SINGLE COMPRESSOR MODELS WITH (2) 9AB CONDENSERS

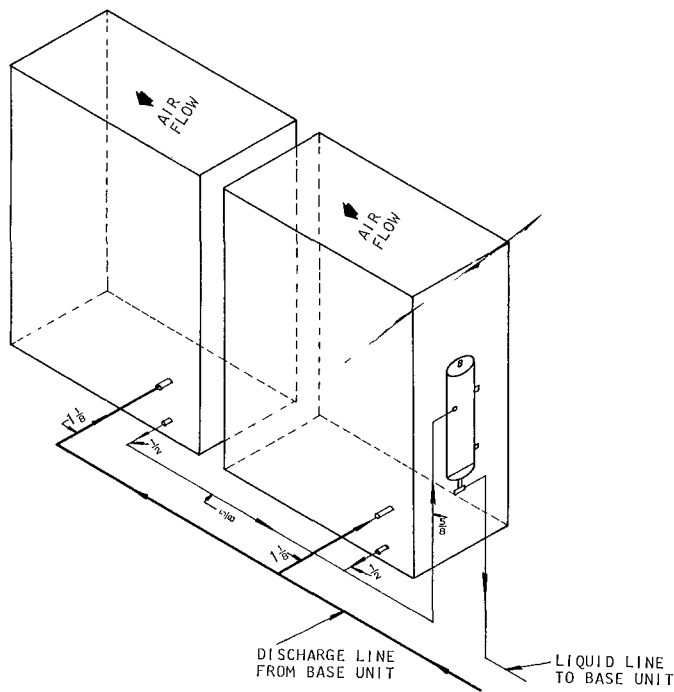

FIG. 6B - ALTERNATE ARRANGEMENT OF SCHEMATIC PIPING FOR 50K12 AND 50K16 SINGLE COMPRESSOR MODELS WITH (2) 9AB CONDENSERS

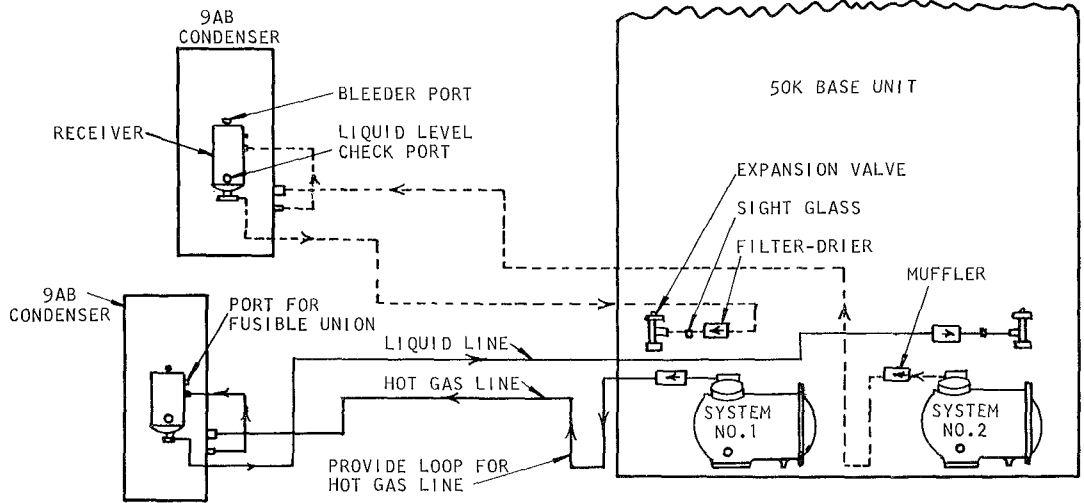

FIG. 7 - SCHEMATIC PIPING FOR 50K (2-COMPRESSORS) WITH TWO (2) 9AB CONDENSERS

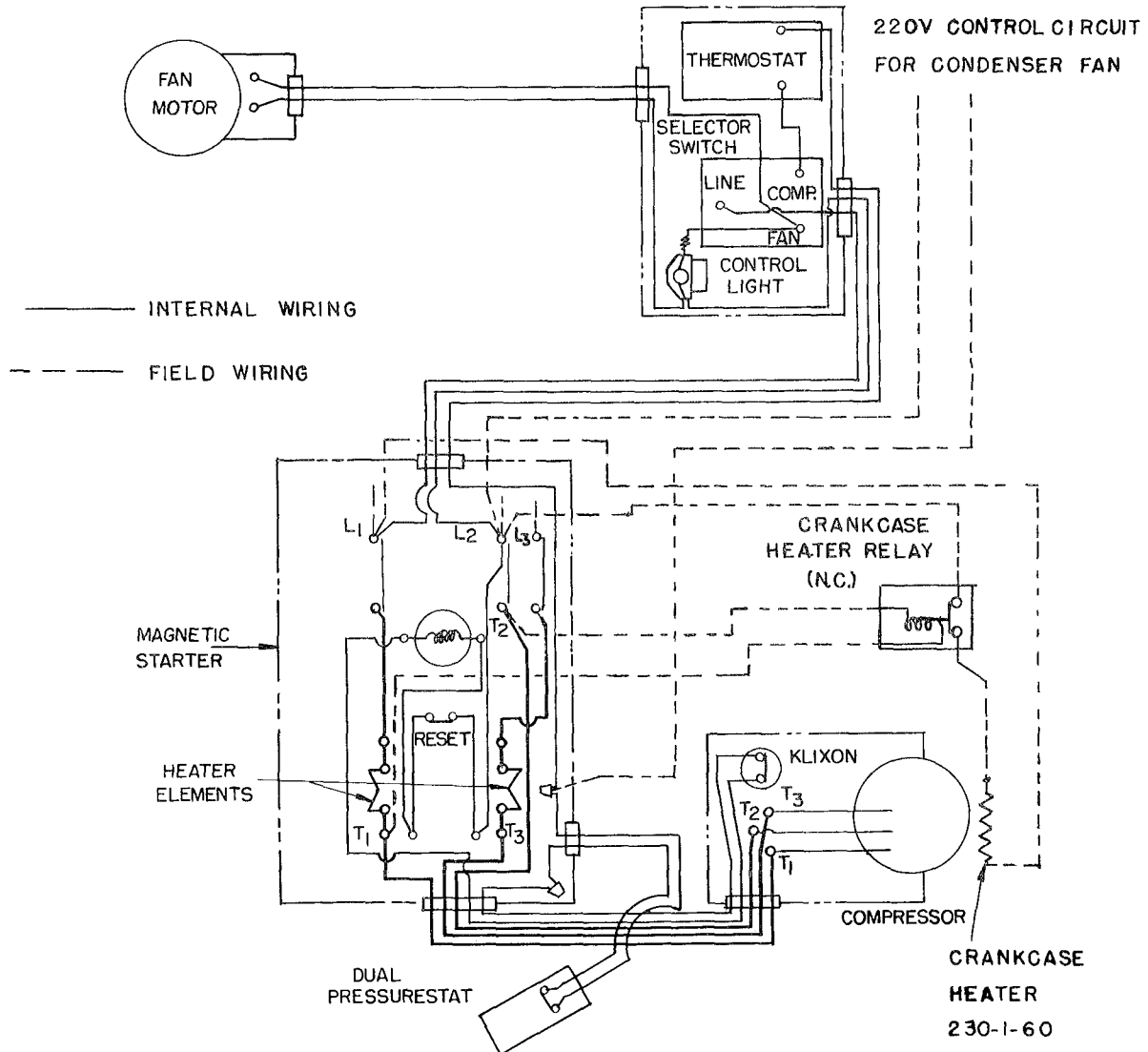

FIG. 8 - 50K8 (208/220-3-60) CONDENSERLESS



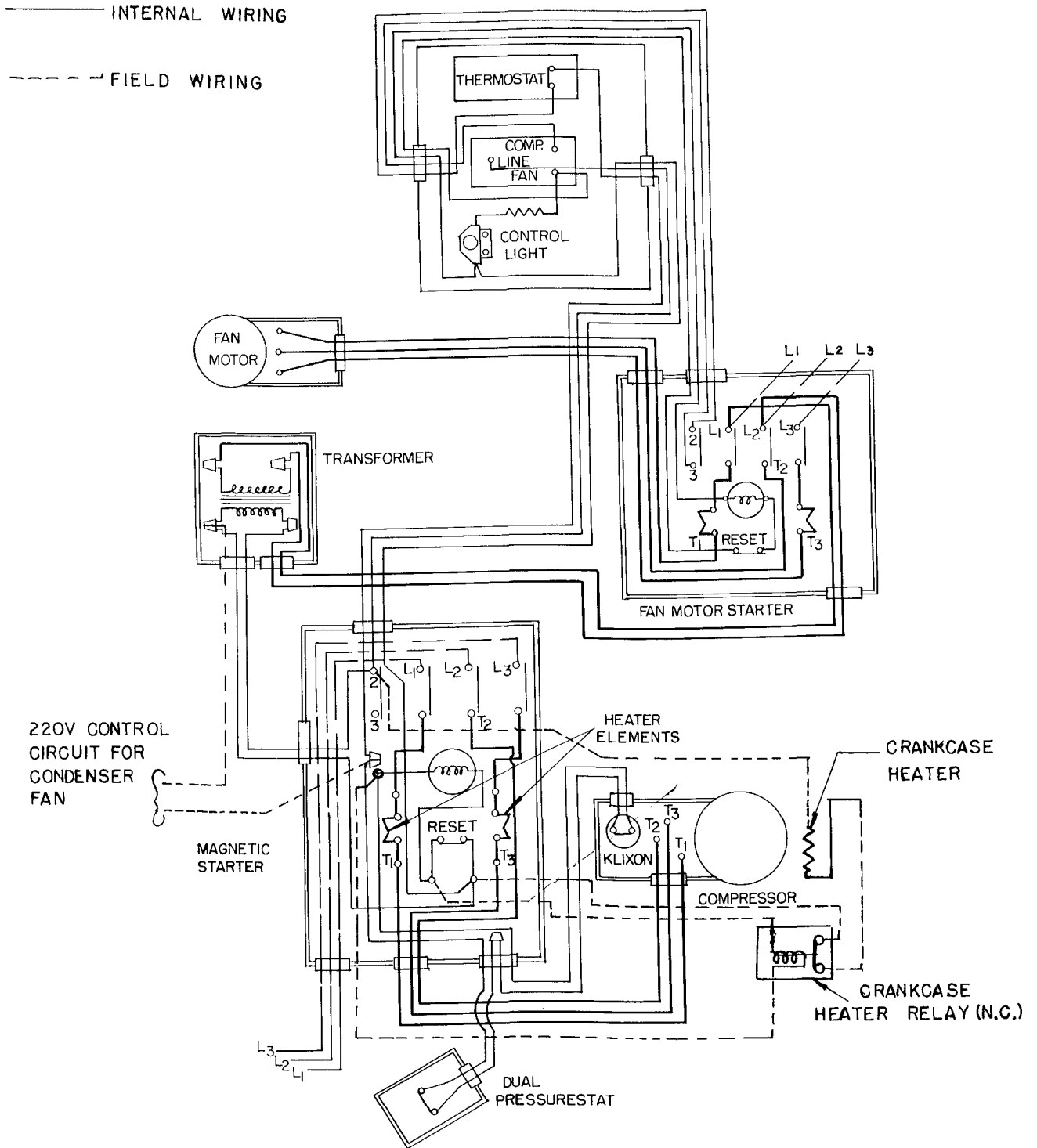

FIG. 9 - 50K8 (440/550-3-60) CONDENSERLESS

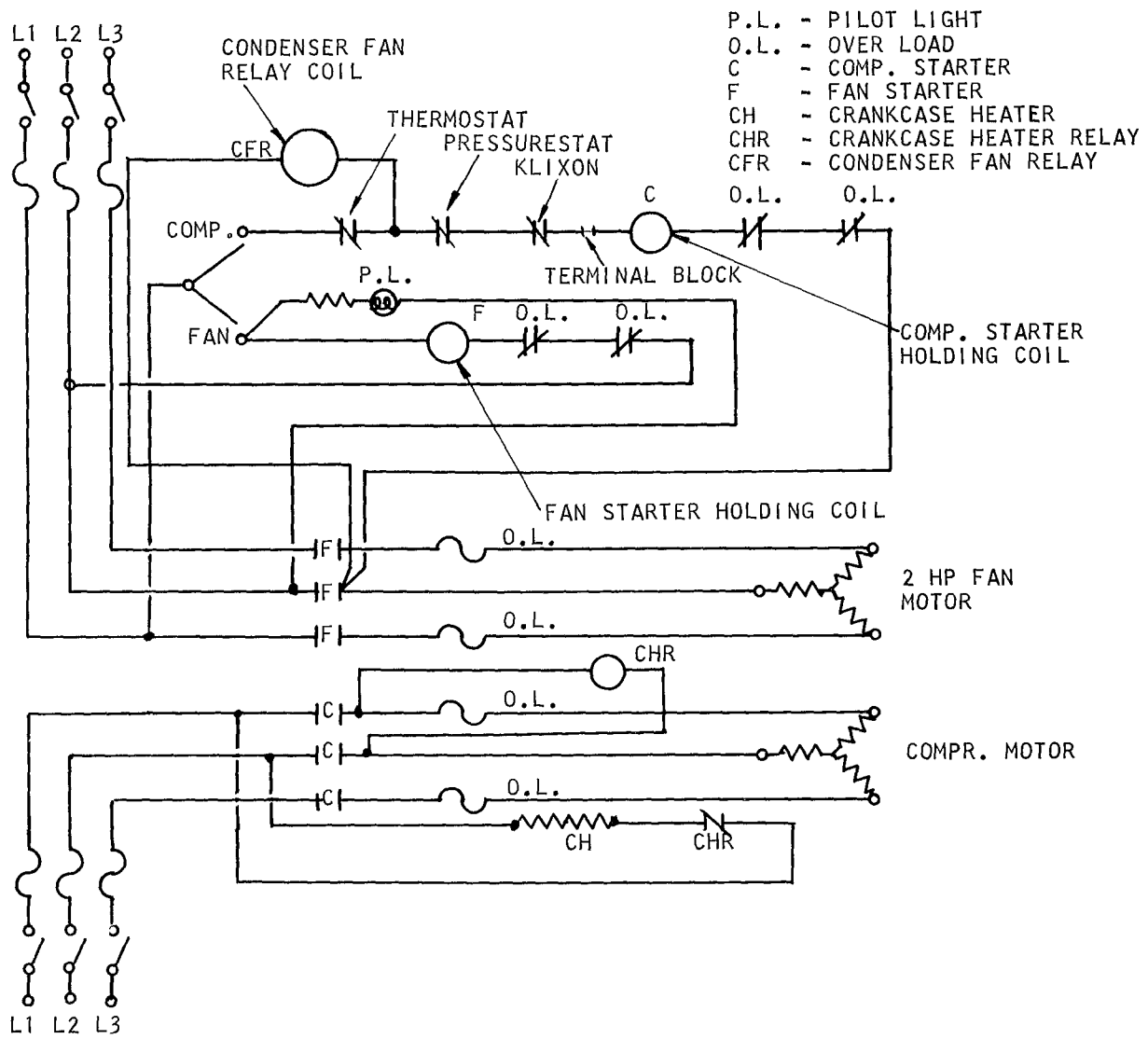

FIG. 10 - 50K12, SINGLE COMPRESSOR (208/230-3-60)  
 SCHEMATIC DIAGRAM, CONDENSERLESS

———— INTERNAL WIRING

----- FIELD WIRING

TO THERMOSTAT  
NOT FURNISHED  
BY CARRIER

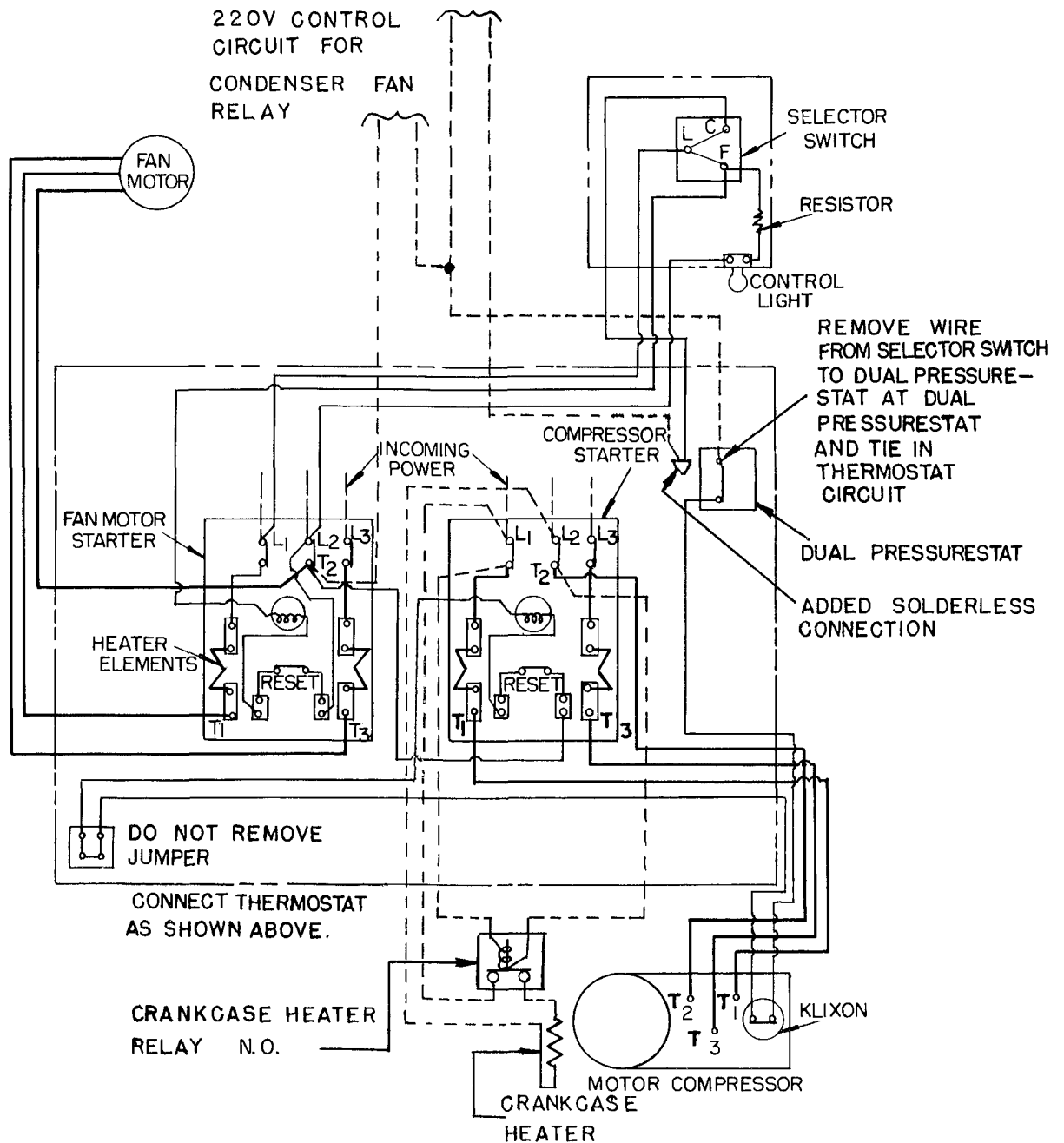

FIG. 11 - 50K12, SINGLE COMPRESSOR (208/220-3-60), CONDENSERLESS

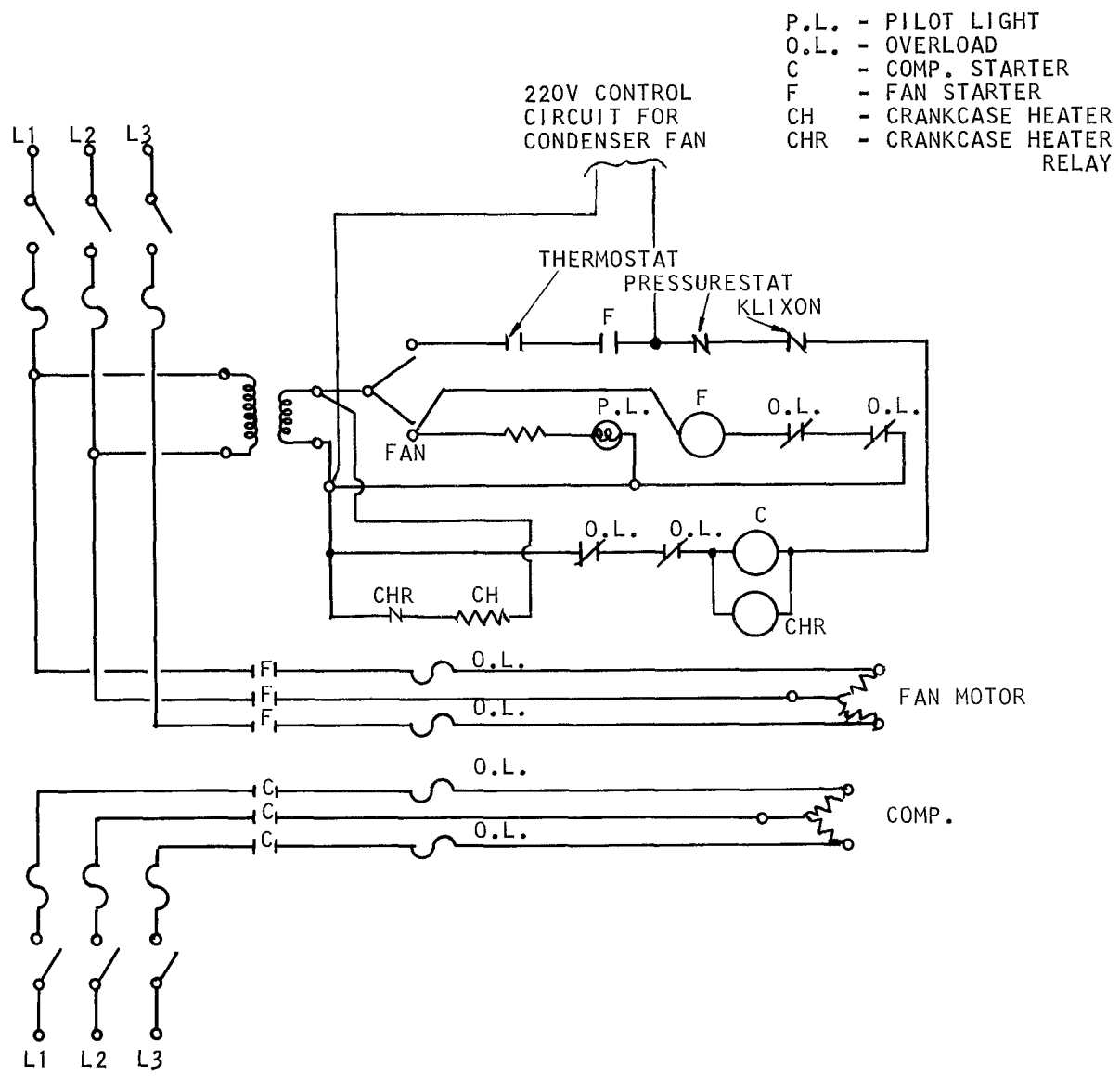

FIG. 12 - 50K12, SINGLE COMPRESSOR (440/550-3-60)  
SCHEMATIC DIAGRAM, CONDENSERLESS

———— INTERNAL WIRING

----- FIELD WIRING

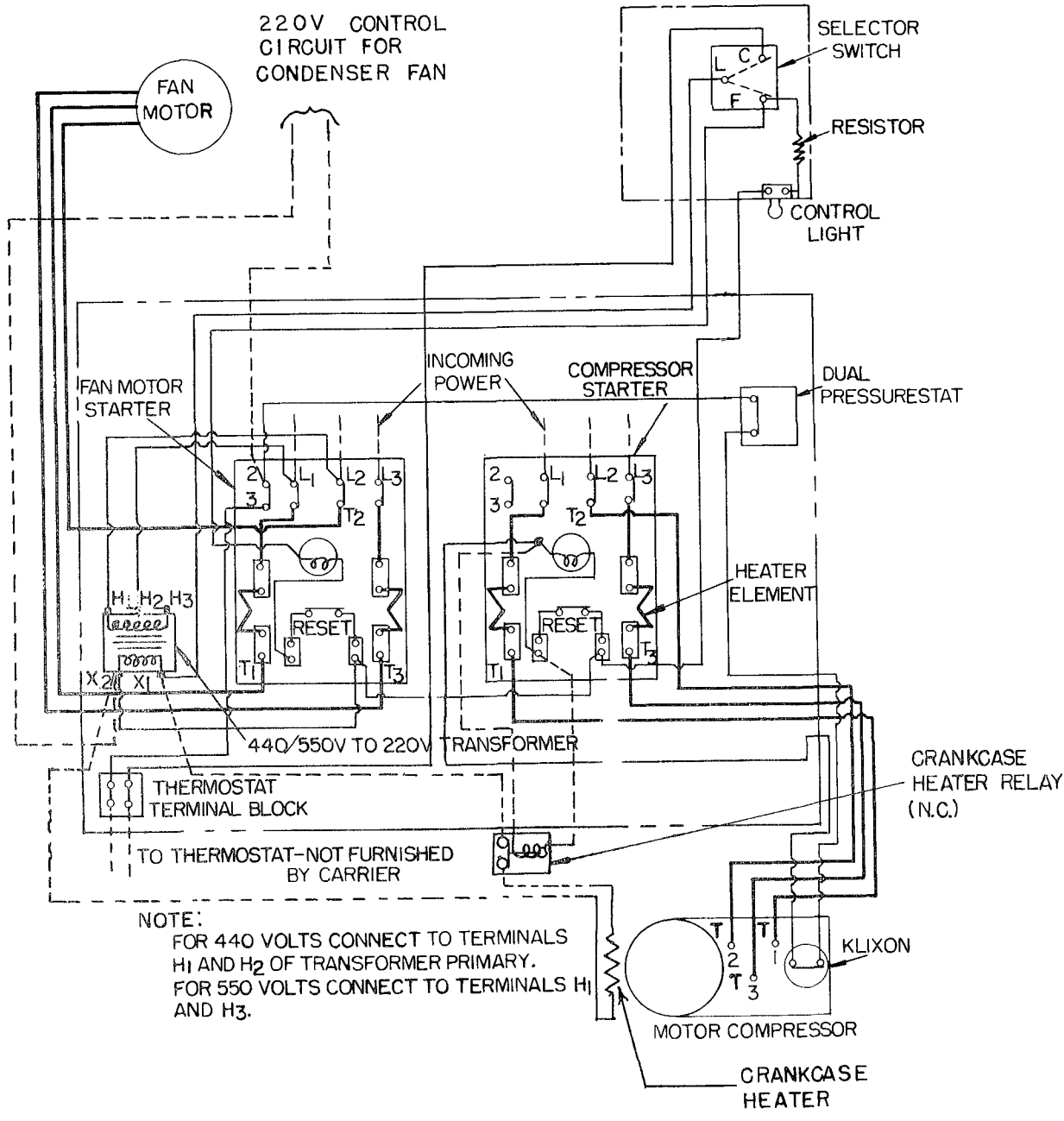

FIG. 13 - 50K12, SINGLE COMPRESSOR (440/550-3-60), CONDENSERLESS

———— INTERNAL WIRING

- - - - - FIELD WIRING

220V CONTROL CIRCUIT  
FOR CONDENSER FAN RELAY

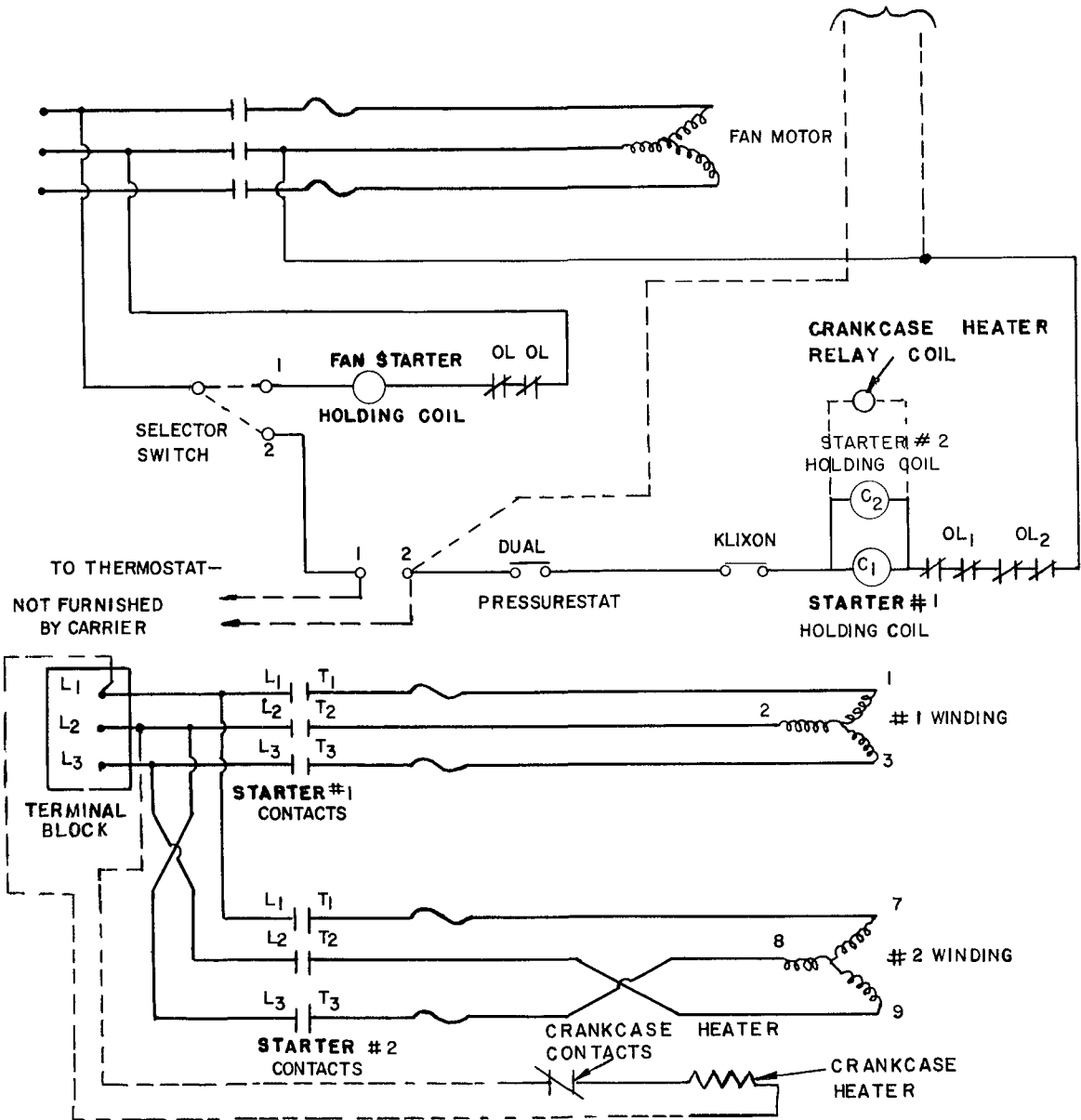

FIG. 14 - 50K16, SINGLE COMPRESSOR (208/220-3-60) SCHEMATIC DIAGRAM, CONDENSERLESS

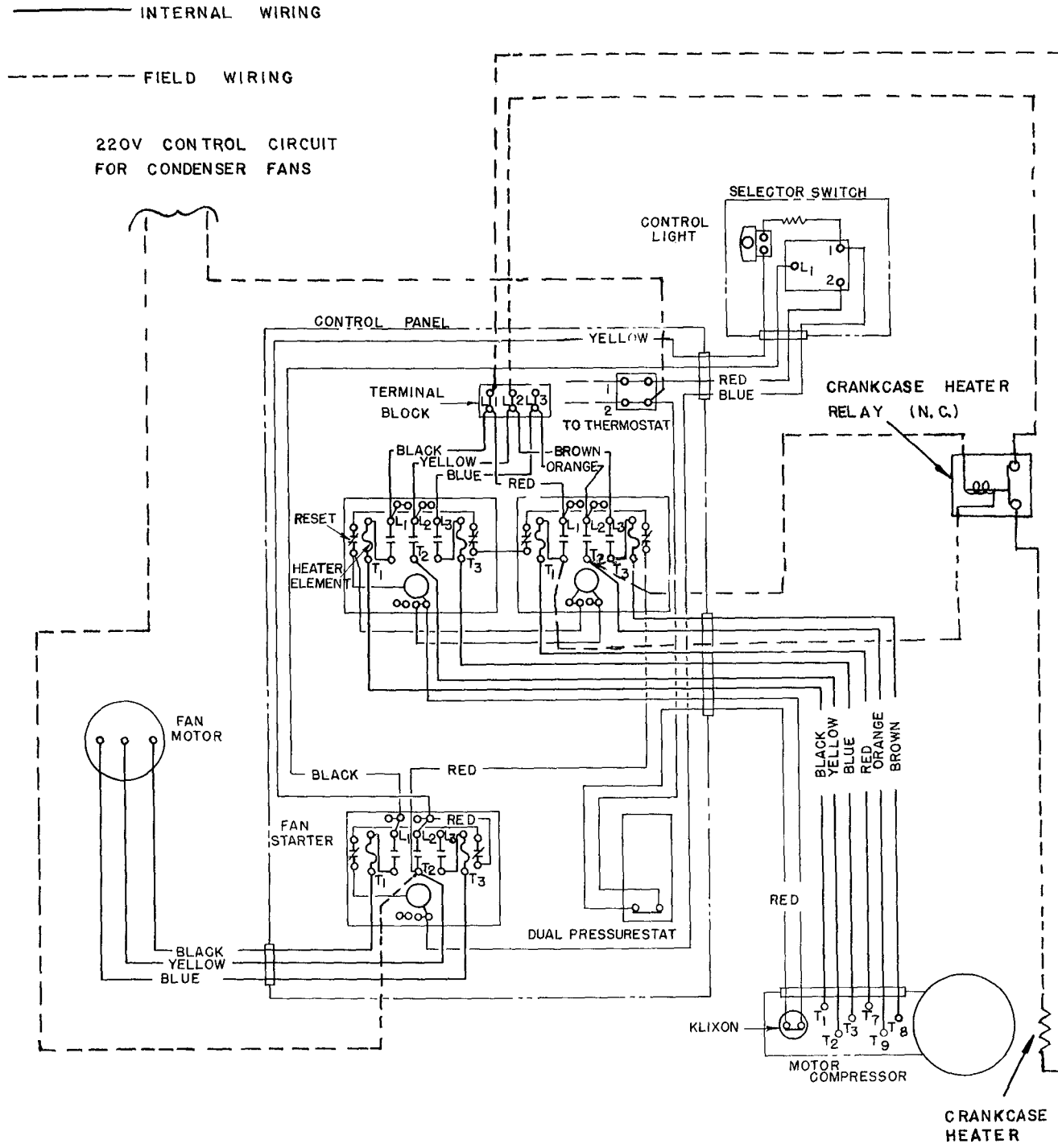

FIG. 15 - 50K16, SINGLE COMPRESSOR (208/220-3-60) CONDENSERLESS

———— INTERNAL WIRING

- - - - - FIELD WIRING

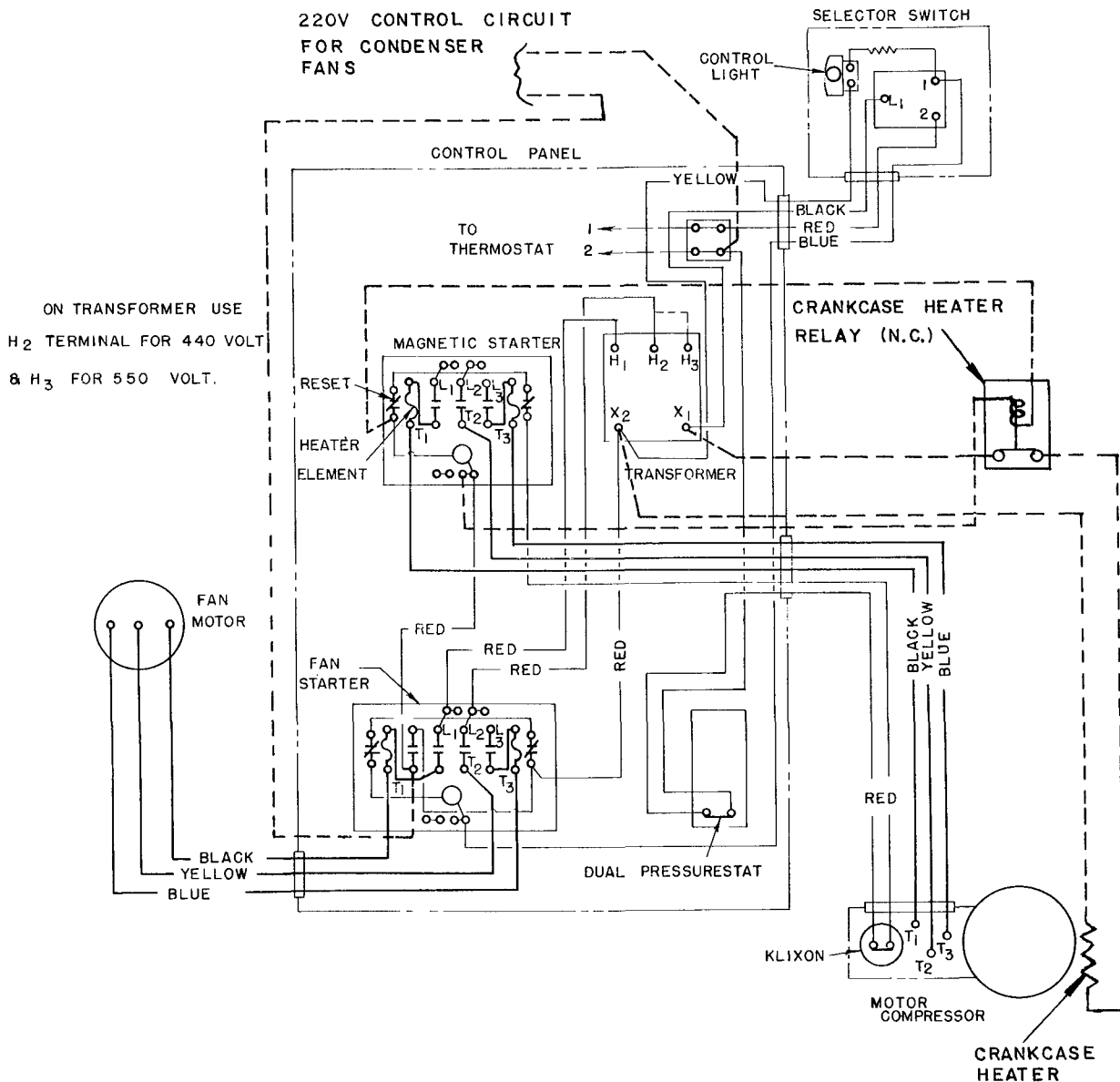

FIG. 16 - 50K16, SINGLE COMPRESSOR (440/550-3-60) CONDENSERLESS



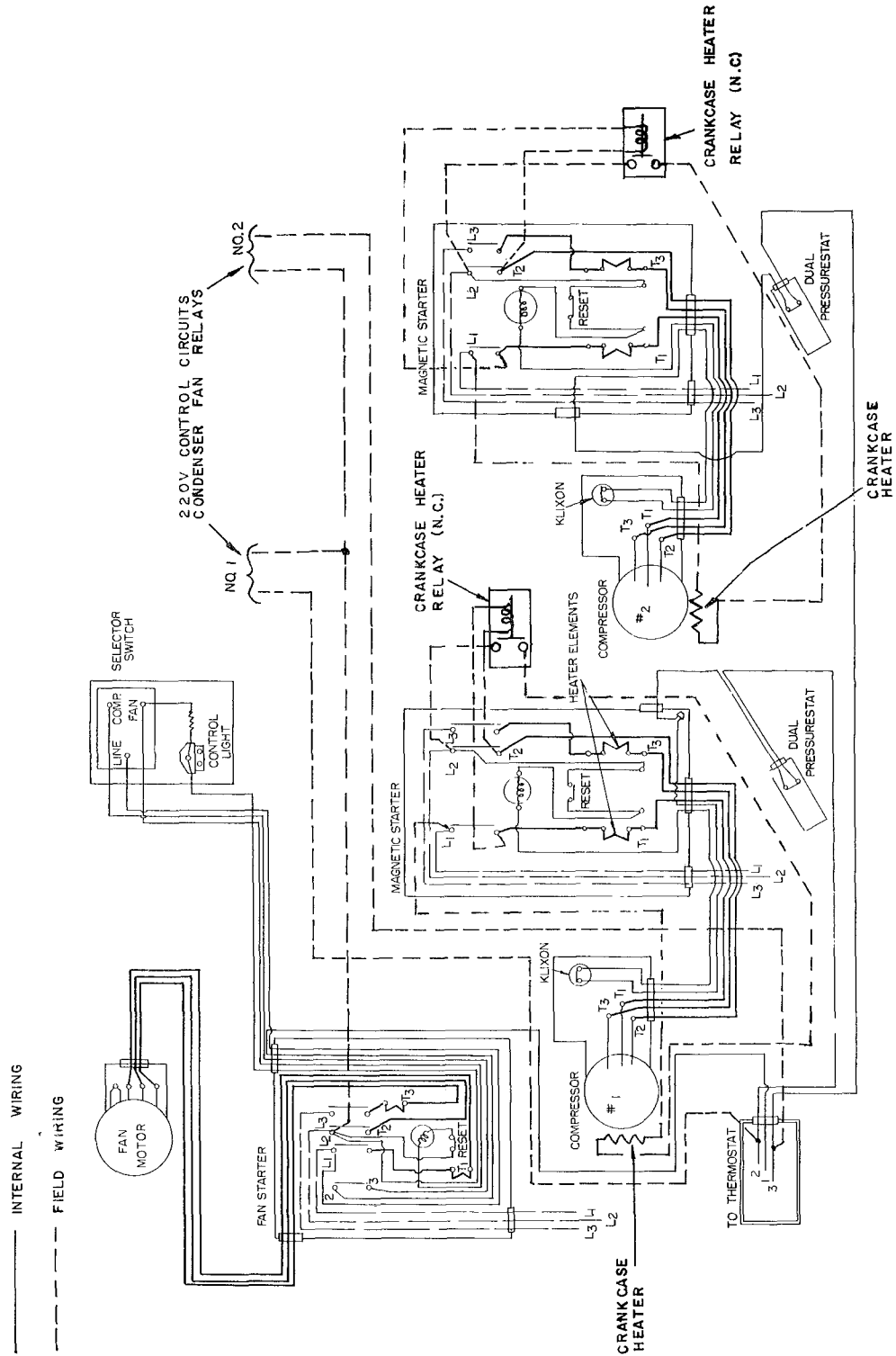

FIG 17 - 50K16, TWO COMPRESSOR (208/220-3-60) CONDENSERLESS

— INTERNAL WIRING  
 - - - FIELD WIRING

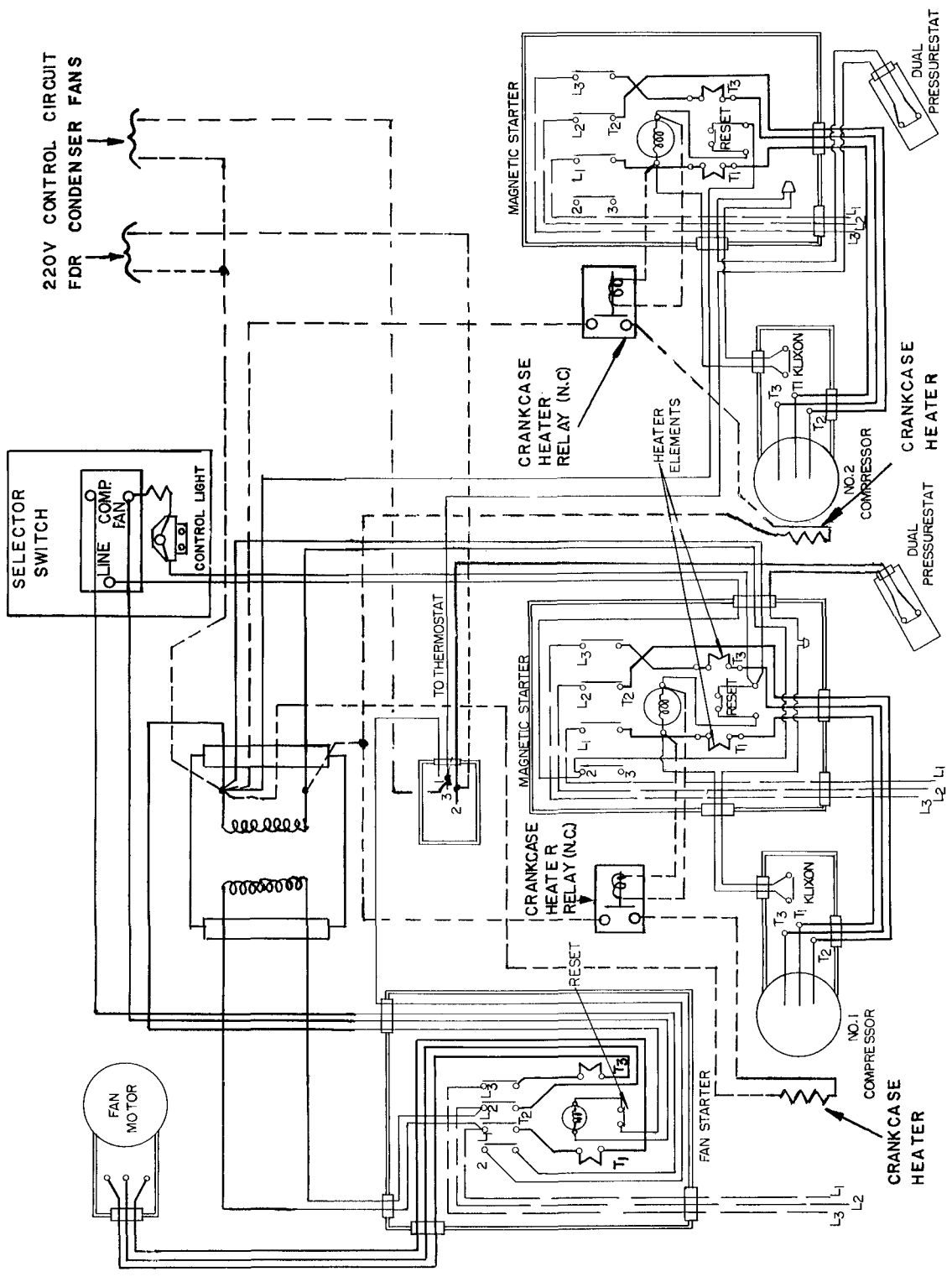

FIG. 18 - 50K16, TWO COMPRESSOR (440/550-3-60) CONDENSERLESS

FILING INSTRUCTIONS

BOOK (UED)	MAJOR TAB (UED)	MINOR TAB	THIS ISSUE	SUPERSEDES
Packaged Equipment (Installation and Service)	Packaged Units	Commercial and Industrial Units	50K8-1415 1-20 12-60	50K8-1405 1-18 9-59