



installation, start-up, and operating instructions

4-WAY MULTIPOISE FIXED-CAPACITY DIRECT-VENT CONDENSING GAS FURNACE

340MAV Series D

Cancels: II 340M-40-3 II 340M-40-4
12-96



A93040



APPROVALS
ISO 9001
EN 29001
BS 5750 PART 1
ANSI/ASQC Q91

As an ENERGY STARSM Partner, Bryant/Day & Night has determined that this product meets the ENERGY STAR guidelines for energy efficiency.

CERTIFICATE NO. FM 29652

CERTIFICATION OF MANUFACTURING SITE

NOTE: Read the entire instruction manual before starting the installation.

This symbol → indicates a change since the last issue.

Index	Page
DIMENSIONAL DRAWING.....	2
SAFETY CONSIDERATIONS.....	3
Clearances to Combustibles.....	3
ELECTROSTATIC DISCHARGE (ESD) PRECAUTIONS.....	3-4
INTRODUCTION.....	4
APPLICATIONS.....	4-11
General.....	4
Upflow Applications.....	4-7
Downflow Applications.....	7-8
Horizontal Left (Supply-Air Discharge) Applications.....	8-9
Horizontal Right (Supply-Air Discharge) Applications.....	9-11
LOCATION.....	11-12
General.....	11-12
Furnace Location Relative to Cooling Equipment.....	12
Hazardous Locations.....	12
INSTALLATION.....	13-17
Leveling Legs (If Desired).....	13
Installation In Upflow or Downflow Applications.....	13-15
Installation In Horizontal Applications.....	15
Filter Arrangement.....	16
Bottom Closure Panel.....	16
Gas Piping.....	17
ELECTRICAL CONNECTIONS.....	17-20
115-v Wiring.....	17-18
24-v Wiring.....	18
Wiring Diagram.....	19
Accessories.....	20
DIRECT VENTING.....	21-29
Removal of Existing Furnaces from	
Common Vent Systems.....	21
Combustion-Air and Vent Piping.....	21-27
Concentric Vent and Combustion-Air Termination	
Kit Installation.....	27-29
Multiventing and Vent Termination.....	29
CONDENSATE DRAIN.....	29-31
General.....	29
Application.....	29-31
Condensate Drain Protection.....	31

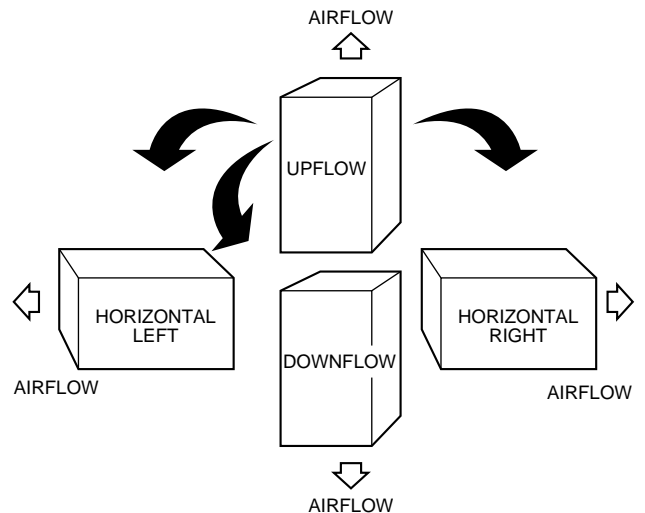
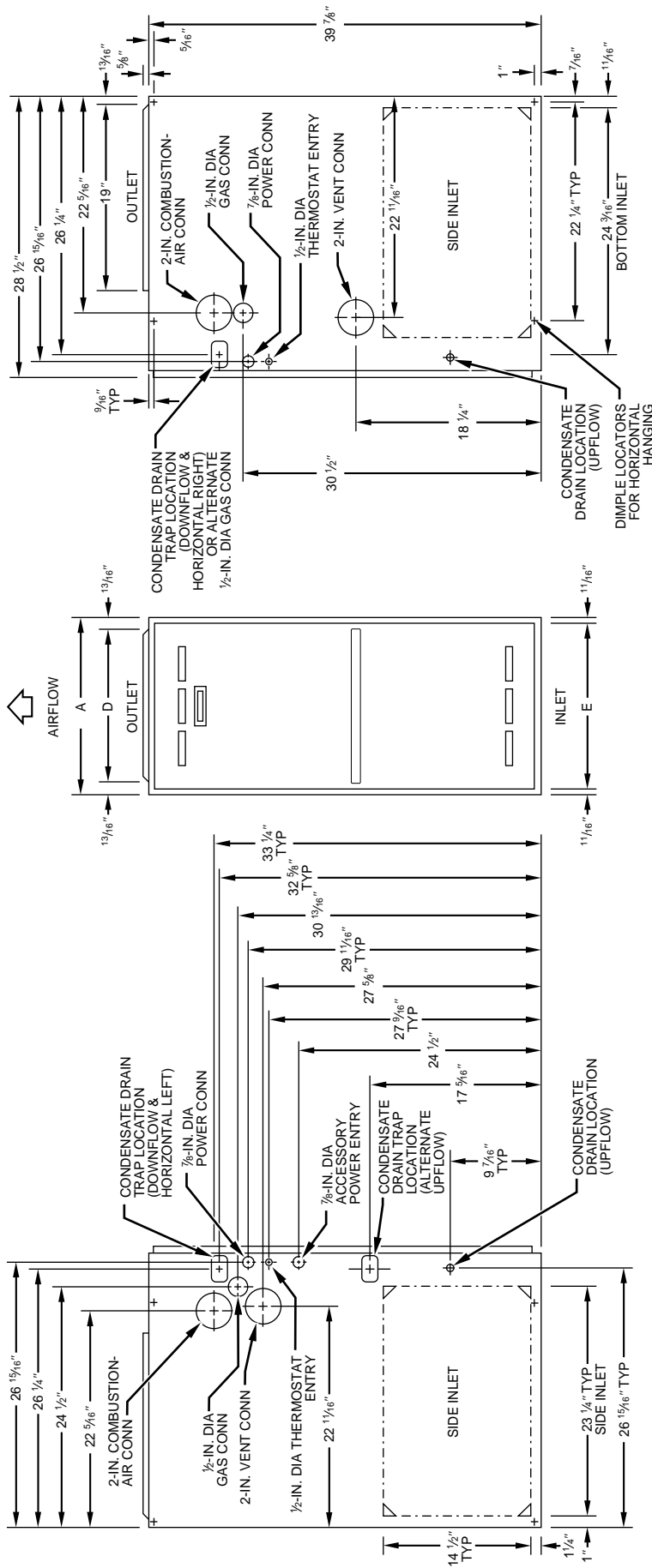

Fig. 1—Multipoise Orientations

A93041

SEQUENCE OF OPERATION.....	31-33
Heating Mode.....	31-32
Cooling Mode.....	32
Continuous Blower Mode.....	32
Heat Pump Mode.....	32
Component Test.....	32-33
START-UP PROCEDURES.....	33-41
General.....	33
Prime Condensate Trap With Water.....	33
Purge Gas Lines.....	34
Adjustments.....	34-41
Set Gas Input Rate.....	34-40
Set Temperature Rise.....	40-41
Blower Off Delay (Heat Mode).....	41
Set Thermostat Heat Anticipator.....	41
CHECK SAFETY CONTROLS.....	41
Check Primary Limit Control.....	41
Check Pressure Switch.....	41
CHECKLIST.....	41-42



- NOTES:** Minimum return-air opening at furnace:
1. For 800 CFM--16-in. round or 14 1/2 x 12-in. rectangle.
 2. For 1200 CFM--20-in. round or 14 1/2 x 19 1/2-in. rectangle.
 3. For 1600 CFM--22-in. round or 14 1/2 x 23 1/4-in. rectangle.
 4. For airflow requirements above 1800 CFM, use both side inlets, a combination of 1 side inlet and the bottom, or the bottom only.

DIMENSIONS (IN.)

UNIT SIZE	A	D	E
024040	17-1/2	15-7/8	16
036040	17-1/2	15-7/8	16
024060	17-1/2	15-7/8	16
036060	17-1/2	15-7/8	16
048060	17-1/2	15-7/8	16
036080	17-1/2	15-7/8	16
048080	17-1/2	15-7/8	16
060080	21	19-3/8	19-1/2
048100	21	19-3/8	19-1/2
060100	21	19-3/8	19-1/2
060120	24-1/2	22-7/8	23
→060140	24-1/2	22-7/8	23

Fig. 2—Dimensional Drawing

SAFETY CONSIDERATIONS

Installing and servicing heating equipment can be hazardous due to gas and electrical components. Only trained and qualified personnel should install, repair, or service heating equipment. Untrained personnel can perform basic maintenance functions such as cleaning and replacing air filters. All other operations must be performed by trained service personnel. When working on heating equipment, observe precautions in literature, on tags, and on labels attached to or shipped with unit and other safety precautions that may apply.

→ Follow all safety codes. In the United States, follow all safety codes including the National Fuel Gas Code (NFGC) NFPA No. 54-1996/ANSI Z223.1-1996 and the Installation Standards, Warm Air Heating and Air Conditioning Systems (NFPA 90B) ANSI/NFPA 90B. In Canada, refer to the current edition of the National Standard of Canada CAN/CGA-B149.1- and .2-M95 Natural Gas and Propane Installation Codes (NSCNGPIC). Wear safety glasses and work gloves. Have fire extinguisher available during start-up and adjustment procedures and service calls.

Recognize safety information. This is the safety-alert symbol . When you see this symbol on unit or in instructions and manuals, be alert to potential for personal injury.

Understand the signal words DANGER, WARNING, and CAUTION. These words are used with the safety-alert symbol. DANGER identifies most serious hazards which **will** result in severe personal injury or death. WARNING signifies hazards which **could** result in personal injury or death. CAUTION is used to identify unsafe practices which **would** result in minor personal injury or product and property damage. NOTE is used to highlight suggestions which **will** result in enhanced installation, reliability, or operation.

ELECTROSTATIC DISCHARGE (ESD) PRECAUTIONS

 **CAUTION:** Electrostatic discharge can affect electronic components. Take precautions during furnace installation and servicing to protect the furnace electronic control. Precautions will prevent electrostatic discharges from personnel and hand tools which are held during the procedure. These precautions will help to avoid exposing the control to electrostatic discharge by putting the furnace, the control, and the person at the same electrostatic potential.

1. Disconnect all power to the furnace. **DO NOT TOUCH THE CONTROL OR ANY WIRE CONNECTED TO THE CONTROL PRIOR TO DISCHARGING YOUR BODY'S ELECTROSTATIC CHARGE TO GROUND.**
2. Firmly touch a clean, unpainted, metal surface of the furnace chassis which is close to the control. Tools held in a person's hand during grounding will be satisfactorily discharged.
3. After touching the chassis you may proceed to service the control or connecting wires as long as you do nothing that recharges your body with static electricity (for example; **DO NOT** move or shuffle your feet, **DO NOT** touch ungrounded objects, etc.).
4. If you touch ungrounded objects (recharge your body with static electricity), firmly touch furnace again before touching control or wires.
5. Use this procedure for installed and uninstalled (ungrounded) furnaces.

This forced air furnace is equipped for use with natural gas at altitudes 0 - 10,000 ft (0 - 3,050m), except 140 size Furnaces are only approved for altitudes 0 - 7,000 ft. (0 - 2,135m).

An accessory kit, supplied by the manufacturer, shall be used to convert to propane gas use or may be required for some natural gas applications.

This direct-vent, forced-air furnace is for indoor installation in a building constructed on site or in a manufactured (mobile) home when using factory authorized kit, see rating plate.

This furnace may be installed on combustible flooring in alcove or closet at minimum clearance from combustible material.

This appliance requires a special venting system. Refer to the installation instructions for parts list and method of installation. This furnace is for use with schedule-40 PVC, PVC-DWV, or ABS-DWV pipe, and must not be vented in common with other gas-fired appliances. Construction through which vent/air intake pipes may be installed is maximum 24 inches (600 mm), minimum 3/4 inches (19 mm) thickness (including roofing materials).

MINIMUM INCHES CLEARANCE TO COMBUSTIBLE CONSTRUCTION

TOP / PLENUM	BOTTOM	SIDES	BACK	FRONT	VENT	INSTALLATION
1	0	0	0 ††	3*	0	UPFLOW
1	†	0	0 ††	3*	0	DOWNFLOW
1	0 ∅	1§	0 ††	3*	0	HORIZONTAL

† For Installation on combustible floors only when installed on special base No. KGASB0201ALL, Coil Assembly, Part No. CD5 or CK5, or Coil Casing, Part No. KCAKC.

§ Clearance shown is for air inlet and air outlet end.
Horizontal position: Line contact is permissible only between lines formed by intersections of top and two sides of furnace jacket, and building joists, studs, or framing.

∅ 120 and 140 size Furnaces require 1 inch bottom clearance to combustible materials.

* Minimum front clearance for service 30 inches (762mm).

†† 140 size Furnaces require 1 inch back clearance to combustible materials.

323855-101 REV. A (LIT)

→ Fig. 3—Clearances to Combustibles

6. Before removing a new control from its container, discharge your body's electrostatic charge to ground to protect the control from damage. If the control is to be installed in a furnace, follow items 1 through 5 before bringing the control or yourself into contact with the furnace. Put all used AND new controls into containers before touching ungrounded objects.
7. An ESD service kit (available from commercial sources) may also be used to prevent ESD damage.

INTRODUCTION

- The model 340MAV, Series D Furnaces are available in sizes 40,000 through 138,000 Btuh input capacities.
- The 340MAV Multipoise Condensing Gas-Fired Furnaces are A.G.A./C.G.A. design certified for natural and propane gases and for installation in alcoves, attics, basements, closets, utility rooms, crawlspaces, and garages. The furnace is factory-shipped for use with natural gas. An A.G.A./C.G.A. listed gas conversion kit is required to convert furnace for use with propane gas. The 340MAV 040 through 120 size units are A.G.A./C.G.A. approved for use in manufactured (mobile) homes when factory accessory conversion kit is used. The 140 size unit is not approved for use in manufactured (mobile) homes. These furnaces are suitable for installation in a residence built on site or a manufactured residence completed at final site. The design of this furnace line is NOT A.G.A./C.G.A. certified for installation in recreation vehicles or outdoors.
- These furnaces SHALL NOT be installed directly on carpeting, tile, or any other combustible material other than wood flooring. In downflow installations, factory accessory floor base MUST be used when installed on combustible materials and wood flooring. Special base is not required when this furnace is installed on manufacturer's Coil Assembly Part No. CD5 or CK5, or when Coil Box Part No. KCAKC is used.

These furnaces are shipped with the drain and pressure tubes connected for UPFLOW applications. Minor modifications are required when used in DOWNFLOW, HORIZONTAL RIGHT, or HORIZONTAL LEFT (supply-air discharge direction) applications as shown in Fig. 1. See details in Applications section.

These furnaces are shipped with the following materials to assist in proper furnace installation. These materials are shipped in the main blower compartment.

Installer Packet includes:

- Installation, Start-Up, and Operating Instructions
- Service and Maintenance Procedures
- User's Information Manual
- Warranty Certificate

Loose Parts Bag includes:	Quantity
Pressure tube extension	1
Collector box or condensate trap extension tube	1
Inducer housing drain tube	1
1/2-in. CPVC street elbow	2
Drain tube coupling	1
Drain tube coupling grommet	1
Vent and combustion-air pipe support	2
Combustion-air pipe perforated disk assembly	1
Vent Pipe Extension	1*

* ONLY supplied with some furnaces.

Before installing the furnace in the United States, refer to the current edition of the NFGC and the NFPA 90B. For further information, the NFGC and the NFPA 90B are available from National Fire Protection Association Inc., Batterymarch Park, Quincy, MA 02269; American Gas Association, 1515 Wilson Boulevard, Arlington, VA 22209; or from Literature Distribution. Before installing the furnace in Canada, refer to the current edition of the NSCNPIC. Contact Standards Department of Canadian Gas Association, 55 Scarsdale Road, Don Mills, Ontario, Canada M3B 2R3.

Installations must comply with regulations of serving gas supplier and local building, heating, plumbing, or other codes in effect in area in which installation is made. In absence of local codes, installation must conform with NFGC.

Canadian installations must be made in accordance with NSCNPIC and all authorities having jurisdiction.

These instructions cover minimum requirements for a safe installation and conform to existing national standards and safety codes. In some instances, these instructions exceed certain local codes and ordinances, especially those that may not have kept pace with changing residential construction practices. We require these instructions as a minimum for a safe installation.

CAUTION: Application of this furnace should be indoors with special attention given to vent sizing and material, gas input rate, air temperature rise, unit leveling, and unit sizing. Improper installation or misapplication of furnace can require excessive servicing or cause premature component failure.

WARNING: Improper installation, adjustment, alteration, service, maintenance, or use can cause carbon monoxide poisoning, explosion, fire, electrical shock, or other conditions which may cause personal injury or property damage. Consult a qualified installer, service agency, local gas supplier, or your distributor or branch for information or assistance. The qualified installer or agency must use only factory-authorized and listed kits or accessories when modifying this product. Failure to follow this warning could result in electrical shock, fire, personal injury, or death.

For accessory installation details, refer to applicable installation literature.

APPLICATIONS

I. GENERAL

Some assembly and modifications are required for furnaces installed in any of the 4 applications shown in Fig. 1. All drain and pressure tubes are connected as shown in Fig. 5. See appropriate application instructions for these procedures.

II. UPFLOW APPLICATIONS

An upflow furnace application is where furnace blower is located below combustion and controls section of furnace, and conditioned air is discharged upwards.

A. Condensate Trap Location (Factory-Shipped Orientation)

The condensate trap is factory installed in the blower shelf and factory connected for UPFLOW applications. A factory-supplied tube is used to extend the condensate trap drain connection to the desired furnace side for field drain attachment. See Condensate Trap Tubing (Factory-Shipped Orientation) section for drain tube extension details.

B. Condensate Trap Tubing (Factory-Shipped Orientation)

NOTE: See Fig. 5 or tube routing label on main furnace door to confirm location of these tubes.

1. Collector Box Drain, Inducer Housing Drain, Relief Port, and Pressure Switch Tubes

These tubes should be factory attached to condensate trap and pressure switch ready for use in UPFLOW applications. These tubes can be identified by their connection location

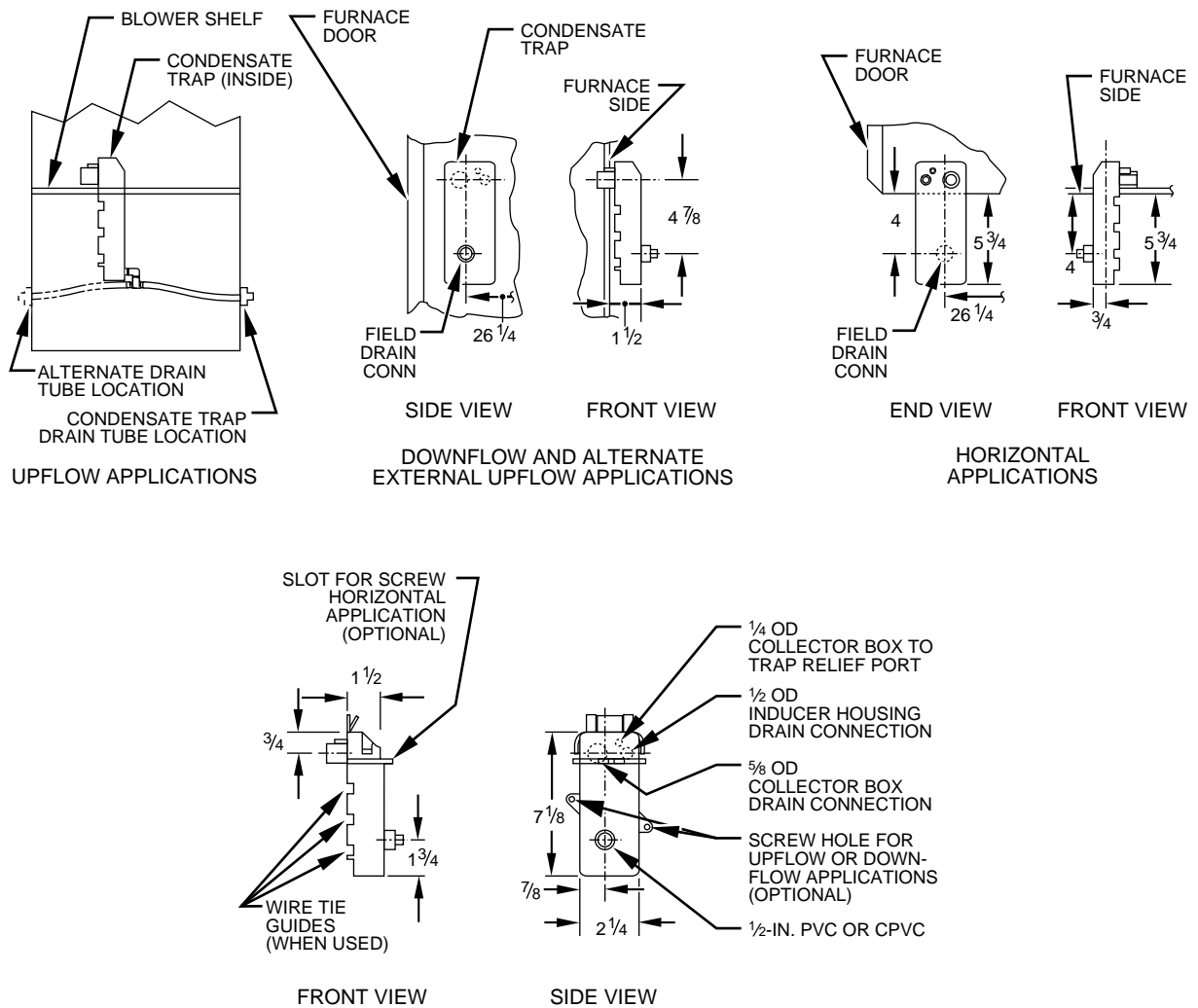

Fig. 4—Condensate Trap

A93026

and also by a color label on each tube. These tubes are identified as follows: collector box drain tube (blue label), inducer housing drain tube (violet label or molded), relief port tube (green label), and pressure switch tube (pink label).

2. Condensate Trap Drain Tube

The condensate trap drain connection must be extended for field attachment by doing the following:

- Determine location of field drain connection. (See Fig. 2 or 5.)

NOTE: If internal filter is used, drain tube should be located to opposite side of casing of return duct attachment to assist in filter removal.

- Remove and discard casing drain hole plug button from desired side.
- Install drain tube coupling grommet (factory-supplied in loose parts bag) in selected casing hole.
- Slide drain tube coupling (factory-supplied in loose parts bag) through grommet ensuring long end of coupling faces blower.
- Cement 2 factory-supplied 1/2-in. street CPVC elbows to the rigid drain tube connection on the condensate trap. (See Fig. 5.) These elbows must be cemented together and cemented to condensate trap drain connection.

NOTE: Failure to use CPVC elbows may allow drain to kink and prevent draining.

- Connect larger diameter drain tube and clamp (factory-supplied in loose parts bag) to condensate trap and clamp securely.
- Route tube to coupling and cut to appropriate length.
- Attach tube to coupling and clamp securely.

C. Condensate Trap Location (Alternate Upflow Orientation)

An alternate location for the condensate trap is the left-hand side of casing. (See Fig. 2 and 6.)

NOTE: If the alternate left-hand side of casing location is used, the factory-connected drain and relief port tubes must be disconnected and modified for attachment. See Condensate Trap Tubing (Alternate Upflow Orientation) section for tubing attachment.

To relocate condensate trap to the left-hand side, perform the following:

- Remove 3 tubes connected to condensate trap.
- Remove trap from blower shelf by gently pushing tabs inward and rotating trap.
- Remove casing hole filler cap from casing hole. (See Fig. 2 or 6.)
- Install casing hole filler cap into blower shelf hole where trap was removed.
- Install condensate trap into left-hand side casing hole by inserting tube connection stubs through casing hole and rotating until tabs snap into locking position.

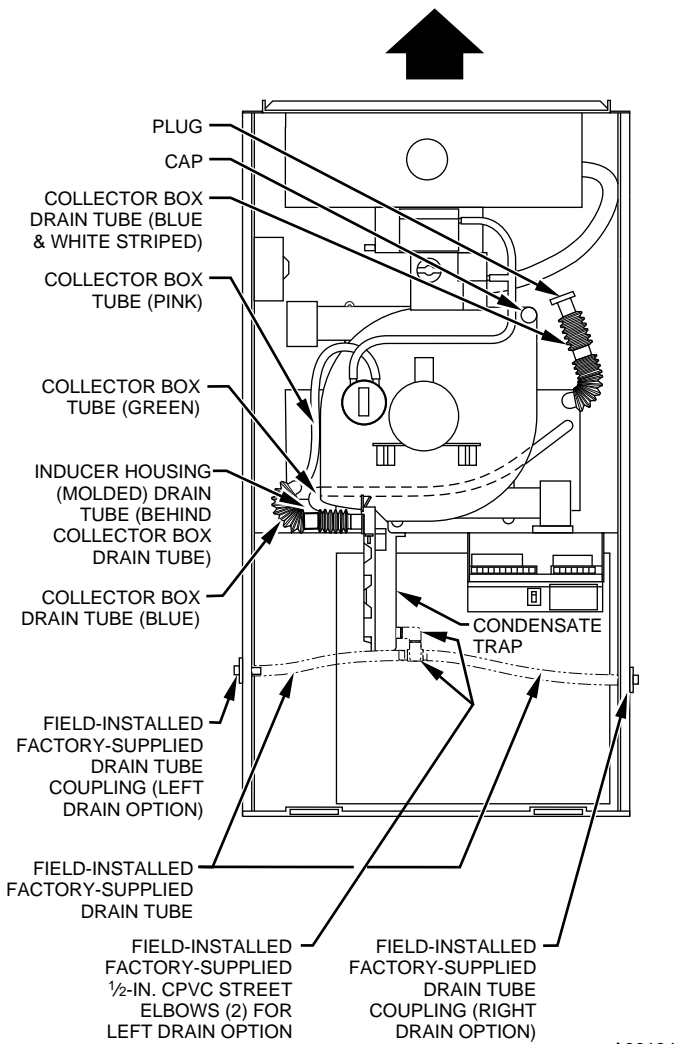

Fig. 5—Factory-Shipped Upflow Tube Configuration (Shown With Blower Access Panel Removed)

D. Condensate Trap Tubing (Alternate Upflow Orientation)

NOTE: See Fig. 6 or tube routing label on main furnace door to confirm location of these tubes.

1. Collector Box Drain Tube

Connect collector box drain tube (blue label) to condensate trap.

NOTE: On 17-1/2-in. wide furnaces ONLY, cut tube between corrugated sections to prevent kinks from occurring.

2. Inducer Housing Drain Tube

a. Remove and discard LOWER (molded) inducer housing drain tube which was previously connected to condensate trap.

b. Use inducer housing drain extension tube (violet label and factory-supplied in loose parts bag) to connect LOWER inducer housing drain connection to the condensate trap.

c. Determine appropriate length, cut, and connect tube.

d. Clamp tube to prevent any condensate leakage.

3. Relief Port Tube

a. Connect relief port tube (green label) to condensate trap.

b. Extend this tube (if required) by splicing to small diameter tube (factory-supplied in loose parts bag).

c. Determine appropriate length, cut, and connect tube.

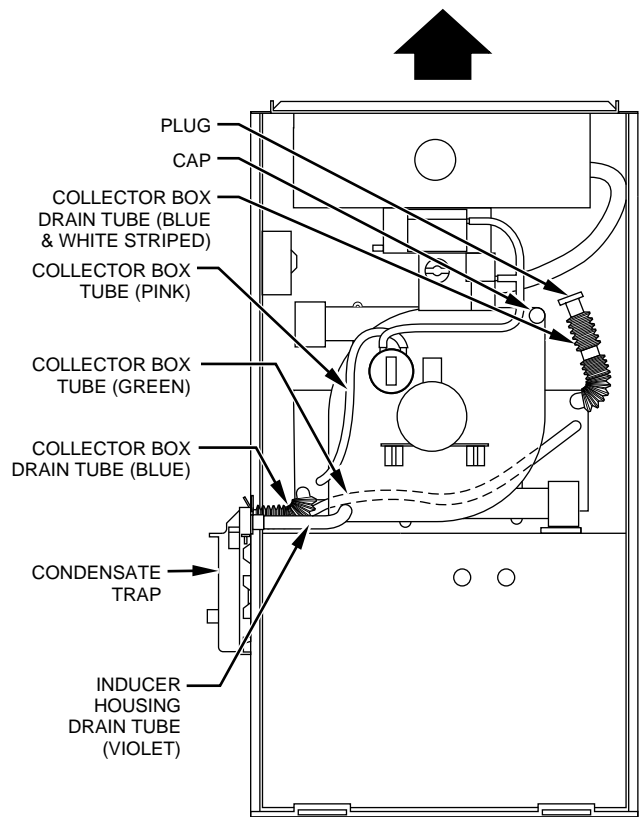

Fig. 6—Alternate Upflow Tube Configuration and Trap Location

E. Condensate Trap Field Drain Attachment

Refer to Condensate Drain section for recommendations and procedures.

F. Pressure Switch Tubing

The LOWER collector box pressure tube (pink label) is factory connected to the pressure switch and should not require any modification.

NOTE: See Fig. 5 or 6 or tube routing label on main furnace door to check for proper connections.

G. Upper Collector Box and Inducer Housing (Unused) Drain Connections

UPPER COLLECTOR BOX DRAIN CONNECTION

Attached to the UPPER collector box drain connection is a factory-installed corrugated, plugged tube (blue and white striped label). This tube is plugged to prevent condensate leakage in this application. Ensure this tube is plugged.

NOTE: See Fig. 5 or 6 or tube routing label on main furnace door to check for proper connections.

UPPER INDUCER HOUSING DRAIN CONNECTION

Attached to the UPPER (unused) inducer housing drain connection is a cap and clamp. This cap is used to prevent condensate leakage in this application. Ensure this connection is capped.

NOTE: See Fig. 5 or 6 or tube routing label on main furnace door to check for proper connections.

A96194

A96195

H. Condensate Trap Freeze Protection

Refer to Condensate Drain Protection section for recommendations and procedures.

III. DOWNFLOW APPLICATIONS

A downflow furnace application is where furnace blower is located above combustion and controls section of furnace, and conditioned air is discharged downwards.

A. Condensate Trap Location

The condensate trap must be removed from the factory-installed blower shelf location and relocated in selected application location as shown in Fig. 2, 7, or 8.

To relocate condensate trap from the blower shelf to desired location, perform the following:

1. Remove 3 tubes connected to condensate trap.
2. Remove trap from blower shelf by gently pushing tabs inward and rotating trap.
3. Remove casing hole filler cap from casing hole. (See Fig. 2, 7, or 8.)
4. Install casing hole filler cap into blower shelf hole where trap was removed.
5. Install condensate trap into desired casing hole by inserting tube connection stubs through casing hole and rotating until tabs snap into locking position.

B. Condensate Trap Tubing

NOTE: See Fig. 7 or 8 or tube routing label on main furnace door to check for proper connections.

1. Collector Box Drain Tube
 - a. Remove factory-installed plug from LOWER collector box drain tube (blue and white striped label).
 - b. Install removed clamp and plug into UPPER collector box drain tube (blue label) which was connected to condensate trap.

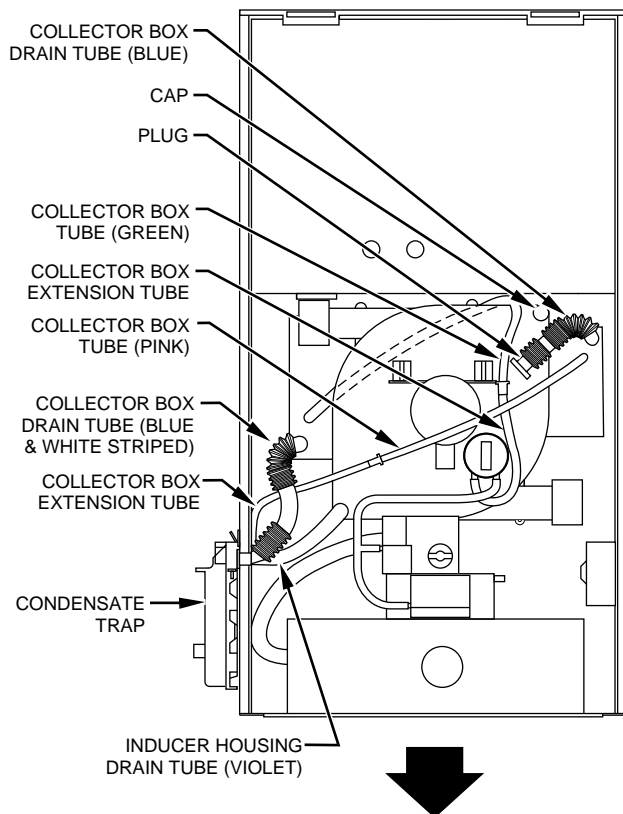

Fig. 7—Downflow Tube Configuration (Left-Hand Trap Installation)

A96196

- c. Connect LOWER collector box drain connection to condensate trap.

- (1.) Condensate Trap Located on Left Side of Casing
 - (a.) Connect LOWER collector box drain tube (blue and white striped label) to condensate trap. Tube does not need to be cut.
 - (b.) Clamp tube to prevent any condensate leakage.
- (2.) Condensate Trap Located on Right Side of Casing
 - (a.) Install drain tube coupling (factory-supplied in loose parts bag) into collector box drain tube (blue and white striped label) which was previously plugged.
 - (b.) Connect larger diameter drain tube (factory-supplied in loose parts bag) to drain tube coupling, extending collector box drain tube for connection to condensate trap.
 - (c.) Route extended collector box drain tube directly from collector box drain to condensate trap as shown in Fig. 8.
 - (d.) Determine appropriate length and cut.
 - (e.) Connect to condensate trap.
 - (f.) Clamp tube to prevent any condensate leakage.

→

2. Inducer Housing Drain Tube

- a. Remove factory-installed cap and clamp from LOWER inducer housing drain connection.
- b. Remove and discard UPPER (molded) inducer housing drain tube which was previously connected to condensate trap.
- c. Install cap and clamp on UPPER inducer housing drain connection where molded drain tube was removed.

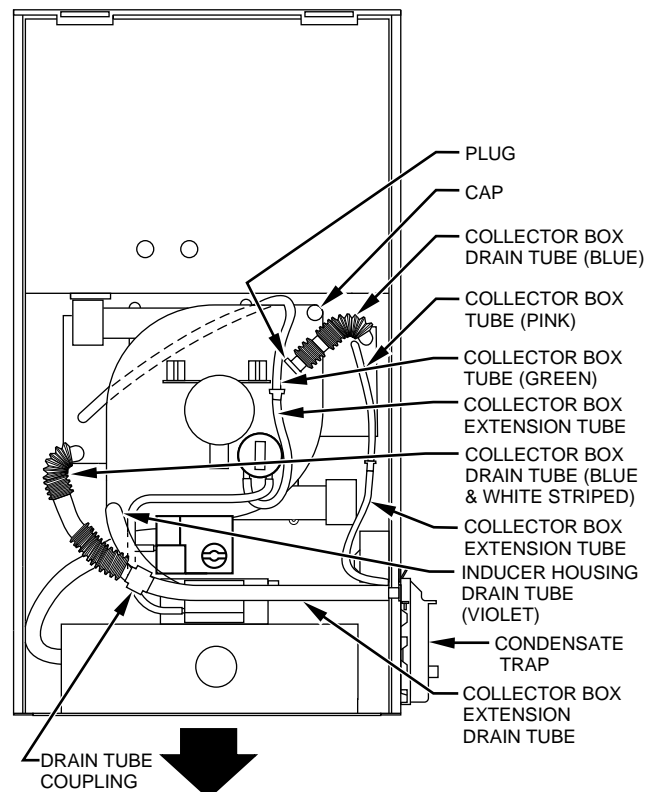

Fig. 8—Downflow Tube Configuration (Right-Hand Trap Installation)

A96197

- d. Use inducer housing drain tube (violet label and factory-supplied in loose parts bag) to connect LOWER inducer housing drain connection to the condensate trap.
 - e. Connect inducer housing drain connection to condensate trap.
 - (1.) Condensate Trap Located on Left Side of Casing
 - (a.) Determine appropriate length and cut.
 - (b.) Connect tube to condensate trap.
 - (c.) Clamp tube to prevent any condensate leakage.
 - (2.) Condensate Trap Located on Right Side of Casing
 - (a.) Route inducer housing drain tube (violet label) directly from inducer housing to condensate trap as shown in Fig. 8.
 - (b.) Determine appropriate length and cut.
 - (c.) Connect tube to condensate trap.
 - (d.) Clamp tube to prevent any condensate leakage.
3. Relief Port Tube

Refer to Pressure Switch Tubing section for connection procedure.

C. Condensate Trap Field Drain Attachment

Refer to Condensate Drain section for recommendations and procedures.

D. Pressure Switch Tubing

One collector box pressure tube (pink label) is factory connected to the pressure switch for use when furnace is installed in UPFLOW applications. This tube MUST be disconnected and used for the condensate trap relief port tube. The other collector box pressure tube (green label) which was factory connected to the condensate trap relief port connection MUST be connected to the pressure switch in DOWNFLOW or HORIZONTAL RIGHT applications.

NOTE: See Fig. 7 or 8 or tube routing label on main furnace door to check for proper connections.

Relocate tubes as described below.

- 1. Disconnect collector box pressure tube (pink label) attached to pressure switch.
- 2. Extend collector box pressure tube (green label) which was previously connected to condensate trap relief port connection by splicing to small diameter tube (factory-supplied in loose parts bag).
- 3. Connect collector box pressure tube (green label) to pressure switch connection labeled COLLECTOR BOX.
- 4. Extend collector box pressure tube (pink label) which was previously connected to pressure switch by splicing to remaining small diameter tube (factory-supplied in loose parts bag).
- 5. Route this extended tube (pink label) to condensate trap relief port connection.
- 6. Determine appropriate length, cut, and connect tube.
- 7. Clamp tube to relief port connection.

E. Condensate Trap Freeze Protection

Refer to Condensate Drain Protection section for recommendations and procedures.

IV. HORIZONTAL LEFT (SUPPLY-AIR DISCHARGE) APPLICATIONS

A horizontal left furnace application is where furnace blower is located to the right of combustion and controls section of furnace, and conditioned air is discharged to the left.

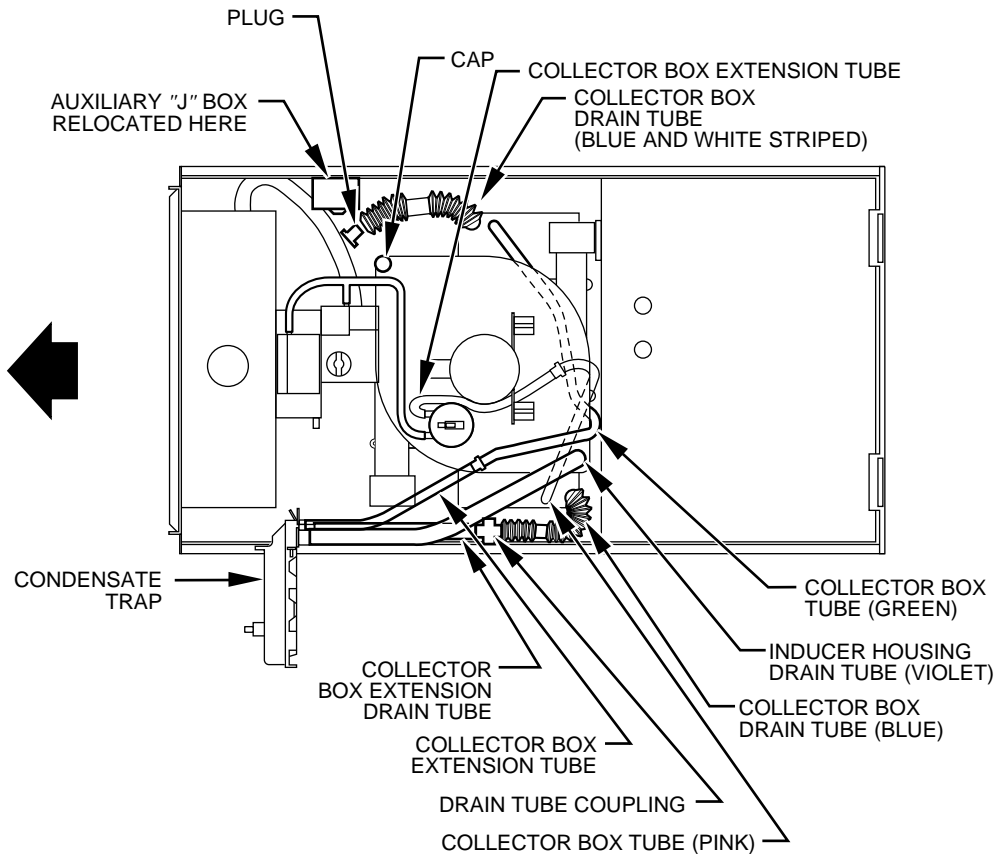
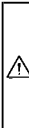

Fig. 9—Horizontal Left Tube Configuration

 **CAUTION:** Local codes may require a drain pan under entire furnace and condensate trap when a condensing furnace is used in an attic application or over a finished ceiling.

NOTE: In Canada, installations shall be in accordance with current NSCSGPIIC and/or local codes.

NOTE: The auxiliary junction box (J-Box) MUST be relocated to opposite side of furnace casing. (See Fig. 9.) See Electrical Connection section for J-Box relocation.

A. Condensate Trap Location

The condensate trap must be removed from the factory-installed blower shelf location and relocated in selected application location as shown in Fig. 2 or 9.

To relocate condensate trap from the blower shelf to desired location, perform the following:

1. Remove 3 tubes connected to condensate trap.
2. Remove trap from blower shelf by gently pushing tabs inward and rotating trap.
3. Remove casing hole filler cap from casing hole. (See Fig. 2 or 9.)
4. Install casing hole filler cap into blower shelf hole where trap was removed.
5. Install condensate trap into casing hole by inserting tube connection stubs through casing hole and rotating until tabs snap into locking position.

B. Condensate Trap Tubing

NOTE: See Fig. 9 or tube routing label on main furnace door to check for proper connections.

1. Collector Box Drain Tube
 - a. Install drain tube coupling (factory-supplied in loose parts bag) into collector box drain tube (blue label) which was previously connected to condensate trap.
 - b. Connect large diameter drain tube and clamp (factory-supplied in loose parts bag) to drain tube coupling, extending collector box drain tube.
 - c. Route extended tube (blue label) to condensate trap and cut to appropriate length.
 - d. Clamp tube to prevent any condensate leakage.
2. Inducer Housing Drain Tube
 - a. Remove and discard LOWER (molded) inducer housing drain tube which was previously connected to condensate trap.
 - b. Use inducer housing drain extension tube (violet label and factory-supplied in loose parts bag) to connect LOWER inducer housing drain connection to the condensate trap.
 - c. Determine appropriate length, cut, and connect tube.
 - d. Clamp tube to prevent any condensate leakage.
3. Relief Port Tube
 - a. Extend collector box tube (green label) which was previously connected to the condensate trap by splicing to small diameter tube (factory-supplied in loose parts bag).
 - b. Route extended collector box pressure tube to relief port connection on the condensate trap.
 - c. Determine appropriate length, cut, and connect tube.
 - d. Clamp tube to prevent any condensate leakage.

C. Condensate Trap Field Drain Attachment

Refer to Condensate Drain section for recommendations and procedures.

D. Pressure Switch Tubing

The LOWER collector box pressure tube (pink label) is factory connected to the pressure switch for use when furnace is installed in UPFLOW applications. This tube MUST be disconnected, extended, rerouted, and then reconnected to the pressure switch in HORIZONTAL LEFT applications.

NOTE: See Fig. 9 or tube routing label on main furnace door to check for proper connections.

Modify tube as described below.

1. Disconnect collector box pressure tube (pink label) attached to pressure switch.
2. Use smaller diameter tube (factory-supplied in loose parts bag) to extend tube disconnected in item 1.
3. Route extended tube:
 - a. Behind inducer housing.
 - b. Between blower shelf and inducer housing.
 - c. Behind inducer motor bracket.
 - d. Between inducer motor and pressure switch.
4. Determine appropriate length, cut, and reconnect tube to pressure switch connection labeled COLLECTOR BOX.

E. Condensate Trap Freeze Protection

Refer to Condensate Drain Protection section for recommendations and procedures.

F. Construct a Working Platform

Construct working platform where all required furnace clearances are met. (See Fig. 3 and 10.)

 **CAUTION:** The condensate trap MUST be installed below furnace. See Fig. 4 for dimensions. The drain connection to condensate trap must also be properly sloped to an open drain.

NOTE: Combustion-air and vent pipes are restricted to a minimum length of 5 ft. (See Table 6.)

NOTE: A 12-in. minimum offset pipe section is recommended with short (5 to 8 ft) vent systems. This recommendation is to reduce excessive condensate droplets from exiting the vent pipe. (See Fig. 10 or 28.)

V. HORIZONTAL RIGHT (SUPPLY-AIR DISCHARGE) APPLICATIONS

A horizontal right furnace application is where furnace blower is located to the left of combustion and controls section of furnace, and conditioned air is discharged to the right.

 **CAUTION:** Local codes may require a drain pan under entire furnace and condensate trap when a condensing furnace is used in attic application or over a finished ceiling.

NOTE: In Canada, installations shall be in accordance with current NSCSGPIIC Installation Codes and/or local codes.

A. Condensate Trap Location

The condensate trap must be removed from the factory-installed blower shelf location and relocated in selected application location as shown in Fig. 2 or 11.

To relocate condensate trap from the blower shelf to desired location, perform the following:

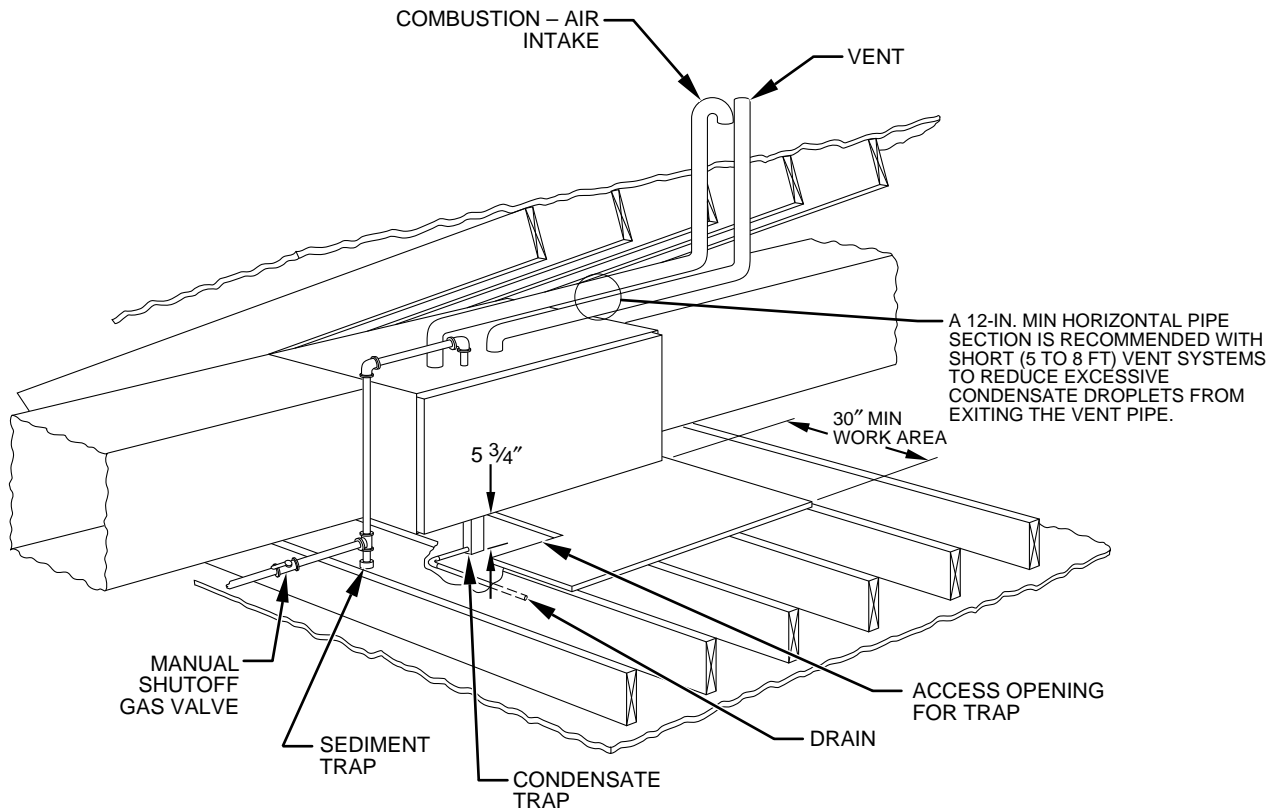

NOTE: LOCAL CODES MAY REQUIRE A DRAIN PAN UNDER THE FURNACE AND CONDENSATE TRAP WHEN A CONDENSING FURNACE IS INSTALLED ABOVE FINISHED CEILINGS.

A93031

Fig. 10—Attic Location and Working Platform

1. Remove 3 tubes connected to condensate trap.
2. Remove trap from blower shelf by gently pushing tabs inward and rotating trap.
3. Remove casing hole filler cap from casing hole. (See Fig. 2 or 11.)
4. Install casing hole filler cap into blower shelf hole where trap was removed.
5. Install condensate trap into casing hole by inserting tube connection stubs through casing hole and rotating until tabs snap into locking position.

B. Condensate Trap Tubing

NOTE: See Fig. 11 or tube routing label on main furnace door to check for proper connections.

1. Collector Box Drain Tube
 - a. Remove factory-installed plug from LOWER collector box drain tube (blue and white striped label).
 - b. Install removed clamp and plug into UPPER collector box drain tube (blue label) which was previously connected to condensate trap.
 - c. Connect LOWER collector box drain tube (blue and white striped label) to condensate trap. Tube does not need to be cut.
 - d. Clamp tube to prevent any condensate leakage.
2. Inducer Housing Drain Tube
 - a. Remove factory-installed cap and clamp from LOWER inducer housing drain connection.
 - b. Remove and discard UPPER (molded) inducer housing drain tube which was previously connected to condensate trap.

- c. Install cap and clamp on UPPER inducer housing drain connection where molded drain tube was removed.
- d. Use inducer housing drain extension tube (violet label and factory-supplied in loose parts bag) to connect LOWER inducer housing drain connection to condensate trap.
- e. Determine appropriate length, cut, and connect tube to condensate trap.
- f. Clamp tube to prevent any condensate leakage.

3. Relief Port Tube

Refer to Pressure Switch Tubing section for connection procedure.

C. Condensate Trap Field Drain Attachment

Refer to Condensate Drain section for recommendations and procedures.

D. Pressure Switch Tubing

One collector box pressure tube (pink label) is factory connected to the pressure switch for use when furnace is installed in UPFLOW applications. This tube **MUST** be disconnected and used for the condensate trap relief port tube. The other collector box pressure tube (green label) which was factory connected to the condensate trap relief port connection **MUST** be connected to the pressure switch in DOWNFLOW or HORIZONTAL RIGHT applications.

NOTE: See Fig. 11 or tube routing label on main furnace door to check for proper connections.

Relocate tubes as described below.

1. Disconnect collector box pressure tube (pink label) attached to pressure switch.

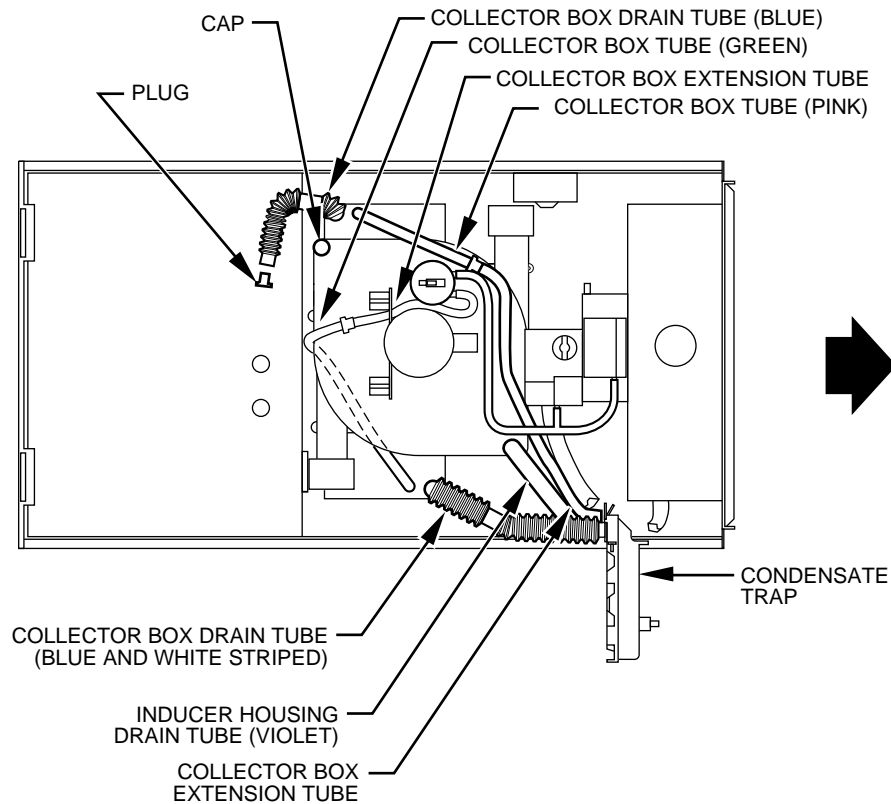

→ Fig. 11—Horizontal Right Tube Configuration

- 2. Extend collector box pressure tube (green label) which was previously connected to condensate trap relief port connection by splicing to small diameter tube (factory-supplied in loose parts bag).
- 3. Route extended collector box pressure tube behind inducer motor bracket then between inducer motor and pressure switch.
- 4. Connect collector box pressure tube (green label) to pressure switch connection labeled COLLECTOR BOX.
- 5. Use remaining smaller diameter tube (factory-supplied in loose parts bag) to extend collector box pressure tube (pink label) which was previously connected to pressure switch.
- 6. Route this extended tube (pink label) to condensate trap relief port connection.
- 7. Determine appropriate length, cut, and connect tube.
- 8. Clamp tube to relief port connection.

E. Condensate Trap Freeze Protection

Refer to Condensate Drain Protection section for recommendations and procedures.

F. Construct a Working Platform

Construct working platform where all required furnace clearances are met. (See Fig. 3 and 10.)

CAUTION: The condensate trap **MUST** be installed below furnace. See Fig. 4 for dimensions. The drain connection to condensate trap must also be properly sloped to an open drain.

NOTE: Combustion-air and vent pipes are restricted to a minimum length of 5 ft. (See Table 6.)

NOTE: A 12-in. minimum offset pipe section is recommended with short (5 to 8 ft) vent systems. This recommendation is to reduce excessive condensate droplets from exiting the vent pipe. (See Fig. 10 or 28.)

LOCATION

I. GENERAL

When a furnace is installed so that supply ducts carry air to areas outside the space containing the furnace, return air must also be handled by ducts sealed to furnace casing. The ducts terminate outside the space containing the furnace to ensure there will not be a negative pressure condition within equipment room or space. Furnace may be located in a confined space without special provisions for dilution or ventilation air. This furnace must be installed so electrical components are protected from water.

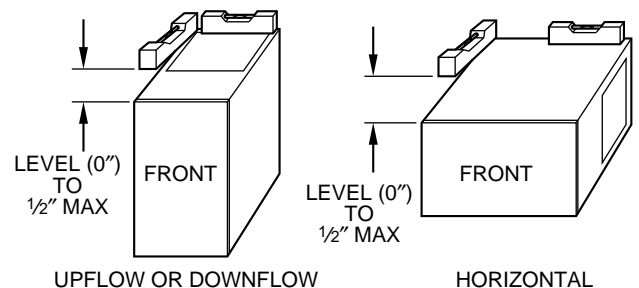

A93025

NOTE: For proper furnace operation, install furnace so that it is level or pitched forward within 1/2 in. to ensure proper condensate drainage from secondary heat exchangers.

Locate furnace as close to center of air distribution system as possible.

Locate furnace so combustion-air pipe maximum lengths are not exceeded. Refer to Table 6—Maximum Allowable Pipe Length.

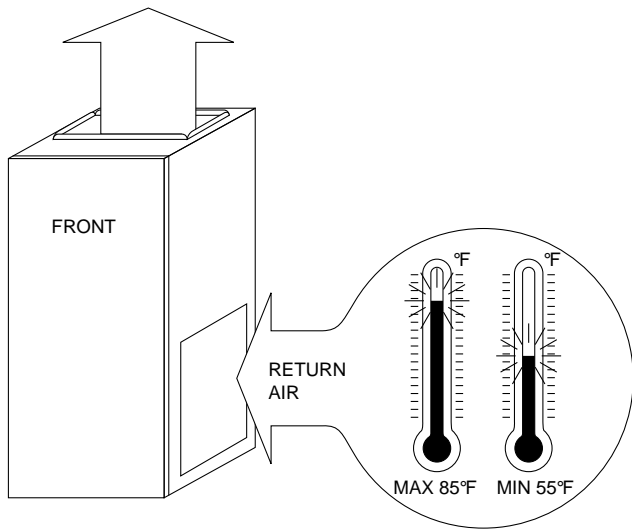

A93042

NOTE: These furnaces are designed for a minimum continuous return-air temperature of 60°F or intermittent operation down to 55°F such as when used with a night setback thermostat. Return-air temperature must not exceed a maximum of 85°F. Failure to follow these return-air temperature limits may affect reliability of heat exchangers, motors, and controls.

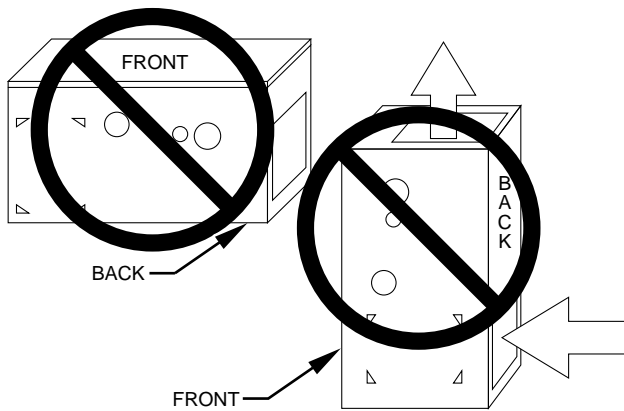

A93043

WARNING: Do not install furnace on its back. Safety control operation will be adversely affected. Never connect return-air ducts to back of furnace. Failure to follow this warning could result in fire, personal injury, or death.

CAUTION: If these furnaces are used during construction when adhesives, sealers, and/or new carpets are being installed, make sure all combustion and circulating air requirements are followed. If operation of furnace is required during construction, use clean outside air for combustion and ventilation. Compounds of chlorine and fluorine, when burned with combustion air, form acids which will cause corrosion of heat exchangers. Some of these compounds are found in paneling, dry wall adhesives, paints, thinners, masonry cleaning materials, and many other solvents commonly used in construction process. Excessive exposure to contaminated combustion air will result in safety and performance related problems.

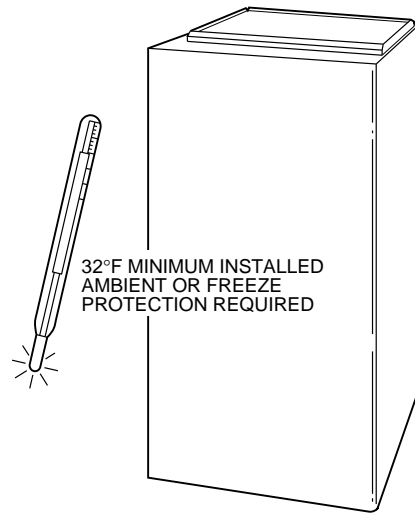

A93058

CAUTION: If these furnaces are installed in an unconditioned space where ambient temperatures may be 32°F or lower, freeze protection measures must be taken.

Provide ample space for servicing and cleaning. Always comply with minimum fire protection clearances shown on unit's clearance to combustibles label. (See Fig. 3.) Locate furnace where available electric power and gas supplies meet specifications on furnace rating plate.

II. FURNACE LOCATION RELATIVE TO COOLING EQUIPMENT

The cooling coil must be installed parallel with or on downstream side of furnace to avoid condensation in heat exchanger. When installed parallel with a furnace, dampers or other means used to control flow of air must prevent chilled air from entering furnace. If dampers are manually operated, they must be equipped with a means to prevent operation of either unit unless damper is in full-heat or full-cool position.

III. HAZARDOUS LOCATIONS

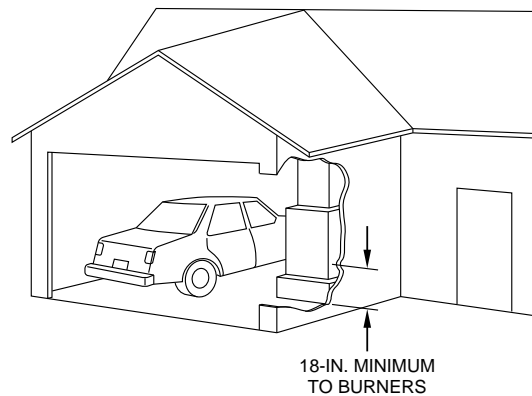

A93044

WARNING: When furnace is installed in a residential garage, it must be installed so that burners and ignition sources are located a minimum of 18 in. above floor. The furnace must be located or protected to avoid physical damage by vehicles. When furnace is installed in a public garage, airplane hangar, or other building having a hazardous atmosphere, unit must be installed in accordance with requirements of National Fire Protection Association, Inc.

INSTALLATION

I. LEVELING LEGS (IF DESIRED)

When furnace is used in upflow position with side inlet(s), leveling legs may be desired. (See Fig. 12.) Install field-supplied, corrosion-resistant 5/16-in. machine bolts and nuts.

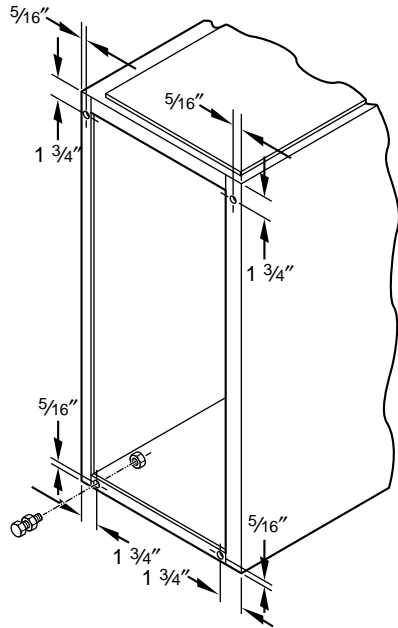

Fig. 12—Leveling Legs

A89014

NOTE: The maximum length of bolt should not exceed 1-1/2 in.

1. Position furnace on its back. Locate and drill a 5/16-in. diameter hole in each bottom corner of furnace. (See Fig. 12.) Holes in bottom closure panel may be used as guide locations.
2. For each hole, install nut on bolt and then install bolt and nut in hole. (Install flat washer if desired.)
3. Install another nut on other side of furnace base. (Install flat washer if desired.)
4. Adjust outside nut to provide desired height, and tighten inside nut to secure arrangement.

NOTE: Bottom closure must be used when leveling legs are used. See Bottom Closure Panel section.

→ II. INSTALLATION IN UPFLOW OR DOWNFLOW APPLICATIONS

NOTE: For downflow applications, this furnace is approved for use on combustible flooring when special base (available from manufacturer) Part No. KGASB0201ALL is used. Special base is not required when this furnace is installed on manufacturer's Coil Assembly Part No. CD5 or CK5, or Coil Box Part No. KCAKC is used.

1. Determine application being installed from Table 1.
2. Construct hole in floor per dimensions specified in Table 1 and Fig. 13.
3. Construct plenum to dimensions specified in Table 1 and Fig. 13.
4. If downflow subbase (KGASB) is used, install as shown in Fig. 14.

If coil assembly CD5 or CK5 or Coil Box KCAKC is used, install as shown in Fig. 15.

NOTE: Remove furnace perforated, discharge duct flanges when they interfere with mating flanges on coil on downflow subbase. To remove furnace perforated, discharge duct flange, use wide duct pliers or duct flange tool to bend flange back and forth until it breaks off. Be careful of sharp edges. (See Fig. 16.)



WARNING: Do not bend duct flanges inward as shown in Fig. 16. This will affect airflow across heat exchangers and may cause limit cycling or premature heat exchanger failure. Remove duct flange completely or bend it inward a minimum of 210° as shown in Fig. 16.

NOTE: For 140 size unit when installed in downflow orientation, cut the white jumper wire off between terminals PL1-6 and PL1-9. Refer to Fig. 24 for location of jumper. Cut jumper close to connector and remove wire to avoid a short circuit.

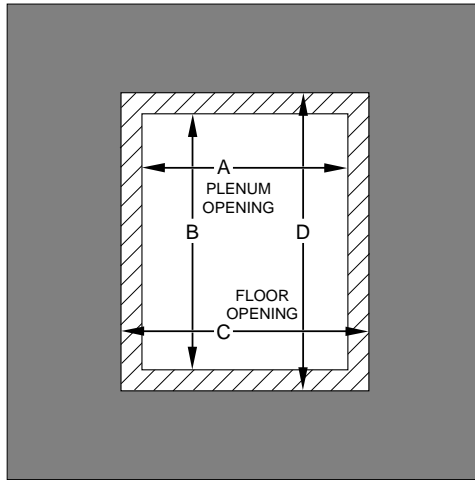

A96283

Fig. 13—Floor and Plenum Opening Dimensions

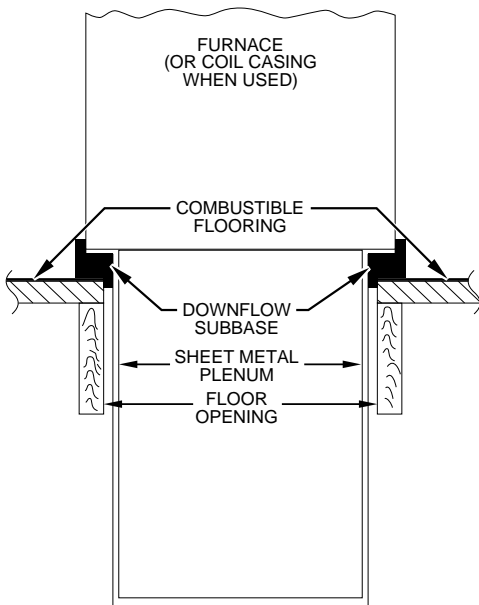

A96285

Fig. 14—Furnace, Plenum, and Subbase Installed on a Combustible Floor

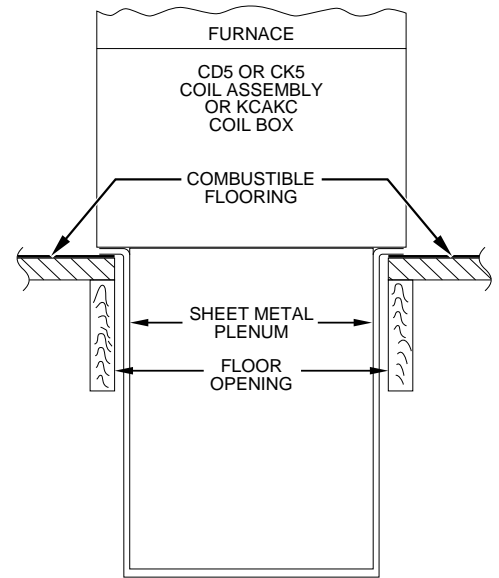

A96284

Fig. 15—Furnace, Plenum, and Coil Assembly or Coil Box Installed on a Combustible Floor

TABLE 1—OPENING DIMENSIONS (IN.)

FURNACE CASING WIDTH	APPLICATION	PLENUM OPENING		FLOOR OPENING	
		A	B	C	D
17-1/2	Upflow Applications	16	24-1/8	16-5/8	24-3/4
	Downflow Applications on Non-Combustible Flooring	15-7/8	19	16-1/2	19-5/8
	Downflow Applications on Combustible Flooring Using KGASB Subbase Furnace with or without CD5 or CK5 Coil Assembly or KCAKC Coil Box	15-1/8	19	16-3/4	20-3/8
	Downflow Applications on Combustible Flooring NOT Using KGASB Subbase Furnace with CD5 or CK5 Coil Assembly or KCAKC Coil Box	15-1/2	19	16-1/2	20
21	Upflow Applications	19-1/2	24-1/8	20-1/8	24-3/4
	Downflow Applications on Non-Combustible Flooring	19-3/8	19	20	19-5/8
	Downflow Applications on Combustible Flooring Using KGASB Subbase Furnace with or without CD5 or CK5 Coil Assembly or KCAKC Coil Box	18-5/8	19	20-1/4	20-3/8
	Downflow Applications on Combustible Flooring NOT Using KGASB Subbase Furnace with CD5 or CK5 Coil Assembly or KCAKC Coil Box	19	19	20	20
24-1/2	Upflow Applications	23	24-1/8	23-5/8	24-3/4
	Downflow Applications on Non-Combustible Flooring	22-7/8	19	23-1/2	19-5/8
	Downflow Applications on Combustible Flooring Using KGASB Subbase Furnace with or without CD5 or CK5 Coil Assembly or KCAKC Coil Box	22-1/8	19	23-3/4	20-3/8
	Downflow Applications on Combustible Flooring NOT Using KGASB Subbase Furnace with CD5 or CK5 Coil Assembly or KCAKC Coil Box	22-1/2	19	23-1/2	20

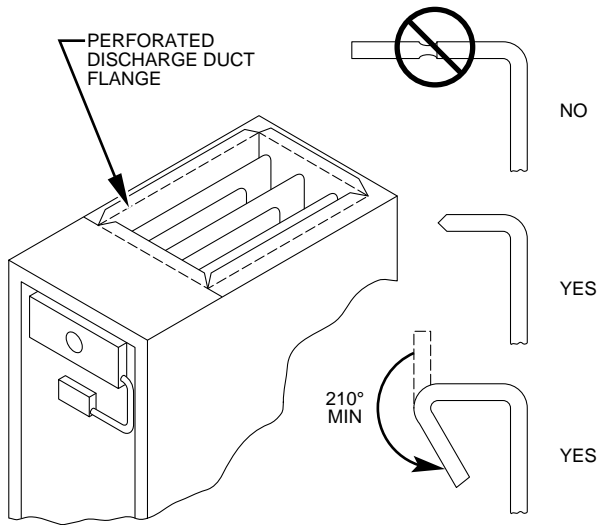

Fig. 16—Duct Flanges

A93029

III. INSTALLATION IN HORIZONTAL APPLICATIONS

→ These furnaces can be installed horizontally in either horizontal left or right discharge position. In a crawlspace, furnace can either be hung from floor joist or installed on suitable blocks or pad. Furnace can be suspended from each corner by hanger bolts and angle iron supports. (See Fig. 17.) Cut hanger bolts (4 each 3/8-in. all-thread rod) to desired length. Use 1 X 3/8-in. flat washers, 3/8-in. lockwashers, and 3/8-in. nuts on hanger rods as shown in Fig. 17. Dimples are provided for hole locations. (See Fig. 2.)

→ **CAUTION:** The entire length of furnace **MUST** be supported when furnace is used in a horizontal position to ensure proper draining. When suspended, bottom brace supports sides and center blower shelf. When unit is supported from the ground, blocks or pad should support sides and center blower shelf area.

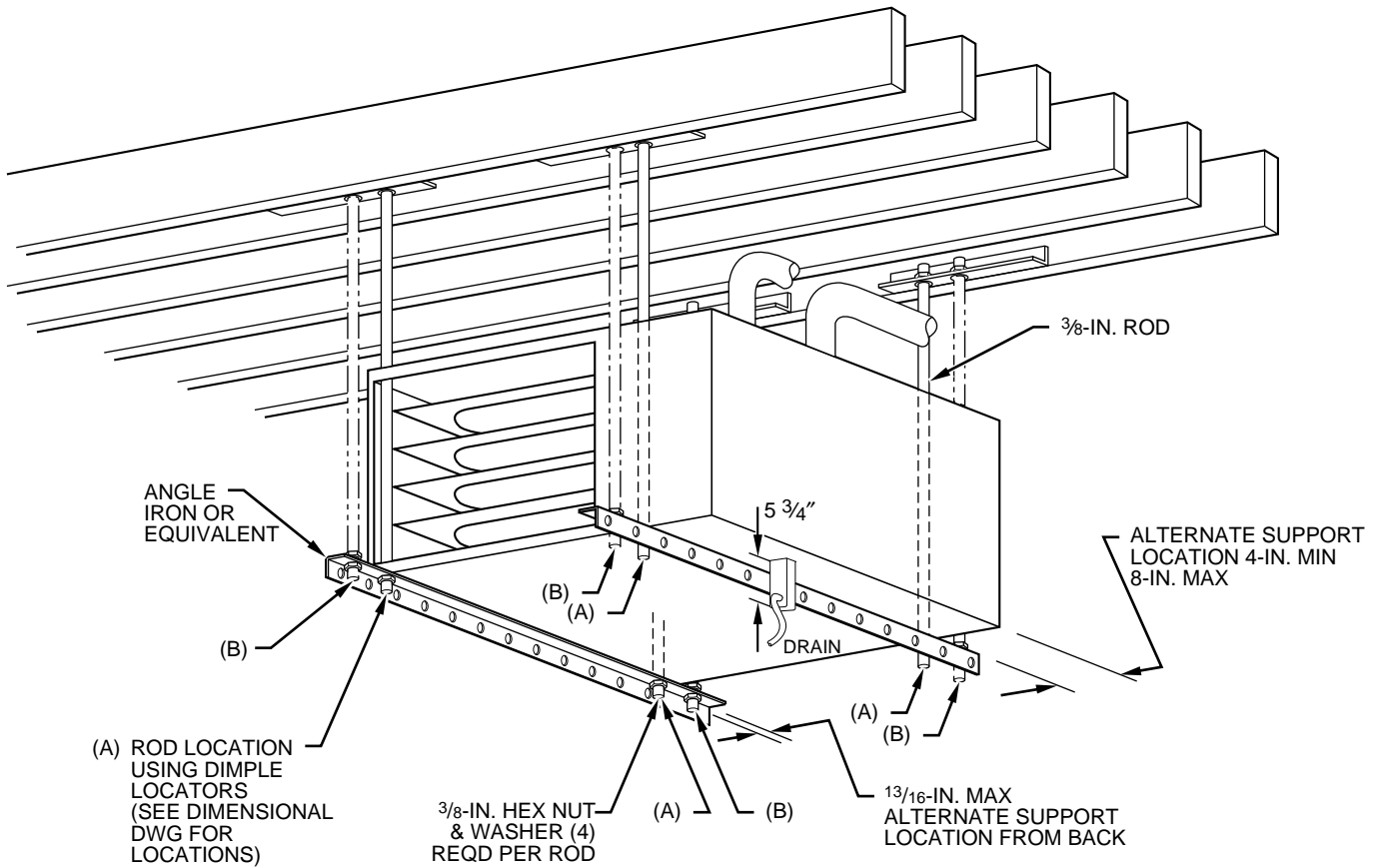

(A) ROD LOCATION USING DIMPLE LOCATORS (SEE DIMENSIONAL DWG FOR LOCATIONS)

3/8-IN. HEX NUT & WASHER (4) REQD PER ROD

13/16-IN. MAX ALTERNATE SUPPORT LOCATION FROM BACK

ALTERNATE SUPPORT LOCATION 4-IN. MIN 8-IN. MAX

- (A) PREFERRED ROD LOCATION
- (B) ALTERNATE ROD LOCATION

NOTES: 1. A 1 in. clearance minimum between top of furnace and combustible material.

2. The entire length of furnace must be supported when furnace is used in horizontal position to ensure proper drainage.

Fig. 17—Crawlspace Horizontal Application

A93304

IV. FILTER ARRANGEMENT

CAUTION: Never operate unit without a filter or with blower access panel removed.

Factory-supplied washable framed filters are shipped in blower compartment. Determine location for filter and relocate filter retaining wire if necessary. See Table 2 to determine correct filter size for desired filter location. Table 2 indicates filter size, location, and quantity shipped with this furnace. See Fig. 2 for location and size of bottom and side return-air openings.

TABLE 2—FILTER INFORMATION

FURNACE CASING WIDTH (IN.)	FILTER SIZE (IN.)*		FILTER TYPE FRAMED
	Side Return	Bottom Return	
17-1/2	(1) 16 X 25 X 1†	(1) 16 X 25 X 1	Cleanable
21	(1) 16 X 25 X 1	(1) 20 X 25 X 1†	Cleanable
24-1/2	(2) 16 X 25 X 1†	(1) 24 X 25 X 1	Cleanable

* Filters can be field modified by cutting frame as marked and folding to desired size. Alternate sizes can be ordered from your distributor or dealer.
 † Factory-provided with furnace.

CAUTION: Air delivery above 1800 CFM requires that both sides, a combination of 1 side and bottom, or bottom only of furnace be used for return air.

NOTE: Side return-air openings can ONLY be used in UPFLOW configurations. Install filter(s) as shown in Fig. 18.

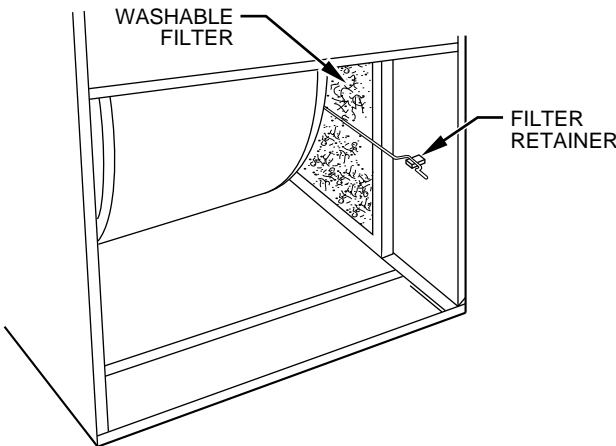

Fig. 18—Filter Installed for Side Inlet

A93045

Bottom return-air opening may be used with all 4 orientations. Filter may need to be cut to fit some furnace widths. Install filter as shown in Fig. 19.

NOTE: Remove and discard bottom closure panel when bottom inlet is used.

V. BOTTOM CLOSURE PANEL

These furnaces are shipped with bottom enclosure panel installed in bottom return-air opening. This panel MUST be in place when side return air is used.

To remove bottom closure panel, perform following:

1. Tilt or raise furnace and remove 2 screws holding front filler panel. (See Fig. 20.)
2. Rotate front filler panel downward to release holding tabs.
3. Remove bottom closure panel.
4. Reinstall front filler panel and screws.

17½-IN. WIDE CASINGS ONLY:
 INSTALL FIELD-SUPPLIED FILTER FILLER STRIP UNDER FILTER.

24½-IN. WIDE CASINGS ONLY:
 CUT AND FOLD FACTORY-PROVIDED FILTERS AS SHOWN TO DESIRED SIZE.

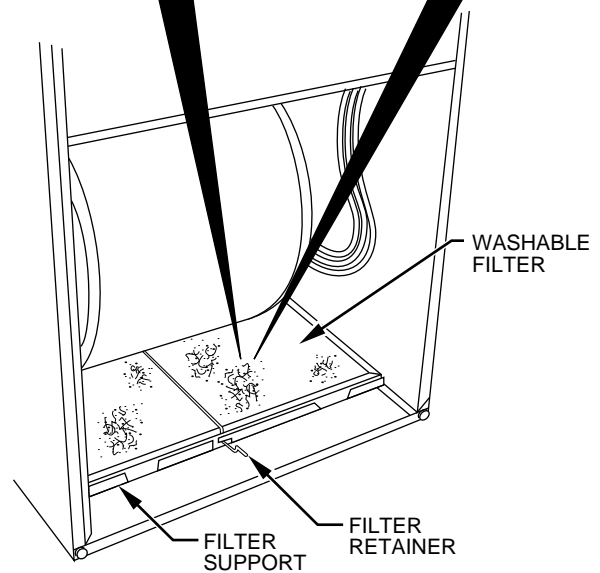
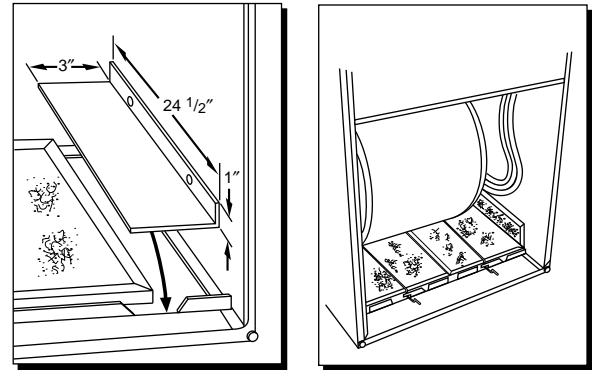

Fig. 19—Bottom Filter Arrangement

A96030

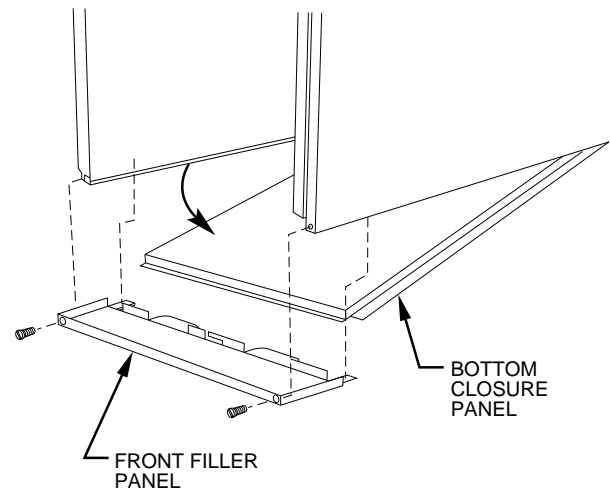

Fig. 20—Removing Bottom Closure Panel

A93047

VI. GAS PIPING

Gas piping must be installed in accordance with national and local codes. Refer to current edition of NFGC. Canadian installations must be made in accordance with NSCNGPIC and all authorities having jurisdiction. Gas supply line should be a separate line running directly from meter to furnace, if possible. Refer to Table 3 for recommended gas pipe sizing. Risers must be used to connect to furnace and to meter. Support all gas piping with appropriate straps, hangers, etc. Use a minimum of 1 hanger every 6 ft. Joint compound (pipe dope) should be applied sparingly and only to male threads of joints. Pipe dope must be resistant to propane gas.

CAUTION: Connect gas pipe to furnace using a backup wrench to avoid damaging gas controls.

WARNING: Gas valve shutoff switch **MUST** be facing forward or tilted upward. Failure to follow this warning could result in property damage or death.

WARNING: Never purge a gas line into a combustion chamber. Never use matches, candles, flame, or other sources of ignition for purpose of checking leakage. Use a soap-and-water solution to check for leakage. A failure to follow this warning could result in fire, explosion, personal injury, or death.

WARNING: Use proper length of pipe to avoid stress on gas control manifold. Failure to follow this warning could result in a gas leak resulting in fire, explosion, personal injury, or death.

TABLE 3—MAXIMUM CAPACITY OF PIPE*

NOMINAL IRON PIPE SIZE (IN.)	INTERNAL DIAMETER (IN.)	LENGTH OF PIPE (FT)				
		10	20	30	40	50
1/2	0.622	175	120	97	82	73
3/4	0.824	360	250	200	170	151
1	1.049	680	465	375	320	285
1-1/4	1.380	1400	950	770	660	580
1-1/2	1.610	2100	1460	1180	990	900

→ * Cubic ft of gas per hr for gas pressures of 0.5 psig (14-in. wc) or less, and a pressure drop of 0.5-in. wc (based on a 0.60 specific gravity gas). Ref: Table 10-2 NFPA 54-1996.

Install a sediment trap in riser leading to furnace. Trap can be installed by connecting a tee to riser leading to furnace so straight-through section of tee is vertical. Then connect a capped nipple into lower end of tee. Capped nipple should extend below level of gas controls. Place a ground joint union between gas control manifold and manual gas shutoff valve. (See Fig. 21.)

CAUTION: If a flexible connector is required or allowed by authority having jurisdiction, black iron pipe shall be installed at gas valve and extend a minimum of 2 in. outside furnace casing.

An accessible manual shutoff valve **MUST** be installed upstream of furnace gas controls and within 6 ft of furnace. A 1/8-in. NPT

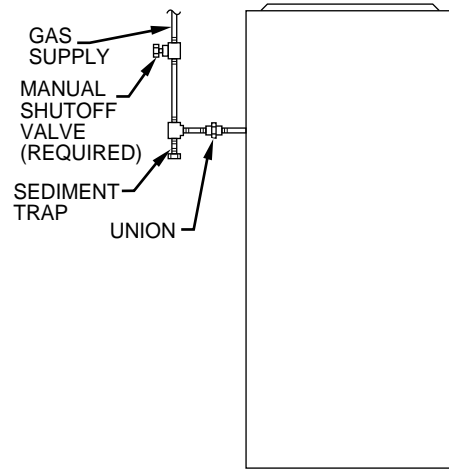

A93324

Fig. 21—Typical Gas Pipe Arrangement

plugged tapping, accessible for test gage connection, **MUST** be installed immediately upstream of gas supply connection to furnace and downstream of manual shutoff valve.

NOTE: The gas valve inlet press tap connection is suitable to use as test gage connection providing test pressure **DOES NOT** exceed maximum 0.5 psig (14-in. wc) stated on gas valve. (See Fig. 44.) Piping should be pressure tested in accordance with local and national plumbing and gas codes before furnace is attached. In Canada, refer to current edition of NSCNGPIC. If pressure exceeds 0.5 psig (14-in. wc), gas supply pipe must be disconnected from furnace and capped before pressure test. If test pressure is equal to or less than 0.5 psig (14-in. wc), turn off electric shutoff switch located on gas valve before test. It is recommended that ground joint union be loosened before pressure testing. After all connections have been made, purge lines and check for leakage.

ELECTRICAL CONNECTIONS

See Fig. 22 for field wiring diagram showing typical field 115-v and 24-v wiring. Check all factory and field electrical connections for tightness.

WARNING: Blower access panel door switch opens 115-v power to control center. No component operation can occur. Do not bypass or close switch with panel removed. Failure to follow this warning could result in personal injury or death.

CAUTION: Furnace control must be grounded for proper operation or control will lock out. Control is grounded through green wire routed to gas valve and burner box screw.

I. 115-V WIRING

Before proceeding with electrical connections, make certain that voltage, frequency, and phase correspond to that specified on unit rating plate. Also, check to be sure that service provided by utility is sufficient to handle load imposed by this equipment. Refer to rating plate or Table 4 for equipment electrical specifications.

Make all electrical connections in accordance with National Electrical Code (NEC) ANSI/NFPA 70-1996 and any local codes or ordinances that might apply. For Canadian installations, all electrical connections must be made in accordance with Canadian Electrical Code CSA C22.1 or subauthorities having jurisdiction. Use a separate, fused branch electrical circuit containing a properly sized fuse or circuit breaker for this furnace. See Table 4 for wire size and fuse specifications. A disconnecting means must be located within sight from and readily accessible to furnace.

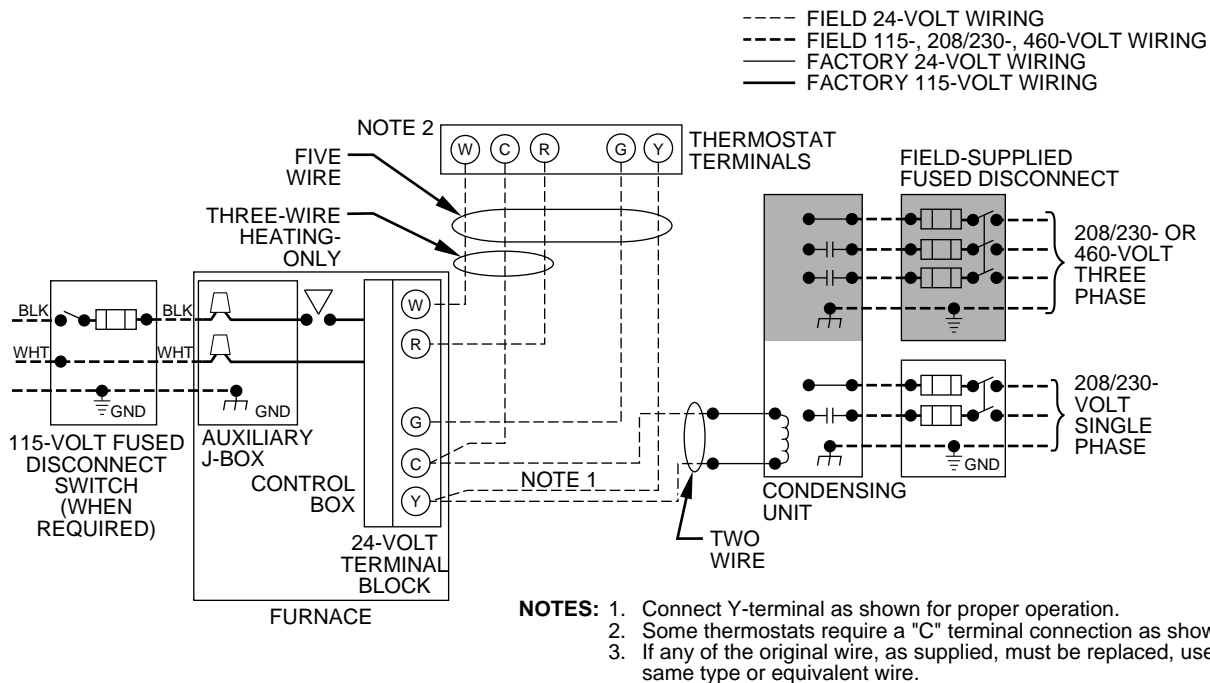

→ Fig. 22—Heating and Cooling Application Wiring Diagram

A96415

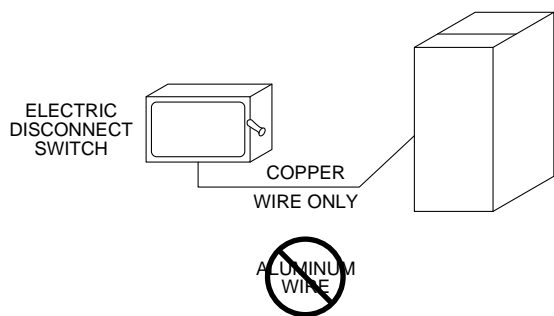

A93033

CAUTION: Do not connect aluminum wire between disconnect switch and furnace. Use only copper wire.

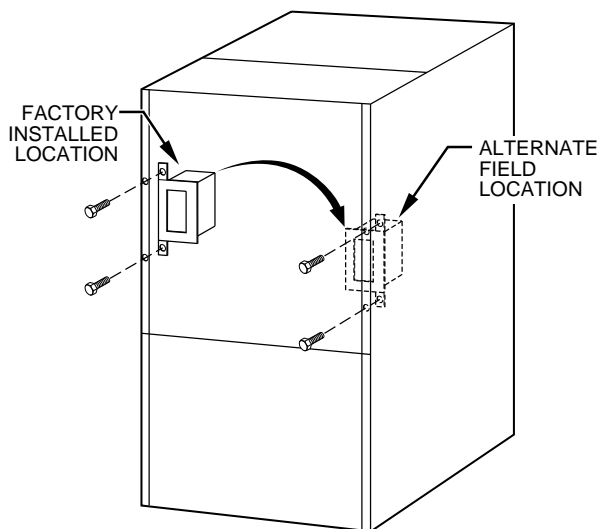

Fig. 23—Relocating J-Box

A93051

NOTE: Proper polarity must be maintained for 115-v wiring. If polarity is incorrect, control center LED status indicator light will flash rapidly and furnace will NOT operate.

WARNING: The cabinet MUST have an uninterrupted or unbroken ground according to NEC ANSI/NFPA 70-1996 and Canadian Electrical Code CSA C22.1 or local codes to minimize personal injury if an electrical fault should occur. This may consist of electrical wire or conduit approved for electrical ground when installed in accordance with existing electrical codes. Do not use gas piping as an electrical ground. Failure to follow this warning could result in electrical shock, fire, or death.

J-BOX RELOCATION

1. Remove 2 screws holding auxiliary J-box. (See Fig. 23.)
2. Rotate J-box 180° and attach box to right side, using holes provided.

CAUTION: If manual disconnect switch is to be mounted on furnace, select a location where a drill or fastener will not contact electrical or gas components.

II. 24-V WIRING

Make field 24-v thermostat connections at 24-v terminal block on control center. For proper cooling operation, Y wire from thermostat MUST be connected to Y terminal on control center, as shown in Fig. 22. The 24-v terminal board is marked for easy connection of field wiring. (See Fig. 24.) The 24-v circuit contains a 3-amp, automotive-type fuse located on control center. (See Fig. 25.) Any electrical shorts of 24-v wiring during installation, service, or maintenance may cause fuse to blow. If fuse replacement is required, use only a fuse of identical size (3 amp).

NOTE: Use AWG No. 18 color-coded copper thermostat wire for lengths up to 100 ft. For wire lengths over 100 ft, use AWG No. 16 wire.

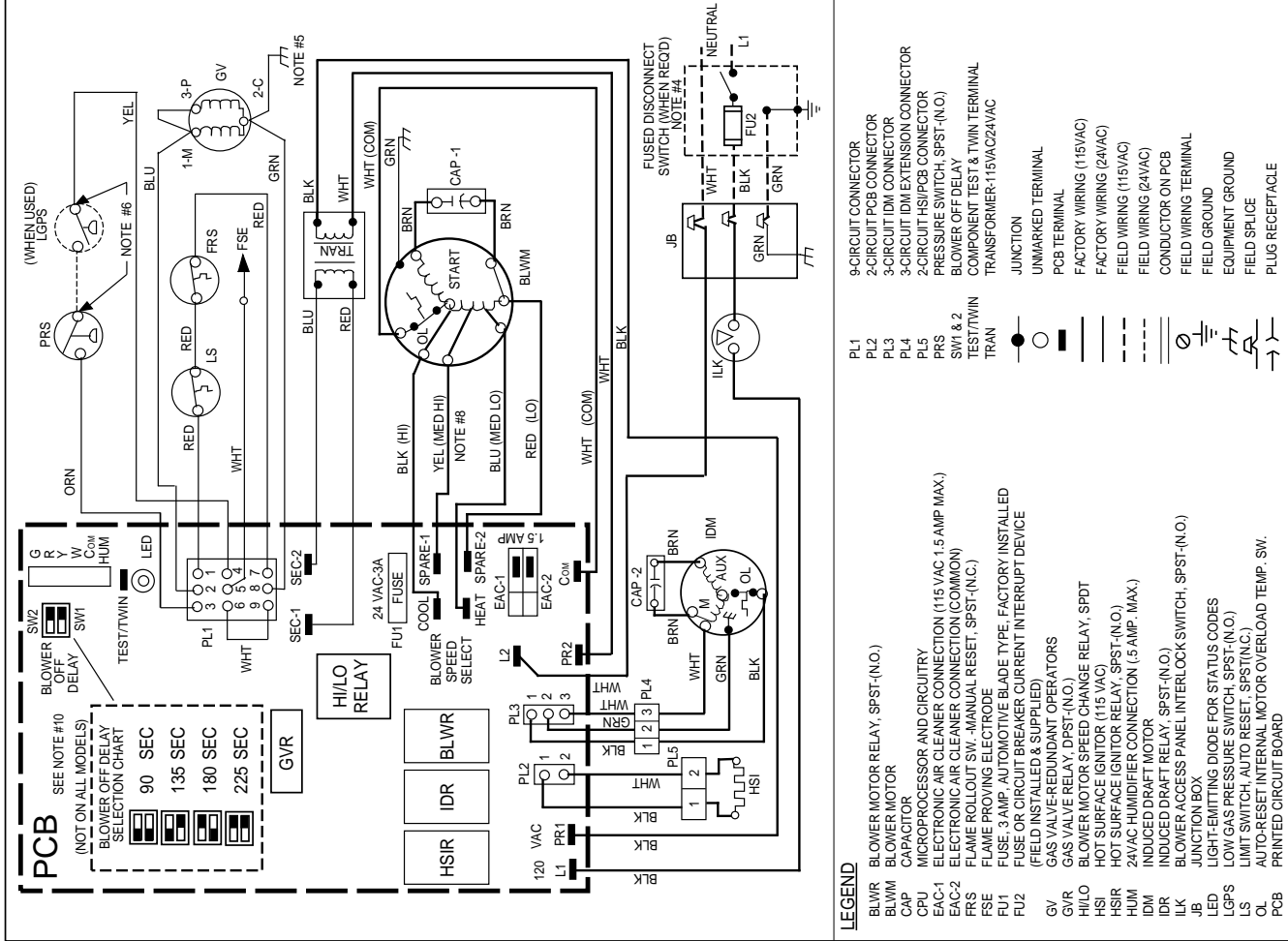
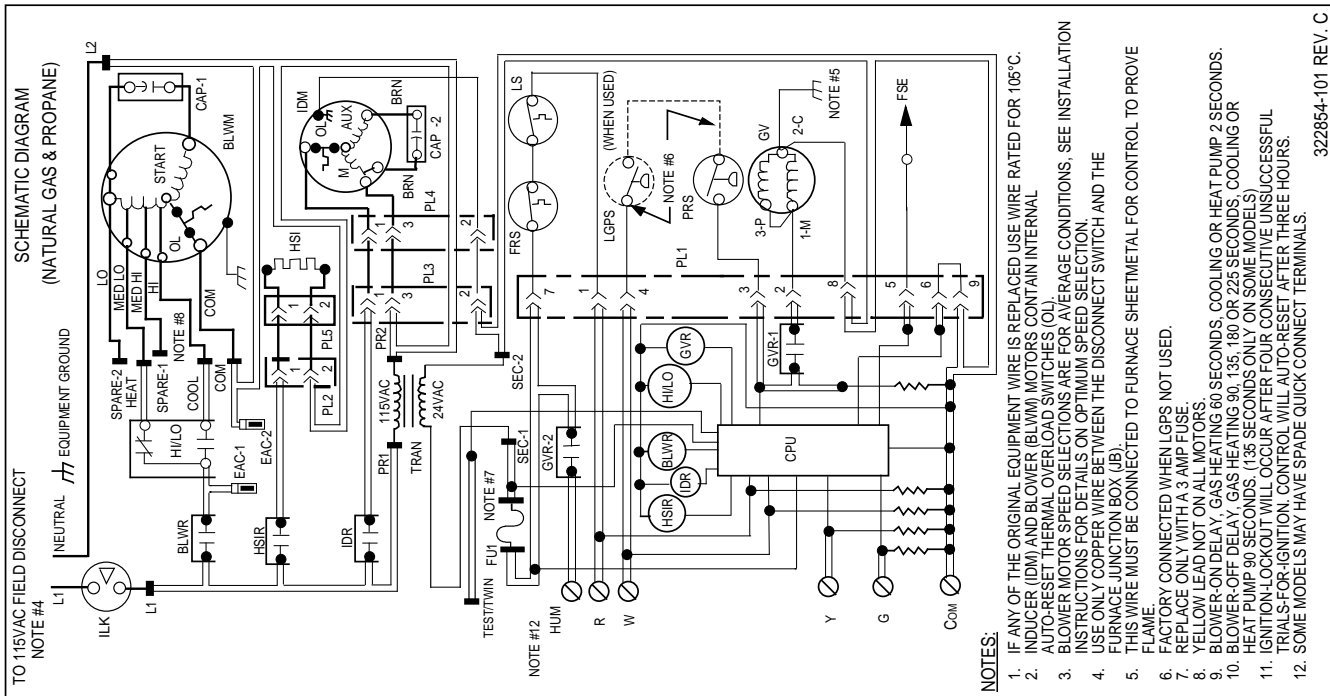

TABLE 4—ELECTRICAL DATA

UNIT SIZE	VOLTS—HERTZ—PHASE	OPERATING VOLTAGE RANGE		MAX UNIT AMPS	UNIT AMPACITY†	MIN WIRE GAGE	MAX WIRE LENGTH (FT)‡	MAX FUSE OR CKT BKR AMPS**
		Max*	Min*					
024040	115—60—1	127	104	6.1	8.4	14	44	15
036040	115—60—1	127	104	7.3	10.0	14	37	15
024060	115—60—1	127	104	6.1	8.4	14	44	15
036060	115—60—1	127	104	7.1	9.8	14	38	15
048060	115—60—1	127	104	9.5	12.8	14	29	15
036080	115—60—1	127	104	7.6	10.4	14	36	15
048080	115—60—1	127	104	10.0	13.4	14	28	15
060080	115—60—1	127	104	14.1	18.4	12	31	20
048100	115—60—1	127	104	10.2	13.5	14	27	15
060100	115—60—1	127	104	14.8	19.3	12	30	20
060120	115—60—1	127	104	14.6	19.1	12	30	20
→060140	115—60—1	127	104	14.3	18.8	12	30	20

* Permissible limits of voltage range at which unit will operate satisfactorily.

† Unit ampacity = 125 percent of largest operating component's full load amps plus 100 percent of all other potential operating components' (EAC, humidifier, etc.) full load amps.

‡ Length shown is as measured 1 way along wire path between unit and service panel for maximum 2 percent voltage drop.

** Time-delay fuse is recommended.

III. ACCESSORIES

1. Electronic Air Cleaner (EAC)

Two quick-connect terminals marked EAC-1 and EAC-2 are provided for EAC connection. (See Fig. 25.) These terminals are energized with 115v (1.5-amp maximum) during blower motor operation.

2. Humidifier (HUM)

A quick-connect terminal (HUM) and screw terminal (Com) are provided for 24-v humidifier connection. (See Fig. 24.) HUM terminal is energized with 24v (0.5-amp maximum) after inducer motor prepurge period.

NOTE: A field-supplied, 115-v controlled relay connected to EAC terminals may be added if humidifier operation is desired during blower operation.

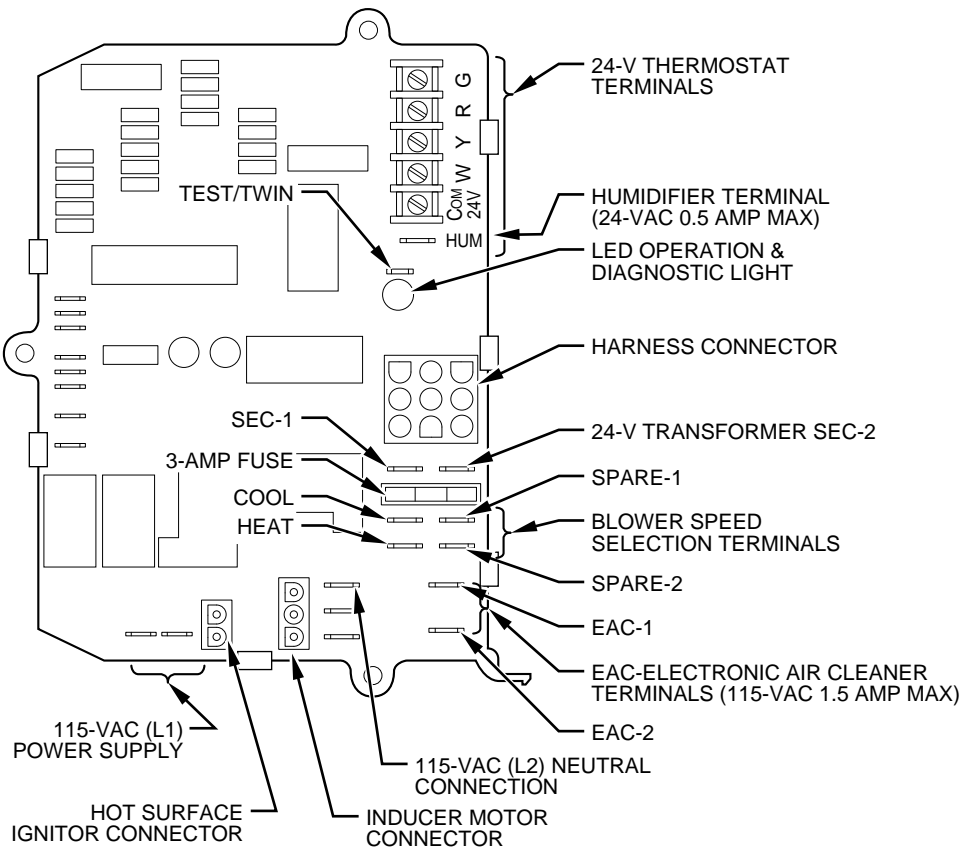

Fig. 25—Control Center

DIRECT VENTING

The 340MAV Furnaces require a dedicated (one 340MAV furnace only) direct-vent system. In a direct-vent system, all air for combustion is taken directly from outside atmosphere, and all flue products are discharged to outside atmosphere.

I. REMOVAL OF EXISTING FURNACES FROM COMMON VENT SYSTEMS

If furnace being replaced was connected to a common vent system with other appliances, the following steps shall be followed with each appliance connected to the venting system placed in operation, while any other appliances connected to the venting system are not in operation:

1. Seal any unused openings in the venting system.
2. Inspect the venting system for proper size and horizontal pitch as required in the National Fuel Gas Code, ANSI Z223.1 or the CAN/CGA B149 Installation Codes and these instructions. Determine that there is no blockage or restriction, leakage, corrosion, and other deficiencies which could cause an unsafe condition.
3. In so far as is practical, close all building doors and windows and all doors between the space in which the appliance(s) connected to the venting system are located and other spaces of the building. Turn on clothes dryers and any appliance not connected to the venting system. Turn on any exhaust fans, such as range hoods and bathroom exhausts, so they shall operate at maximum speed. Do not operate a summer exhaust fan. Close fireplace dampers.
4. Follow the lighting instructions. Place the appliance being inspected in operation. Adjust thermostat so appliance shall operate continuously.
5. Test for draft hood equipped appliance spillage at the draft hood relief opening after 5 minutes of main burner operation. Use the flame of a match or candle.
6. After it has been determined that each appliance connected to the venting system properly vents when tested as outlined above, return doors, windows, exhaust fans, fireplace dampers, and any other gas-burning appliance to their previous conditions of use.
7. If improper venting is observed during any of above tests, the venting system must be corrected.

Vent system or vent connectors may need to be resized. For any other appliances when resizing vent systems or vent connectors, system or connector must be sized to approach minimum size as determined using appropriate table found in the NFGC or NSC-NGPIC.

II. COMBUSTION-AIR AND VENT PIPING

A. General

Combustion-air and vent pipe fittings must conform to American National Standards Institute (ANSI) standards and American Society for Testing and Materials (ASTM) standards D1785 (schedule-40 PVC), D2665 (PVC-DWV), D2241 (SDR-21 and SDR-26 PVC), D2661 (ABS-DWV), F628 (schedule-40 ABS), or F891 (PVC-DWV cellular core). Pipe cement and primer must conform to ASTM standards D2564 (PVC) or D2235 (ABS). See Table 6 for maximum pipe lengths and Fig. 30, 31, 32, 33, and 34 for exterior piping arrangements.

In Canada construct all combustion-air and vent pipes for this unit of CSA or ULC certified schedule-40 PVC, PVC-DWV or ABS-DWV pipe and pipe cement. SDR pipe is NOT approved in Canada.

NOTE: Furnace combustion-air and vent pipe connections are sized for 2-in. pipe. Any pipe size change should be made outside furnace casing in vertical pipe. (See Fig. 26.) This allows proper drainage of vent condensate.

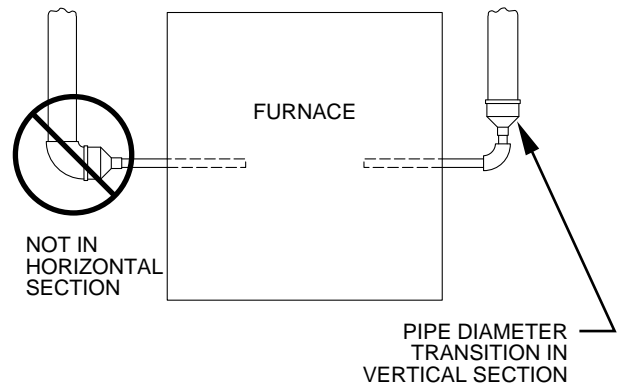

A93034

Fig. 26—Combustion-Air and Vent Pipe Diameter Transition Location and Elbow Configuration

Combustion-air and vent pipes must terminate together in same atmosphere pressure zone, either through roof or sidewall (roof termination preferred), using accessory termination kit. See Table 5 for required clearances.

TABLE 5—COMBUSTION-AIR AND VENT PIPE TERMINATION CLEARANCES

LOCATION	CLEARANCE (FT)	
	U.S.A.	Canada
Above grade level or above anticipated snow depth	1	1†
Dryer vent	3	3
From plumbing vent stack	3	3
From any mechanical fresh air intake	1	6
For furnaces with an input capacity less than 100,000 Btuh—from any non-mechanical air supply (windows or doors which can be opened) or combustion-air opening	1	1
For furnaces with an input capacity greater than 100,000 Btuh—from any non-mechanical air supply (windows or doors which can be opened) or combustion-air opening	1	3
From service regulator vent, electric and gas meters, and relief equipment	4*	6‡
Above grade when adjacent to public walkway	7	7

* Horizontal distance.

† 18 in. above roof surface in Canada.

‡ 36 in. to electric meter in Canada only.

NOTES:

1. If installing 2 adjacent 340MAV Furnaces, refer to Multiventing and Vent Terminations section for proper vent configurations.
2. When locating combustion-air and vent terminations, consideration must be given to prevailing winds, location, and other conditions which may cause recirculation of the appliance's own flue products or the flue products of adjacent vents. Recirculation can cause poor combustion, inlet condensate problems, and accelerated corrosion of heat exchangers.

Furnace combustion-air and vent pipe connections must be attached as shown in Fig. 27. Combustion-air intake plug fitting and inducer housing alternate vent cap may need to be relocated in some applications.

NOTE: Slope combustion-air and vent pipes a minimum of 1/4 in. per linear ft with no sags between hangers.

NOTE: Select 1 vent pipe connection and 1 combustion-air pipe connection.

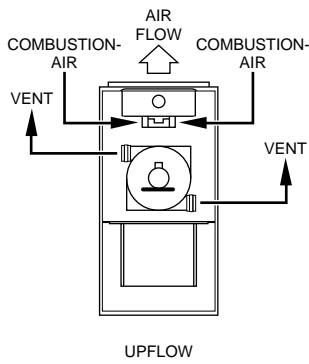

NOTE: Select 1 vent pipe connection and 1 combustion-air pipe connection.

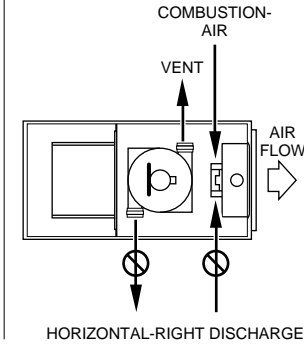
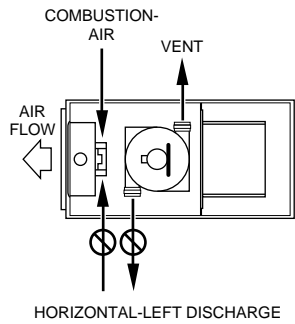
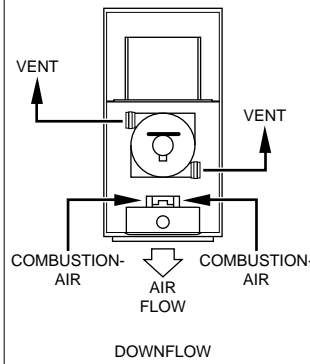

A96187

Fig. 27—Combustion-Air and Vent Pipe Connections

CAUTION: When combustion-air pipe is installed above a suspended ceiling, pipe must be insulated with 3/8-in. thick Armaflex-type insulation. Combustion-air pipe should also be insulated when it passes through warm, humid space.

CAUTION: When vent pipe is exposed to temperatures below freezing, such as when it passes through an unheated space or when a chimney is used as a raceway, pipe must be insulated as shown in Table 7 with Armaflex-type insulation.

CAUTION: Combustion air must not be taken from inside structure because inside air is frequently contaminated by halogens, which include fluorides, chlorides, bromides, and iodides. These elements are found in aerosols, detergents, bleaches, cleaning solvents, salts, air fresheners, adhesives, paint, and other household products. Locate combustion-air inlet as far as possible from swimming pool and swimming pool pump house. Excessive exposure to contaminated combustion air will result in safety and performance related problems.

WARNING: Solvent cements are combustible. Keep away from heat, sparks, and open flame. Use only in well-ventilated areas. Avoid breathing in vapor or allowing contact with skin or eyes. Failure to follow this warning could result in fire, property damage, personal injury, or death.

WARNING: All combustion-air and vent pipes must be airtight and watertight. Pipes must also terminate exactly as shown in Fig. 30, 31, 32, 33, or 34. Failure to follow this warning could result in property damage, personal injury, or death.

NOTE: The minimum combustion-air and vent pipe length (each) for these furnaces is 5 ft. Short pipe lengths (5-8 ft) may discharge water droplets. These droplets may be undesirable, and a 12-in. minimum offset pipe section is recommended, as shown in Fig. 28, to reduce excessive droplets from exiting vent pipe outlet.

B. Combustion-Air and Vent Pipe Diameter

Determine combustion-air and vent pipe diameter.

1. Using Table 6, individually determine the combustion-air and vent pipe diameters. Pick the larger of these 2 pipe diameters and use this diameter for both combustion-air and vent pipes.
2. When installing vent systems of short pipe length, use the smallest allowable pipe diameter. Do not use pipe size greater than required or incomplete combustion, flame disturbance, or flame sense lockout may occur.

NOTE: Do not count elbows or pipe sections in terminations or within furnace. See shaded areas in Fig. 30, 31, 32, 33, and 34.

EXAMPLE:
An 036080 size furnace located in Indianapolis, elevation 650 ft above sea level, could be installed in an application requiring 3 elbows and 32 ft of vent pipe, along with 5 elbows and 34 ft of combustion-air pipe. Table 6 indicates this application would allow a 2-in. diameter vent pipe, but require a 2-1/2 in. diameter combustion air pipe (2-in. pipe is good for 35 ft with 3 elbows, but only 30 ft with 5 elbows). Therefore, 2-1/2 in. diameter pipe must be used for both vent and combustion-air pipes since larger required diameter must always be used for both pipes. If same installation were in Albuquerque, elevation 5250 ft above sea level, installation would require 2-1/2 in. vent pipe and combustion-air pipe. At 5001- to 6000-ft elevation, 2-in. pipe is only good for 17 ft with 5 elbows, and 2-1/2 in. pipe is good for 70 ft with 5 elbows.

C. Combustion-Air and Vent Pipe Attachment

NOTE: All pipe joints must be watertight except attachment of combustion-air pipe to inlet housing connection, since it may be necessary to remove pipe for servicing.

1. Attach combustion-air pipe as follows:
 - a. Determine location of combustion-air intake pipe connection to combustion-air intake housing as shown in Fig. 27 for application.
 - b. Reposition combustion-air intake housing plug fitting in appropriate unused intake housing connection.
 - c. If required, insert perforated disk assembly (factory-supplied in loose parts bag) in intake housing where combustion-air intake pipe will be connected. If half disk set is required, install with shoulder of disk against stop in combustion-air inlet.
 - d. Install pipe support (factory-supplied in loose parts bag) into selected furnace casing combustion-air pipe hole. Pipe support should be positioned at bottom of casing hole.
 - e. Insert 2-in. diameter pipe into intake housing.

NOTE: A 2-in. diameter pipe must be used within the furnace casing. Make all pipe diameter transitions outside furnace casing.

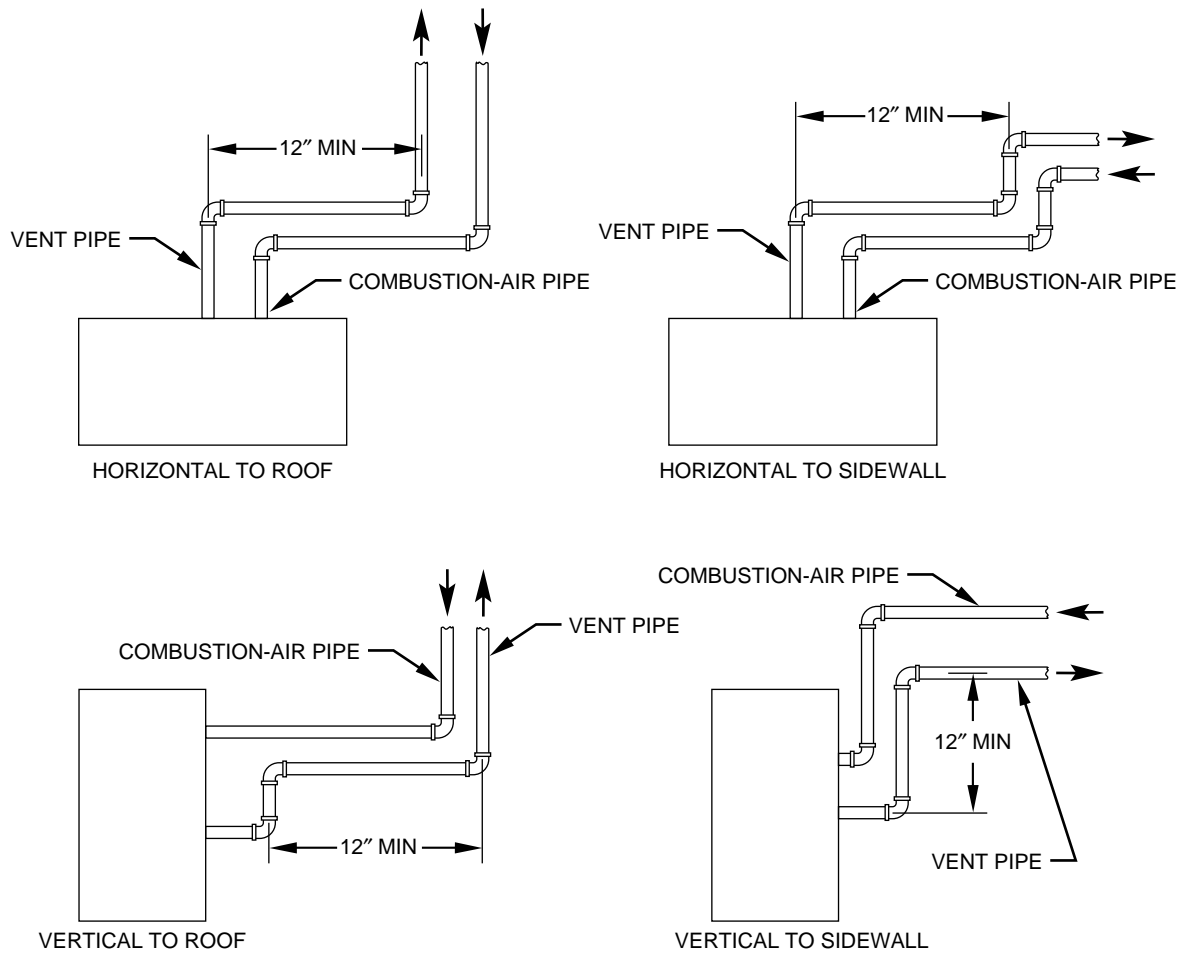

NOTE: A 12 in. minimum offset pipe section is recommended with short (5 to 8 ft) vent systems. This recommendation is to reduce excessive condensate droplets from exiting the vent pipe.

Fig. 28—Short Vent (5 to 8 Ft) System

A96230

- f. Drill a 1/8-in. hole in 2-in. combustion-air pipe using hole in intake housing as a guide.
- g. Install a field-supplied No. 6 or No. 8 sheet metal screw into combustion-air pipe.

NOTE: DO NOT OVERTIGHTEN SCREW. Breakage to intake housing or fitting may cause air leakage to occur.

NOTE: Do not attach combustion-air intake pipe permanently to combustion-air intake housing since it may be necessary to remove pipe for service of ignitor or flame sensor.

COMBUSTION-AIR INTAKE HOUSING PLUG FITTING

The combustion-air intake plug fitting must be installed in unused combustion-air intake housing. This fitting must be attached by using RTV sealant, or by drilling a 1/8-in. hole in fitting, using hole in intake housing as a guide. Install a field-supplied No. 6 or No. 8 sheet metal screw.

NOTE: DO NOT OVERTIGHTEN SCREW. Breakage to intake housing or fitting may cause air leakage to occur.

A plugged drain connection has been provided on this fitting for use when moisture is found in combustion-air intake pipe and combustion box.

NOTE: Moisture in combustion-air intake may be result of improper termination. Ensure combustion-air intake pipe is similar to that shown in Fig. 30, 31, 32, 33, or 34 so it will not be susceptible to areas where light snow or other sources of moisture could be pulled in.

If use of this drain connection is desired, drill out fitting's tap plug with a 3/16-in. drill and connect a field-supplied 3/8-in. tube. This tube should be routed to open condensate drain for furnace and A/C (if used), and should be trapped. (See Fig. 29.)

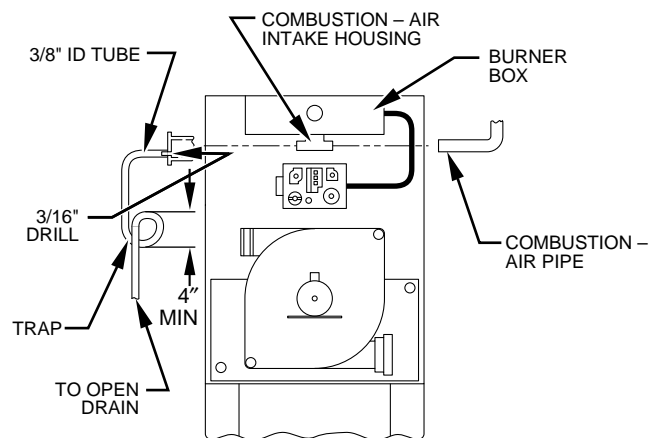

Fig. 29—Intake Housing Plug Fitting Drain

A93035

2. Attach vent pipe as follows:
 - a. Determine location of vent pipe connection to inducer housing as shown in Fig. 27 for application.

TABLE 6—MAXIMUM ALLOWABLE PIPE LENGTH (FT)

ALTITUDE	UNIT SIZE	TERMINATION TYPE	PIPE DIA (IN.)*	NUMBER OF 90° ELBOWS						
				1	2	3	4	5	6	
0 to 2000	024040 036040	2 Pipe or 2-In. Concentric	1	5	NA	NA	NA	NA	NA	NA
			1-1/2	70	70	65	60	60	55	
			2	70	70	70	70	70	70	
	024060 036060 048060	2 Pipe or 2-In. Concentric	1-1/2	20	15	10	5	NA	NA	
			2	70	70	70	70	70	70	
	036080 048080 060080	2 Pipe or 2-In. Concentric	1-1/2	10	NA	NA	NA	NA	NA	
			2	55	50	35	30	30	20	
			2-1/2	70	70	70	70	70	70	
	048100 060100	2 Pipe or 3-In. Concentric	2	5	NA	NA	NA	NA	NA	
			2-1/2	40	30	20	20	10	NA	
			3	70	70	70	70	70	70	
	→060120	2 Pipe or 3-In. Concentric	2-1/2 one disk	10	NA	NA	NA	NA	NA	
			3†	45	40	35	30	25	20	
			3† no disk	70	70	70	70	70	70	
	→060140	2 Pipe or 3-In. Concentric	4† no disk	70	70	70	70	70	70	
			2-1/2 one disk	5	NA	NA	NA	NA	NA	
3† one disk			40	35	30	25	20	15		
3† no disk			60	56	52	48	44	40		
			4† no disk	70	70	70	70	70	70	
ALTITUDE	UNIT SIZE	TERMINATION TYPE	PIPE DIA (IN.)*	NUMBER OF 90° ELBOWS						
				1	2	3	4	5	6	
2001 to 3000	024040 036040	2 Pipe or 2-In. Concentric	1-1/2	67	62	57	52	52	47	
			2	70	70	70	70	70	70	
	024060 036060 048060	2 Pipe or 2-In. Concentric	1-1/2	17	12	7	NA	NA	NA	
			2	70	67	66	61	61	61	
	036080 048080 060080	2 Pipe or 2-In. Concentric	2	49	44	30	25	25	15	
			2-1/2	70	70	70	70	70	70	
	048100 060100	2 Pipe or 3-In. Concentric	2-1/2	35	26	16	16	6	NA	
			3	70	70	70	70	66	61	
	→060120	2 Pipe or 3-In. Concentric	3	14	9	NA	NA	NA	NA	
			3† no disk	70	70	63	56	50	43	
			4† no disk	70	70	70	70	70	70	
	→060140	2 Pipe or 3-In. Concentric	3† one disk	20	15	10	5	NA	NA	
3† no disk			39	35	31	27	23	19		
4† no disk			70	70	70	70	70	70		
ALTITUDE	UNIT SIZE	TERMINATION TYPE	PIPE DIA (IN.)*	NUMBER OF 90° ELBOWS						
				1	2	3	4	5	6	
3001 to 4000	024040 036040	2 Pipe or 2-In. Concentric	1-1/2	64	59	54	49	48	43	
			2	70	70	70	70	70	70	
	024060 036060 048060	2 Pipe or 2-In. Concentric	1-1/2	16	11	6	NA	NA	NA	
			2	68	63	62	57	57	56	
	036080 048080 060080	2 Pipe or 2-In. Concentric	2	46	41	28	23	22	13	
			2-1/2	70	70	70	70	70	70	
	048100 060100	2 Pipe or 3-In. Concentric	2-1/2	33	24	15	14	5	NA	
			3	70	70	70	66	61	56	
	→060120	2 Pipe or 3-In. Concentric	3† no disk	65	58	51	44	38	31	
			4† no disk	70	70	70	70	70	70	
	→060140	2 Pipe or 3-In. Concentric	3† one disk	11	6	NA	NA	NA	NA	
			3† no disk	30	26	22	18	14	10	
4† no disk			70	70	70	70	70	70		

See notes on page 26.

TABLE 6—MAXIMUM ALLOWABLE PIPE LENGTH (FT) Continued

ALTITUDE	UNIT SIZE	TERMINATION TYPE	PIPE DIA (IN.)*	NUMBER OF 90° ELBOWS					
				1	2	3	4	5	6
4001 to 5000‡	024040 036040	2 Pipe or 2-In. Concentric	1-1/2	60	55	50	45	44	39
			2	70	70	70	70	70	70
	024060 036060 048060	2 Pipe or 2-In. Concentric	1-1/2	15	10	5	NA	NA	NA
			2	64	59	58	53	52	52
	036080 048080 060080	2 Pipe or 2-In. Concentric	2	44	39	26	21	20	11
			2-1/2	70	70	70	70	70	70
	048100 060100	2 Pipe or 3-In. Concentric	2-1/2	31	22	13	12	NA	NA
			3	70	70	67	62	57	52
→060120	2 Pipe or 3-In. Concentric	3† no disk	53	46	40	33	26	20	
		4† no disk	70	70	70	70	70	70	
→060140	2 Pipe or 3-In. Concentric	3† no disk	21	17	13	9	5	NA	
		4† no disk	69	64	59	54	49	44	
5001 to 6000‡	024040 036040	2 Pipe or 2-In. Concentric	1-1/2	57	52	47	42	40	35
			2	70	70	70	70	70	70
024060 036060 048060	2 Pipe or 2-In. Concentric	1-1/2	14	9	NA	NA	NA	NA	
		2	60	55	54	49	48	47	
036080 048080 060080	2 Pipe or 2-In. Concentric	2	41	36	23	18	17	8	
		2-1/2	70	70	70	70	70	70	
048100 060100	2 Pipe or 3-In. Concentric	2-1/2	29	21	12	11	NA	NA	
		3	70	67	62	57	52	47	
→060120	2 Pipe or 3-In. Concentric	3† no disk	42	35	29	22	15	9	
		4† no disk	70	70	70	70	70	70	
→060140	2 Pipe or 3-In. Concentric	3† no disk	12	8	NA	NA	NA	NA	
		4† no disk	42	37	32	27	22	17	
6001 to 7000‡	024040 036040	2 Pipe or 2-In. Concentric	1-1/2	53	48	43	38	37	32
			2	70	70	68	67	66	64
024060 036060 048060	2 Pipe or 2-In. Concentric	1-1/2	13	8	NA	NA	NA	NA	
		2	57	52	50	45	44	43	
036080 048080 060080	2 Pipe or 2-In. Concentric	2	38	33	21	16	15	6	
		2-1/2	70	70	68	67	66	64	
048100 060100	2 Pipe or 3-In. Concentric	2-1/2	27	19	10	9	NA	NA	
		3	68	63	58	53	48	43	
→060120	2 Pipe or 3-In. Concentric	3† no disk	31	24	18	11	NA	NA	
		4† no disk	70	70	70	70	67	62	
→060140	2 Pipe or 3-In. Concentric	4† no disk	17	12	7	NA	NA	NA	
7001 to 8000‡	024040 036040	2 Pipe or 2-In. Concentric	1-1/2	49	44	39	34	33	28
			2	66	65	63	62	60	59
024060 036060 048060	2 Pipe or 2-In. Concentric	1-1/2	12	7	NA	NA	NA	NA	
		2	53	48	46	41	40	38	
036080 048080 060080	2 Pipe or 2-In. Concentric	2	36	31	19	14	12	NA	
		2-1/2	66	65	63	62	60	59	
048100 060100	2 Pipe or 3 In. Concentric	2-1/2	25	17	8	7	NA	NA	
		3	63	58	53	48	43	38	
→060120	2 Pipe or 3-In. Concentric	3† no disk	20	13	7	NA	NA	NA	
		4† no disk	61	56	51	46	41	36	
→060140			NA						

See notes on page 26.

TABLE 6—MAXIMUM ALLOWABLE PIPE LENGTH (FT) Continued

ALTITUDE	UNIT SIZE	TERMINATION TYPE	PIPE DIA (IN.)*	NUMBER OF 90° ELBOWS					
				1	2	3	4	5	6
8001 to 9000‡	024040 036040	2 Pipe or 2-In. Concentric	1-1/2	46	41	36	31	29	24
			2	62	60	58	56	55	53
	024060 036060 048060	2 Pipe or 2-In. Concentric	1-1/2	11	6	NA	NA	NA	NA
			2	49	44	42	37	35	34
	036080 048080 060080	2 Pipe or 2-In. Concentric	2	33	28	17	12	10	NA
			2-1/2	62	60	58	56	55	53
	048100 060100	2 Pipe or 3-In. Concentric	2-1/2	23	15	7	5	NA	NA
3			59	54	49	44	39	34	
→060120	2 Pipe or 3-In. Concentric	3† no disk	10	NA	NA	NA	NA	NA	
		4† no disk	35	30	25	20	15	10	
	→060140		NA						
ALTITUDE	UNIT SIZE	TERMINATION TYPE	PIPE DIA (IN.)*	NUMBER OF 90° ELBOWS					
				1	2	3	4	5	6
9001 to 10,000‡	024040 036040	2 Pipe or 2-In. Concentric	1-1/2	42	37	32	27	25	20
			2	57	55	53	51	49	47
	024060 036060 048060	2 Pipe or 2-In. Concentric	2	45	40	38	33	31	29
			2	30	25	14	9	7	NA
	036080 048080 060080	2 Pipe or 2-In. Concentric	2-1/2	57	55	53	51	49	47
			2-1/2	21	13	5	NA	NA	NA
	048100 060100	2 Pipe or 3-In. Concentric	3	54	49	44	39	34	29
4† no disk			10	5	NA	NA	NA	NA	
	→060140		NA						

* Disk usage—Unless otherwise specified, use perforated disk assembly (factory-supplied in loose parts bag). If one disk is stated, separate 2 halves of perforated disk assembly and use shouldered disk half. When using shouldered disk half, install screen side toward inlet box.

† Wide radius elbow.

‡ Vent sizing for Canadian installations over 4500 ft (1370 m) above sea level are subject to acceptance by the local authorities having jurisdiction.

NA—Not Allowed; pressure switch will not make.

NOTES:

1. Do not use pipe size greater than those specified in table or incomplete combustion, flame disturbance, or flame sense lockout may occur.
2. Size both the combustion-air and vent pipe independently, then use the larger diameter for both pipes.
3. Assume two 45° elbows equal one 90° elbow. Long radius elbows are desirable and may be required in some cases.
4. Elbows and pipe sections within the furnace casing and at the vent termination should not be included in vent length or elbow count.
5. The minimum pipe length is 5 ft for all applications.
6. Use 3-in. diameter vent termination kit for installations requiring 4-in diameter pipe.

- b. Reposition neoprene inducer housing outlet cap and clamp to appropriate unused inducer housing connection. Tighten clamp.

⚠	WARNING: Inducer housing outlet cap must be installed and fully seated against inducer housing. Clamp must be tightened to prevent any condensate leakage. Failure to follow this warning could result in electrical shock, fire, personal injury, or death.
---	---

- c. Install pipe support (factory-supplied in loose parts bag) into selected furnace casing vent pipe hole. Pipe support should be positioned at bottom of casing hole.
- d. Insert 2-in. diameter pipe into inducer housing through neoprene coupling and clamp in inducer housing. Tighten clamp.

⚠	WARNING: Vent pipe must be installed and fully seated against inducer housing. Clamp must be tightened to prevent any condensate leakage. Failure to follow this warning could result in electrical shock, fire, personal injury, or death.
---	--

VENT EXTENSION PIPE

Some furnaces are supplied with a PVC vent extension pipe (2-in. diameter by 12-in. long). This pipe has a built-in channel to assist vent condensate disposal. When this vent extension pipe is supplied, it must be used to connect the field vent pipe to furnace inducer housing on ALL upflow and downflow applications.

NOTE: See label on vent extension pipe for proper installation. This pipe may be shortened if an elbow is used to connect vent extension tube to field-installed vent pipe.

3. Working from furnace to outside, cut pipe to required length(s).
4. Deburr inside and outside of pipe.
5. Chamfer outside edge of pipe for better distribution of primer and cement.
6. Clean and dry all surfaces to be joined.
7. Check dry fit of pipe and mark insertion depth on pipe.

NOTE: It is recommended that all pipes be cut, prepared, and preassembled before permanently cementing any joint.

8. After pipes have been cut and preassembled, apply generous layer of cement primer to pipe fitting socket and end of pipe to insertion mark. Quickly apply approved cement to end of pipe and fitting socket (over primer). Apply cement in a light, uniform coat on inside of socket to prevent buildup of excess cement. Apply second coat.

NOTE: A 2-in. diameter pipe must be used within the furnace casing. Make all pipe diameter transitions outside furnace casing.

9. While cement is still wet, twist pipe into socket with 1/4 turn. Be sure pipe is fully inserted into fitting socket.
10. Wipe excess cement from joint. A continuous bead of cement will be visible around perimeter of a properly made joint.
11. Handle pipe joints carefully until cement sets.
12. Support combustion-air and vent piping a minimum of every 5 ft (3 ft for SDR-21 or -26 PVC) using perforated metal hanging strap.
13. Slope combustion-air and vent pipes toward furnace a minimum of 1/4 in. per linear ft with no sags between hangers.
14. Use appropriate methods to seal openings where vent and combustion-air pipes pass through roof or side wall.

III. CONCENTRIC VENT AND COMBUSTION-AIR TERMINATION KIT INSTALLATION

NOTE: If these instructions differ from those packaged with termination kit, follow kit instructions.

Combustion-air and vent pipes must terminate outside structure. A factory accessory termination kit must be installed in 1 of the installations shown in Fig. 30, 31, 32, 33, or 34. Four termination kits are available.

1. The 2-in. termination bracket kit is for 1-in., 1-1/2 in., and 2-in. diameter 2-pipe termination systems.
- 2. The 3-in. termination bracket kit is for 2-1/2 in., 3-in., and 4-in. diameter 2-pipe termination systems.
3. The 2-in. concentric vent/air termination kit is for 1-in., 1-1/2 in., 2-in., and 2-1/2 in. diameter pipe systems when single penetration of wall or roof is desired.
- 4. The 3-in. concentric vent/air termination kit is for 2-1/2 in., 3-in., and 4-in. diameter pipe systems when single penetration of wall or roof is desired.

NOTE: Shaded parts in Fig. 30, 31, 32, 33, and 34 are considered to be termination. These components should NOT be counted when determining pipe diameter. Roof termination is preferred since it is less susceptible to damage, has reduced chances to take

in contaminants, and has less visible vent vapors. (See Fig. 30 or 31.) Sidewall termination may require sealing or shielding of building surfaces with a corrosive resistance material due to corrosive combustion products of vent system.

A. Extended Exposed Sidewall Pipes

Sidewall combustion-air and vent pipe terminations may be extended beyond area shown in Fig. 33 or 34 in outside ambient by insulating pipes as indicated in Table 7.

1. Determine combustion-air and vent pipe diameters, as stated above, using total pipe length and number of elbows.
2. Using winter design temperature (used in load calculations), find appropriate temperature for your application and furnace model.
3. Determine required insulation thickness for exposed pipe lengths.

NOTE: Pipe length (ft) specified for maximum pipe lengths located in unconditioned spaces cannot exceed total allowable pipe length as specified in Table 6.

B. Two-Pipe Termination Kit

1. Determine location for termination.

Consideration of the following should be made when determining an appropriate location for termination kit.

 - a. Comply with all clearance requirements as stated in Table 5.
 - b. Termination kit should be positioned where vent vapors will not damage plants/shrubs or air conditioning equipment.
 - c. Termination kit should be positioned so that it will not be affected by wind eddy (such as inside building corners) or allow recirculation of flue gases, airborne leaves, or light snow.
 - d. Termination kit should be positioned where it will not be damaged by or subjected to foreign objects, such as stones, balls, etc.
 - e. Termination kit should be positioned where vent vapors are not objectionable.

→ **TABLE 7—MAXIMUM ALLOWABLE EXPOSED VENT PIPE LENGTH (FT) WITH AND WITHOUT INSULATION IN WINTER DESIGN TEMPERATURE AMBIENT***

UNIT SIZE	WINTER DESIGN TEMPERATURE (°F)	MAX PIPE DIAMETER (IN.)	WITHOUT INSULATION	WITH 3/8-IN. OR THICKER INSULATION†
040	20	1-1/2	51	70
	0	1-1/2	28	70
	-20	1-1/2	16	70
060	20	2	65	70
	0	2	35	70
	-20	2	20	70
080	20	2-1/2	70	70
	0	2-1/2	47	70
	-20	2-1/2	28	70
100	20	3	70	70
	0	3	50	70
	-20	3	28	70
120	20	4	70	70
	0	4	48	70
	-20	4	23	70
140	20	4	70	70
	0	4	57	70
	-20	4	30	70

* Pipe length (ft) specified for maximum pipe lengths located in unconditioned spaces. Pipes located in unconditioned space cannot exceed total allowable pipe length as specified in Table 6.

† Insulation thickness based on R value of 3.5 per in.

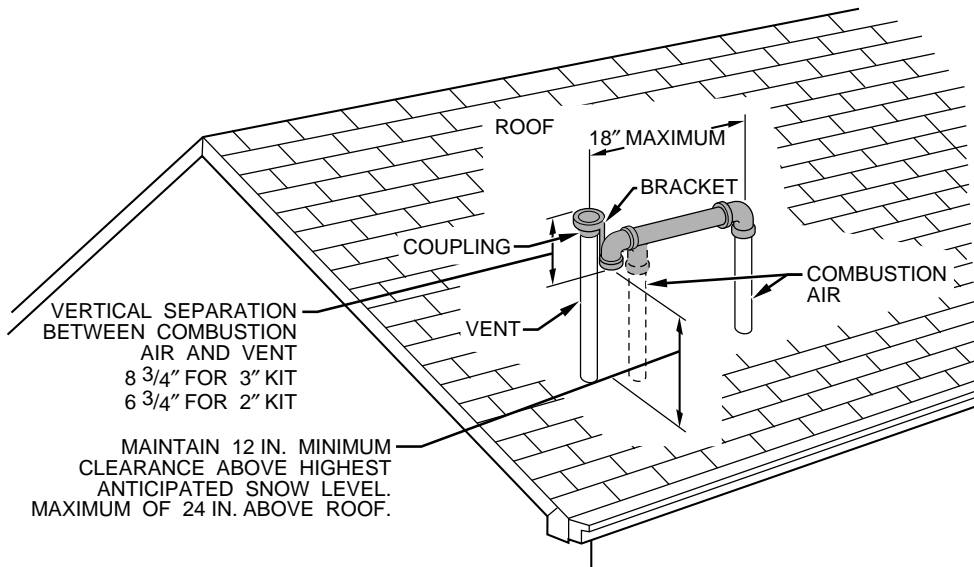
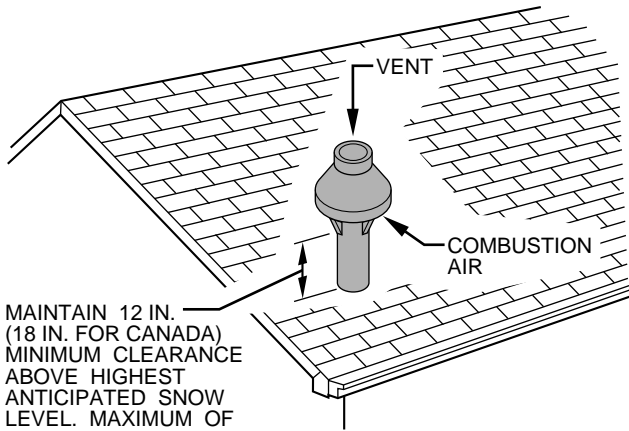
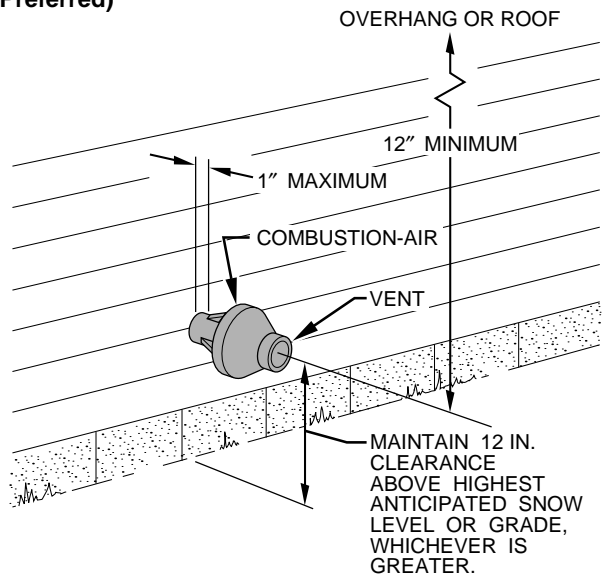

Fig. 30—Roof Termination (Preferred)



A93054

Fig. 31—Concentric Vent and Combustion-Air Roof Termination (Preferred)



A93055

Fig. 32—Concentric Vent and Combustion-Air Side Termination

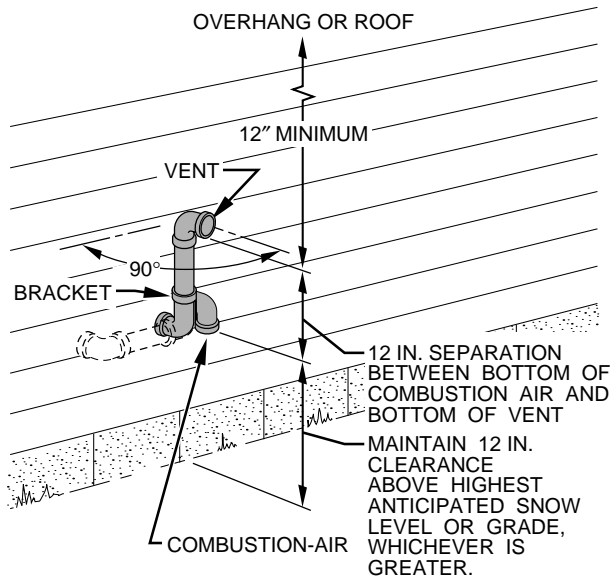

A87225

Fig. 33—Sidewall Termination of 12 in. or More

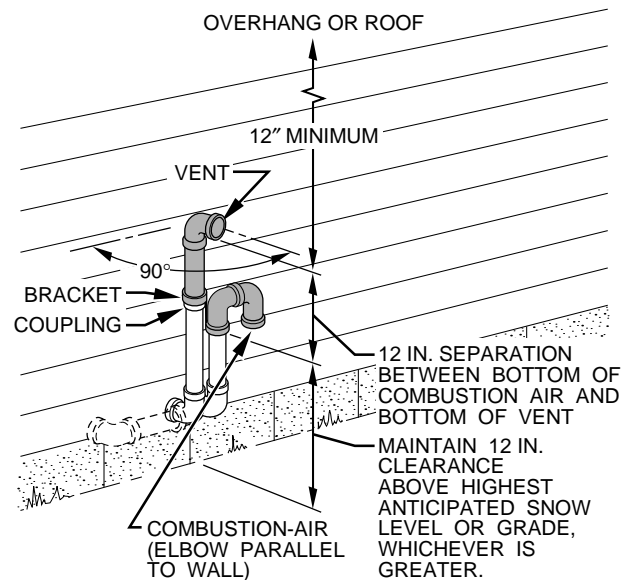

A87226

Fig. 34—Sidewall Termination of Less than 12 in.

- Cut 2 holes, 1 for each pipe, of appropriate size for pipe size being used.
- Loosely install elbow in bracket and place assembly on combustion-air pipe.

Roof terminations—Loosely install pipe coupling on properly cut vent pipe. Coupling must be positioned so bracket will mount as shown in Fig. 30.

For applications using combustion-air pipe option, indicated by dashed lines in Fig. 30, install 90° street elbow into 90° elbow, making U-fitting. A 180° U-fitting may be used.

Sidewall terminations—Install bracket as shown in Fig. 33 or 34.

For applications using vent pipe option indicated by dashed lines in Fig. 33, rotate vent elbow 90° from position shown in Fig. 33.

- Disassemble loose pipe fittings. Clean and cement using same procedures as used for system piping.
- Check required dimensions as shown in Fig. 30, 33, or 34.

C. Concentric Vent/Air Termination Kit

- Determine location for termination.

Consideration of the following should be made when determining an appropriate location for termination kit.

- Comply with all clearance requirements as stated in Table 5.
- Termination kit should be positioned where vent vapors will not damage plants/shrubs or air conditioning equipment.
- Termination kit should be positioned so it will not be affected by wind eddy (such as inside building corners) or that may allow recirculation of flue gases, airborne leaves, or light snow.
- Termination kit should be positioned where it will not be damaged by or subjected to foreign objects, such as stones, balls, etc.
- Termination kit should be positioned where vent vapors are not objectionable.

- Cut one 4-in. diameter hole for 2-in. kit, or one 5-in. diameter hole for 3-in. kit.
- Loosely assemble concentric vent/air termination components together using instructions in kit.
- Slide assembled kit with rain shield REMOVED through hole.

NOTE: Do not allow insulation or other materials to accumulate inside of pipe assembly when installing it through hole.

Roof terminations—Locate assembly through roof to appropriate height as shown in Fig. 31.

Sidewall terminations—Locate assembly through sidewall with rain shield positioned no more than 1-in. from wall as shown in Fig. 32.

- Disassemble loose pipe fittings. Clean and cement using same procedures as used for system piping.
- Check required dimensions as shown in Fig. 31 or 32.

IV. MULTIVENTING AND VENT TERMINATIONS

When 2 or more 340MAV Furnaces are vented near each other, each furnace must be individually vented. NEVER common vent or breach vent 340MAV furnaces. When 2 or more 340MAV furnaces are vented near each other, 2 vent terminations may be installed as shown in Fig. 35, 36, 37, 38, or 39, but next vent

termination must be at least 36 in. away from first 2 terminations. It is important that vent terminations be made as shown to avoid recirculation of flue gases. Dimension "A" in Fig. 35, 36, 37, 38, and 39 represents distance between pipes or rain shields, as touching or 2-in. maximum separation.

CONDENSATE DRAIN

I. GENERAL

Condensate trap is shipped installed in the blower shelf and factory connected for UPFLOW applications. Condensate trap must be RELOCATED for use in DOWNFLOW and HORIZONTAL applications.

Condensate trap MUST be used for all applications.

An external trap is not required when connecting the field drain to this condensate trap.

The field drain connection (condensate trap or drain tube coupling) is sized for 1/2-in. CPVC, 1/2-in. PVC, or 5/8-in. ID tube connection.

Drain pipe and fittings must conform to ANSI standards and ASTM D1785 or D2846. CPVC or PVC cement and primer must conform to ASTM D2564 or F493. In Canada, use CSA or ULC certified schedule 40 CPVC or PVC drain pipe, fittings, and cement.

When a condensate pump is required, select a pump which is approved for condensing furnace applications. To avoid condensate spillage, select a pump with an overflow switch.

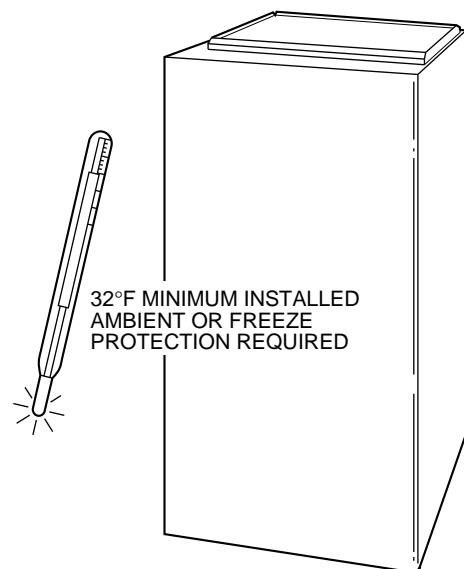

A93058

CAUTION: Unit must not be installed, operated, and then turned off and left in an unoccupied structure during cold weather when temperature drops to 32°F and below unless drain trap and drain line have adequate freeze protection. See Service and Maintenance Instructions for winterizing procedure.

Furnace condensate is mildly acidic, typically in the pH range of 3.2 to 4.5. Due to corrosive nature of this condensate, a condensate pH neutralizing filter may be desired. Check with local authorities to determine if a pH neutralizer is required.

II. APPLICATION

The furnace, A/C, and humidifier drains may be combined and drained together. The A/C drain must have an external, field-supplied trap prior to the furnace drain connection. All drain connections (furnace, A/C, or humidifier) must be terminated into an open or vented drain as close to the respective equipment as possible to prevent siphoning of the equipment's drain.

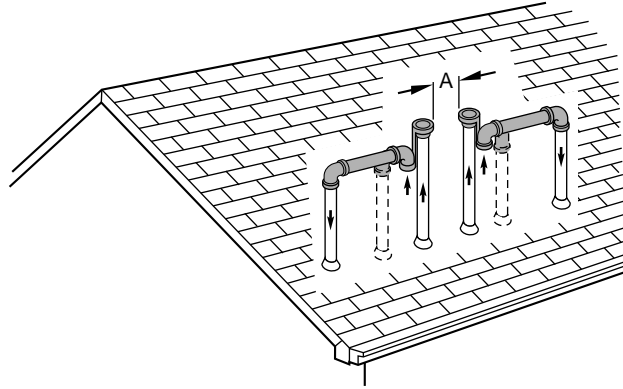

Fig. 35—Rooftop Termination (Dimension "A" is Touching or 2-In. Maximum Separation)

A96128

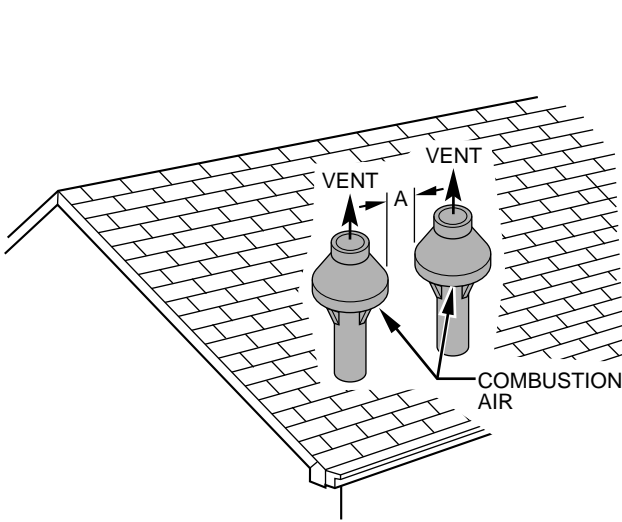

Fig. 36—Concentric Vent and Combustion-Air Roof Termination (Dimension "A" is Touching or 2-In. Maximum Separation)

A93056

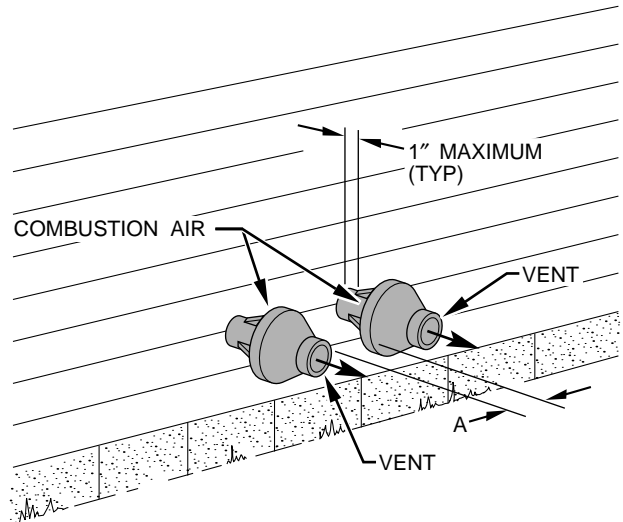

Fig. 37—Concentric Vent and Combustion-Air Side Termination (Dimension "A" is Touching or 2-In. Maximum Separation)

A93057

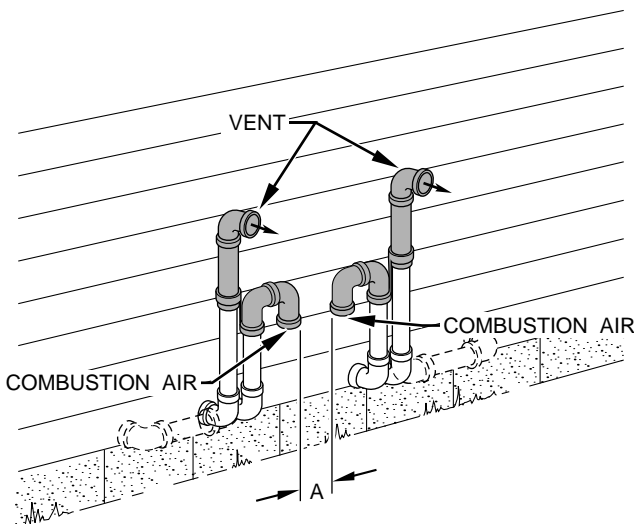

Fig. 38—Sidewall Termination of 12 in. or Less (Dimension "A" is Touching or 2-In. Maximum Separation)

A96129

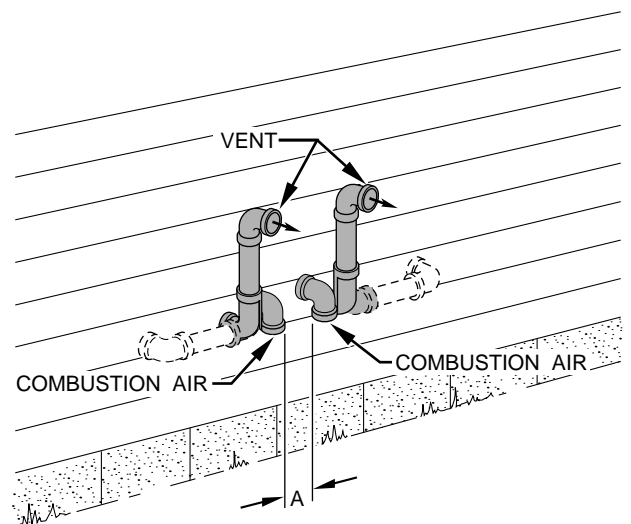
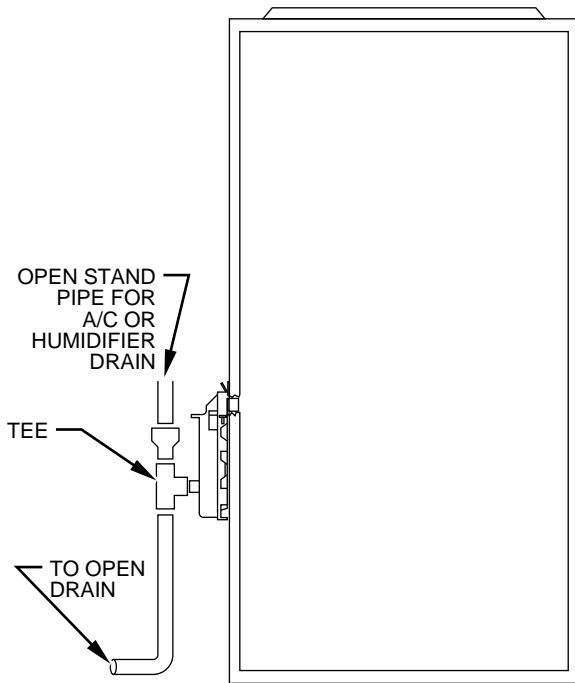

Fig. 39—Sidewall Termination of More Than 12 in. (Dimension "A" is Touching or 2-In. Maximum Separation)

A96130

See Fig. 40 for example of possible field drain attachment using 1/2-in. CPVC or PVC tee for vent and A/C or humidifier drain connection.



A94054

Fig. 40—Example of Field Drain Attachment

Outdoor draining of the furnace is permissible if allowed by local codes. Caution should be taken when freezing ambient may freeze drain pipe and prohibit draining.

⚠	WARNING: Caution should be taken to prevent draining where slippery conditions may cause personal injuries. Excessive condensate draining may cause saturated soil conditions which may result in damage to plants.
---	--

III. CONDENSATE DRAIN PROTECTION

Freezing condensate left in condensate trap and drain line may cause cracks, and possible water damage may occur. If freeze protection is required, use condensate freeze protection accessory or equivalent 3 to 6 watt per ft at 120v and 40°F self-regulating, shielded, and waterproof heat tape. See Installation Instructions supplied with accessory or heat tape manufacturer's recommendations.

1. Fold heat tape in half and wrap on itself 3 times.
2. Locate heat tape between sides of condensate trap back. (See Fig. 41.)
3. Use wire ties to secure heat tape in place. Wire ties can be positioned in notches of condensate trap sides. (See Fig. 41.)
4. Wrap field drain pipe with remaining heat tape, approximately 1 wrap per ft.
5. When using field-supplied heat tape, follow heat tape manufacturer's instructions for all other installation guidelines.

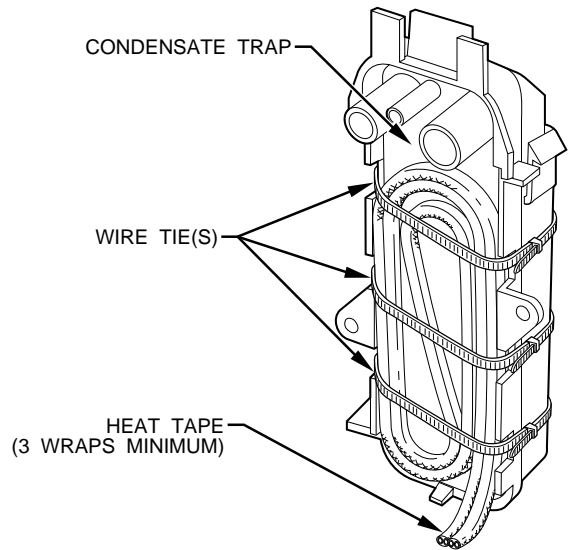

A93036

Fig. 41—Condensate Trap Heat Tape
SEQUENCE OF OPERATION

⚠	CAUTION: Furnace control must be grounded for proper operation, or control will lock out. Control is grounded through green wire routed to gas valve and burner box screw.
---	---

Using schematic diagram, follow sequence of operation through different modes. (See Fig. 24.) Read and follow wiring diagram carefully.

NOTE: If 115-v power supply to furnace or blower access panel switch is interrupted during a call for heat, blower operates for 90 sec when power is restored before heating cycle is resumed.

I. HEATING MODE

When wall thermostat calls for heat, R-W circuit closes. Furnace control performs a self-check, verifies pressure switch contacts are open, and starts inducer motor.

1. **Prepurge period**—As inducer motor comes up to speed, pressure switch contacts close to begin a 15-sec prepurge period.
2. **Ignitor warm up**—At end of prepurge period, ignitor is energized for a 17-sec ignitor warm-up period.
3. **Ignition sequence**—When ignitor warm-up period is completed, gas valve opens, permitting gas flow to burners where it is ignited. After 5 sec, ignitor is de-energized and a 2-sec flame-sensing period begins.

HUM terminal on control center is energized with gas valve. See Accessories — Humidifier section.

4. **Flame sensing**—When burner flame is sensed, control begins blower on delay period and continues holding gas valve open.

If burner flame is not sensed, control center de-energizes gas valve and ignition sequence is repeated.

NOTE: Ignition sequence repeats 3 additional times before a lockout occurs. Lockout automatically resets after 3 hr or can be manually reset by turning off 115v (not at thermostat) for 3 sec minimum, then turning it on again.

-
5. **Blower on delay**—Sixty sec after burner flame is proven (40 sec if jumper has been cut for 140 size unit in downflow orientation), blower motor is energized on heating speed. Simultaneously, electronic air cleaner terminal EAC-1 is energized.

6. **Blower off delay**—When thermostat is satisfied, circuit between R-W is opened, de-energizing gas valve (stopping gas flow to burners) and humidifier. Blower motor and electronic air cleaner remain energized for 135 sec.

→ 7. **Post purge**—Inducer motor remains energized 15 sec after burners are extinguished (5 sec if jumper has been cut for 140 size unit in downflow orientation).

II. COOLING MODE

When thermostat calls for cooling, R-G and R-Y circuits close. R-Y circuit starts outdoor condensing unit, and combined R-Y and R-G circuit starts furnace blower motor on cooling speed. Electronic air cleaner EAC-1 terminal is energized with 115v whenever blower is operating.

When thermostat is satisfied, R-G and R-Y circuits are opened, furnace blower continues operating on cooling speed for an additional 90 sec.

III. CONTINUOUS BLOWER MODE

When R-G circuit is made, blower motor operates on heating speed.

NOTE: Electronic air cleaner EAC-1 terminal is energized with 115v whenever blower is operating.

→ If a call for heat (R-W) occurs while thermostat is in continuous blower mode, blower stops to allow furnace heat exchangers to heat up more quickly, then restarts at end of blower on delay period of 60 sec (40 sec if jumper has been cut for 140 size unit in downflow orientation).

Blower reverts to continuous operation after heating cycle is completed.

If a call for cooling (R-Y) occurs while thermostat is in continuous blower mode, blower changes from continuous blower speed (heating speed) to cooling speed.

When thermostat cooling call is satisfied, R-Y opens and blower operates an additional 90 sec at cooling speed before reverting back to continuous operation (heating speed).

IV. HEAT PUMP MODE

When installed with a heat pump, furnace control automatically changes blower on delay timing sequence to avoid no blower operation time during demand defrost cycles. When R-W and R-Y or R-W, R-Y, and R-G thermostat inputs are received at the same time at furnace control center, control starts blower in heating speed. Then a gas heat mode begins. Blower remains operating at heating speed for 15 sec or until end of prepurge period, then blower shuts off until end of ignitor warm up and trial for ignition periods (a total of 24 sec). Blower restarts at heating speed.

→ When R-W thermostat call disappears, control completes inducer post-purge period of 15 sec (5 sec if jumper has been cut for 140 size unit in downflow orientation) and changes to cooling speed after a 2-sec delay.

→ If R-W, R-Y, and R-G thermostat signals should disappear simultaneously, blower remains on for heating blower off delay period of 135 sec, and the inducer goes through 15 sec post-purge period (5 sec if jumper has been cut for 140 size unit in downflow orientation). If R-W and R-Y thermostat signals should disappear, leaving R-G thermostat signal, blower remains on in heating speed and inducer remains on for 15 sec to complete post-purge period (5 sec if jumper has been cut for 140 size unit in downflow orientation).

Control initiates a 90-sec blower only on period before starting another heat pump cycle if there is a power interruption. Anytime control senses false flame, control locks out of heating mode. This reaction occurs because control ignores W input due to false flame signal and, as a result, sees only Y input and goes into cooling mode blower off delay. All other control functions remain in standard format.

NOTE: EAC-1 terminal is energized whenever blower operates. HUM terminal is only energized when gas valve is energized.

V. COMPONENT TEST

A. Component Test Sequence

NOTE: All components are functionally operated except the gas valve.

When component test is initiated, the following sequence of events occurs:

1. LED flashes a status code 4 times.
2. Inducer motor starts and continues to run for remainder of component test.
3. Hot surface ignitor is energized for 15 sec, then de-energized.
4. Main blower operates at cooling speed for 10 sec, then turns off.
5. Main blower operates at heating speed for 10 sec, then turns off.
6. Inducer motor stops.

Component test can be initiated by one of the following procedures.

B. Initiating Component Test By Removing Main Limit Switch Wire

NOTE: NO thermostat signal may be present at control center and all blower time delay off periods must be completed.

1. Leave 115-v power to furnace turned on.
2. Remove main furnace door.
3. Look into blower access panel sight glass for current LED status.

NOTE: Leave blower access panel installed to maintain power to control center to view current LED status.

4. BRIEFLY remove either wire from the main limit switch until the LED goes out, then reconnect it.

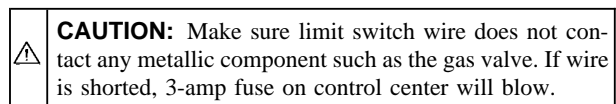

NOTE: If wire to main limit is disconnected longer than 4 sec, the control senses limit circuit is open. Main blower will start, and status code retrieval request will be ignored.

5. When above items have been completed, the component test sequence will occur as described in the Component Test Sequence section above.

NOTE: Be sure to record the status code which is flashed 4 times at start of component test for further troubleshooting.

6. After component test is completed and LED is ON continuously indicating the furnace is ready to operate when a signal from the thermostat is received, replace main furnace door.

C. Initiating Component Test By Jumpering Control TEST Terminal

1. Remove main furnace door.
2. Remove blower access panel.
3. Manually close blower access panel door switch. Use a piece of tape to hold switch closed.

WARNING: Blower access panel door switch opens 115-v power to control center. No component operation can occur. Caution must be taken when manually closing this switch for service purposes. Failure to follow this warning could result in electrical shock, personal injury, or death.

4. BRIEFLY short (jumper) TEST, 1/4-in. quick-connect terminal on control center (adjacent to the LED diagnostic light) and the COM terminal on thermostat connection block. (See Fig. 25.)

NOTE: If TEST to COM terminals are jumpered longer than 2 sec, LED will flash rapidly, and retrieval request will be ignored.

5. When above items have been completed, the component test sequence will occur as described in the Component Test Sequence section above.

NOTE: Be sure to record the status code which is flashed 4 times at start of component test for further troubleshooting.

6. After component test is completed and furnace is operating properly, release blower access panel door switch, replace blower access panel, and replace main furnace door.

START-UP PROCEDURES

I. GENERAL

1. Furnace must have a 115-v power supply properly connected and grounded. Proper polarity must be maintained for correct operation.

NOTE: Proper polarity must be maintained for 115-v wiring. If polarity is incorrect, control center LED status light will flash rapidly and furnace will not operate.

2. Thermostat wire connections at terminals R, W, G, and Y must be made at 24-v terminal block on control center.
3. Natural gas service pressure must not exceed 0.5 psig (14-in. wc), but must be no less than 0.16 psig (4.5-in. wc).
4. Blower access panel must be in place to complete 24-v electrical circuit to furnace.

CAUTION: These furnaces are equipped with a manual reset limit switch in burner box. This switch will open if an overheat condition (rollout) occurs in burner enclosure. Correct inadequate combustion-air supply or improper venting condition and reset switch. DO NOT jumper this switch.

Before operating furnace, check each manual reset switch for continuity. If necessary, press button to reset switch.

II. PRIME CONDENSATE TRAP WITH WATER

CAUTION: Condensate trap must be PRIMED or proper draining may not occur. The condensate trap has 2 internal chambers which can ONLY be primed by pouring water into the inducer drain side of condensate trap.

1. Remove upper inducer housing drain connection cap. (See Fig. 42.)
2. Connect field-supplied 1/2-in. ID tube to upper inducer housing drain connection.
3. Insert field-supplied funnel into tube.
4. Pour 1 quart of water into funnel/tube. Water should run through inducer housing, overflow condensate trap, and flow into open field drain. (See Fig. 43.)

5. Remove funnel and tube from inducer housing and replace drain connection cap and clamp.

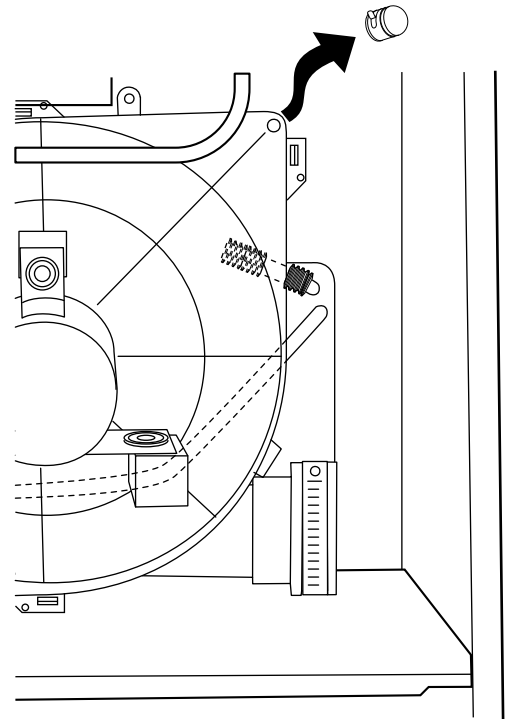

Fig. 42—Inducer Housing Drain Tube

A94208

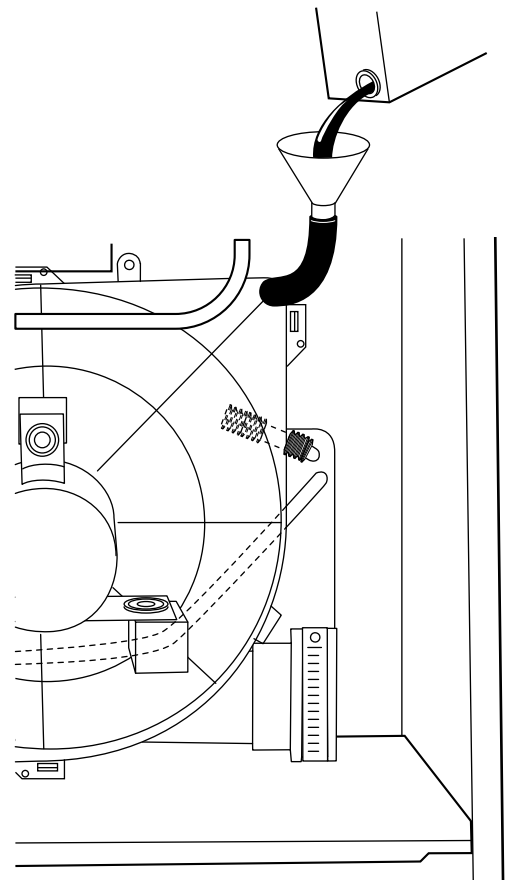

Fig. 43—Filling Condensate Trap

A94209

III. PURGE GAS LINES

If not previously done, purge lines after all connections have been made and check for leaks.

WARNING: Never purge a gas line into a combustion chamber. Never use matches, candles, flame, or other sources of ignition for purpose of checking leakage. Use a soap-and-water solution to check for leakage. Failure to follow this warning could result in fire, explosion, personal injury, or death.

IV. ADJUSTMENTS

A. Set Gas Input Rate

Furnace gas input rate on rating plate is for installations at altitudes up to 2000 ft.

- In the U.S.A., the input ratings for altitudes above 2000 ft must be reduced by 2 percent for each 1000 ft above sea level.
- In Canada, the input ratings must be derated by 5 percent for altitudes of 2000 ft to 4500 ft above sea level.
- Furnace input rate must be within ± 2 percent of input on furnace rating plate adjusted for altitude.
 1. Determine natural gas orifice size and manifold pressure for correct input.
 - a. Obtain average yearly heat value (at installed altitude) from local gas supplier.
 - b. Obtain average yearly specific gravity from local gas supplier.
 - c. Verify furnace model and size. Table 8 can only be used for model 340MAV furnaces with heating sizes of 040 through 120. Table 9 can only be used for model 340MAV furnaces with a 140 heating size.
 - d. Find installation altitude in Table 8 or 9.
 - **NOTE:** For Canada altitudes of 2000 to 4500 ft, use U.S.A. altitudes of 2001 to 3000 ft in Table 8 or 9.
 - e. Find closest natural gas heat value and specific gravity in Table 8 or 9.
 - f. Follow heat value and specific gravity lines to point of intersection to find orifice size and manifold pressure settings for proper operation.

EXAMPLE: (0—2000 ft altitude using Table 8)
 Heating value = 1050 Btu/cu ft
 Specific gravity = 0.62
 Therefore: Orifice No. 45
 Manifold pressure 3.6-in. wc
 * Furnace is shipped with No. 45 orifices. In this example all main burner orifices are the correct size and do not need to be changed to obtain the proper input rate.

Check and verify burner orifice size in furnace. NEVER ASSUME ORIFICE SIZE; ALWAYS CHECK AND VERIFY.

2. Adjust manifold pressure to obtain input rate.

NOTE: Manifold pressure must always be measured with burner enclosure front REMOVED. Gas meter must always be clocked with burner enclosure front INSTALLED.

- a. Remove burner enclosure front.
- b. Remove cap that conceals adjustment screw for gas valve regulator. (See Fig. 44.)
- c. Turn adjusting screw, counterclockwise (out) to decrease manifold pressure or clockwise (in) to increase manifold pressure.

NOTE: This furnace has been approved for a manifold pressure of 3.2 in. wc to 3.8 in. wc when installed at altitudes up to 2000 ft. For altitudes above 2000 ft, the manifold pressure can be adjusted from 2.0 in. wc to 3.8 in. wc.

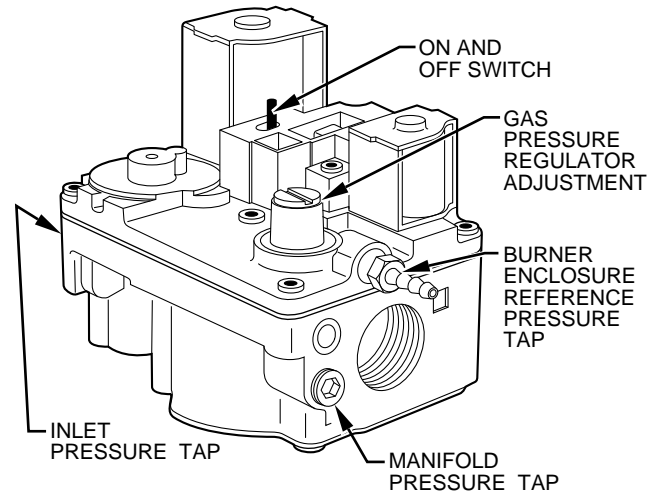
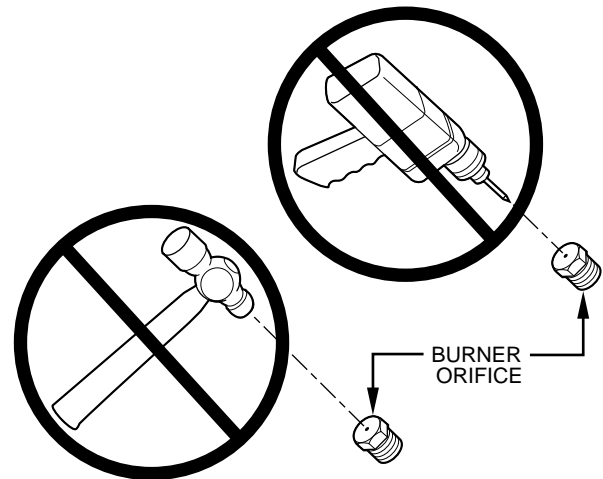

Fig. 44—Redundant Automatic Gas Valve

A95622

CAUTION: DO NOT bottom out gas valve regulator adjusting screw. This can result in unregulated manifold pressure and result in excess overfire and heat exchanger failures.

NOTE: If orifice hole appears damaged or it is suspected to have been redrilled, check orifice hole with a numbered drill bit of correct size. Never redrill an orifice. A burr-free and squarely aligned orifice hole is essential for proper flame characteristics.



A93059

CAUTION: DO NOT redrill orifices. Improper drilling (burrs, out-of-round holes, etc.) can cause excessive burner noise and misdirection of burner flames. This can result in flame impingement of burners and heat exchangers causing failures.

- d. Replace gas valve regulator adjustment screw cap.
- e. Replace burner enclosure front and verify adjusted gas input rate using method outlined in item 3.

→ TABLE 8—MODEL 340MAV ORIFICE SIZE AND MANIFOLD PRESSURE FOR CORRECT INPUT
FOR USE WITH 040 THROUGH 120 SIZE FURNACES ONLY
(TABULATED DATA BASED ON 20,000 BTUH PER BURNER, DERATED 2% FOR EACH 1000 FT ABOVE SEA LEVEL)

ALTITUDE RANGE (FT)		AVG GAS HEAT VALUE AT ALTITUDE (BTU/CU FT)	SPECIFIC GRAVITY OF NATURAL GAS									
			0.58		0.60		0.62		0.64		0.66	
			Orifice No.	Manifold Pressure	Orifice No.	Manifold Pressure	Orifice No.	Manifold Pressure	Orifice No.	Manifold Pressure	Orifice No.	Manifold Pressure
U.S.A. and Canada	0 to 2000	850	43	3.7	43	3.8	42	3.2	42	3.3	42	3.4
		875	43	3.5	43	3.6	43	3.7	43	3.8	42	3.2
		900	44	3.7	43	3.4	43	3.5	43	3.6	43	3.7
		925	44	3.5	44	3.7	44	3.8	43	3.4	43	3.5
		950	44	3.4	44	3.5	44	3.6	44	3.7	44	3.8
		975	44	3.2	44	3.3	44	3.4	44	3.5	44	3.6
		1000	45	3.7	45	3.8	44	3.2	44	3.4	44	3.5
		1025	45	3.5	45	3.6	45	3.7	44	3.2	44	3.3
		1050	45	3.3	45	3.4	45	3.6	45	3.7	45	3.8
		1075	45	3.2	45	3.3	45	3.4	45	3.5	45	3.6
	1100	47	3.6	47	3.7	45	3.2	45	3.4	45	3.5	
ALTITUDE RANGE (FT)		AVG GAS HEAT VALUE AT ALTITUDE (BTU/CU FT)	SPECIFIC GRAVITY OF NATURAL GAS									
			0.58		0.60		0.62		0.64		0.66	
			Orifice No.	Manifold Pressure	Orifice No.	Manifold Pressure	Orifice No.	Manifold Pressure	Orifice No.	Manifold Pressure	Orifice No.	Manifold Pressure
U.S.A. and Canada	U.S.A. Altitudes 2001 to 3000 or Canada Altitudes 2000 to 4500	775	43	3.8	42	3.2	42	3.3	42	3.4	42	3.5
		800	43	3.5	43	3.7	43	3.8	42	3.2	42	3.3
		825	44	3.8	43	3.4	43	3.6	43	3.7	43	3.8
		850	44	3.6	44	3.7	44	3.8	43	3.5	43	3.6
		875	44	3.4	44	3.5	44	3.6	44	3.7	43	3.4
		900	44	3.2	44	3.3	44	3.4	44	3.5	44	3.6
		925	45	3.7	45	3.8	44	3.2	44	3.3	44	3.4
		950	45	3.5	45	3.6	45	3.7	45	3.8	44	3.3
		975	45	3.3	45	3.4	45	3.5	45	3.6	45	3.8
		1000	45	3.1	45	3.2	45	3.4	45	3.5	45	3.6
	1025	45	3.0	45	3.1	45	3.2	45	3.3	45	3.4	
ALTITUDE RANGE (FT)		AVG GAS HEAT VALUE AT ALTITUDE (BTU/CU FT)	SPECIFIC GRAVITY OF NATURAL GAS									
			0.58		0.60		0.62		0.64		0.66	
			Orifice No.	Manifold Pressure	Orifice No.	Manifold Pressure	Orifice No.	Manifold Pressure	Orifice No.	Manifold Pressure	Orifice No.	Manifold Pressure
U.S.A. Only	3001 to 4000	750	43	3.7	43	3.8	42	3.3	42	3.4	42	3.5
		775	43	3.5	43	3.6	43	3.7	43	3.8	42	3.2
		800	44	3.7	43	3.4	43	3.5	43	3.6	43	3.7
		825	44	3.5	44	3.6	44	3.8	43	3.4	43	3.5
		850	44	3.3	44	3.4	44	3.5	44	3.7	44	3.8
		875	45	3.8	44	3.2	44	3.3	44	3.5	44	3.6
		900	45	3.6	45	3.7	45	3.8	44	3.3	44	3.4
		925	45	3.4	45	3.5	45	3.6	45	3.7	44	3.2
		950	45	3.2	45	3.3	45	3.4	45	3.5	45	3.7
		975	45	3.0	45	3.2	45	3.3	45	3.4	45	3.5
	1000	45	2.9	45	3.0	45	3.1	45	3.2	45	3.3	

→ TABLE 8—MODEL 340MAV ORIFICE SIZE AND MANIFOLD PRESSURE FOR CORRECT INPUT Continued
 FOR USE WITH 040 THROUGH 120 SIZE FURNACES ONLY
 (TABULATED DATA BASED ON 20,000 BTUH PER BURNER, DERATED 2% FOR EACH 1000 FT ABOVE SEA LEVEL)

ALTITUDE RANGE (FT)		AVG GAS HEAT VALUE AT ALTITUDE (BTU/CU FT)	SPECIFIC GRAVITY OF NATURAL GAS									
			0.58		0.60		0.62		0.64		0.66	
			Orifice No.	Manifold Pressure	Orifice No.	Manifold Pressure	Orifice No.	Manifold Pressure	Orifice No.	Manifold Pressure	Orifice No.	Manifold Pressure
U.S.A. Only	4001 to 5000	725	43	3.7	43	3.8	42	3.2	42	3.3	42	3.4
		750	43	3.4	43	3.5	43	3.7	43	3.8	42	3.2
		775	44	3.7	44	3.8	43	3.4	43	3.5	43	3.7
		800	44	3.5	44	3.6	44	3.7	44	3.8	43	3.4
		825	44	3.2	44	3.4	44	3.5	44	3.6	44	3.7
		850	45	3.7	45	3.8	44	3.3	44	3.4	44	3.5
		875	45	3.5	45	3.6	45	3.7	44	3.2	44	3.3
		900	45	3.3	45	3.4	45	3.5	45	3.6	45	3.8
		925	45	3.1	45	3.2	45	3.3	45	3.4	45	3.6
		950	45	3.0	45	3.1	45	3.2	45	3.3	45	3.4
U.S.A. Only	5001 to 6000	700	43	3.6	43	3.7	42	3.2	42	3.3	42	3.4
		725	43	3.4	43	3.5	43	3.6	43	3.7	43	3.8
		750	44	3.6	44	3.7	43	3.4	43	3.5	43	3.6
		775	44	3.4	44	3.5	44	3.6	44	3.7	43	3.4
		800	44	3.2	44	3.3	44	3.4	44	3.5	44	3.6
		825	45	3.6	45	3.7	44	3.2	44	3.3	44	3.4
		850	45	3.4	45	3.5	45	3.6	45	3.8	44	3.2
		875	45	3.2	45	3.3	45	3.4	45	3.6	45	3.7
		900	45	3.0	45	3.1	45	3.3	45	3.4	45	3.5
		925	45	2.9	45	3.0	45	3.1	45	3.2	45	3.3
		950	45	2.7	45	2.8	45	2.9	45	3.0	45	3.1
		975	45	2.6	45	2.7	45	2.8	45	2.9	45	2.9
		1000	45	2.5	45	2.5	45	2.6	45	2.7	45	2.8
U.S.A. Only	6001 to 7000	650	42	3.2	42	3.3	42	3.4	42	3.5	42	3.6
		675	43	3.6	43	3.7	43	3.8	42	3.2	42	3.3
		700	44	3.8	43	3.4	43	3.6	43	3.7	43	3.8
		725	44	3.6	44	3.7	44	3.8	43	3.4	43	3.5
		750	44	3.3	44	3.4	44	3.6	44	3.7	44	3.8
		775	45	3.8	44	3.2	44	3.3	44	3.4	44	3.5
		800	45	3.5	45	3.7	45	3.8	44	3.2	44	3.3
		825	45	3.3	45	3.4	45	3.6	45	3.7	45	3.8
		850	45	3.1	45	3.2	45	3.4	45	3.5	45	3.6
		875	45	3.0	45	3.1	45	3.2	45	3.3	45	3.4

→ TABLE 8—MODEL 340MAV ORIFICE SIZE AND MANIFOLD PRESSURE FOR CORRECT INPUT Continued
 FOR USE WITH 040 THROUGH 120 SIZE FURNACES ONLY
 (TABULATED DATA BASED ON 20,000 BTUH PER BURNER, DERATED 2% FOR EACH 1000 FT ABOVE SEA LEVEL)

ALTITUDE RANGE (FT)		AVG GAS HEAT VALUE AT ALTITUDE (BTU/CU FT)	SPECIFIC GRAVITY OF NATURAL GAS									
			0.58		0.60		0.62		0.64		0.66	
			Orifice No.	Manifold Pressure	Orifice No.	Manifold Pressure	Orifice No.	Manifold Pressure	Orifice No.	Manifold Pressure	Orifice No.	Manifold Pressure
U.S.A. Only	7001 to 8000	625	43	3.8	42	3.3	42	3.4	42	3.5	42	3.6
		650	43	3.5	43	3.7	43	3.8	42	3.2	42	3.3
		675	44	3.8	43	3.4	43	3.5	43	3.6	43	3.7
		700	44	3.5	44	3.6	44	3.8	43	3.4	43	3.5
		725	44	3.3	44	3.4	44	3.5	44	3.6	44	3.7
		750	45	3.7	45	3.8	44	3.3	44	3.4	44	3.5
		775	45	3.5	45	3.6	45	3.7	45	3.8	44	3.3
		800	45	3.3	45	3.4	45	3.5	45	3.6	45	3.7
		825	45	3.1	45	3.2	45	3.3	45	3.4	45	3.5
		850	45	2.9	45	3.0	45	3.1	45	3.2	45	3.3
U.S.A. Only	8001 to 9000	600	43	3.8	42	3.3	42	3.4	42	3.5	42	3.6
		625	43	3.5	43	3.6	43	3.8	42	3.2	42	3.3
		650	44	3.7	43	3.4	43	3.5	43	3.6	43	3.7
		675	44	3.5	44	3.6	44	3.7	44	3.8	43	3.4
		700	44	3.2	44	3.3	44	3.4	44	3.6	44	3.7
		725	45	3.6	45	3.8	44	3.2	44	3.3	44	3.4
		750	45	3.4	45	3.5	45	3.6	45	3.8	44	3.2
		775	45	3.2	45	3.3	45	3.4	45	3.5	45	3.6
		800	45	3.0	45	3.1	45	3.2	45	3.3	45	3.4
		U.S.A. Only	9001 to 10,000	575	43	3.8	42	3.2	42	3.3	42	3.5
600	43			3.5	43	3.6	43	3.7	42	3.2	42	3.3
625	44			3.7	44	3.8	43	3.5	43	3.6	43	3.7
650	44			3.4	44	3.5	44	3.7	44	3.8	43	3.4
675	45			3.8	44	3.3	44	3.4	44	3.5	44	3.6
700	45			3.6	45	3.7	45	3.8	44	3.3	44	3.4
725	45			3.3	45	3.4	45	3.6	45	3.7	45	3.8
750	45			3.1	45	3.2	45	3.3	45	3.4	45	3.5
775	45			2.9	45	3.0	45	3.1	45	3.2	45	3.3

→ TABLE 9—MODEL 340MAV ORIFICE SIZE AND MANIFOLD PRESSURE FOR CORRECT INPUT
FOR USE WITH 140 SIZE FURNACES ONLY

(TABULATED DATA BASED ON 23,000 BTUH PER BURNER, DERATED 2% FOR EACH 1000 FT ABOVE SEA LEVEL)

ALTITUDE RANGE (FT)		AVG GAS HEAT VALUE AT ALTITUDE (BTU/CU FT)	SPECIFIC GRAVITY OF NATURAL GAS									
			0.58		0.60		0.62		0.64		0.66	
			Orifice No.	Manifold Pressure	Orifice No.	Manifold Pressure	Orifice No.	Manifold Pressure	Orifice No.	Manifold Pressure	Orifice No.	Manifold Pressure
U.S.A. and Canada	0 to 2000	850	41	3.6	41	3.7	41	3.8	40	3.6	40	3.8
		875	42	3.8	41	3.5	41	3.6	41	3.7	41	3.8
		900	42	3.5	42	3.7	42	3.8	41	3.5	41	3.6
		925	42	3.4	42	3.5	42	3.6	42	3.7	42	3.8
		950	42	3.2	42	3.3	42	3.4	42	3.5	42	3.6
		975	43	3.7	43	3.8	42	3.2	42	3.3	42	3.4
		1000	43	3.5	43	3.6	43	3.7	42	3.2	42	3.3
		1025	43	3.3	43	3.4	43	3.6	43	3.7	43	3.8
		1050	43	3.2	43	3.3	43	3.4	43	3.5	43	3.6
		1075	44	3.5	44	3.6	43	3.2	43	3.3	43	3.4
1100	44	3.3	44	3.4	44	3.5	43	3.2	43	3.3		
ALTITUDE RANGE (FT)		AVG GAS HEAT VALUE AT ALTITUDE (BTU/CU FT)	SPECIFIC GRAVITY OF NATURAL GAS									
			0.58		0.60		0.62		0.64		0.66	
			Orifice No.	Manifold Pressure	Orifice No.	Manifold Pressure	Orifice No.	Manifold Pressure	Orifice No.	Manifold Pressure	Orifice No.	Manifold Pressure
U.S.A. and Canada	U.S.A. Altitudes 2001 to 3000 or Canada Altitudes 2001 to 4500	775	41	3.7	41	3.8	40	3.6	40	3.7	39	3.6
		800	42	3.8	41	3.6	41	3.7	41	3.8	40	3.6
		825	42	3.6	42	3.7	41	3.5	41	3.6	41	3.7
		850	42	3.4	42	3.5	42	3.6	42	3.7	41	3.5
		875	42	3.2	42	3.3	42	3.4	42	3.5	42	3.6
		900	43	3.7	43	3.8	42	3.2	42	3.3	42	3.4
		925	43	3.5	43	3.6	43	3.7	42	3.2	42	3.3
		950	43	3.3	43	3.4	43	3.5	43	3.7	43	3.8
		975	43	3.1	43	3.3	43	3.4	43	3.5	43	3.6
		1000	43	3.0	43	3.1	43	3.2	43	3.3	43	3.4
1025	43	2.8	43	2.9	43	3.0	43	3.1	43	3.2		
ALTITUDE RANGE (FT)		AVG GAS HEAT VALUE AT ALTITUDE (BTU/CU FT)	SPECIFIC GRAVITY OF NATURAL GAS									
			0.58		0.60		0.62		0.64		0.66	
			Orifice No.	Manifold Pressure	Orifice No.	Manifold Pressure	Orifice No.	Manifold Pressure	Orifice No.	Manifold Pressure	Orifice No.	Manifold Pressure
U.S.A. Only	3001 to 4000	750	41	3.6	41	3.8	40	3.6	40	3.7	40	3.8
		775	42	3.8	41	3.5	41	3.6	41	3.7	40	3.6
		800	42	3.5	42	3.7	42	3.8	41	3.5	41	3.6
		825	42	3.3	42	3.4	42	3.6	42	3.7	42	3.8
		850	43	3.8	42	3.2	42	3.4	42	3.5	42	3.6
		875	43	3.6	43	3.7	42	3.2	42	3.3	42	3.4
		900	43	3.4	43	3.5	43	3.6	43	3.8	42	3.2
		925	43	3.2	43	3.3	43	3.5	43	3.6	43	3.7
		950	43	3.1	43	3.2	43	3.3	43	3.4	43	3.5
		975	43	2.9	43	3.0	43	3.1	43	3.2	43	3.3
1000	43	2.8	43	2.9	43	3.0	43	3.0	43	3.1		

→ TABLE 9—MODEL 340MAV ORIFICE SIZE AND MANIFOLD PRESSURE FOR CORRECT INPUT Continued
 FOR USE WITH 140 SIZE FURNACES ONLY
 (TABULATED DATA BASED ON 23,000 BTUH PER BURNER, DERATED 2% FOR EACH 1000 FT ABOVE SEA LEVEL)

ALTITUDE RANGE (FT)		AVG GAS HEAT VALUE AT ALTITUDE (BTU/CU FT)	SPECIFIC GRAVITY OF NATURAL GAS									
			0.58		0.60		0.62		0.64		0.66	
			Orifice No.	Manifold Pressure	Orifice No.	Manifold Pressure	Orifice No.	Manifold Pressure	Orifice No.	Manifold Pressure	Orifice No.	Manifold Pressure
U.S.A. Only	4001 to 5000	725	41	3.6	41	3.7	41	3.8	40	3.6	40	3.8
		750	42	3.7	42	3.8	41	3.6	41	3.7	41	3.8
		775	42	3.5	42	3.6	42	3.7	42	3.8	41	3.6
		800	42	3.3	42	3.4	42	3.5	42	3.6	42	3.7
		825	43	3.7	42	3.2	42	3.3	42	3.4	42	3.5
		850	43	3.5	43	3.6	43	3.8	42	3.2	42	3.3
		875	43	3.3	43	3.4	43	3.6	43	3.7	43	3.8
		900	43	3.1	43	3.3	43	3.4	43	3.5	43	3.6
		925	43	3.0	43	3.1	43	3.2	43	3.3	43	3.4
		950	43	2.8	43	2.9	43	3.0	43	3.1	43	3.2
U.S.A. Only	5001 to 6000	700	41	3.5	41	3.7	41	3.8	40	3.6	40	3.7
		725	42	3.7	42	3.8	41	3.5	41	3.6	41	3.8
		750	42	3.4	42	3.5	42	3.7	42	3.8	41	3.5
		775	42	3.2	42	3.3	42	3.4	42	3.5	42	3.7
		800	43	3.7	43	3.8	42	3.2	42	3.3	42	3.4
		825	43	3.5	43	3.6	43	3.7	43	3.8	42	3.2
		850	43	3.3	43	3.4	43	3.5	43	3.6	43	3.7
		875	43	3.1	43	3.2	43	3.3	43	3.4	43	3.5
		900	43	2.9	43	3.0	43	3.1	43	3.2	43	3.3
		925	43	2.7	43	2.8	43	2.9	43	3.0	43	3.1
		950	43	2.6	43	2.7	43	2.8	43	2.9	43	3.0
		975	43	2.5	43	2.6	43	2.6	43	2.7	43	2.8
		1000	43	2.3	43	2.4	43	2.5	43	2.6	43	2.7
U.S.A. Only	6001 to 7000	650	41	3.8	40	3.6	40	3.7	40	3.8	39	3.7
		675	41	3.5	41	3.6	41	3.7	40	3.6	40	3.7
		700	42	3.6	42	3.7	41	3.5	41	3.6	41	3.7
		725	42	3.4	42	3.5	42	3.6	42	3.7	42	3.8
		750	43	3.8	42	3.3	42	3.4	42	3.5	42	3.6
		775	43	3.6	43	3.7	43	3.8	42	3.3	42	3.4
		800	43	3.4	43	3.5	43	3.6	43	3.7	43	3.8
		825	43	3.2	43	3.3	43	3.4	43	3.5	43	3.6
		850	43	3.0	43	3.1	43	3.2	43	3.3	43	3.4
		875	43	2.8	43	2.9	43	3.0	43	3.1	43	3.2

- f. Look through sight glass in burner enclosure and check burner flame. Burner flame should be clear blue, almost transparent. (See Fig. 45.)

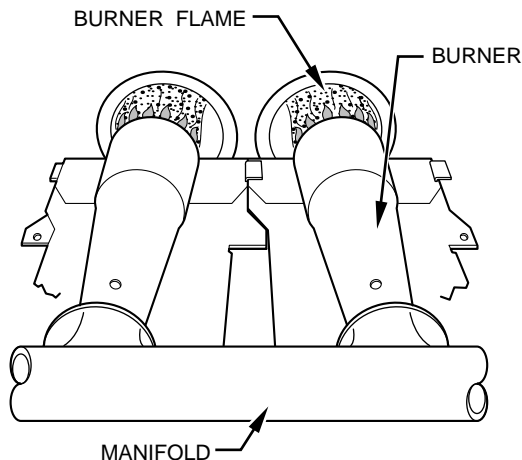

A89020

Fig. 45—Burner Flame

3. Verify natural gas input rate by clocking gas meter.

NOTE: Be sure all pressure tubing, combustion-air and vent pipes, and burner enclosure front are in place when checking input by clocking gas meter.

- a. Calculate high-altitude adjustment (if required).

UNITED STATES

At altitudes above 2000 ft, this furnace has been approved for a 2% derate for each 1000 ft above sea level. See Table 10 for derate multiplier factor.

TABLE 10—ALTITUDE DERATE MULTIPLIER FOR U.S.A.

ALTITUDE (FT)	% OF DERATE	DERATE MULTIPLIER FACTOR FOR U.S.A.*
0—2000	0	1.00
2001—3000	4—6	0.95
3001—4000	6—8	0.93
4001—5000	8—10	0.91
5001—6000	10—12	0.89
6001—7000	12—14	0.87
7001—8000	14—16	0.85
8001—9000	16—18	0.83
9001—10,000	18—20	0.81

* Derate multiplier factor is based on midpoint altitude for altitude range.

EXAMPLE:

100,000 Btuh input furnace installed at 4300 ft.

Furnace Input Rate at Sea Level	X	Derate Multiplier Factor	=	Furnace Input Rate at Installation Altitude
100,000	X	0.91	=	91,000

CANADA

→ At installation altitudes from 2000 to 4500 ft, this furnace must be derated 5% by an authorized Gas Conversion Station or Dealer. To determine correct input rate for altitude, see example above and use 0.95 as derate multiplier factor.

- b. Turn off all other gas appliances and pilots.
 c. Start furnace and let operate for 3 minutes.
 d. Measure time (in sec) for gas meter test dial to complete 1 revolution.

- e. Refer to Table 11 for cu ft of gas per hr.

TABLE 11—GAS RATE (CU FT/HR)

SECONDS FOR 1 REVOLUTION	SIZE OF TEST DIAL			SECONDS FOR 1 REVOLUTION	SIZE OF TEST DIAL		
	1 cu ft	2 cu ft	5 cu ft		1 cu ft	2 cu ft	5 cu ft
10	360	720	1800	50	72	144	360
11	327	655	1636	51	71	141	355
12	300	600	1500	52	69	138	346
13	277	555	1385	53	68	136	340
14	257	514	1286	54	67	133	333
15	240	480	1200	55	65	131	327
16	225	450	1125	56	64	129	321
17	212	424	1059	57	63	126	316
18	200	400	1000	58	62	124	310
19	189	379	947	59	61	122	305
20	180	360	900	60	60	120	300
21	171	343	857	62	58	116	290
22	164	327	818	64	56	112	281
23	157	313	783	66	54	109	273
24	150	300	750	68	53	106	265
25	144	288	720	70	51	103	257
26	138	277	692	72	50	100	250
27	133	267	667	74	48	97	243
28	129	257	643	76	47	95	237
29	124	248	621	78	46	92	231
30	120	240	600	80	45	90	225
31	116	232	581	82	44	88	220
32	113	225	563	84	43	86	214
33	109	218	545	86	42	84	209
34	106	212	529	88	41	82	205
35	103	206	514	90	40	80	200
36	100	200	500	92	39	78	196
37	97	195	486	94	38	76	192
38	95	189	474	96	38	75	188
39	92	185	462	98	37	74	184
40	90	180	450	100	36	72	180
41	88	176	439	102	35	71	178
42	86	172	429	104	35	69	173
43	84	167	419	106	34	68	170
44	82	164	409	108	33	67	167
45	80	160	400	110	33	65	164
46	78	157	391	112	32	64	161
47	76	153	383	116	31	62	155
48	75	150	375	120	30	60	150
49	73	147	367				

- f. Multiply gas rate (cu ft/hr) X heating value (Btu/cu ft) using natural gas heating value from local gas utility/supplier.

EXAMPLE: (0—2000 ft altitude)

Furnace input from rating plate is 100,000 Btuh.

Btu heating input = Btu/cu ft X cu ft/hr

Heating value of gas = 975 Btu/cu ft

Time for 1 revolution of 2-cu ft dial = 70 sec

Gas rate = 103 cu ft/hr (from Table 11)

Btu heating input = 103 X 975 = 100,425 Btuh

In this example, the orifice size and manifold pressure adjustment is within ±2 percent of the furnace input rate.

B. Set Temperature Rise

CAUTION: Temperature rise must be within limits specified on unit rating plate. Recommended operation is at midpoint of rise or above. Failure to follow this caution may result in condensing or overheating the heat exchangers.

Determine and adjust air temperature rise as follows:

1. Place thermometers in return and supply ducts as close to furnace as possible. Be sure thermometers do not see heat exchanger so that radiant heat does not affect readings. This practice is particularly important with straight-run ducts.
2. When thermometer readings stabilize, subtract return-air temperature from supply-air temperature to determine air temperature rise.

- Adjust temperature rise by adjusting blower speed. Increase blower speed to reduce temperature rise. Decrease blower speed to increase temperature rise.

WARNING: Disconnect 115-v electrical power before changing speed tap. Failure to follow this warning could result in personal injury.

- To change blower motor speed selections for heating mode, remove blower motor lead from control center HEAT terminal. (See Fig. 25.) Select desired blower motor speed lead from 1 of the other terminals and relocate it to HEAT terminal. See Table 12 for lead color identification. Reconnect original lead on SPARE terminal.

Follow this same procedure for proper selection of COOL speed selection.

TABLE 12—SPEED SELECTOR

COLOR	SPEED	FACTORY-SHIPPED CONNECTION
Black	High	Cool
Yellow (When Present)	Medium High	Spare
Blue	Medium Low	Heat
Red	Low	Spare
White	Common	Com

C. Blower Off Delay (Heat Mode)

The main blower off time delay period is factory-set at 135 sec and is not field-adjustable.

D. Set Thermostat Heat Anticipator

Thermostat heat anticipator must be set to match amp draw of components in R-W circuit. Accurate amp draw measurements can be obtained at thermostat subbase terminals R and W.

Fig. 46 illustrates an easy method of obtaining these measurements. Amp reading should be taken after blower motor has started. See thermostat manufacturer's instructions for adjusting heat anticipator and for varying heating cycle length.

CHECK SAFETY CONTROLS

I. CHECK PRIMARY LIMIT CONTROL

This control shuts off combustion control system and energizes air-circulating blower motor if furnace overheats. Recommended method of checking this limit control is to gradually block off return air after furnace has been operating for a period of at least 5 minutes. As soon as limit control has shut off burners, return-air opening should be unblocked to permit normal air circulation. By using this method to check limit control, it can be established that limit is functioning properly and operates if there is a restricted return-air supply or motor failure. If limit control does not function during this test, cause must be determined and corrected.

II. CHECK PRESSURE SWITCH

This control proves operation of draft inducer. Check switch operation as follows:

- Turn off 115-v power to furnace.

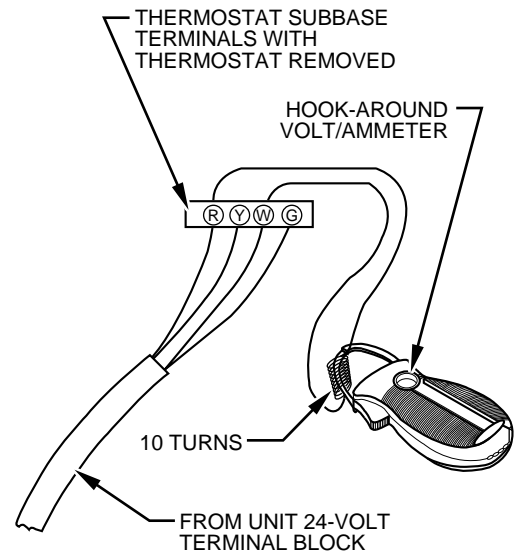

EXAMPLE: $\frac{5.0 \text{ AMPS ON AMMETER}}{10 \text{ TURNS AROUND JAWS}} = 0.5 \text{ AMPS FOR THERMOSTAT SETTING}$

A80201

Fig. 46—Amp Draw Check with Ammeter

- Remove main furnace door and disconnect inducer motor lead wires from wire harness.
- Turn on 115-v power to furnace.
- Set thermostat to call for heat and wait 1 minute. When pressure switch is functioning properly, hot surface ignitor should NOT glow, and control center diagnostic light flashes a Status Code 31. If hot surface ignitor glows when inducer motor is disconnected, shut furnace down immediately. Determine reason pressure switch did not function properly and correct condition.
- Turn off 115-v power to furnace.
- Reconnect inducer motor leads, reinstall main furnace door, and turn on 115-v power supply.

CHECKLIST

- Put away tools and instruments. Clean up debris.
- Verify manual reset switch has continuity.
- Verify that blower and control access doors are properly installed.
- Cycle test furnace with room thermostat.
- Check operation of accessories per manufacturer's instructions.
- Review User's Guide with owner.
- Leave literature packet near furnace.

CHECKLIST—INSTALLATION

LOAD CALCULATION

_____ Heating Load (Btuh)
_____ Cooling Load (Btuh)
_____ Furnace Model Selection

COMBUSTION AND VENT PIPING

Termination Location

_____ Roof or Sidewall
_____ Termination Kit — 2 Pipe or Concentric
_____ Combustion-Air Pipe Length
_____ Combustion-Air Pipe Elbow Quantity
_____ Vent Pipe Length
_____ Vent Pipe Elbow Quantity
_____ Pipe Diameter Determined from Sizing Table
_____ Pipe Sloped To Furnace

Pipe Insulation

_____ Over Ceilings
_____ Low-Ambient Exposed Pipes

Condensate Drain

_____ Unit Level or Pitched Forward
_____ Internal Tubing Connections Free of Kinks and Traps
_____ External Drain Connection Leak Tight and Sloped
_____ Condensate Trap Primed before Start-Up
_____ Heat Tape Installed if Required

CHECKLIST—START-UP

_____ Gas Input Rate
(Set Within 2 percent of Rating Plate)
_____ Temperature Rise Adjusted
_____ Thermostat Anticipator
_____ Anticipator Setting Adjusted or
_____ Cycle Rate (3 Cycles per Hr) Selected

Safety Controls Check Operation

_____ Primary Limit
_____ Pressure Switch

SERVICE TRAINING

Packaged Service Training programs are an excellent way to increase your knowledge of the equipment discussed in this manual, including:

- Unit Familiarization
- Maintenance
- Installation Overview
- Operating Sequence

A large selection of product, theory, and skills programs is available, using popular video-based formats and materials. All include video and/or slides, plus companion book.

Classroom Service Training plus "hands-on" the products in our labs can mean increased confidence that really pays dividends in faster troubleshooting, fewer callbacks. Course descriptions and schedules are in our catalog.

CALL FOR FREE CATALOG 1-800-962-9212

Packaged Service Training

Classroom Service Training

A94328